

(19)



(11)

**EP 2 322 752 A1**

(12)

**EUROPEAN PATENT APPLICATION**  
published in accordance with Art. 153(4) EPC

(43) Date of publication:

**18.05.2011 Bulletin 2011/20**

(51) Int Cl.:

**E06C 1/12 (2006.01)**

**E06C 7/06 (2006.01)**

(21) Application number: **09806287.0**

(86) International application number:

**PCT/CN2009/000792**

(22) Date of filing: **14.07.2009**

(87) International publication number:

**WO 2010/017684 (18.02.2010 Gazette 2010/07)**

(84) Designated Contracting States:

**AT BE BG CH CY CZ DE DK EE ES FI FR GB GR  
HR HU IE IS IT LI LT LU LV MC MK MT NL NO PL  
PT RO SE SI SK SM TR**

Designated Extension States:

**AL BA RS**

(72) Inventor: **WANG, Wanxing**

**Ninghai County  
Zhejiang 315600 (CN)**

(74) Representative: **Hall, Graeme Keith**

**Marks & Clerk LLP  
5th Floor  
14 South Parade  
Leeds LS1 5QS (GB)**

(30) Priority: **14.08.2008 CN 200820162785 U**

(71) Applicant: **Ningbo Xingfu Tools Co., Ltd.  
Zhejiang 315600 (CN)**

(54) **EXTENDING LADDER**

(57) The extending ladder comprises a left stile (1), right stile (2) which disposed oppositely and a plurality of rungs (3) which extends between the left (1) stile and the right stile (2), the left stile (1) and right stile (2) are respectively formed of telescopically collapsible left columns (11) and right columns (12) which are disposed orderly in a nested arrangement for relative lengthwise movement in a telescopic fashion, a left latch mechanism (4) and right latch (5) are disposed in each rung (3). A left button (6) and a right button (7) are disposed closely with each other in the middle of the corresponding rung (3), so as to make two buttons be operated conveniently by single hand to make the rung (3) released from the corresponding column.

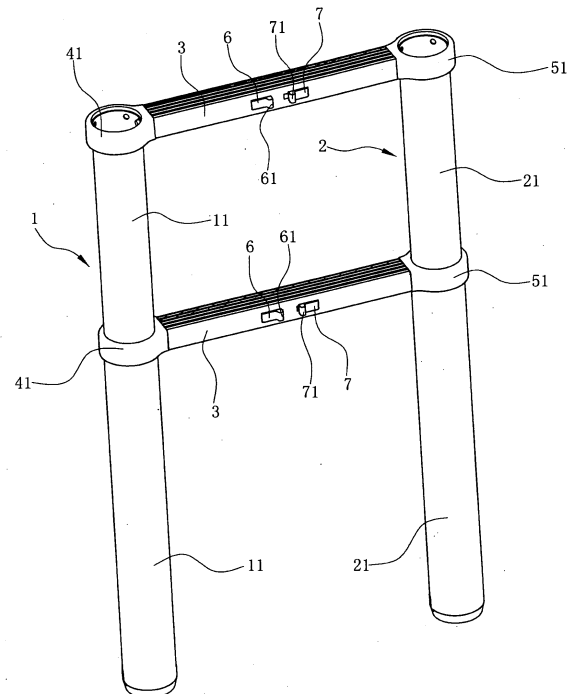

Fig. 1

**EP 2 322 752 A1**

## Description

### Field of the Invention

**[0001]** The present invention relates to a ladder, in particular to an extending ladder including a plurality of stiles disposed in a nested arrangement and being able to slip relatively.

### Description of the Prior Art

**[0002]** The ladder should usually be used, when the residences, apartments, farms, factories or other places are being repaired or maintained. While the ladder should be stored up when it is not be used. A longer ladder can reach a higher height but it is not convenient to be transported and it will take up more space when the ladder should be stored up. While, an extending ladder can be extended when being used and can be collapsed when being stored up.

**[0003]** European Patent EP0527766B1 discloses an extending ladder with a similar structure, which comprises:

two stiles formed of telescopically collapsible sections, the lower end of each section is fitted within the next lower section;  
a plurality of rungs each mounted between two sections of the respective stiles;  
and latch mechanisms located in the rungs for automatically locking the sections of the stiles relative to on another when the sections are extended;  
characterized in that the latch mechanisms in each rung are arranged to release the sections of the stiles connected to the next higher rung when the rung is collapsed against the next lower rung.

**[0004]** The patent provides a ladder having the function of automatic collapsed from bottom to top. Once the two rungs at the utmost bottom are collapsed, the third rung ranking from bottom to top will be collapsed automatically, and so on until the rung at the top is collapsed automatically in the same manner. However, in the meanwhile, such function will result in the unsafe usage and seem to cause accidents, especially to the damage caused by the pressure of the rung. During the usage of the ladder, if a third party unintentionally touches the switch of the most bottom rung, all of the rungs will then collapse automatically, thus it is highly possible to make the user who stands on the rung to fall down and be harmed.

**[0005]** Therefore, an existing extending ladder will be safe all the better when being used, which will be completely collapsed only if the button on each rung is pressed one rung at a time.

**[0006]** US Patent US7048094B2 also discloses a convenient and safe extending ladder, which comprises:

A first stile, a second stile and a plurality of rungs extending between the first stile and the second stile;  
The first stile comprising a first column and a second column disposed in a nested arrangement for relative lengthwise movement in a telescopic fashion;  
A latch mechanism for selectively locking the second column relative the first column;  
A button operatively coupled to the latch mechanism for actuating the latch mechanism; the button is positioned and dimensioned to contact a tip portion of a thumb of a hand while the first column is grasped between a palm of the hand and at least one finger of the hand;  
A sleeve disposed about an exterior surface of the second column; the sleeve includes an external guiding surface for contacting the internal surface of the first column.

**[0007]** Compared with the existing much safer extending ladder, in the claim of this US patent, the most prominent characters are the 'button' and the 'sleeve', and the main object is to make the button control more convenient and reduce the degree of the friction and the abrasion between two adjacent columns.

**[0008]** According to the common sense, it is generally believed that it will be more convenient for the user to operate the latch mechanism so as to retract the characteristics if the button is arranged nearby the column. However, each rung is equipped with two buttons arranged respectively at both ends of the rung. So that, when the user operates the latch mechanism, his two hands should hold the first stile and the second stile and his two thumbs should simultaneously respectively touch the two buttons on each rung, in other words, a pair of hands must be used to operate the two buttons simultaneously and successfully. The practical application shows that such operating manner is still inconvenient.

**[0009]** In conclusion, the existing extending ladder needs to be further improved.

### Summary of the Invention

**[0010]** It is the first object of the present invention to provide an extending ladder in which the button can be operated by only one hand to unlock the rung with the corresponding column, so as to make the collapse operation of the ladder more convenient.

**[0011]** The second object of the present invention is to provide an extending ladder, which can prevent the upper column from breaking away from the next lower column when the columns are pulled up quickly, and can remind the user whether the columns are pulled in right position.

**[0012]** For achieving above stated first object, the extending ladder comprising:

a left stile and a right stile which disposed oppositely;  
a plurality of rungs extending between the left stile

and the right stile;  
 the left stile formed of telescopically collapsible left columns which are disposed orderly in a nested arrangement;  
 the right stile formed of telescopically collapsible right columns which are disposed orderly in a nested arrangement;  
 and each rung mounted between the opposite two columns;  
 a left latch mechanism disposed in each rung for locking the upper left column with the corresponding rung when the ladder extending lengthwise, to prevent the ladder from collapsing;  
 a right latch mechanism disposed in each rung for locking the upper right column with the corresponding rung when the ladder extending lengthwise, to keep the ladder from collapsing;  
 the left latch mechanism and right latch mechanism respectively provided with a left button and a right button to operate the corresponding latch mechanism;  
 characterized in that the left button and the right button disposed closely with each other in the middle of each rung, so as to make two buttons be operated conveniently by single hand to make the rung released from the corresponding column.

**[0013]** As a preference, the left latch mechanism can also comprises:

a left connector coupled to the left end of each rung, which makes the rung be connected with the upper part of the corresponding left column;  
 a left pin disposed in each rung, which can move horizontally and transversely relatively to the corresponding rung and can stick out of the left side of the corresponding rung;  
 and a first spring disposed out of the left pin to ensure the left pin have a trend of sticking out of the left side of the rung;  
 the left button is connected with the left pin, correspondingly, a first locking holes is provided on the top of the left column for the corresponding left pin to pass through, and a second locking holes is provided on the middle of the left column for the corresponding left pin to insert into the left column;  
 while the right latch mechanism also comprises:

a right connector coupled to the right end of each rung, which makes the rung be connected with the upper part of the corresponding right column;  
 a right pin disposed in each rung, which can move horizontally and transversely relatively to the corresponding rung and can stick out of the right side of the corresponding rung;  
 and a second spring disposed out of the right pin to ensure the right pin have a trend of sticking out of the right side of the rung;

the right button is connected with the right pin, correspondingly, a third locking holes is provided on the top of the right column for the corresponding right pin to pass through, and a fourth locking holes is provided on the middle of the right column for the corresponding right pin to insert into the right column.

**[0014]** The above stated latch mechanism is provided with fewer component, so such latch mechanism is in simple structure. Of course, the left and right latch mechanism can also be applied with various latch manners used in the existing extending ladders.

**[0015]** Preferably, a first spring seat can be provided on the left side of the interior of the rung, which the left pin can movably pass through, the first spring is disposed in the first spring seat with one end against the inner wall of the right side of the first spring seat and the other end against a shoulder protruded at the middle of the left pin;  
 a second spring seat can be provided on the right side of the interior of the rung, which the right pin can movably pass through, the second spring is disposed in the second spring seat with one end against the inner wall of the left side of the second spring seat and the other end against a shoulder protruded at the middle of the right pin.

**[0016]** Said spring seats not only can contain the corresponding spring, but also can sustain the corresponding pin.

**[0017]** As a preference, a left limiting block can be provided on the left side of the interior of the rung, which the left pin can movably pass through, and two stop rings are provided on the left pin in distance, which respectively locates at two sides of the left limiting block and can respectively be stopped by the surface of two sides of the left limiting block;

**[0018]** While a right limiting block can be provided on the right side of the interior of the rung, which the right pin can movably pass through, and two stop rings are provided on the right pin in distance, which respectively locates at two sides of the right limiting block and can respectively be stopped by the surface of two sides of the right limiting block.

**[0019]** Said limiting block can limit the movement of the corresponding pin, so the left and right button can be well controlled to move within a proper scope. Of course, the structure of the limiting the movement of the pin is not limited in the above stated structure, other prior technique can also be adopted.

**[0020]** For achieving above stated second object, the extending ladder can be improved as below:

a left limiting annulation is mounted around of the periphery surface of the middle of the left column, which is sandwiched between two adjacent left columns, correspondingly, the left connector is provided with an annular wall to form a socket which is preferably dimensioned to tightly connect with the periphery of the top of the left column, an inner should-

der protruding inward is formed on the top of the inner wall of the socket to stop the left limiting annulation, and the left connector is also provided with a through hole communicating with the socket for the left pin to pass through;

while a right limiting annulation is mounted around the periphery surface of the middle of the right column, which is sandwiched between two adjacent right columns, correspondingly, the right connector is provided with an annular wall to form a socket which is preferably dimensioned to tightly connect with the periphery of the top of the right column, an inner shoulder protruding inward is formed on the top of the inner wall of the socket to stop the right limiting annulation, and the right connector is also provided with a through hole communicating with the socket for the right pin to pass through.

**[0021]** After the column is pulled upward to be in position, the corresponding limiting annulation will be stopped by the matched inner shoulder on the corresponding connector, then the column will be prevented from being pulling out further. Moreover, when the limiting annulation is stopped by the corresponding inner shoulder, that is the column can not be pulled upward easily, it will indicate that the column has been in right position and the user should stop pulling.

**[0022]** As a preference, the limiting annulation limited on the corresponding column can adopt the manner as below:

the left limiting annulation is provided with a first gap opposite to the first locking hole, and the inner wall of the left limiting annulation is provided with a plurality of protrusions, correspondingly, the peripheral of the middle of the left column is provided with a plurality of small holes for the corresponding protrusion to insert;

while the right limiting annulation is provided with a second gap opposite to the third locking hole, and the inner wall of the right limiting annulation is provided with a plurality of protrusions, correspondingly, the peripheral of the middle of the right column is provided with a plurality of small holes for the corresponding protrusion to insert.

**[0023]** Said limiting annulation can be limited at the middle of the column conveniently and stably. When assembling, opening the limiting annulation along the direction of the gap, placing the limiting annulation out of peripheral surface of the column, and making each protrusion enter into corresponding small hole, then the limiting annulation is completely installed.

**[0024]** As a preference, a left bushing is mounted around the opening of the bottom of the left column, the exterior surface of the upper part of the left bushing is in contact with the inner wall of the next lower left column, and the exterior surface of the lower part of the left bush-

ing is tapered;

While a right bushing is mounted around the opening of the bottom of the right column, the exterior surface of the upper part of the right bushing is in contact with the inner wall of the next lower right column, and the exterior surface of the lower part of the right bushing is tapered.

**[0025]** In the above stated structure, as the exterior surface of the upper part of the left or right bushing is respectively in contact with the inner wall of the next lower left or right column, adjacent columns can be damped when moves relatively and can be kept from moving relatively too fast, to avoid the damage of the rungs caused by the mutual clash between the adjacent rungs and reduce the noise caused by the mutual clash of the rungs. In addition, the exterior surface of the lower part of the bushing is tapered, it is helpful for the user to insert the upper column into the next lower column when assembling.

**[0026]** As a preference, the internal surface of the upper part of the left bushing is provided with a plurality of projects, correspondingly, the peripheral of the bottom of the left column is provided with a plurality of location holes for the corresponding project to insert;

While the internal surface of the upper part of the right bushing is provided with a plurality of projects, correspondingly, the peripheral of the bottom of the right column is provided with a plurality of location holes for the corresponding project to insert.

**[0027]** With the coordination of the projects and location holes, the bushing can be mounted on the bottom of the column. It makes the assembling much easy.

**[0028]** In order to operate the button with the fingers conveniently, the right side of the left button can be provided with a resisting portion which is convenient for the fingertip to resist against, and the left side of the right button can also be provided with a resisting portion which is convenient for the fingertip to resist against. It can reduce the operating span of the fingers, it is helpful for the fingers to exert on the buttons when operating and it makes the operating more easily for the user.

**[0029]** Compared with the prior art, in this present invention, the left and right buttons are adjacently arranged on the middle of each rung, so that two buttons can be operated with one hand simultaneously to unlock the rung relative to the corresponding left and right column. When operating the buttons, only the thumb and the index figure of the same hand have to be opened, the thumb touches the right button and the index figure touches the left button, then, two fingers drives the left and right buttons respectively to move closely and closely with inward force at the same time, to operate left and right latch mechanism and unlock the rung. Therefore, the operation is very convenient for the user. While the other hand can hold the columns and make the columns move downward. Accordingly, the clash between the adjacent rungs can be avoided and a stable operation process can be also ensured.

## Brief Description of the Drawings

### [0030]

FIG.1 is a perspective view of the extending ladder in accordance with an exemplary embodiment of the present invention.

FIG.2 is the sectional view of the extending ladder of FIG.1.

FIG.3 is an enlarged view of region A in the FIG.2.

FIG.4 is an enlarged view of region B in the FIG.2.

FIG.5 is an enlarged view of region C in the FIG.2.

FIG.6 is an enlarged view of region D in the FIG.2.

FIG.7 is an enlarged view of region E in the FIG.2.

FIG.8 is an enlarged view of region F in the FIG.2.

FIG.9 is an exposure view of the embodiment in accordance with an exemplary embodiment of the present invention.

FIG.10 is a diagrammatic depiction of the embodiment in accordance with the embodiment of the present invention showing the installation manner of the limiting annulation and the bushing on the column.

### Detailed description of the preferred embodiment

[0031] To enable a further understanding of the innovative and technological content of the invention herein, refer to the detailed description of the invention and the accompanying drawings below:

[0032] FIGS.1~18 show a preferable embodiment of the present invention.

[0033] In this embodiment, the extending ladder comprises:

- a left stile 1 and a right stile 2 which disposed oppositely; and
- a plurality of rungs 3 each extending between the left stile 1 and the right stile 2.

[0034] The left stile 1 is formed of telescopically collapsible left columns 11 which are disposed orderly in a nested arrangement for relative lengthwise movement in a telescopic fashion. The right stile 2 is also formed of telescopically collapsible right columns 21 which are disposed orderly in a nested arrangement for relative lengthwise movement in a telescopic fashion. The left columns 11 and the right columns 21 are in rough tubular shape.

[0035] Each rung 3 is mounted between the opposite two columns 11, 21. Each rung 3 is hollow and in rectangular figure. A left latch mechanism 4 is disposed in each rung 3 for locking the upper left column 11 with the corresponding rung 3 when the ladder extending lengthwise, to keep the ladder from collapsing. A right latch mechanism 5 is disposed in each rung 3 for locking the upper right column 21 with the corresponding rung 3 when the ladder extending lengthwise, to keep the ladder from collapsing. The left latch mechanism 4 and the right latch

mechanism 5 are respectively provided with a left button 6 and a right button 7 to operate the corresponding latch mechanism.

[0036] As shown in FIG.3 and FIG.7, the left latch mechanism 4 also comprises:

- a left pin 41 coupled to the left end of each rung 3, which makes the rung 3 be connected with the upper part of the corresponding left column 11;
- a left pin 42 disposed in each rung 3, which can move horizontally and transversely relatively to the corresponding rung 3 and can stick out of the left side of the corresponding rung 3;
- a first spring 43 disposed out of the left pin 42 to ensure the left pin 42 have a trend of sticking out of the left side of the rung 3;
- a first spring seat 44 is provided on the left side of the interior of the rung 3, which the left pin 42 can movably pass through, the first spring 43 is disposed in the first spring seat 44 with one end against the inner wall of the right side of the first spring seat 44 and the other end against a shoulder 421 protruded at the middle of the left pin 42; and
- a left limiting block 45 is provided on the left side of the interior of the rung 3, which the left pin 42 can movably pass through, and two stop rings 46 are provided on the left pin 42 in distance, which respectively locates at two sides of the left limiting block 45 and can respectively be stopped by the surface of two sides of the left limiting block 45; the left button 6 is connected with the left pin 42, correspondingly, a first locking holes 111 is provided on the top of the left column 11 for the corresponding left pin 42 to pass through, and a second locking holes 112 is provided on the middle of the left column 11 for the corresponding left pin 42 to insert into the left column 11.

[0037] As shown in FIG.4 and FIG.8, the right latch mechanism 5 also comprises:

- a right connector 51 is coupled to the right end of each rung 3, which makes the rung 3 be connected with the upper part of the corresponding right column 21;
- a right pin 52 is disposed in each rung 3, which can move horizontally and transversely relatively to the corresponding rung 3 and can stick out of the right side of the corresponding rung 3;
- a second spring 53 is disposed out of the right pin 52 to ensure the right pin 52 have a trend of sticking out of the right side of the rung 3;
- a second spring seat 54 is provided on the right side of the interior of the rung 3, which the right pin 52 can movably pass through, the second spring 53 is disposed in the second spring seat 54 with one end against the inner wall of the left side of the second spring seat 54 and the other end against a shoulder 521 protruded at the middle of the right pin 52; and

a right limiting block 55 is provided on the right side of the interior of the rung 3, which the right pin 52 can movably pass through, and two stop rings 56 are provided on the right pin 52 in distance, which respectively locates at two sides of the right limiting block 55 and can respectively be stopped by the surface of two sides of the right limiting block 55; the right button 7 is connected with the right pin 52, correspondingly, a third locking holes 211 is provided on the top of the right column 21 for the corresponding right pin 52 to pass through, and a fourth locking holes 212 is provided on the middle of the right column 21 for the corresponding right pin 52 to insert into the right column 21.

**[0038]** The left button 6 and the right button 7 are disposed closely with each other in the middle of the corresponding rung 3. That is, a left groove 31 and a right groove 32 are provided in the middle of the rung 3 respectively for the left button 6 and the right button 7 to pass through, the left button 6 and the right button 7 are respectively limited in the left groove 31 and the right groove 32 and can move breadthwise respectively relatively to the left groove 31 and the right groove 32. It makes two buttons 6, 7 be operated conveniently by single hand simultaneity to make the rung 3 released from the corresponding column 11; 21. The right side of the left button 6 is provided with a resisting portion 61, which is convenient for the fingertip to resist against, and the left side of the right button 7 is also provided with a resisting portion 71 which is convenient for the fingertip to resist against.

**[0039]** A left limiting annulation 8 is mounted around of the periphery surface of the middle of the left column 11, which is sandwiched between two adjacent left columns 11, correspondingly, the left connector 41 is provided with an annular wall to form a socket 411 which is preferably dimensioned to tightly connect with the periphery of the top of the left column 11, an inner shoulder 412 protruding inward is formed on the top of the inner wall of the socket 411 to stop the left limiting annulation 8, and the left connector 41 is also provided with a through hole 413 communicating with the socket 411 for the left pin 42 to pass through.

**[0040]** The left limiting annulation 8 is provided with a first gap 81 opposite to the first locking hole 111, and the inner wall of the left limiting annulation 8 is provided with a plurality of protrusions 82, correspondingly, the peripheral of the middle of the left column 11 is provided with a plurality of small holes 113 for the corresponding protrusion 82 to insert.

**[0041]** While a right limiting annulation 9 is mounted around of the periphery surface of the middle of the right column 21, which is sandwiched between two adjacent right columns 21, correspondingly, the right connector 51 is provided with an annular wall to form a socket 511 which is preferably dimensioned to tightly connect with the periphery of the top of the right column 21, an inner

shoulder 512 protruding inward is formed on the top of the inner wall of the socket 511 to stop the right limiting annulation 9, and the right connector 51 is also provided with a through hole 513 communicating with the socket 511 for the right pin 52 to pass through.

**[0042]** The right limiting annulation 9 is provided with a second gap 91 opposite to the third locking hole 211, and the inner wall of the right limiting annulation 9 is provided with a plurality of protrusions 92, correspondingly, the peripheral of the middle of the right column 21 is provided with a plurality of small holes 213 for the corresponding protrusion 92 to insert.

**[0043]** As shown in FIG.9 and FIG.10, a left bushing 10 is mounted around the opening of the bottom of the left column 11, the exterior surface 101 of the upper part of the left bushing 10 is in contact with the inner wall of the next lower left column 11, and the exterior surface 102 of the lower part of the left bushing 10 is tapered.

**[0044]** The internal surface of the upper part of the left bushing 10 is provided with a plurality of projects 103, correspondingly, the peripheral of the bottom of the left column 11 is provided with a plurality of location holes 114 for the corresponding project 103 to insert.

**[0045]** While a right bushing 12 is mounted around the opening of the bottom of the right column 21, the exterior surface 122 of the upper part of the right bushing 12 is in contact with the inner wall of the next lower right column 21, and the exterior surface 122 of the lower part of the right bushing 12 is tapered.

**[0046]** The internal surface of the upper part of the right bushing 12 is provided with a plurality of projects 123, correspondingly, the peripheral of the bottom of the right column 21 is provided with a plurality of location holes 214 for the corresponding project 123 to insert.

**[0047]** The operating principle and process of the embodiment of the present invention is as follows:

Here, only the action process of a working unit, which is composed of the left column 11, the right column 21, the rung 3 between two columns 11, 21, the upper columns of two columns 11, 21, is taken for an example.

**[0048]** The locking process of the right column 21:

After the right column 21 is pulled upward to be in position, the right limiting annulation 9 will be stopped by the matched inner shoulder 512 on the right connector 51, then the right column 21 is prevented from being pulling out further. Moreover, as the right limiting annulation 9 is stopped by the corresponding inner shoulder 512, it will indicate that the right column 21 has been in right position and the user should stop pulling. At this moment, the fourth locking holes 212 on the middle of the pulled right column 21 and the third locking holes 211 on the top of the next lower right column 21 both locate on the same axis. Therefore, under the function of the second spring

53, the right pin 52 locating in the rung 3 adjacent to the next lower right column 21 will be ejected out, and pass orderly through the through hole 513 on the right connector 51 and the third locking hole 211, then insert into the fourth locking hole 212, to lock the rung 3 and the upper right column 21. While the rung 3 is fixed with the other right column 21, accordingly, the rung 3, the right column 21 connected with the rung 3 and the upper right column 21 are interlocked with each other.

**[0049]** The locking process of the left column 11 is the same as the right column 21, and both processes are acting simultaneity.

**[0050]** The locking process of the right column 21 and the left column 11:

The user opens the thumb and the index finger of one (same) hand, taking the left hand as an example, the thumb touches the right button 7 and the index finger touches the left button 6, then, two fingers drives the left and right buttons respectively to move closely and closely with inward force at the same time, to make the left and right pin 42, 52 simultaneously move closely and closely. Accordingly, the left and right pin 42 will respectively break away from the second locking hole 112 and the fourth locking hole 212 on the upper corresponding column 11,21 at the same time, releasing the rung 3 from the upper left and right column 11,21. While the other hand (right hand) can hold the columns firmly.

**[0051]** When the upper left and right column 11, 21 moving, the exterior surface of the upper part of the left or right bushing 10, 12 on the bottom of the corresponding column will respectively contact and make friction with the inner wall of the next lower left or right column, the left and right bushing 10, 12 have the function of friction drag, to keep the upper left and right column 11, 21 from moving too fast respectively relatively to the next lower left and right column 11, 21. The damage of the rungs caused by the mutual clash between the adjacent rungs can be avoided and the noise caused by the mutual clash of the rungs can be reduced.

## Claims

1. An extending ladder comprising:

a left stile (1) and a right stile (2) which disposed oppositely;  
 a plurality of rungs (3) each extending between the left (1) stile and the right stile (2);  
 the left stile (1) formed of telescopically collapsible left columns (11) which are disposed orderly in a nested arrangement;  
 the right stile (2) formed of telescopically col-

lapsible right columns (21) which are disposed orderly in a nested arrangement;  
 and each rung (3) mounted between the opposite two columns (11, 21);

a left latch mechanism (4) disposed in each rung (3) for locking the upper left column (11) with the corresponding rung (3) when the ladder extending lengthwise, to keep the ladder from collapsing;

a right latch mechanism (5) disposed in each rung (3) for locking the upper right column (21) with the corresponding rung (3) when the ladder extending lengthwise, to keep the ladder from collapsing;

the left latch mechanism (4) and right latch mechanism (5) respectively provided with a left button (6) and a right button (7) to operate the corresponding latch mechanism;

**characterized in that** the left button (6) and the right button (7) disposed closely with each other in the middle of each rung (3), so as to make two buttons (6, 7) be operated conveniently by single hand to make the rung (3) released from the corresponding column (11; 21).

2. The extending ladder of claim 1, wherein the left latch mechanism (4) also comprises:

a left connector (41) coupled to the left end of each rung (3), which makes the rung (3) be connected with the upper part of the corresponding left column (11);

a left pin (42) disposed in each rung (3), which can move horizontally and transversely relatively to the corresponding rung (3) and can stick out of the left side of the corresponding rung (3);  
 and a first spring (43) disposed out of the left pin (42) to ensure the left pin (42) have a trend of sticking out of the left side of the rung (3);

the left button (6) is connected with the left pin (42), correspondingly, a first locking holes (111) is provided on the top of the left column (11) for the corresponding left pin (42) to pass through, and a second locking holes (112) is provided on the middle of the left column (11) for the corresponding left pin (42) to insert into the left column (11);

while the right latch mechanism (5) also comprises:

a right connector (41) coupled to the right end of each rung (3), which makes the rung (3) be connected with the upper part of the corresponding right column (21);

a right pin (52) disposed in each rung (3), which can move horizontally and transversely relatively to the corresponding rung (3) and can stick out of the right side of the

- corresponding rung (3);  
 and a second spring (53) disposed out of the right pin (52) to ensure the right pin (52) have a trend of sticking out of the right side of the rung (3);  
 the right button (7) is connected with the right pin (52), correspondingly, a third locking holes (211) is provided on the top of the right column (21) for the corresponding right pin (52) to pass through, and a fourth locking holes (212) is provided on the middle of the right column (21) for the corresponding right pin (52) to insert into the right column (21).
3. The extending ladder of claim 2, wherein a first spring seat (44) is provided on the left side of the interior of the rung (3), which the left pin (42) can movably pass through, the first spring (43) is disposed in the first spring seat (44) with one end against the inner wall of the right side of the first spring seat (44) and the other end against a shoulder (421) protruded at the middle of the left pin (42);  
 a second spring seat (54) is provided on the right side of the interior of the rung (3), which the right pin (52) can movably pass through, the second spring (53) is disposed in the second spring seat (54) with one end against the inner wall of the left side of the second spring seat (54) and the other end against a shoulder (521) protruded at the middle of the right pin (52).
4. The extending ladder of claim 2, wherein a left limiting block (45) is provided on the left side of the interior of the rung (3), which the left pin (42) can movably pass through, and two stop rings (46) are provided on the left pin (42) in distance, which respectively locates at two sides of the left limiting block (45) and can respectively be stopped by the surface of two sides of the left limiting block (45);  
 while a right limiting block (55) is provided on the right side of the interior of the rung (3), which the right pin (52) can movably pass through, and two stop rings (56) are provided on the right pin (52) in distance, which respectively locates at two sides of the right limiting block (55) and can respectively be stopped by the surface of two sides of the right limiting block (55).
5. The extending ladder of claim 2, wherein a left limiting annulation (8) is mounted around of the periphery surface of the middle of the left column (11), which is sandwiched between two adjacent left columns (11), correspondingly, the left connector (41) is provided with an annular wall to form a socket (411) which is preferably dimensioned to tightly connect with the periphery of the top of the left column (11), an inner shoulder (412) protruding inward is formed on the top of the inner wall of the socket (411) to stop
- the left limiting annulation (8), and the left connector (41) is also provided with a through hole (413) communicating with the socket (411) for the left pin (42) to pass through;  
 while a right limiting annulation (9) is mounted around of the periphery surface of the middle of the right column (21), which is sandwiched between two adjacent right columns (21), correspondingly, the right connector (51) is provided with an annular wall to form a socket (511) which is preferably dimensioned to tightly connect with the periphery of the top of the right column (21), an inner shoulder (512) protruding inward is formed on the top of the inner wall of the socket (511) to stop the right limiting annulation (9), and the right connector (51) is also provided with a through hole (513) communicating with the socket (511) for the right pin (52) to pass through.
6. The extending ladder of claim 5, wherein the left limiting annulation (8) is provided with a first gap (81) opposite to the first locking hole (111), and the inner wall of the left limiting annulation (8) is provided with a plurality of protrusions (82), correspondingly, the peripheral of the middle of the left column (11) is provided with a plurality of small holes (113) for the corresponding protrusion (82) to insert;  
 while the right limiting annulation (9) is provided with a second gap (91) opposite to the third locking hole (211), and the inner wall of the right limiting annulation (9) is provided with a plurality of protrusions (92), correspondingly, the peripheral of the middle of the right column (21) is provided with a plurality of small holes (213) for the corresponding protrusion (92) to insert.
7. The extending ladder of claim 1 or 2 or 3 or 4 or 5 or 6, wherein a left bushing (10) is mounted around the opening of the bottom of the left column (11), the exterior surface (101) of the upper part of the left bushing (10) is in contact with the inner wall of the next lower left column (11), and the exterior surface (102) of the lower part of the left bushing (10) is tapered;  
 while a right bushing (12) is mounted around the opening of the bottom of the right column (21), the exterior surface (122) of the upper part of the right bushing (12) is in contact with the inner wall of the next lower right column (21), and the exterior surface (122) of the lower part of the right bushing (12) is tapered.
8. The extending ladder of claim 7, wherein the internal surface of the upper part of the left bushing (10) is provided with a plurality of projects (103), correspondingly, the peripheral of the bottom of the left column (11) is provided with a plurality of location holes (114) for the corresponding project (103) to insert;

while the internal surface of the upper part of the right bushing (12) is provided with a plurality of projects (123), correspondingly, the peripheral of the bottom of the right column (21) is provided with a plurality of location holes (214) for the corresponding project (123) to insert. 5

- 9. The extending ladder of claim 1, wherein the right side of the left button (7) is provided with a resisting portion (71) which is convenient for the fingertip to resist against, and the left side of the right button (8) is also provided with a resisting portion (81) which is convenient for the fingertip to resist against. 10

15

20

25

30

35

40

45

50

55

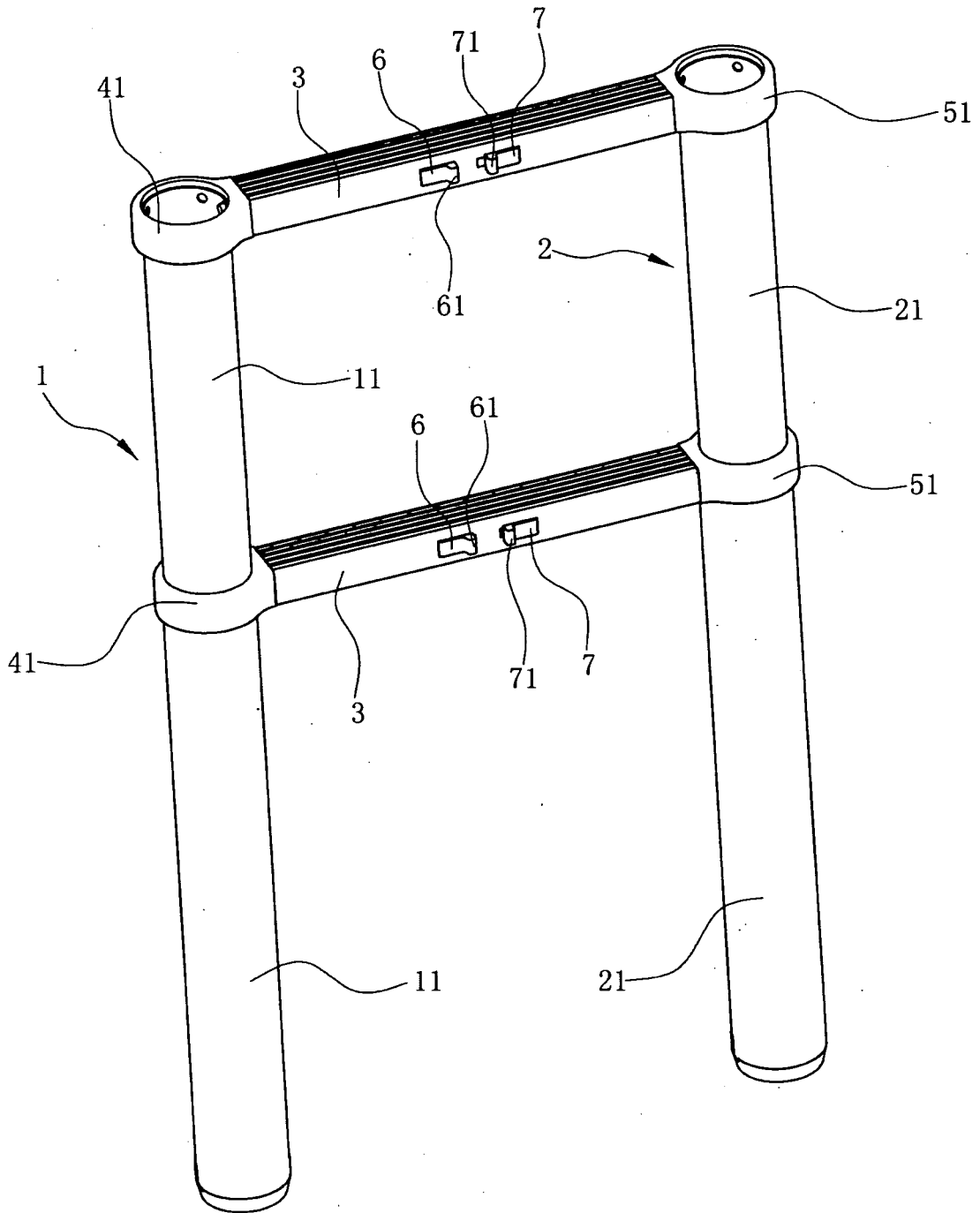

Fig. 1

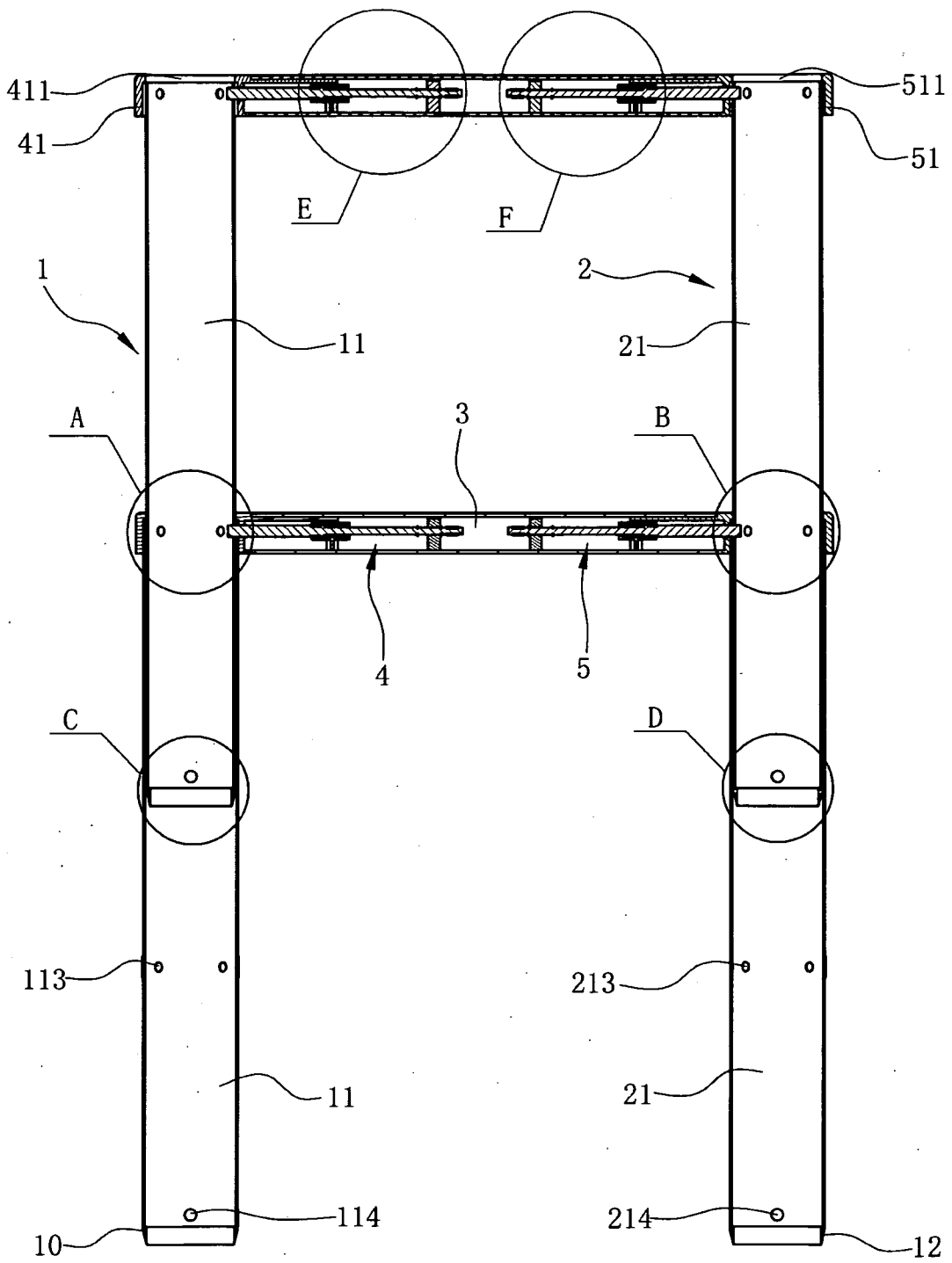

Fig. 2

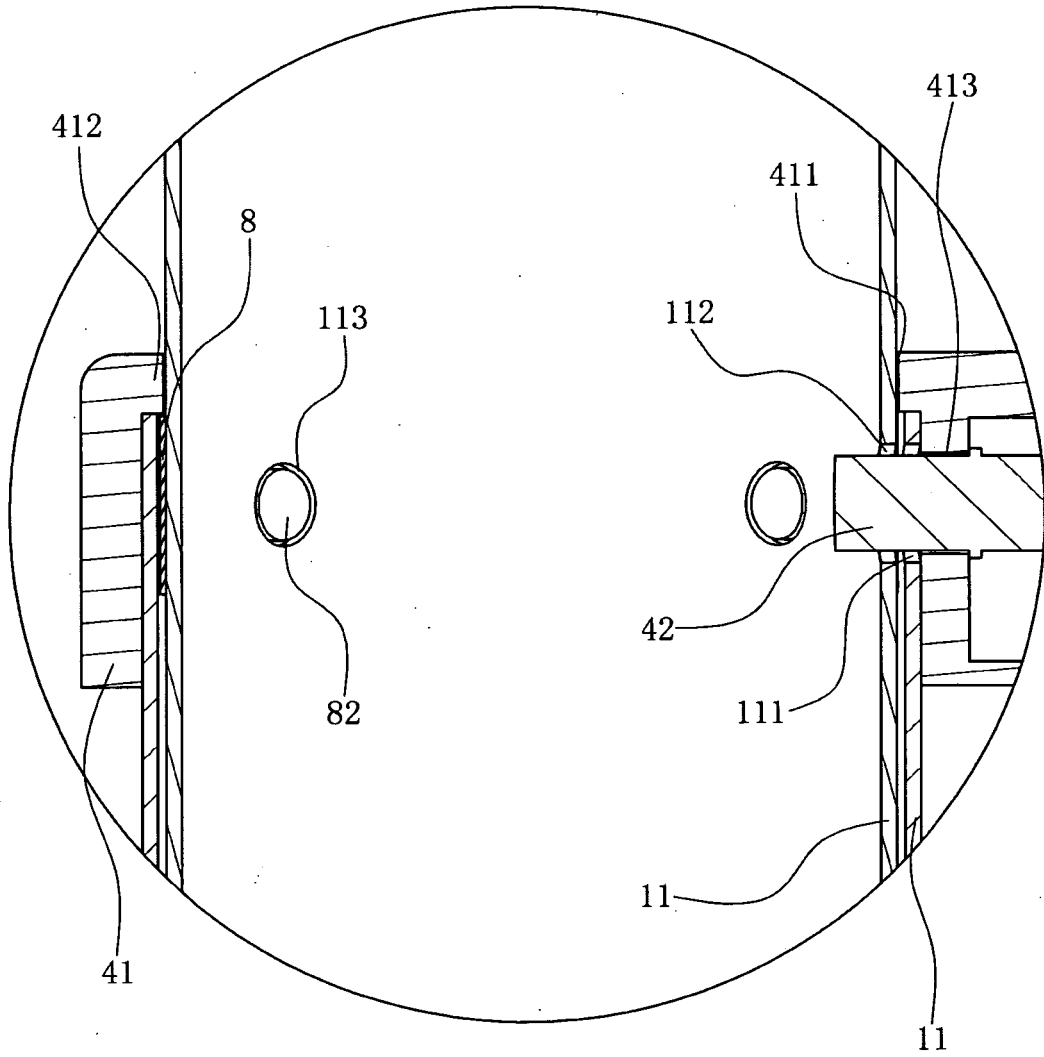

Fig. 3

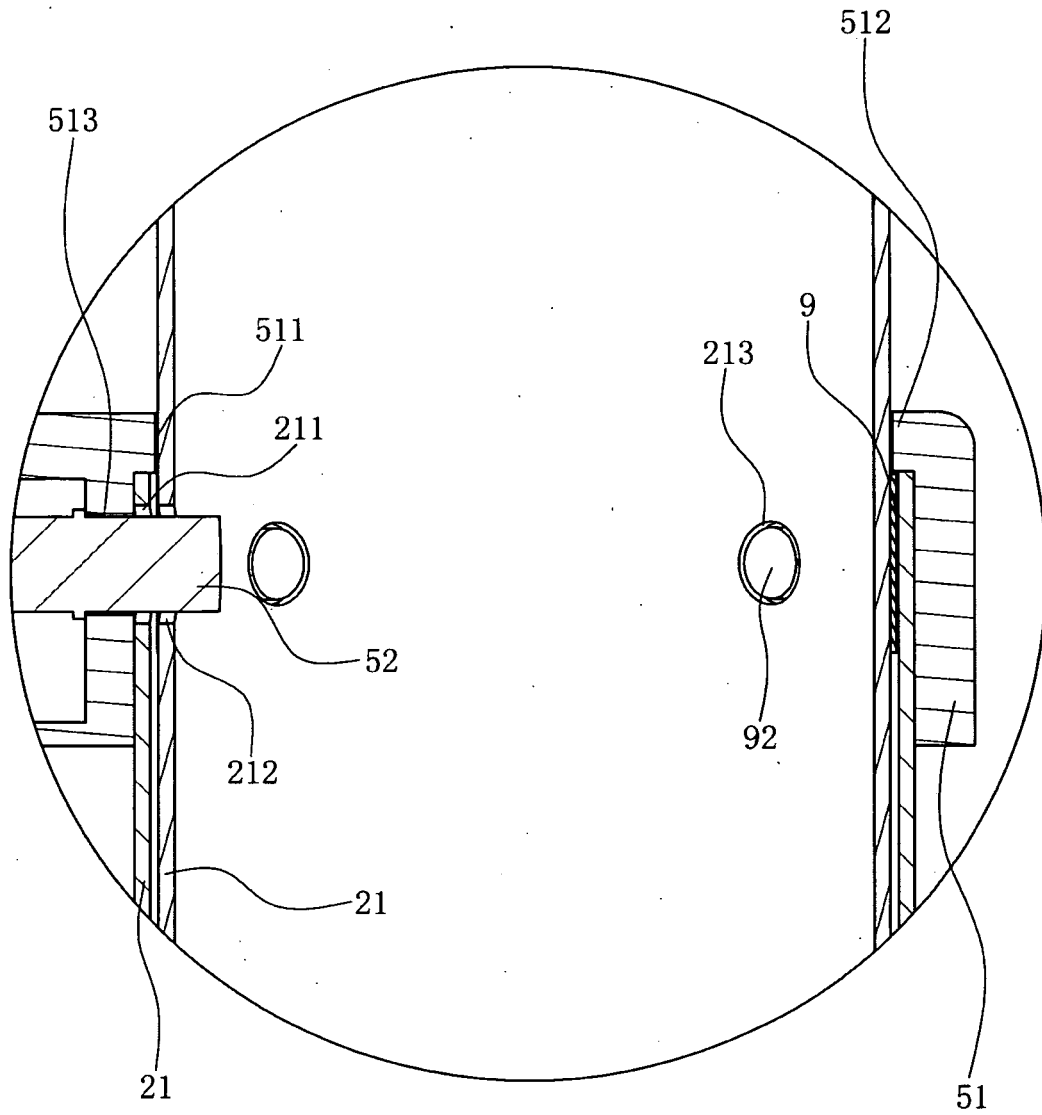

Fig. 4

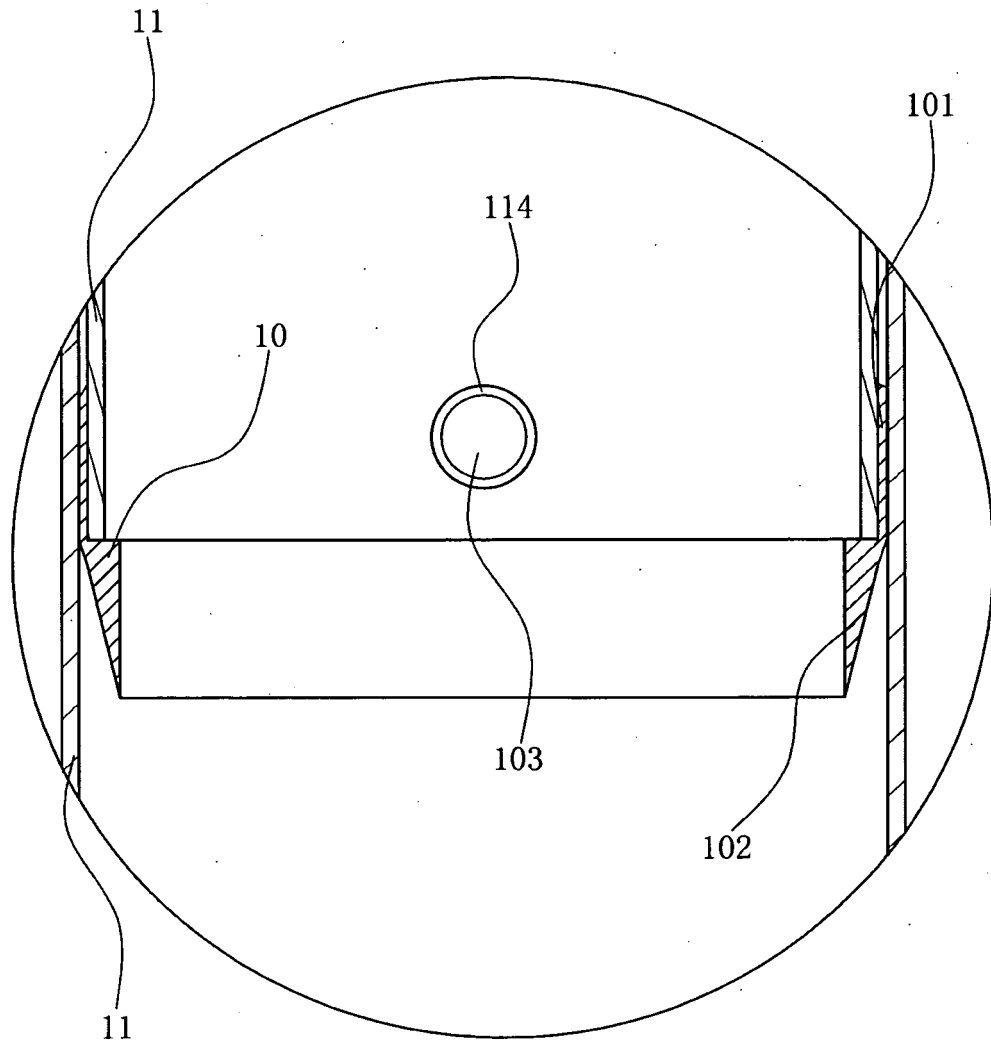

Fig. 5

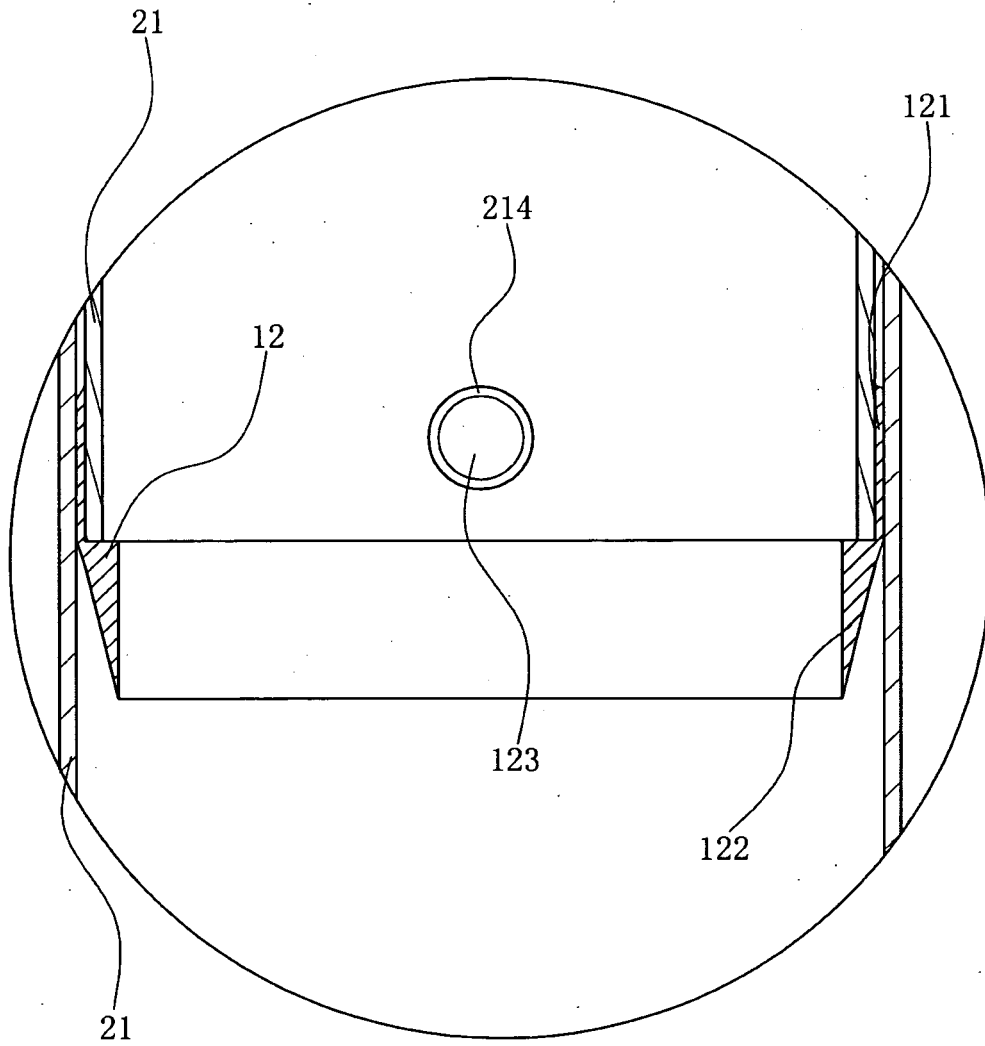

Fig. 6

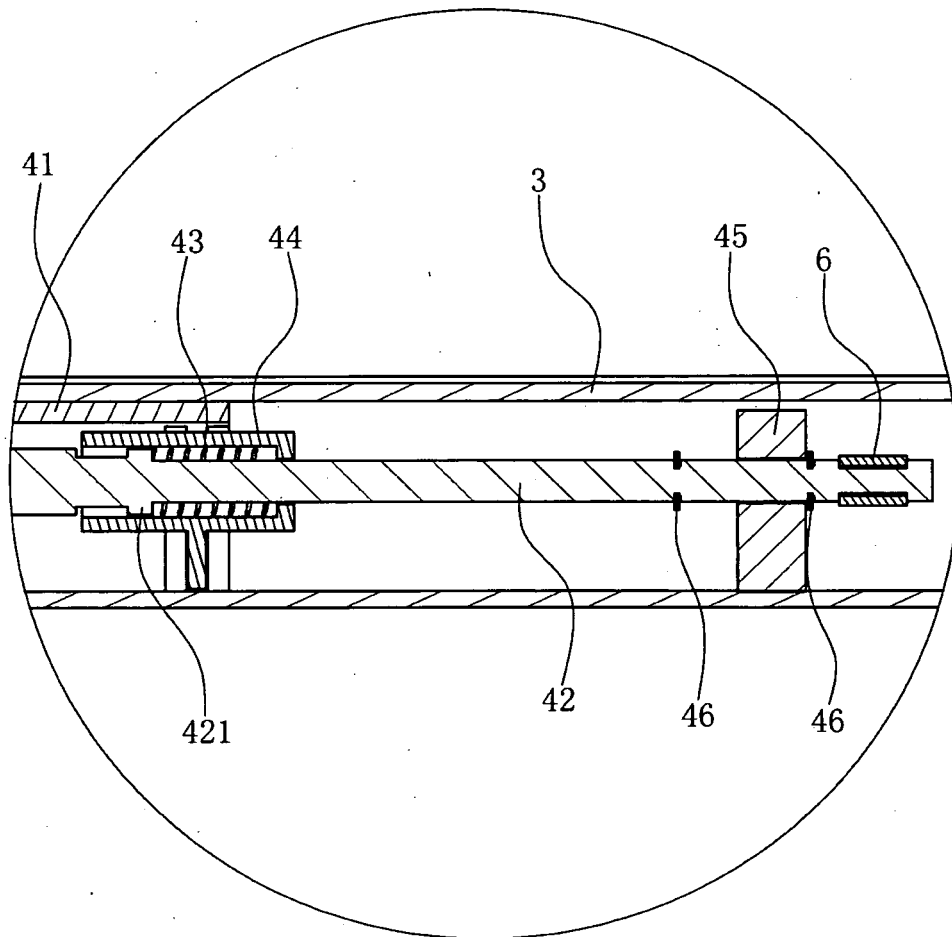

Fig. 7

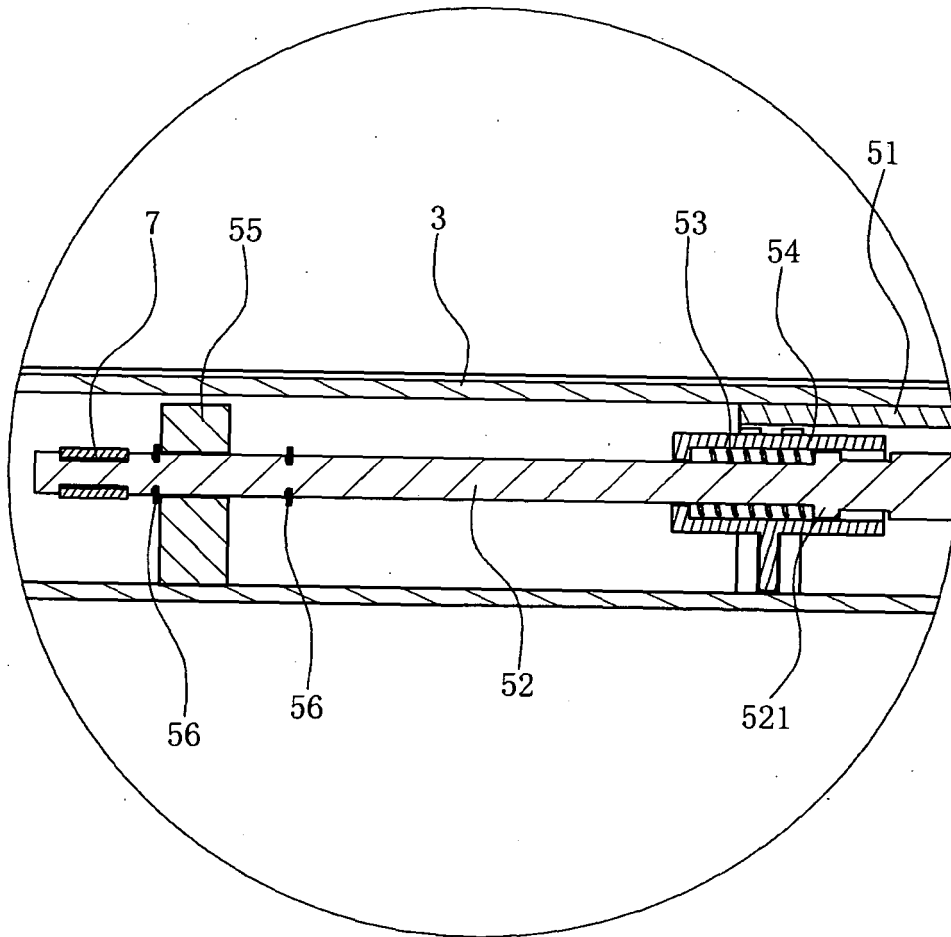

Fig. 8

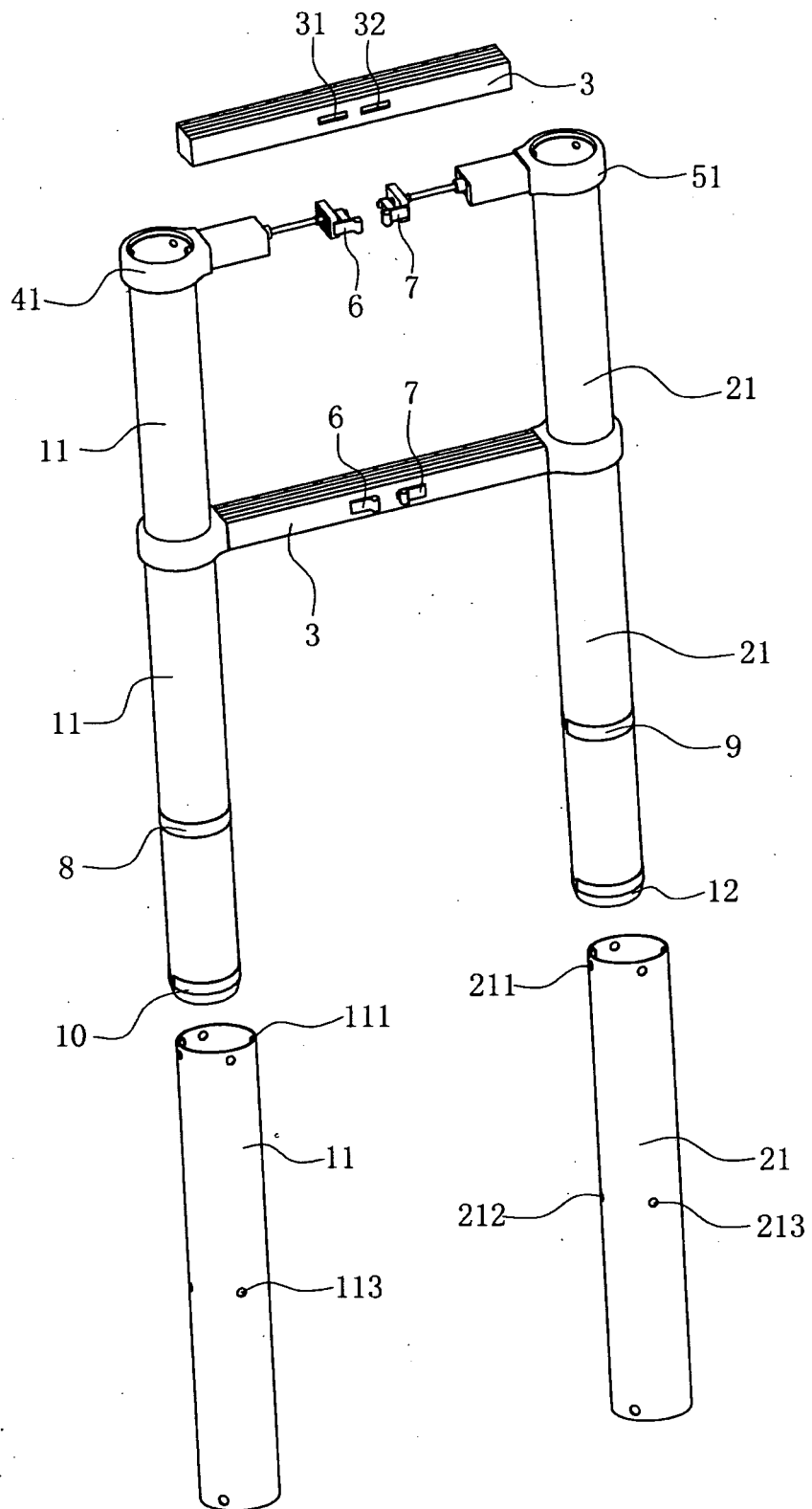

Fig. 9

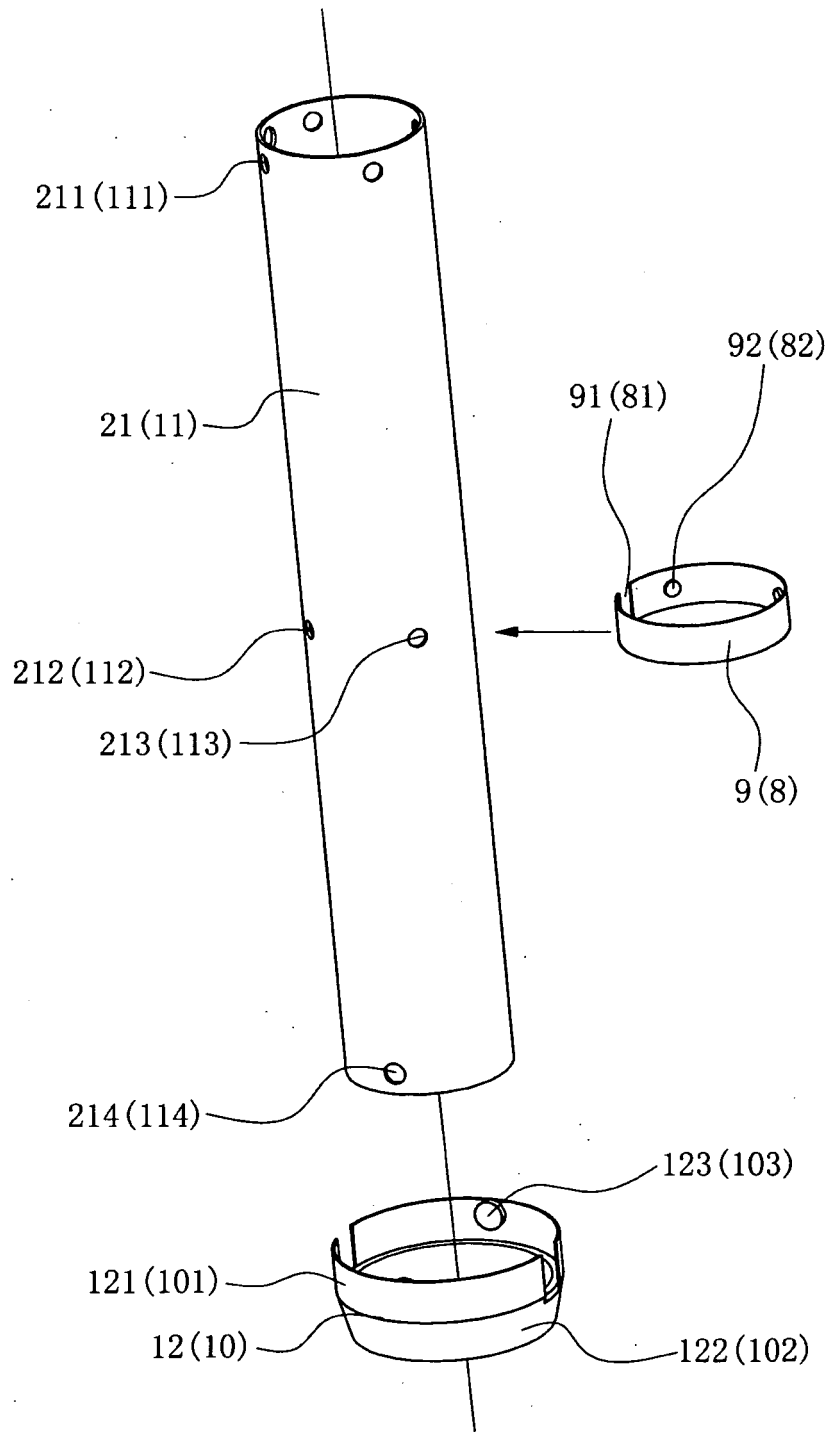

Fig. 10

## INTERNATIONAL SEARCH REPORT

International application No.

PCT/CN2009/000792

## A. CLASSIFICATION OF SUBJECT MATTER

See extra sheet

According to International Patent Classification (IPC) or to both national classification and IPC

## B. FIELDS SEARCHED

Minimum documentation searched (classification system followed by classification symbols)

IPC: E06C1/-,E06C7/-,

Documentation searched other than minimum documentation to the extent that such documents are included in the fields searched

Electronic data base consulted during the international search (name of data base and, where practicable, search terms used)

WPLEPODOC,PAJ,CNKI,CNPAT

extend+,collaps+,ladder,spring,button,rod,pin,lock,latch

## C. DOCUMENTS CONSIDERED TO BE RELEVANT

Category*	Citation of document, with indication, where appropriate, of the relevant passages	Relevant to claim No.
X	CN201047247 Y (JIAN, Shikun) 16Apr.2008 (16.04.2008)	1, 7, 9
Y	the abstract, page 4,line 6-23,page 5,line 14-20, Figs.1-5	2-6,8
Y	CN2881052 Y(HE,Haitao)21Mar.2007 (21.03.2007) page2,line 5-21,Figs.1-4	2-6,8
PX	CN201250602 Y(WANG, Wanxing)03Jun.2009 (03.06.2009) claims 1-9	1-9
A	CN200971751 Y(FANG,Gang) 07Nov.2007 (07.11.2007) the whole document	1-9
A	US7048094 B2(CORE DISTRIB INC)23May 2006 (23.05.2006) the whole document	1-9
A	EP0527766 B1(SAFESCAPE LTD)05Jun.1996 (05.06.1996) the whole document	1-9

 Further documents are listed in the continuation of Box C.
  See patent family annex.

* Special categories of cited documents:	“T” later document published after the international filing date or priority date and not in conflict with the application but cited to understand the principle or theory underlying the invention
“A” document defining the general state of the art which is not considered to be of particular relevance	“X” document of particular relevance; the claimed invention cannot be considered novel or cannot be considered to involve an inventive step when the document is taken alone
“E” earlier application or patent but published on or after the international filing date	“Y” document of particular relevance; the claimed invention cannot be considered to involve an inventive step when the document is combined with one or more other such documents, such combination being obvious to a person skilled in the art
“L” document which may throw doubts on priority claim (S) or which is cited to establish the publication date of another citation or other special reason (as specified)	“&” document member of the same patent family
“O” document referring to an oral disclosure, use, exhibition or other means	
“P” document published prior to the international filing date but later than the priority date claimed	

Date of the actual completion of the international search 09 Oct.2009 (09.10.2009)	Date of mailing of the international search report <b>29 Oct. 2009 (29.10.2009)</b>
Name and mailing address of the ISA/CN The State Intellectual Property Office, the P.R.China 6 Xitucheng Rd., Jimen Bridge, Haidian District, Beijing, China 100088 Facsimile No. 86-10-62019451	Authorized officer <b>LU,Xuehong</b> Telephone No. (86-10)62084883

Form PCT/ISA /210 (second sheet) (July 2009)

**INTERNATIONAL SEARCH REPORT**  
**Information on patent family members**

International application No.  
PCT/CN2009/000792

Patent Documents referred in the Report	Publication Date	Patent Family	Publication Date
CN201047247 Y	16. 04. 2008	None	
CN2881052 Y	21. 03. 2007	None	
CN201250602 Y	03. 06. 2009	None	
CN200971751 Y	07. 11. 2007	None	
US7048094 B2	23. 05. 2006	BR0313206 A	24. 07. 2007
		ES2276120 T	16. 06. 2007
		DE60311063 T	28. 06. 2007
		DK1448865 T	07. 05. 2007
		MXPA05001348 A	18. 10. 2005
		US2005139424 A1	30. 06. 2005
		US2004144596 A1	29. 07. 2004
		W02004013445 A1	12. 02. 2004
		EP1448865 A1	25. 08. 2004
		CA2497210 A1	12. 02. 2004
		AU2003256951 A1	23. 02. 2004
		US2004020718 A1	05. 02. 2004
EP0527766 B1	05. 06. 1996	W09115651 A	17. 10. 1991
		AU7665291 A	30. 10. 1991
		EP0527766 A1	24. 02. 1993
		BR9106325 A	20. 04. 1993
		JP5508456 T	25. 11. 1993
		GB2242925 A	16. 10. 1991
		US5495915 A	05. 03. 1996
		DE69120065 E	11. 07. 1996
		ES2089208 T3	01. 10. 1996
		CA2080135 C	19. 10. 1999
		GR3020598 T	31. 10. 1996
		DK0527766 T	24. 06. 1996

Form PCT/ISA /210 (patent family annex) (July 2009)

**INTERNATIONAL SEARCH REPORT**

International application No.

PCT/CN2009/000792

**A. CLASSIFICATION OF SUBJECT MATTER**

E06C 1/12 (2006.01) i

E06C 7/06 (2006.01) i

**REFERENCES CITED IN THE DESCRIPTION**

*This list of references cited by the applicant is for the reader's convenience only. It does not form part of the European patent document. Even though great care has been taken in compiling the references, errors or omissions cannot be excluded and the EPO disclaims all liability in this regard.*

**Patent documents cited in the description**

- EP 0527766 B1 [0003]
- US 7048094 B2 [0006]