

(12) PATENT
(19) AUSTRALIAN PATENT OFFICE

(11) Application No. AU 199863738 B2
(10) Patent No. 731942

(54) Title
Swivel

(51)⁷ International Patent Classification(s)
F16L 027/08 F16L 027/12

(21) Application No: **199863738**

(22) Application Date: **1998.04.30**

(30) Priority Data

(31) Number	(32) Date	(33) Country
08/841259	1997.04.30	US

(43) Publication Date : **1998.11.05**

(43) Publication Journal Date : **1998.11.05**

(44) Accepted Journal Date : **2001.04.05**

(71) Applicant(s)
Salter Labs

(72) Inventor(s)
Peter W Salter; James Noah Curti; Duane David Kazal; Laurence McGann

(74) Agent/Attorney
GRIFFITH HACK,GPO Box 4164,SYDNEY NSW 2001

(56) Related Art
WO 96/41092
US 5573280

ABSTRACT OF THE DISCLOSURE

A tubing end-piece interconnects a free end of a piece of tubing and a tubing connector or fitting so that a fluid can flow between the tubing and the fitting or connector.

5 The tubing end-piece includes a body member extending along a longitudinal axis with a bore extending longitudinally therethrough. The body member has an elongated body portion, a doughnut-shaped head portion and a frustoconically-shaped tail portion. The body portion has an outer body surface configured in a shape of a frustum that tapers from a first end and towards a second end. The doughnut-shaped head portion is connected to the first end of said body portion and extends radially outwardly relative to the longitudinal axis to form in cross-section an outer curved surface commencing from the first end and terminating in an outer peripheral edge which defines a first opening into the bore. A frustoconically-shaped tail portion is connected to the second end of the body portion and tapers from the second end and towards a second opening into the bore. The body member has an inner first surface and an inner second surface defining the bore and has a plurality of splines which are spaced apart from one another and extend longitudinally along and outwardly from the outer body surface. The present invention also includes a connector adapted to interconnect a pair of tubing end-pieces so that the fluid can flow between and through the respective pieces of tubing and the pair of tubing connectors, and present a connection which resists snagging when trailed from a portable or fixed source of oxygen gas to an ambulatory patient.

10

15

20

25

30

AUSTRALIA
Patents Act 1990

ORIGINAL
COMPLETE SPECIFICATION
STANDARD PATENT

Invention Title: SWIVEL

The following statement is a full description of this invention, including the best method of performing it known to us:

GH REF: P25388-D:MHK:RK

SWIVEL

5

FIELD OF THE INVENTION

10 The present invention relates to a tubing end-piece for use to connect tubing together. More particularly, the present invention is directed to a tubing end-piece body adapted to finish the end of a tubing so that it can be connected to tubing connectors. In turn, the connected tubing, end-piece and tubing connector will provide fluid tight communication for fluid flow therethrough.

BACKGROUND OF THE INVENTION

15 Although numerous ways are employed to connect tubing together, or to connect tubing to apparatus fittings and the like, it is conventional to provide the tubing with an elastomeric end-piece. Most typically, the end-piece is adhesively affixed to one of the free ends of the tubing.

20 Tubing fabricated from a stiff yet pliable material such as polyvinylchloride plastic is used extensively in the health care industry. Such tubing is used to convey oxygen from a portable oxygen source to ambulatory patients who suffer from respiratory illnesses or to convey intravenous solutions from containers and into patients for various medical reasons. Prior art tubing end-pieces and connectors are adequate to connect together two pieces of tubing in a fluid tight connection. Unfortunately, with ambulatory patients, these tubing end-pieces can become caught with furniture, under doors or in other places when a patient moves from one place to another. When this occurs, the ambulatory patient might cause one of the free ends of the tubing to disengage from any device to which the tubing may previously be connected to or catch and cause patient discomfort.

25

30

35

Typically, the prior art tubing end-pieces were fabricated from a stiff yet resilient material and included a body member having an elongated cylindrically-shaped body portion and a cylindrically-shaped head portion with a diameter larger than the body portion. These cylindrically-shaped portions of the tubing end-piece contributed to the problem of catching on furniture, under doors or in other items. A cylindrically-shaped bore extends longitudinally through both the body portion and the head portion. The head portion is used to assist in urging the tubing connector into engagement with a fitting. Although it is helpful to twist the prior art tubing end-piece while urging it into engagement with the fitting, gripping the tubing connector to obtain sufficient twisting force may cause the body portion to collapse. Thus, twisting a prior art tubing end-piece may have to be done carefully when attempting to engage a fitting because the fitting is cylindrical while the collapsed body portion may deform the cylindrically-shaped bore into an oval shape.

A need, therefore, exists to provide a tubing end-piece that is configured in a manner to avoid becoming caught with furniture, under doors or with other items while being moved by the patient. There is another need to provide an improved tubing end-piece so that it can be twisted while being connected to a fitting. There is likewise a need for a rigid tubing connector to releasably

connect two tubing end-pieces together in the fluid tight relationship.

At least preferred embodiments of the present invention provide a new and useful tubing end-piece and combination of end-piece and connector combined which are
5 configured in a manner to reduce the possibility of becoming caught with furniture, under doors or on other items.

Further, at least preferred embodiments of the present
10 invention provide a tubing end-piece and end-piece connector wherein the end-piece is sufficiently rigid and configured in a manner so that when urging the tubing end-piece onto a relatively rigid tubing connector or a fitting the bore of the end-piece resists substantial deformation.

Further, at least preferred embodiments of the present
15 invention provide a tubing connector with enhanced gripping characteristics so that the tubing end-piece can be easily gripped when twisting onto or off of a free end of the tubing connector or a fitting.

Further, at least preferred embodiments of the present
20 invention provide a tubing end-piece and connector that is effective in use and simple and inexpensive to manufacture.

The present invention will become more readily appreciated and understood from consideration of the
25 following detailed description of exemplary embodiments of the present invention when taken in conjunction with the

accompanying drawings.

In accordance with the present invention there is provided a swivel connector consisting of a body structure extending along a longitudinal axis from a first end to a second end and having a hole extending longitudinally through said body structure and between said first and second ends and being oriented centrally about said longitudinal axis, said body structure having an outer body structure extending longitudinally along and radially from said longitudinal axis at a first radial distance and said body structure includes a first body member piece having a bore and a second body member piece having a larger tapered bore, said first body member piece terminating at one end in a tube structure which is received within said second body member piece and extends beyond the end of said second body member piece said extension having a slightly larger diameter than the smallest diameter of the bore of the second body member piece which receives the tube structure, and said tube structure and extension being sized to permanently receive in rotational relationship with respect to said first body member piece said second body member piece and sealing means located between the tube of the first body member piece and the bore of the second body member piece to prevent gases from leaking through the bore of the second body member piece, said sealing means including a shoulder formed by a larger diameter untapered

portion of the tube located and complimentary diameter bore
of said second body member piece said bore diameter
extending sufficiently toward the tip of said structure to
receive an o-ring seal, and said body members on said body
5 structure including a pair of conical end portions each of
said conical end portions and a central body portion which
includes a plurality of V-shaped ridges extending
longitudinally along and projecting radially outwardly from
the central body portion relative to said longitudinal axis
10 and wherein the space between said conical end portion and
said central body portion contains a plurality of collars
having annular-shaped channels there between.

BRIEF DESCRIPTION OF THE DRAWINGS

15 Figure 1 is a perspective view of a preferred
embodiment of a tubing end-piece of the present invention;

Figure 2 is a cross-sectional view in elevation of the
tubing end-piece of the present invention shown in Figure
1;

20 Figure 3 is a cross-sectional view in elevation of the
tubing end-piece of the present invention taken along line
3 - 3 shown in Figure 2;

Figure 4 is a front elevational view of a head portion of the tubing connector of the present invention;

5 Figure 5 is a perspective view of a first exemplary embodiment of a connector according to the present invention;

10 Figure 6 is a side view in elevation of the first exemplary embodiment of the connector of the present invention shown in Figure 5 with a pair of tubing end-pieces and a pair of free ends of tubing with each being disconnected from one another;

Figure 7 is a front view and a rear view in elevation of the first exemplary embodiment of the connector of the present invention shown in Figure 5;

15 Figure 8 is a side view in cross section of the first exemplary embodiment of the connector of the present invention taken along line 8 - 8 in Figure 7 and illustrated interconnecting the pair of tubing end-pieces, drawn in phantom, connected to respective ones of the free ends of the tubing, also drawn in phantom, of Figure 6;

20 Figure 9 is a perspective view of a second exemplary embodiment of the connector of the present invention;

25 Figure 10 is a side view in elevation of the second exemplary embodiment of the connector of the present invention shown in Figure 9 with a pair of tubing end-pieces and a pair of free ends of tubing with each being disconnected from one another;

Figure 11 is a front view and a rear view in elevation of the second exemplary embodiment of the connector of the present invention shown in Figure 9;

30 Figure 12 is a side view in cross section of the second exemplary embodiment of the connector of the present invention taken along line 12 - 12 in Figure 11 and illustrated interconnecting the pair of tubing end-pieces, drawn in phantom, connected to respective ones of the free ends of the tubing, also drawn in phantom, of Figure 10;

35

Figure 13 is an exploded perspective view of a third exemplary embodiment of the connector of the present invention showing a first body member piece and a second body member piece which are releasably and rotatably connected to one another;

Figure 14 is a side view in cross-section of the third exemplary embodiment of the connector of the present invention illustrating the interconnection between the first and second body member pieces with a seal element disposed therewith;

Figure 15 is a side view in cross-section taken along line 15 - 15 in Figure 14;

Figure 16 is a side view in cross-section taken along line 16 - 16 of Figure 14;

Figure 17 is a side view in cross-section of the third exemplary embodiment of the connector showing an alternate means of releasably connecting the first and second body member pieces together;

Figure 18 is an enlarged partial side view in cross-section illustrating a seal element disposed between a tube stem of the first body member piece and a tube stem bore formed into the second body member piece;

Figure 19 is a perspective view of a fourth exemplary embodiment of the connector of the present invention and a splitter adapter for releasably connecting thereto;

Figure 20 is a side elevational view of a fifth exemplary embodiment of the connector of the present invention showing two pairs of stepped-down collars;

Figure 21 is a side elevation of one embodiment of a swivel connector according to the present invention;

Figure 22 is a cross sectional view of the swivel of Figure 21.

DETAILED DESCRIPTION OF THE EMBODIMENTS

A tubing end-piece of the present invention is adapted to interconnect and provide a fluid tight connection

between two pieces of tubing or a piece of tubing and a tubing connector or fitting so that a fluid can flow through the pieces of the interconnected tubing or to a fitting. It can be appreciated that the tubing described herein can be made from materials which produce a stiff yet resilient flexible tubing such as transparent or translucent tubing used in health care applications or rigid tubing fabricated from metal. The tubing can also be end portions of tubing projecting from fitting assemblies such as valves operably connected to tanks or other equipment. Furthermore, the stiff yet resilient tubing or the rigid tubing could be either removably force-fitted into the tubing connector of the present invention or permanently affixed to the tubing end-pieces described herein. One common arrangement is found in the health care industry where an ambulatory patient pulls or carries an oxygen concentrator or supply tank of gas or liquefied gas. Here, the first free end of a piece of tubing fabricated from a stiff yet resilient material is permanently affixed to one end of the tubing connector by an adhesive and a second piece of tubing fabricated from a metal which projects from a valve fitting assembly on the oxygen concentrator is removably connected to the tubing end-piece at an opposite end. This arrangement affords the patient to simply and easily remove or connect the tubing connector from the oxygen concentrator when desired, which is commonly referred to in the industry as a "quick disconnect".

A tubing end-piece 10 of the present invention is generally introduced in Figures 1 - 4. In Figure 1, tubing end-piece 10 receives free end 12 of a piece of tubing 14. Tubing connector 10 includes a body member 20 which extends along a longitudinal axis "A" with a bore 22 extending longitudinally therethrough. Body member 20 includes an elongated body portion 24 having an outer body surface 26

configured in a shape of a frustum tapering from a first end 28 and towards a second end 30. A doughnut-shaped head portion 32 is connected to first end 28 of body portion 24 and extends radially outwardly relative to longitudinal axis "A" to form in cross-section an outer curved surface 34 commencing from first end 28 and terminating in an outer peripheral edge 36. Outer peripheral edge 36 defines a first opening 38 into bore 22. First opening 38 is sized and adapted to slidably receive and retain a free end 12 of piece of tubing 14 in a close-fitting relationship. The first opening 38 should be sized and adapted to slidably receive and retain one tubular end of the connector shown in Figs. 5, 6 and 10. A frustoconically-shaped tail portion 40 (Fig. 2) is connected to second end 30 of body portion 24 and tapers from second end 30 and towards a second opening 42 into bore 22. Second opening 42 is sized and adapted to slidably receive and permanently retain a free end 16 of piece of tubing 18 in a close-fitting relationship.

Body member 20 includes an inner first surface 44 and an inner second surface 46 which define bore 22. Inner first surface 44 is disposed centrally about longitudinal axis "A" and forms a frustoconically-shaped first bore region 48 which converges inwardly from first opening 38 and through head portion 32. Inner second surface 46 is disposed centrally about longitudinal axis "A" and forms a frustoconically-shaped second bore region 50 which converges inwardly from second opening 42 and through tail portion 40 and body portion 24.

Tubing end-piece 10 also includes a ridge element 52 which is connected to and extends circumferentially about inner second surface 46. Ridge element 52 is disposed substantially midway between first and second openings 38 and 42, respectively. Ridge element 52 acts as a stop to

prevent the free end of the tubing from advancing therebeyond when inserted into the bore.

5 Tubing end-piece 10 further includes a plurality of splines 54 which are spaced apart from one another and extend longitudinally along outer body surface 26 of body portion 24. Each of splines 54 is connected to outer body surface 26 of body portion 24 and outer curved surface 34 of said head portion 32. Splines 54 add rigidity to tubing connector 10 and also provide additional frictional characteristics thus allowing twisting of tubing connector 10 when engaging a free end of tubing.

10 Although not by way of limitation, it is preferred that body member 20 is fabricated of unitary construction. Again, not by way of limitation, flexible body member 20 is
15 fabricated from a stiff yet resilient material selected from a group consisting of various rubber or plastic compositions. It is further preferred that the stiff yet resilient material is transparent or translucent. Having a tubing end-piece fabricated from a transparent or
20 translucent material enables a user to visually determine that, when engaging free ends of tubing with tubing end-piece 10, the free ends are appropriately inserted into the bore and in abutment with the ridge element.

25 Both the body portion and the tail portion of the tubing end-piece of the present invention are configured to taper. The head portion of the tubing end-piece has a doughnut-shaped configuration. These configurations of the tubing end-piece enable it to avoid becoming caught with furniture, under doors and in other items. With the
30 splines, the tubing end-piece is sufficiently rigid so that when urging the tubing end-piece onto a tubing connector or a fitting, the bore resists deformation. Thus, the tubing end-piece of the present invention is easier to install onto the free end of a tubing connection or a valve
35 fitting. Furthermore, the tubing end-piece of the present

invention has enhanced gripping characteristics because of the splines. Now, the tubing connector can be more easily gripped so that it can be twisted onto or off of a free end of a tubing connector. Lastly, a skilled artisan would appreciate that the tubing end-piece of the present invention is effective in use and simple and inexpensive to manufacture.

5
10
15
20
25
A first exemplary embodiment of the connector 210 of the present invention is generally introduced in Figures 5 - 8. Connector 210 is used in combination with a pair of tubing end-pieces 10 such as ones described hereinabove or some other type tubing end-pieces of similar construction. By way of example only, the description of the exemplary embodiments of connector 210 shall be explained by incorporating tubing end-piece 10 of the present invention as heretofore described. Each tubing end-piece 10 is connected to the free end 16 of tubing 18 and has first opening 38 into bore 22 wherein the fluid (shown as arrows in Figure 8) can flow through respective ones of tubing end-piece 10 and a connector or tubing 18. Connector 210 is adapted to interconnect the pair of tubing end-pieces 10 so that the fluid can flow between and through the respective pieces of tubing 14 and 18 (see Fig. 6). Connector 210 includes a body structure 212 and a pair of tube structures 214.

30
Body structure 212 extends along a longitudinal axis "A'" from a first end 216 to a second end 218. As best shown in Figure 8, body structure 211 has a hole 220 extending longitudinally therethrough and between first end 216 and second end 218. Hole 220 is oriented centrally about longitudinal axis "A'". As best shown in Figures 5 - 7, body structure 212 has an outer body surface 222 which extends longitudinally along and disposed radially from longitudinal axis "A'" at a first radial distance "R₁".

As best shown in Figure 8, each of tube structures 214 defines a conduit 224 which extends therethrough and each of tube structures 214 has a distal end 226 and a proximal end 228. Each of tube structures 214 is connected to a
5 respective one of first and second ends 216 and 218 of body structure 212 at proximal end 228. When connected, each conduit 224 is oriented centrally about longitudinal axis "A'" so that conduits 224 and hole 220 form a continuous
10 passageway 230 between distal ends 226 of the pair of tube structures 214 and through the pair of tube structures 214 and body structure 212. Each of tube structures 214 has an outer tube surface 232 which extends longitudinally along and radially from longitudinal axis "A'" at a second radial distance " R_2 " as best shown in Figure 8. To facilitate the
15 ease of connecting or disconnecting connector 210 to the pair of tubing end-pieces 10, first radial distance " R_1 " is greater than second radial distance " R_2 " at least by a factor of 1.5, i.e., 1.5 times " R_2 ".

Body structure 212 is generally cylindrically shaped.
20 Both body structure 212 and the pair of tube structures 214 are preferably fabricated of unitary construction. Also, body structure 212 and the pair of tube structures 214 are preferably fabricated from a stiff material such as plastic, fiberglass, wood or metal. Body structure 212
25 includes a pair of conical end portions 234. Each of conical end portions 234 tapers from outer body surface 222 towards a respective one of first and second ends 216 and 218. Body structure 212 includes a plurality of ridges 236 extending longitudinally along and projecting radially
30 outwardly from outer body surface 222 relative to longitudinal axis "A'". Each of ridges 236 is configured in cross-section in a shape of an inverted "V" as best shown in Figure 7.

Each of tube structures 214 includes a plurality of
35 collars 238 which are connected to and extend

circumferentially about and radially outwardly from outer tube surface 232. The plurality of collars 238 are spaced apart from one another to define an annularly-shaped channel 240, as best shown in Figure 5, which is disposed between consecutive ones of collars 238. Each of said tube structures 214 also includes a frustoconically-shaped head member 242 which is disposed on and extends circumferentially about outer tube surface 232. Head member 242 commences at distal end 226 and diverges outwardly toward body structure 212. It is to be appreciated that each of the pair of tube structures 214 is operative to be removably inserted through first opening 38 and into bore 22 of a respective one of tubing end-pieces 10 so that connector 210 engages both of the tubing connectors 10 in a closely fitting relationship (as shown in Figure 8) thereby enabling the fluid to flow between and through the respective pieces of tubing 14 and 18, as well as presenting a smooth nearly continuous exterior surface which resists snagging in use.

A second exemplary embodiment of a connector 310 of the present invention is generally introduced in Figures 9 - 12. Features and benefits of this second exemplary embodiment of the connector 310 are substantially similar to those of the first exemplary embodiment. The only difference resides in a configuration of a plurality of ridges 338. Connector 310 includes a body structure 312 and a pair of tube structures 314. Outer body surface 322 is represented by a plurality of lines as shown in Figures 9 - 11. Each of ridges 338 is configured in cross-section in a shape of an inverted "V", as best shown in Figure 11, and consecutive ones of the plurality of inverted V-shaped ridges 338 are spaced apart from one another by a V-shaped channel 339 which extends longitudinally along body structure 312.

A third exemplary embodiment of a connector 410 is introduced in Figures 13 - 16. Connector 410 is similar to the connectors hereinabove described except that the body structure includes a first body member piece 446 and a second body member piece 448. First body member piece 446 and second body member piece 448 are releasably interconnected with one another and are operative to rotate about longitudinal axis "A'" relative to each other. One of first and second body member pieces 446 and 448 includes a tube stem 450 extending longitudinally and projecting outwardly therefrom in a direction opposite of a respective one of tube structures 214, as best shown in Figure 13. Tube stem 450 has a tube stem conduit 452 extending therethrough and is disposed centrally about longitudinal axis "A'". A remaining one of first and second body member pieces 446 and 448 includes a tube stem bore 454 which is formed longitudinally thereinto along longitudinal axis "A'" and is sized and adapted to slidably and rotatably receive tube stem 450. Tube stem bore 454 extends partially through the remaining one of first and second body members 446 and 448 and disposed centrally about longitudinal axis "A'". By way of example only for the third embodiment of connector 410, first body member piece 446 has been selected to include tube stem 450 and second body member piece 448 has been selected to include tube stem bore 454 although a skilled artisan would appreciate that second body member piece 448 could have been selected to include tube stem 450 while first body member piece 446 would then include tube stem bore 454.

As best shown in Figures 13 and 14, tube stem 450 has a proximal cylindrical end portion 456, an intermediate conical portion 458 and a distal frustoconical nose portion 460. Tube stem bore 454 is a step-down bore which accommodates tube stem 450 for sliding and rotating therein in a close-fitting relationship. Tube stem 450 includes a

groove 462 which extends circumferentially around proximal cylinder end portion 456. As shown in Figures 13, 15 and 16, second body member piece 448, i.e., the remaining one of first and second body member pieces 446 and 448, includes a cavity 464 which extends transversely to longitudinal axis "A'" and from outer body surface 222 and in communication with tube stem bore 454.

Connector 410 of the third exemplary embodiment of the present invention includes a fastener 466 which is sized and adapted to be slidably received by cavity 464 in a close-fitting relationship as shown in Figure 16. Fastener 466 is operative in conjunction with cavity 464 to engage a portion of groove 462 (Figures 14 and 16) so that first and second body members 446 and 448 are rotatably interconnected with one another. Fastener 466 has a pair of arms 468 which are disposed parallel with one another and are connected together in a manner to form a U-shaped clip element. Shown in Figures 14 and 16, each of arms 468 sized and adapted to engage a portion of groove 462 when fastener 466 is slidably received by cavity 464.

As shown in Figure 17, first body member piece 446 and second body member piece 448 are rotatably connected together in an alternative manner. Cavity 464 includes a pair of fastener holes 472 which are disposed parallel to one another and transverse to and on opposite sides of longitudinal axis "A'". Fastener 466 includes a pair of pins 474 which are sized and adapted to engage respective ones of fastener holes 272 in a mating relationship.

With reference to Figures 13 and 14, connector 410 of the third exemplary embodiment of the present invention also includes an annularly-shaped seal element 470. Seal element 470 is sized and adapted to be centrally positioned within tube stem bore 454 so that it surrounds longitudinal axis "A'" while being in contact with distal frustoconical nose portion 460 of tube stem 450 when tube stem 450 is

rotatably received into tube stem bore 454. Seal element 456 is a common O-ring fabricated from a resilient material such as rubber or any other convention type of material commonly used for sealing purposes of this type.

5 In Figure 18, intermediate conical portion of tube stem 450 and distal frustoconical nose portion 460 of tube stem 450 are joined together by a collar portion 476. In cross-section, collar portion 476 is formed with a radius "r" and is offset from an outer conical surface 478 a distance "d". Note that seal element 470 is nestled in an annular opening 480 and is in contact with an outer frustoconical surface 482 of distal frustoconical nose portion 460 and inner peripheral wall 484 and an inner radial wall 486 which, in part, defines tube stem bore 454.

10 Outer frustoconical surface 482 tapers at an angle "a" relative to longitudinal axis "A", which is preferably 20 degrees. As a result of nestling, seal element 470 provides adequate sealing of fluid flowing through continuous passageway 230 as long as the fluid flows under relatively low pressure indicated by pressure "P". Under higher pressure, indicated by "P'", seal element 470 tends to be displaced away from inner radial wall 486. However, simultaneously, seal element 470 becomes increasingly wedged between inner peripheral wall 484 and outer frustoconical surface 482 of distal frustoconical nose portion 460 as illustrated in phantom. As a result of wedging, with increased fluid pressure, the sealing characteristics of seal element 470 also increases. A skilled artisan would appreciate that this feature can only operate within a reasonable zone of high pressures and that excessive pressures can possibly result in catastrophic failure of the connector of the present invention itself.

15

20

25

30

35 Figure 19 shows a fourth exemplary embodiment of a connector 510 of the present invention of a type whereby first body member piece 446 and second body member piece

448 can rotate relative to each other. One of tube structures 214 has a straight end 512 which is sized and adapted to receive a splitter adapter 514. Splitter adapter 514 includes a head member 516 and a pair of tube members 518. Head member 516 has a head conduit 520 formed therein that extends longitudinally and centrally about longitudinal axis "A" and is sized and adapted to slidably receive straight end portion 512 in a matable relationship. Each of the pair of tube members 518 has a tubing conduit 522 that merges into head conduit 520 so that fluid flowing from connector 510 and into splitter adapter 514 can be divided into two separate flowing fluids. Conversely, two separate flowing fluids flowing from each tubing conduit 522 merge into one flowing fluid at head member 516.

A fifth exemplary embodiment of a connector 610 is illustrated in Figure 20. Like the exemplary embodiments of the connector of the present invention described hereinabove, connector 610 includes a pair of tube structures 614 with each having a plurality of collars 638. However, unlike the previously described exemplary embodiments of the connector of the present invention, each plurality of collars 638 includes a primary sealing collar 688 having a primary collar diameter " d_p " and a secondary sealing collar 690 having a secondary collar diameter " d_s ". Primary sealing collar 688 and secondary sealing collar 690 are facially opposed to one another as shown in Figure 20 with primary collar diameter " d_p " being greater than secondary collar diameter " d_s ". Although not by way of limitation, respective ones of each of primary sealing collars 688 are positioned between respective ones of each of secondary sealing collars 690 and respective ones of first and second ends 216 and 218 of body structure 212.

Each of the plurality of collars 638 includes an inner-most collar 692. Each inner-most collar 692 is connected to a respective one of first and second ends 216

and 218 of body structure 212 and extends from proximal end 228 of tube structure 214 and toward distal end 226. Each of inner-most collars 692 has an inner collar diameter " d_i ". Primary collar diameter " d_p " is greater than inner-most collar diameter " d_i "; however, inner-most collar diameter " d_i " is greater than secondary collar diameter " d_s ".

Further, each of the plurality of collars 638 includes an outer-most collar 694 having an outer collar diameter " d_o ". With respect to the other collar diameters, it is preferred that the secondary collar diameter " d_s " is greater than outer collar diameter " d_o ". Each of outer-most collars 694 is integrally connected to and inboard of a respective one of head members 242 and is disposed between respective ones of head members 242 and secondary sealing collars 690.

A skilled artisan would appreciate that the broadest diameter of respective ones of head members 242 is equal to outer collar diameter " d_o ".

As mentioned hereinabove, the connector of the present invention includes conical end portions 234 that taper from outer body surface 222 towards a respective one of first and second ends 216 and 218. Although not by way of limitation, it is preferred that conical end portions 234 taper from outer body surface 222 towards a respective one of first and second ends 216 and 218 at an acute angle of 45 degrees relative to longitudinal axis "A".

In yet another embodiment, the swivel connector 701 shown in Figures 21 and 22 is a two-piece swivel connector having a swivel body end 702 with the increasing diameter spaced concentric rings 704 and 705, as described herein, and a tubular extension 706 terminating in a flanged tip 707 of a greater diameter than the outside diameter of the tubular extension 706 at the position 710. The tubular extension 706 can be characterized as beginning at the midpoint 720 of the overall length of the swivel connector 701 and having a diameter larger than the diameter at 710

for a length less than the length of one-half of the center section 722 of the swivel connector 701. The space between the larger diameter section 723 of the tubular extension 706 and the depth of the hole 725 in the center section 722 which is sized to receive the section 725, is taken up with an O-ring 730 sized to provide a sliding fluid tight fit between the inner surface 726 of the hole 725, and smaller diameter section 731 of the tubular extension 706. Preferably, the O-ring 730 is received in a recess 735 formed in the surface of the tubular extension 706 immediately adjacent the larger diameter section 723. The swivel end 750 which contains center section 722 and tubing connector shaft 751, is configured with concentric rings which are sized identically with the swivel body end 702. The exterior of swivel end 750 is then in all respects except the end 755 abutting the flange 707 identical in its exterior dimensions to the dimensions of swivel body end 702.

When assembled, swivel body end 702 and swivel end 750, which is received onto the tubular extension 706 in locking relationship with flange 707 can be used as a connector between two lengths of tubing for delivering a fluid, preferably a gas, and most preferably oxygen, which can be rotated without leakage of the gas while still presenting an outside configuration which can be easily gripped and twisted and containing sealing rings for fluid tight contact with tubing while being easily mounted therein and removed therefrom.

This embodiment, being of two-piece construction, is more easily manufactured than more complicated swivel mechanisms. The inside bore of swivel end 751 increases in diameter from the flange 707 of the tubular extension 706 to the O-ring 730 to provide ease of assembly but is sized to permit the O-ring 730 to make a fluid tight seal for fluids including gases that might be introduced at the

flange 707 and the end 755 of the swivel end 751. The volume of annular space 760 then increases from the end 755 to the O-ring. The two parts can then be snapped together with the O-ring 730 in place if the flange 707 and the diameter of the bore 751 at the O-ring 730 are sized so that the flange is able to be inserted into the bore 750 and slid through the bore compressing enough to emerge in a rotatable fit for the swivel end 751.

The tubing end-piece and the combination of the tubing end-piece and connector provide numerous advantages and benefits. The tubing end-piece and combination of end-piece and connector are configured in a manner to reduce the possibility of becoming caught with furniture, under doors or on other items. The tubing end-piece and end-piece connector have ends that are sufficiently rigid and configured in a manner so that, when urging the tubing end-piece onto a relatively rigid tubing connector or a fitting, the bore of the end-piece resists substantial deformation. The tubing end-piece as well as the connector have enhanced gripping characteristics so that each can be easily gripped when twisting onto or off of each other or some other fitting. Both the tubing end-piece and the connector are effective in use and simple and inexpensive to manufacture.

Accordingly, the present invention has been described with some degree of particularity directed to the exemplary embodiments of the present invention. It should be appreciated, though, that the present invention is defined by the following claims construed in light of the prior art so that modifications or changes may be made to the exemplary embodiments of the present invention without departing from the inventive concepts contained herein.

THE CLAIMS DEFINING THE INVENTION ARE AS FOLLOWS:

1. A swivel connector consisting of:

a body structure extending along a longitudinal axis from a first end to a second end and having a hole
5 extending longitudinally through said body structure and between said first and second ends and being oriented centrally about said longitudinal axis, said body structure having an outer body structure extending longitudinally along and radially from said longitudinal axis at a first
10 radial distance and said body structure includes a first body member piece having a bore and a second body member piece having a larger tapered bore, said first body member piece terminating at one end in a tube structure which is received within said second body member piece and extends
15 beyond the end of said second body member piece said extension having a slightly larger diameter than the smallest diameter of the bore of the second body member piece which receives the tube structure, and said tube structure and extension being sized to permanently receive
20 in rotational relationship with respect to said first body member piece said second body member piece and sealing means located between the tube of the first body member piece and the bore of the second body member piece to prevent gases from leaking through the bore of the second
25 body member piece, said sealing means including a shoulder formed by a larger diameter untapered portion of the tube located and complimentary diameter bore of said second body

member piece said bore diameter extending sufficiently toward the tip of said structure to receive an o-ring seal, and said body members on said body structure including a pair of conical end portions each of said conical end portions and a central body portion which includes a plurality of V-shaped ridges extending longitudinally along and projecting radially outwardly from the central body portion relative to said longitudinal axis and wherein the space between said conical end portion and said central body portion contains a plurality of collars having annular-shaped channels there between.

2. A swivel connector substantially as herein described with reference to Figures 21 and 22 of the accompanying drawings.

Dated this 29th day of April 1998

SALTER LABS
By their Patent Attorney
GRIFFITH HACK



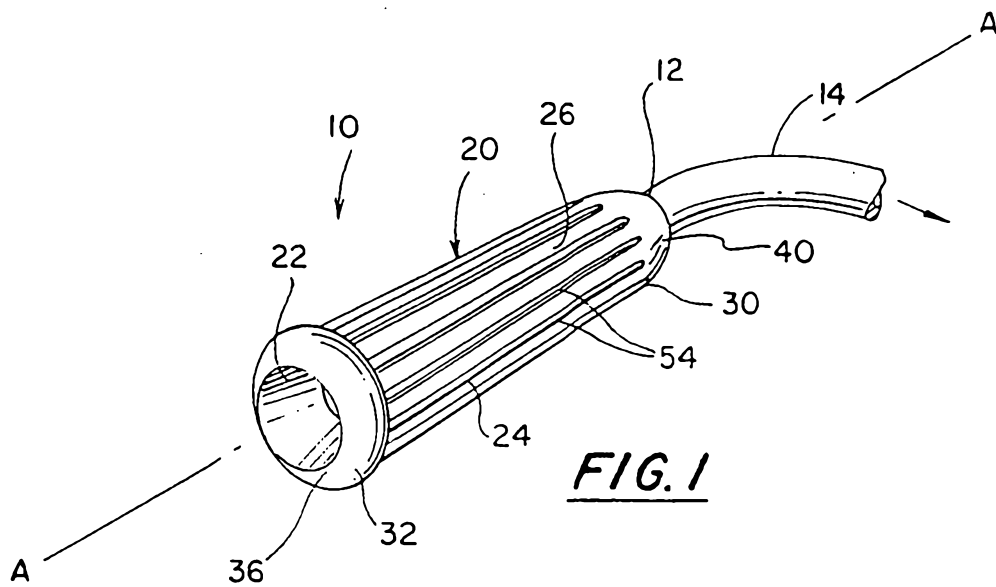

FIG. 1

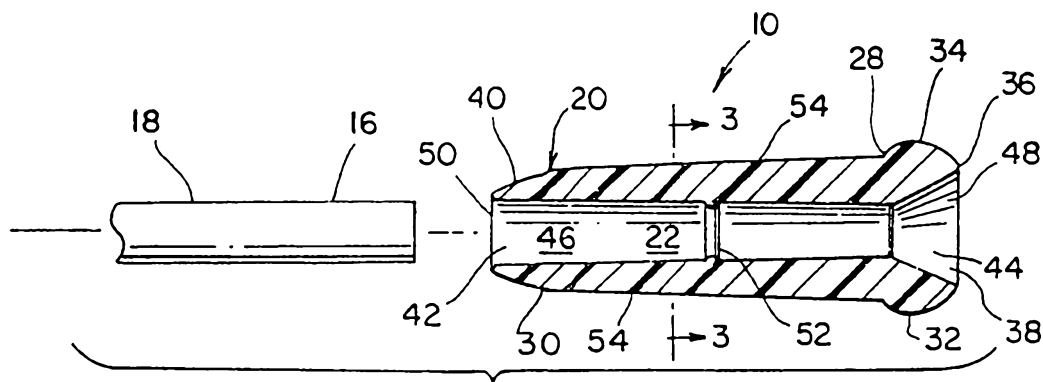

FIG. 2

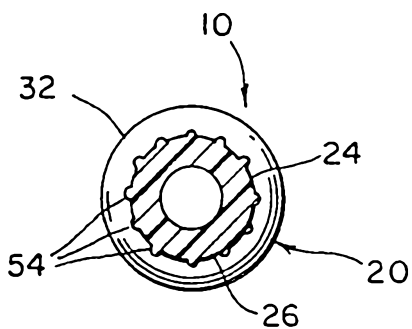

FIG. 3

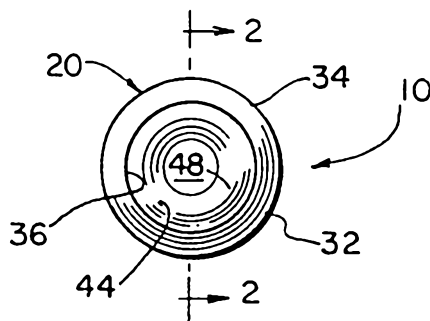

FIG. 4

FIG. 5

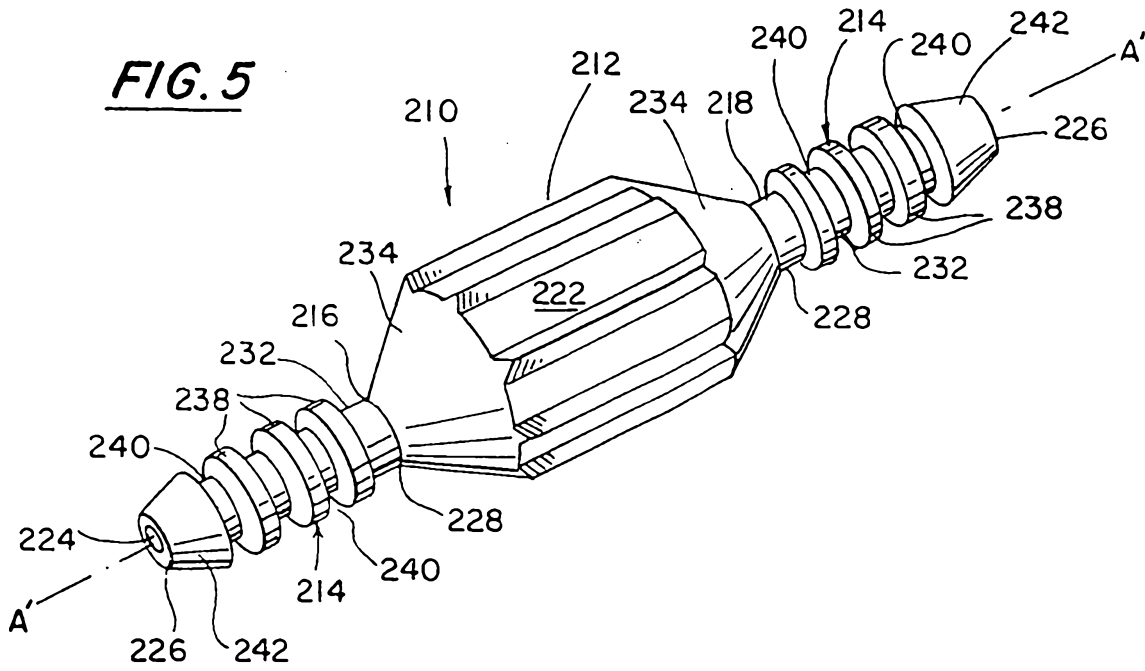

FIG. 9

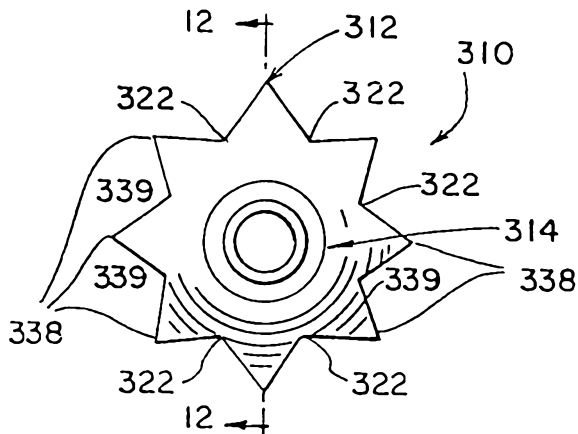
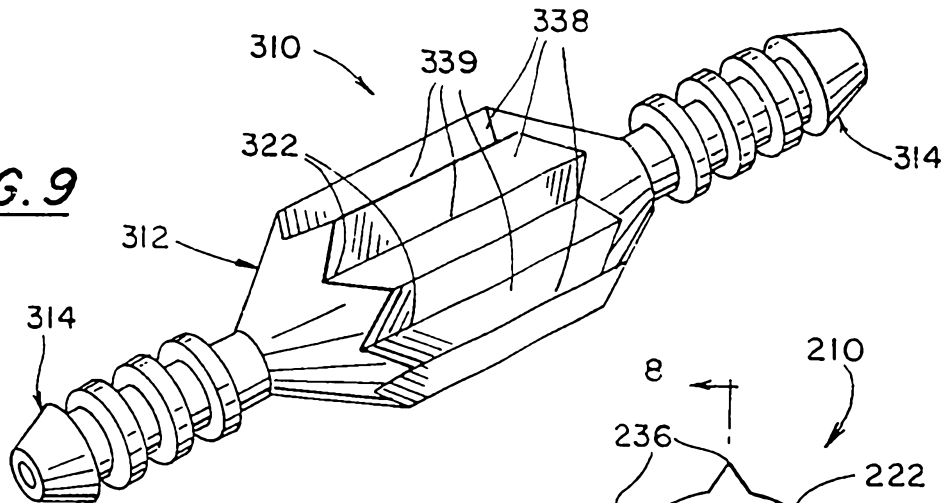

FIG. 11

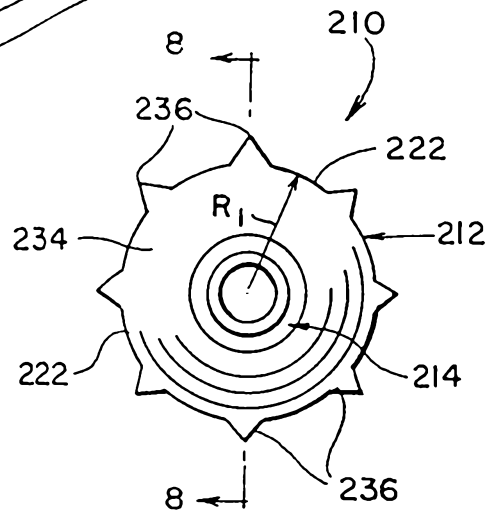

FIG. 7

30 04 98 63738

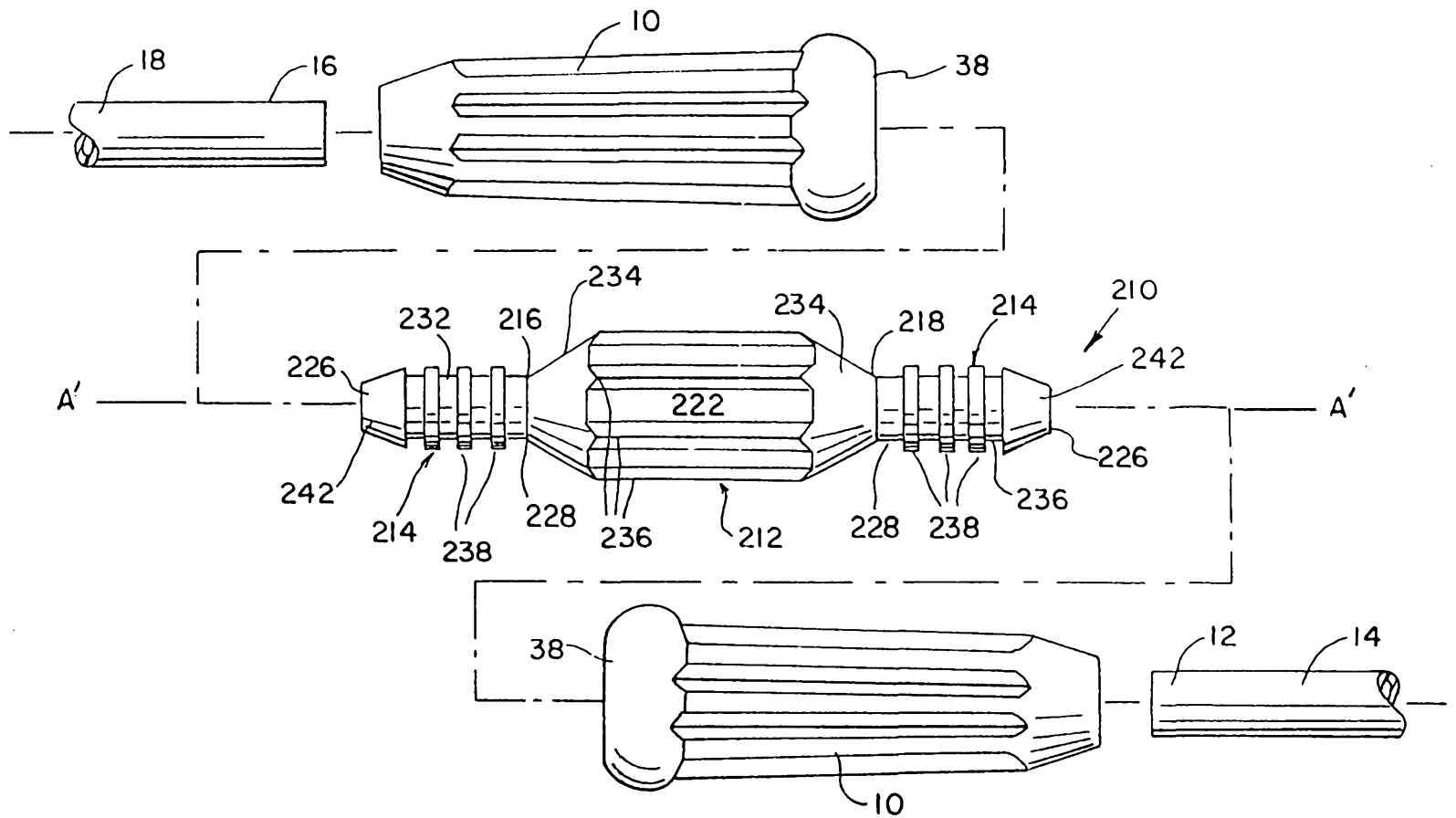

FIG. 6

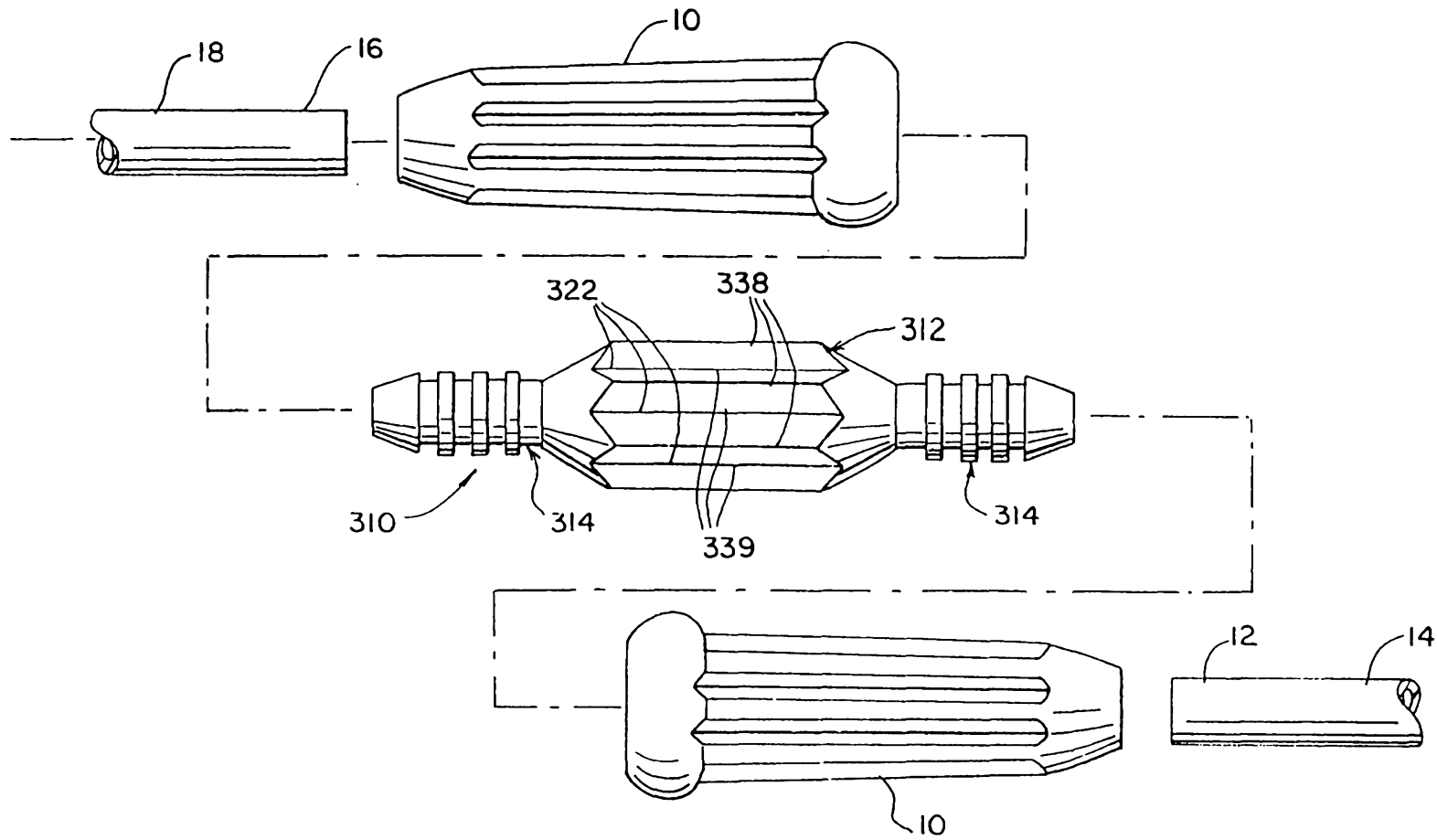

FIG. 10

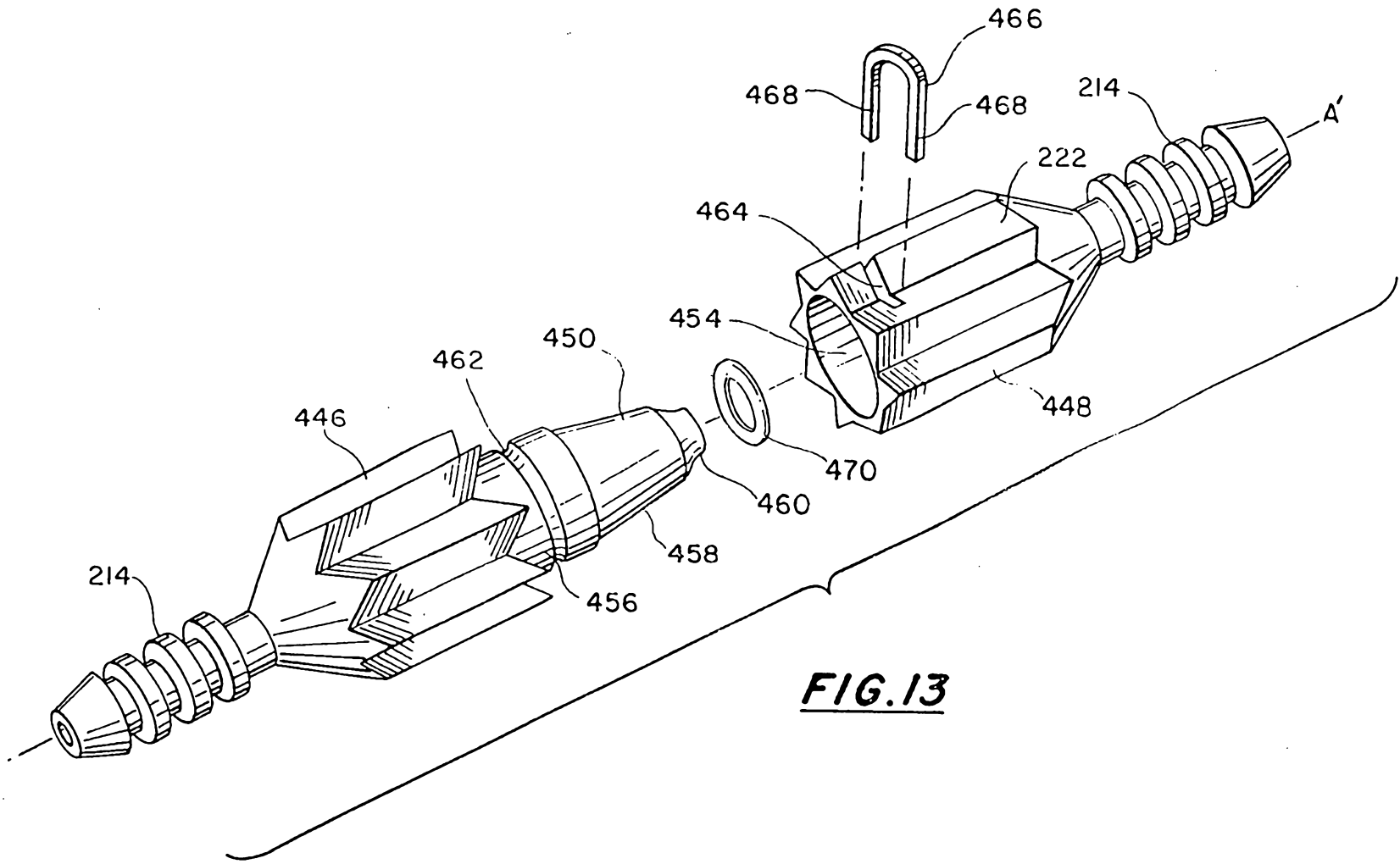

FIG.13

30 04 00 03730

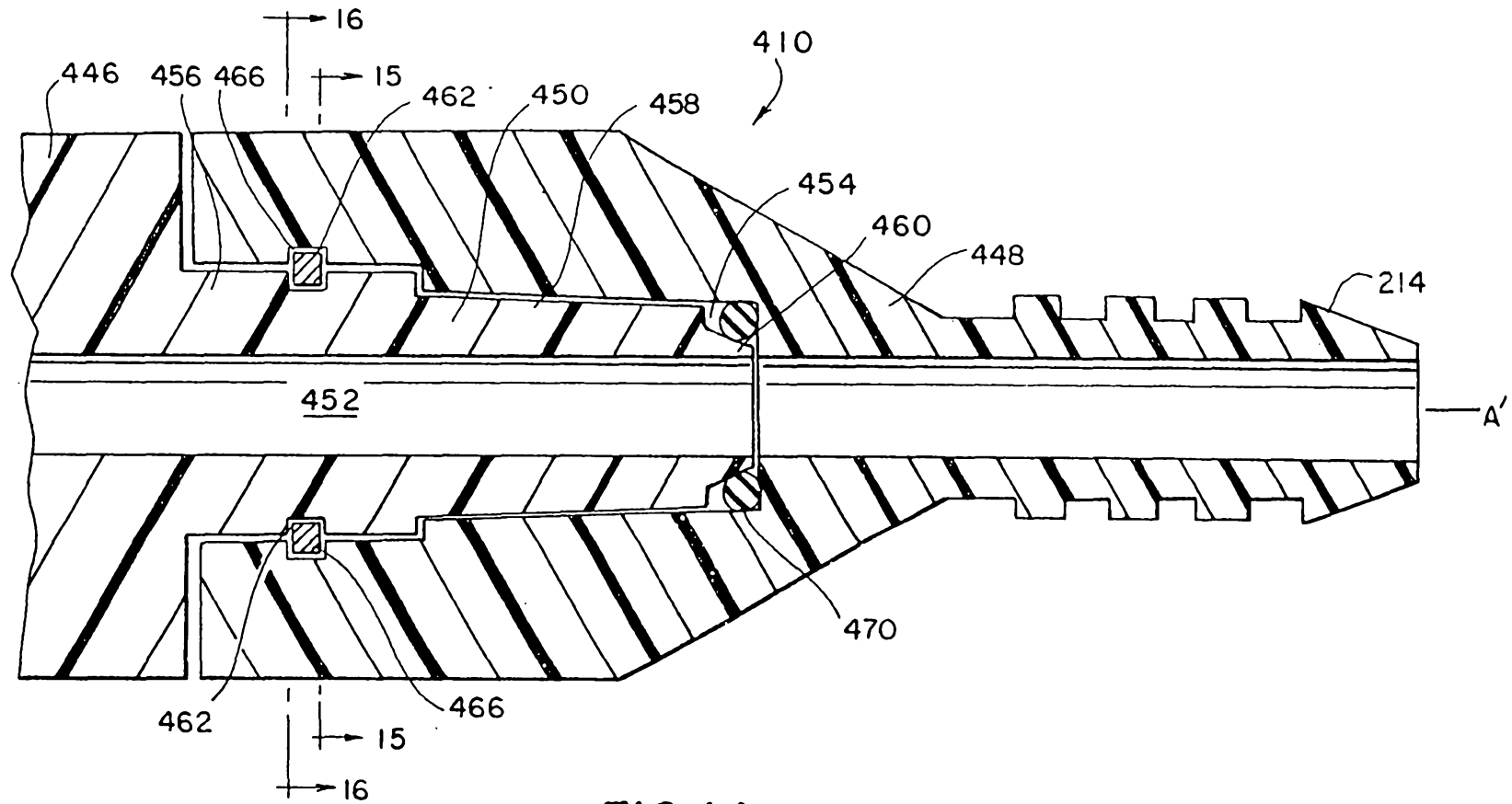

FIG. 14

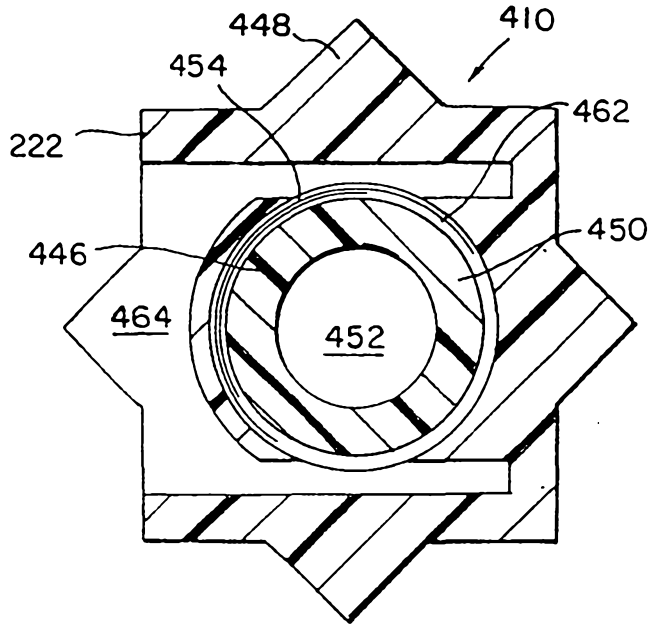

FIG. 15

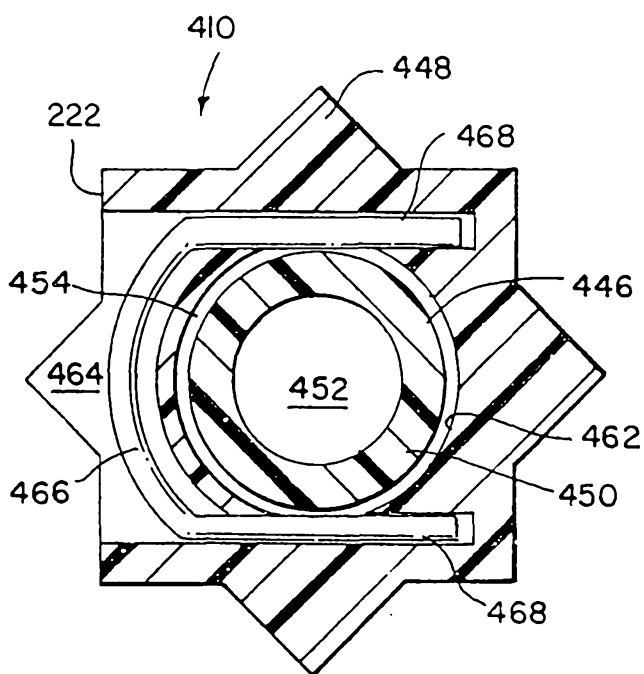

FIG. 16

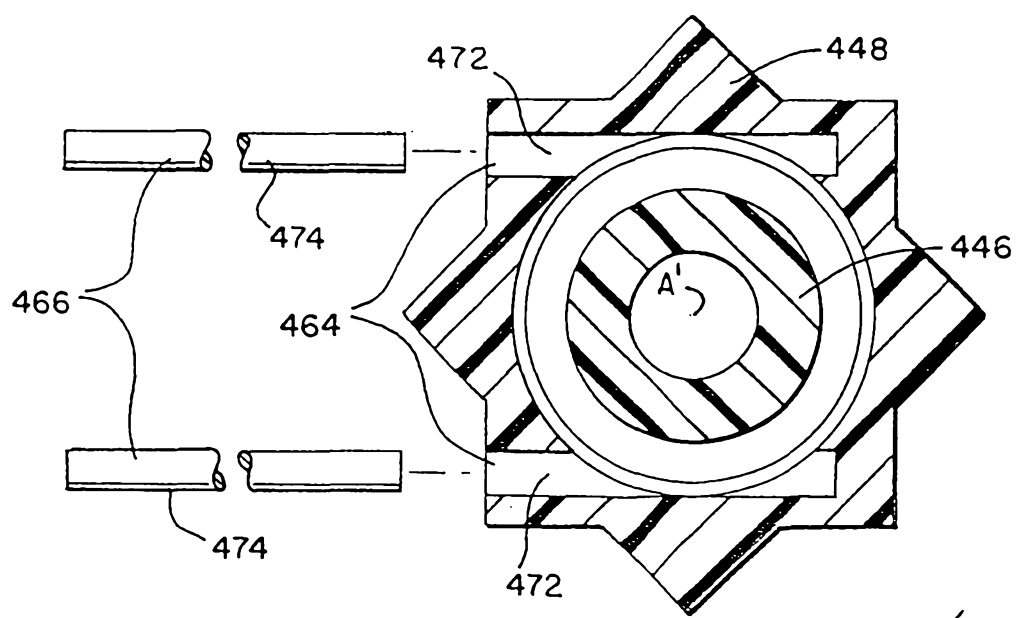

FIG. 17

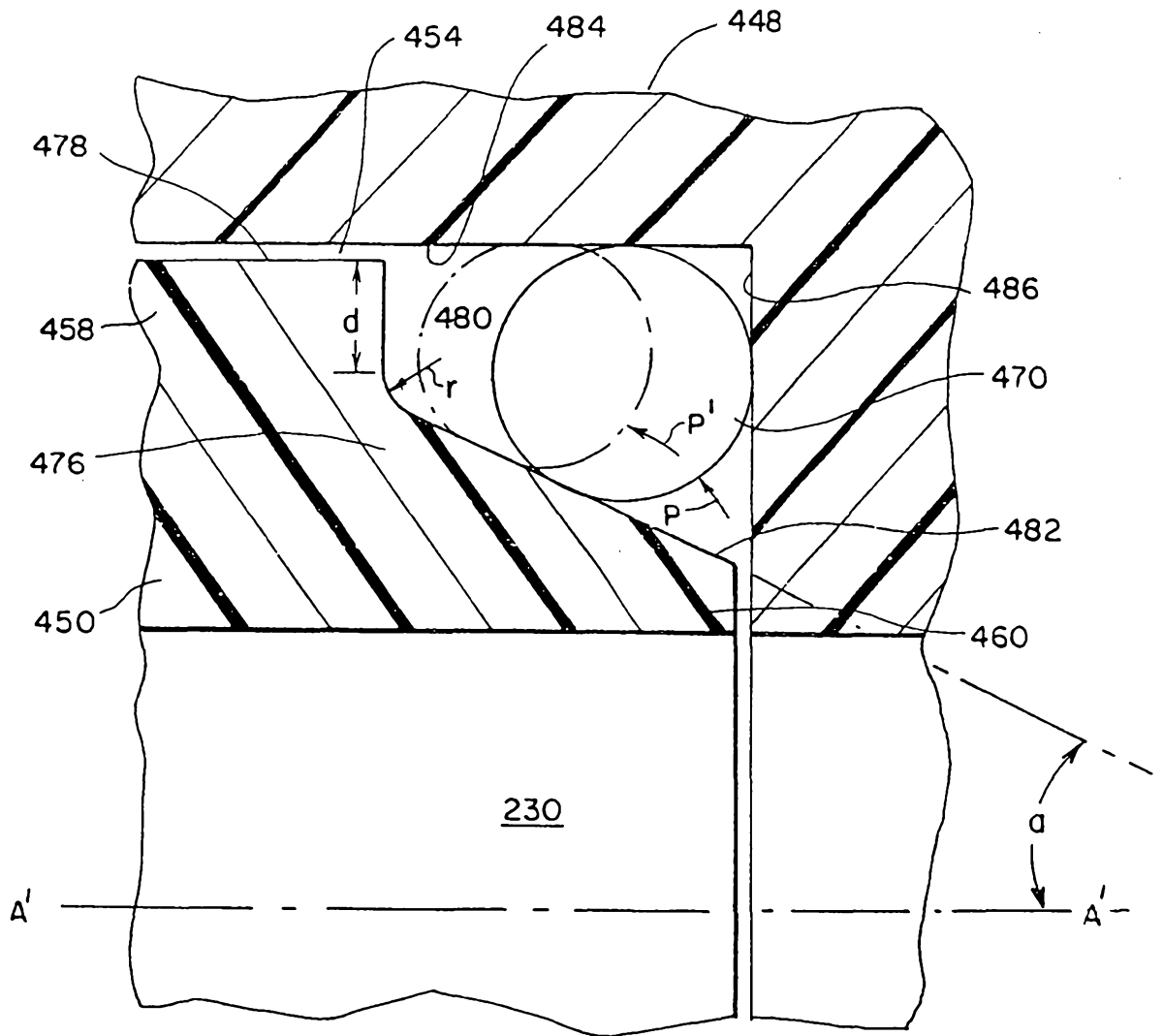

FIG. 18

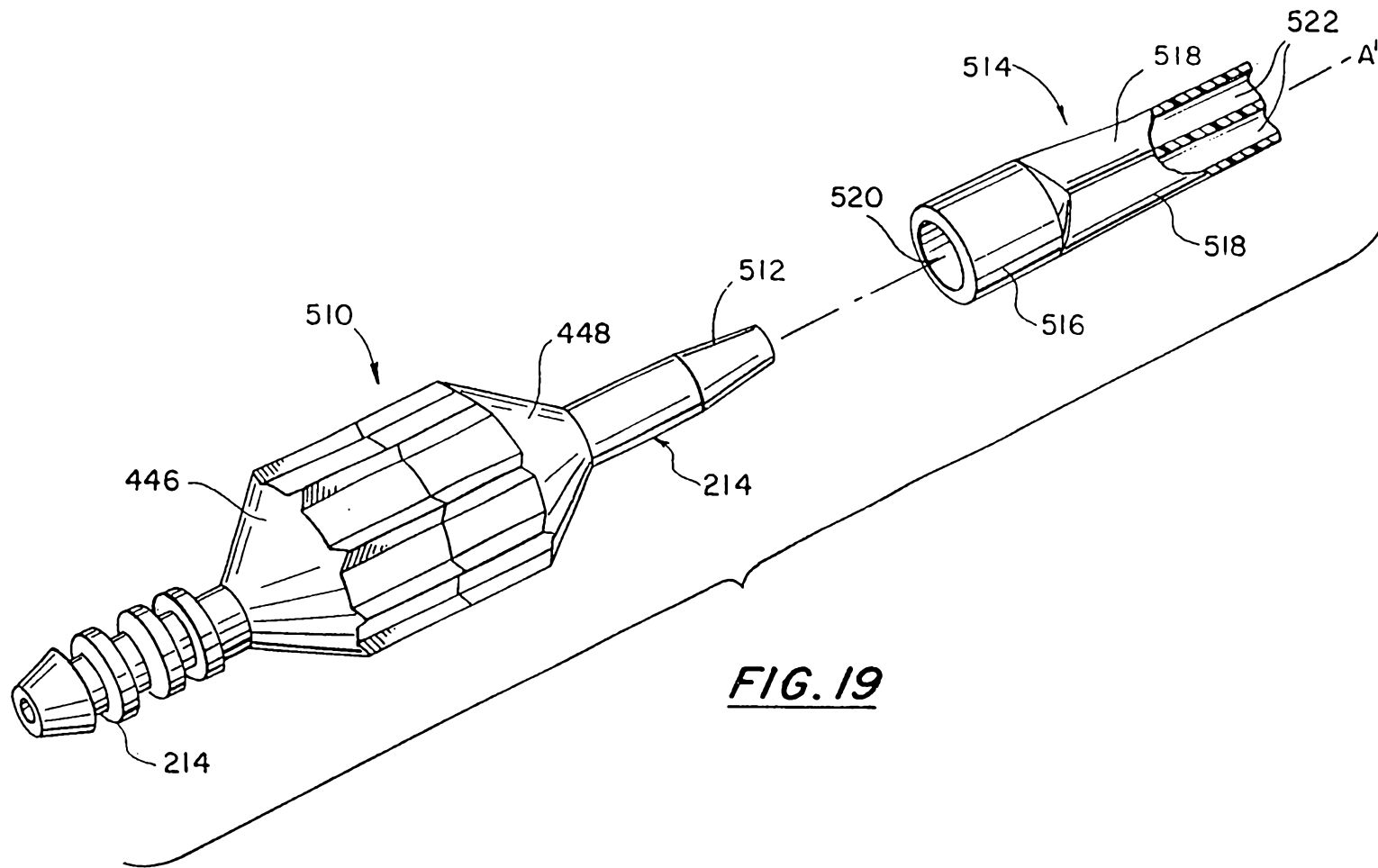

FIG. 19

30 04 90 0738

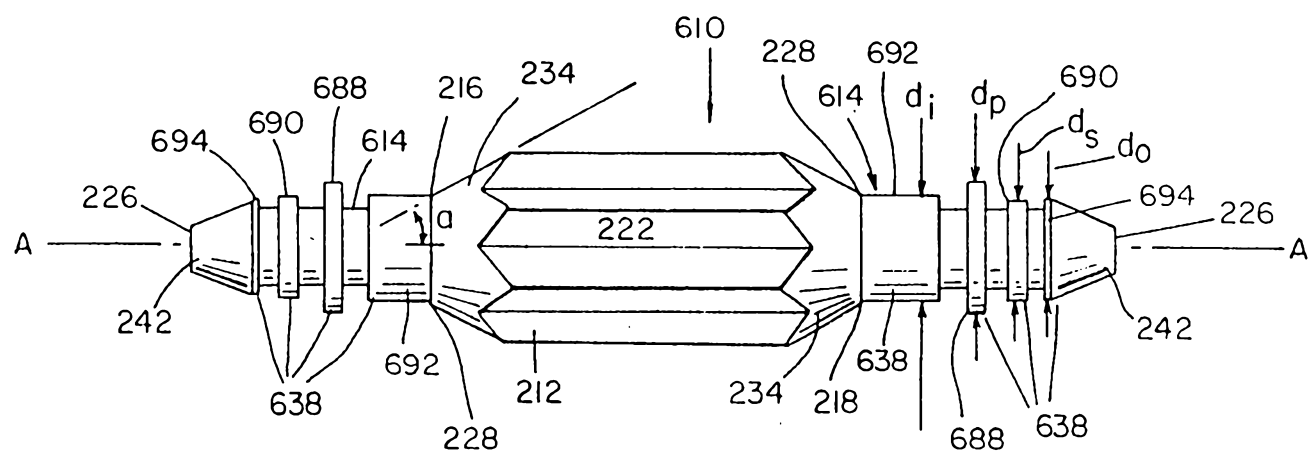

FIG. 20

30 04 00 0738

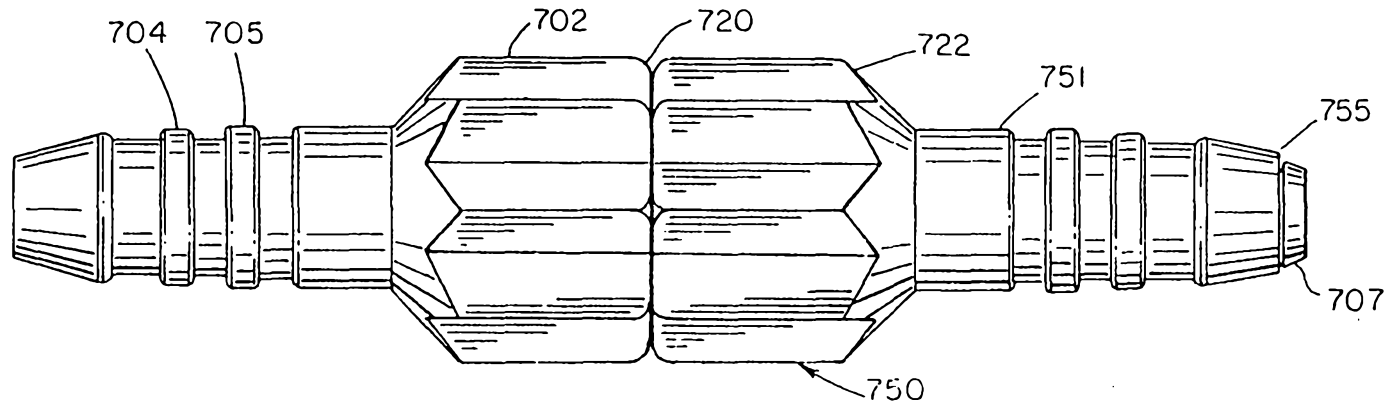

FIG. 21

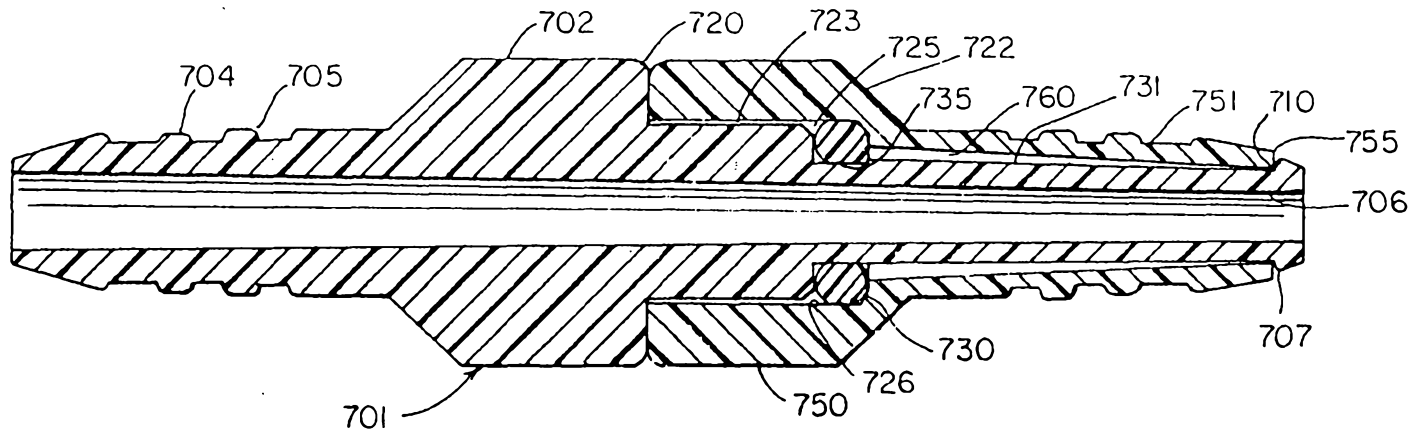

FIG. 22