

(19) World Intellectual Property Organization
International Bureau



(43) International Publication Date
13 November 2008 (13.11.2008)

PCT

(10) International Publication Number
WO 2008/137898 A1

(51) International Patent Classification:

B22D 11/06 (2006.01) **B22D 11/124** (2006.01)
C22C 27/02 (2006.01)

(21) International Application Number:

PCT/US2008/062776

(22) International Filing Date: 6 May 2008 (06.05.2008)

(25) Filing Language: English

(26) Publication Language: English

(30) Priority Data:

11/744,881 6 May 2007 (06.05.2007) US
60/943,781 13 June 2007 (13.06.2007) US

(63) Related by continuation (CON) or continuation-in-part (CIP) to earlier application:

US 11/744,881 (CIP)
Filed on 6 May 2007 (06.05.2007)

(71) Applicant (for AE, AG, AL, AM, AO, AT, AZ, BA, BB, BE, BF, BG, BH, BJ, BR, BW, BY, BZ, CA, CF, CG, CH, CI, CM, CN, CO, CR, CU, CY, CZ, DE, DK, DM, DO, DZ, EC, EE, EG, ES, FI, FR, GA, GB, GD, GE, GH, GM, GN, GQ, GR, GT, GW, HN, HR, HU, IE, IL, IN, IS, IT, JP, KE, KG, KM, KN, KP, KR, KZ, LA, LC, LK, LR, LS, LT, LU, LV, LY, MA, MC, MD, ME, MG, MK, ML, MN, MR, MT, MW, MX, MZ, NA, NE, NG, NI, NL, NO, OM, PG, PL only): **NUCOR**

CORPORATION [US/US]; 1915 Rexford Road, Charlotte, North Carolina 28211 (US).

(71) Applicants (for AU, ID, MY, NZ, PH, SG, VN only): **BLUESCOPE STEEL LIMITED** [AU/AU]; Level 11, 120 Collins Street, Melbourne, Victoria 3000 (AU). **IHI CORPORATION** [JP/JP]; 1-1 Toyosu 3-chome, Koto-ku, Tokyo 135-8710 (JP).

(72) Inventors; and

(75) Inventors/Applicants (for US only): **WILLIAMS, James Geoffery** [AU/AU]; 8 Blanchard Crescent, Balgownie, New South Wales 2519 (AU). **KAUL, Harold Roland** [AU/AU]; 11 Gowan Brae Drive, Mt. Ousley, New South Wales 2519 (AU). **EDELMAN, Daniel Geoffrey** [US/US]; 632 South School Street, Brownsburg, Indiana 46112 (US). **KILLMORE, Christopher Ronald** [AU/AU]; 32/59-67 Corrimal Street, Wollongong, New South Wales 2500 (AU).

(74) Agent: **MUNT, Greg**; Griffith Hack, 509 St Kilda Road, Melbourne, Victoria 3004 (AU).

(81) Designated States (unless otherwise indicated, for every kind of national protection available): AE, AG, AL, AM, AO, AT, AU, AZ, BA, BB, BG, BH, BR, BW, BY, BZ, CA, CH, CN, CO, CR, CU, CZ, DE, DK, DM, DO, DZ, EC, EE, EG, ES, FI, GB, GD, GE, GH, GM, GT, HN, HR, HU, ID, IL, IN, IS, JP, KE, KG, KM, KN, KP, KR, KZ, LA, LC,

[Continued on next page]

(54) Title: A THIN CAST STRIP PRODUCT WITH MICROALLOY ADDITIONS, AND METHOD FOR MAKING THE SAME

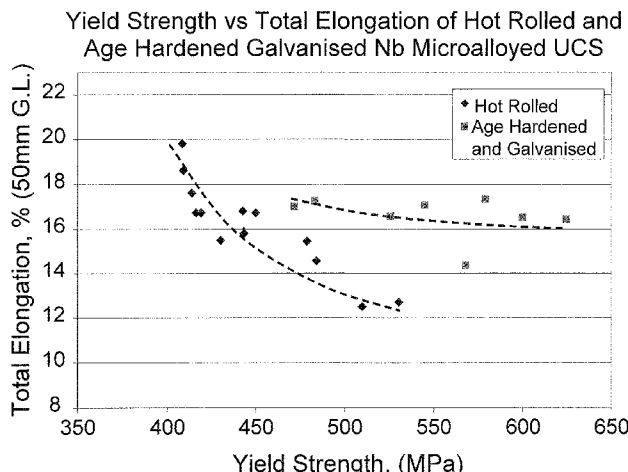

Fig. 19

(57) Abstract: A steel product or thin steel cast strip comprised of, by weight, less than 0.25% carbon, between 0.20 and 2.0% manganese, between 0.05 and 0.50% silicon, less than 0.01% aluminum, and at least one of niobium between 0.01% and 0.20% and vanadium between 0.01% and 0.20%, and having a microstructure of a majority bainite and acicular ferrite, and more than 70% niobium and/or vanadium in solid solution. The steel product may have an increase in elongation and an increase in yield strength after age hardening. The age hardened steel product may have niobium carbonitride particles with an average particle size of 10 nanometers and less, and may have substantially no niobium carbonitride particles greater than 50 nanometers. The steel product may have a yield strength of at least 380 MPa or a tensile strength of at least 410 MPa, or both. The steel product or thin cast steel strip may have a total elongation of at least 6% or 10%.

WO 2008/137898 A1



LK, LR, LS, LT, LU, LY, MA, MD, ME, MG, MK, MN, MW, MX, MY, MZ, NA, NG, NI, NO, NZ, OM, PG, PH, PL, PT, RO, RS, RU, SC, SD, SE, SG, SK, SL, SM, SV, SY, TJ, TM, TN, TR, TT, TZ, UA, UG, US (patent), UZ, VC, VN, ZA, ZM, ZW.

European (AT, BE, BG, CH, CY, CZ, DE, DK, EE, ES, FI, FR, GB, GR, HR, HU, IE, IS, IT, LT, LU, LV, MC, MT, NL, NO, PL, PT, RO, SE, SI, SK, TR), OAPI (BF, BJ, CF, CG, CI, CM, GA, GN, GQ, GW, ML, MR, NE, SN, TD, TG).

(84) Designated States (*unless otherwise indicated, for every kind of regional protection available*): ARIPO (BW, GH, GM, KE, LS, MW, MZ, NA, SD, SL, SZ, TZ, UG, ZM, ZW), Eurasian (AM, AZ, BY, KG, KZ, MD, RU, TJ, TM),

Published:

- *with international search report*
- *before the expiration of the time limit for amending the claims and to be republished in the event of receipt of amendments*

**A THIN CAST STRIP PRODUCT WITH MICROALLOY
ADDITIONS, AND METHOD FOR MAKING THE SAME**

RELATED APPLICATIONS

[0001] This PCT application claims priority to United States Patent Application Serial No. 11/744,881, filed May 6, 2007, which is a continuation-in-part of application Serial No. 11/255,604, filed October 20, 2005. This application also claims priority to United States Provisional Patent Application Serial No. 60/943,781, filed June 13, 2007.

BACKGROUND AND SUMMARY

[0002] This invention relates to making of high strength thin cast strip, and the method for making such cast strip by a twin roll caster.

[0003] In a twin roll caster, molten metal is introduced between a pair of counter-rotated, internally cooled casting rolls so that metal shells solidify on the moving roll surfaces, and are brought together at the nip between them to produce a solidified strip product, delivered downwardly from the nip between the casting rolls. The term "nip" is used herein to refer to the general region at which the casting rolls are closest together. The molten metal is poured from a ladle through a metal delivery system comprised of a tundish and a core nozzle located above the nip to form a casting pool of molten metal, supported on the casting surfaces of the rolls above the nip and extending along the length of the nip. This casting pool is usually confined between refractory side plates or dams held in sliding engagement with the end surfaces of the rolls so as to dam the two ends of the casting pool against outflow.

[0004] In the past, high-strength low-carbon thin strip with yield strengths of 413 MPa (60 ksi) and higher, in strip thicknesses less than 3.0 mm, have been made by recovery annealing of cold rolled strip. Cold rolling was required to produce the desired thickness. The cold roll strip was then recovery annealed to improve the ductility without significantly reducing the strength. However, the final ductility of the resulting strip still was relatively low and the strip would not achieve total elongation levels over 6%, which is required for structural steels by some building codes for structural components. Such recovery annealed cold rolled, low-carbon steel was generally suitable only for simple forming operations, e.g.,

roll forming and bending. To produce this steel strip with higher ductility was not technically feasible in these final strip thicknesses using the cold rolled and recovery annealed manufacturing route.

[0005] In the past, high strength, steel has been made by microalloying with elements such as niobium, vanadium, titanium or molybdenum, and hot rolling to achieve the desired thickness and strength level. Such microalloying required expensive and high levels of niobium, vanadium, titanium or molybdenum and resulted in formation of a bainite-ferrite microstructure typically with 10 to 20% bainite. See U.S. Patent No. 6,488,790. Alternately, the microstructure could be ferrite with 10-20% pearlite. Hot rolling the strip resulted in the partial precipitation of these alloying elements. As a result, relatively high alloying levels of the Nb, V, Ti or Mo elements were required to provide enough age hardening of the predominately ferritic transformed microstructure to achieve the required strength levels. These high microalloying levels significantly raised the hot rolling loads needed and restricted the thickness range of the hot rolled strip that could be economically and practically produced. Such alloyed high strength strip could be directly used for galvanizing after pickling for the thicker end of the product range greater than 3 mm in thickness.

[0006] However, making of high strength, steel strip less than 3 mm in thickness with additions of Nb, V, Ti or Mo to the base steel chemistry was very difficult, particularly for wide strip due to the high rolling loads, and not always commercially feasible. In the past, large additions of these elements were needed for strengthening the steel, and in addition, caused reductions in elongation properties of the steel. High strength microalloyed hot rolled strips in the past were relatively inefficient in providing strength, relatively expensive, and often required compensating additions of other alloying elements.

[0007] Additionally, cold rolling was generally required for lower thicknesses of strip; however, the high strength of the hot rolled strip made such cold rolling difficult because of the high cold roll loadings required to reduce the thickness of the strip. These high alloying levels also considerably raised the recrystallization annealing temperature needed, requiring expensive to build and operate annealing lines capable of achieving the high annealing temperature needed for full recrystallization annealing of the cold rolled strip.

[0008] In short, the application of previously known microalloying practices with Nb, V, Ti or Mo elements to produce high strength thin strip could not be commercially produced economically because of the high alloying costs, relative inefficiency of element additions,

difficulties with high rolling loads in hot rolling and cold rolling, and the high recrystallization annealing temperatures required.

[0009] A steel product is disclosed comprising, by weight, less than 0.25% carbon, between 0.20 and 2.0% manganese, between 0.05 and 0.50% silicon, less than 0.01% aluminum, and niobium between about 0.01% and about 0.20% and having a majority of the microstructure comprised of bainite and acicular ferrite and having more than 70% niobium in solid solution. Alternately, the niobium may be less than 0.1%. The steel product may further comprise at least one element selected from the group consisting of molybdenum between about 0.05% and about 0.50%, vanadium between about 0.01% and about 0.20%, and a mixture thereof.

[0010] The steel product may have a yield strength of at least 340 MPa, and may have a tensile strength of at least 410 MPa. The steel product may have a yield strength of at least 485 MPa and a tensile strength of at least of at least 520 MPa. The steel product has a total elongation of at least 6%. Alternately, the total elongation may be at least 10%.

[0011] The steel product may be a thin cast steel strip. Optionally, the thin cast steel strip may have fine oxide particles of silicon and iron distributed through the steel microstructure having an average particle size less than 50 nanometers

[0012] The thin cast steel strip may have a thickness of less than 2.5 mm. Alternately, the thin cast steel strip may have a thickness of less than 2.0 mm. In yet another alternative, the thin cast steel strip may have a thickness in the range from about 0.5 mm to about 2 mm.

[0013] The hot rolled steel product of less than 3 millimeters thickness is also disclosed comprised, by weight, of less than 0.25% carbon, between 0.20 and 2.0% manganese, between 0.05% and 0.50% silicon, less than 0.01% aluminum, and niobium between about 0.01% and about 0.20%, and have a majority of the microstructure comprised of bainite and acicular ferrite and capable of providing a yield strength of at least 410 MPa with a reduction of between 20% and 40%. The steel product may have a yield strength of at least 485 MPa and a tensile strength of at least of at least 520 MPa. Alternately, the niobium may be less than 0.1%.

[0014] Optionally, the hot rolled steel product may have fine oxide particles of silicon and iron distributed through the steel microstructure having an average particle size less than 50 nanometers.

[0015] The hot rolled steel product has a total elongation of at least 6%. Alternately, the total elongation may be at least 10%. The hot rolled steel product may have a thickness of less than 2.5 mm. Alternately, the hot rolled steel product may have a thickness of less than 2.0 mm. In yet another alternative, the hot rolled steel product may have a thickness in the range from about 0.5 mm to about 2 mm.

[0016] Also disclosed is a coiled steel product comprised, by weight, of less than 0.25% carbon, between 0.20 and 2.0% manganese, between 0.05 and 0.50% silicon, less than 0.01% aluminum, and at least one element selected from the group consisting of niobium between about 0.01% and about 0.20%, vanadium between about 0.01% and about 0.20%, and a mixture thereof, and having more than 70% niobium and/or vanadium in solid solution after coiling and cooling. Alternately, the niobium may be less than 0.1%.

[0017] Optionally, the coiled steel product may have fine oxide particles of silicon and iron distributed through the steel microstructure having an average particle size less than 50 nanometers.

[0018] The coiled steel product may have a yield strength of at least 340 MPa, and may have a tensile strength of at least 410 MPa. The coiled steel product has a thickness of less than 3.0 mm. The steel product may have a yield strength of at least 485 MPa and a tensile strength of at least of at least 520 MPa.

[0019] Alternately, the coiled steel product has a thickness of less than 2.5 mm. Alternately, the coiled steel product may have a thickness of less than 2.0 mm. In yet another alternative, the coiled steel product may have a thickness in the range from about 0.5 mm to about 2 mm. The coiled steel product has a total elongation of at least 6%. Alternately, the total elongation may be at least 10%.

[0020] An age hardened steel product is also disclosed comprising, by weight, less than 0.25% carbon, between 0.20 and 2.0% manganese, between 0.05 and 0.50% silicon, less than 0.01% aluminum, at least one element from the group consisting of niobium between about 0.01% and about 0.20%, vanadium between about 0.01% and about 0.20%, and a mixture thereof, and having a majority of the microstructure comprised of bainite and acicular ferrite and having an increase in elongation and an increase in yield strength after age hardening. Alternately, the niobium may be less than 0.1%.

[0021] The age hardened steel product may comprise, in addition, fine oxide particles of silicon and iron distributed through the steel microstructure having an average particle size less than 50 nanometers.

[0022] The steel product may have a yield strength of at least 340 MPa, or at least 380 MPa, or at least 410 MPa, or at least 450 MPa, or at least 500 MPa, or at least 550 MPa, or at least 600 MPa, or at least 650 MPa, as desired. The steel product may have a tensile strength of at least 410 MPa, or at least 450 MPa, or at least 500 MPa, or at least 550 MPa, or at least 600 MPa, or at least 650 MPa, or at least 700 MPa, as desired. The age hardened steel product has a thickness of less than 3.0 mm. Alternately, the age hardened steel product has a thickness of less than 2.5 mm. Alternately, the age hardened steel product may have a thickness of less than 2.0 mm. In yet another alternative, the age hardened steel product may have a thickness in the range from about 0.5 mm to about 2 mm. The age hardened steel product has a total elongation of at least 6%. Alternately, the total elongation may be at least 10%.

[0023] A steel product comprising, by weight, less than 0.25% carbon, between 0.20 and 2.0% manganese, between 0.05 and 0.50% silicon, less than 0.01% aluminum, and at least one element selected from the group consisting of niobium between about 0.01% and about 0.20% and vanadium between about 0.01% and about 0.20%, and having a majority of the microstructure comprised of bainite and acicular ferrite and comprising fine oxide particles of silicon and iron distributed through the steel microstructure having an average particle size less than 50 nanometers. Alternately, the niobium may be less than 0.1%. Optionally, the steel product may comprise molybdenum between about 0.05% and 0.50%.

[0024] The steel product may have a yield strength of at least 340 MPa, and may have a tensile strength of at least 410 MPa. The steel product may have a yield strength of at least 485 MPa and a tensile strength of at least of at least 520 MPa. The steel product has a total elongation of at least 6%. Alternately, the total elongation may be at least 10%.

[0025] An age hardened steel product comprising, by weight, less than 0.25% carbon, between 0.20 and 2.0% manganese, between 0.05 and 0.50% silicon, less than 0.01% aluminum, and niobium between about 0.01% and about 0.20%, and having a majority of the microstructure comprised of bainite and acicular ferrite and having niobium carbonitride particles with an average particle size of less than 10 nanometers. Carbonitride particles, in

the present specification and appended claims, includes carbides, nitrides, carbonitrides, and combinations thereof. Alternately, the niobium may be less than 0.1%.

[0026] The age hardened steel product may have substantially no niobium carbonitride particles greater than 50 nanometers. The age hardened steel product may have a yield strength of at least 340 MPa, and may have a tensile strength of at least 410 MPa. The age hardened steel product has a total elongation of at least 6%. Alternately, the total elongation may be at least 10%.

[0027] A method is disclosed for preparing coiled thin cast steel strip comprising the steps of:

assembling internally a cooled roll caster having laterally positioned casting rolls forming a nip between them, and forming a casting pool of molten steel supported on the casting rolls above the nip and confined adjacent the ends of the casting rolls by side dams,

counter rotating the casting rolls to solidify metal shells on the casting rolls as the casting rolls move through the casting pool, and

forming from the metal shells downwardly through the nip between the casting rolls a steel strip, and

cooling the steel strip at a rate of at least 10 °C per second to provide a composition comprising by weight, less than 0.25% carbon, between 0.20 and 2.0% manganese, between 0.05 and 0.50% silicon, less than 0.01% aluminum, and at least one element selected from the group consisting of niobium between about 0.01% and about 0.20%, vanadium between about 0.01% and about 0.20%, and a mixture thereof, and having a majority of the microstructure comprised of bainite and acicular ferrite and having more than 70% niobium and/or vanadium in solid solution.

[0028] The method may provide in the steel strip as coiled fine oxide particles of silicon and iron distributed through the steel microstructure having an average particle size less than 50 nanometers. Further, the method may comprise the steps of hot rolling the steel strip, and coiling the hot rolled steel strip at a temperature between about 450 and 700 °C. Alternately, the coiling of the hot rolled steel strip may be at a temperature less than 650 °C.

[0029] The method may further comprise the step of age hardening the steel strip to increase the tensile strength at a temperature of at least 550 °C. Alternately, the age hardening

may occur at a temperature between 625 °C and 800 °C. In yet another alternate, the age hardening may occur at a temperature between 650 °C and 750 °C.

[0030] Also disclosed is a method of preparing a thin cast steel strip comprised the steps of:

assembling internally a cooled roll caster having laterally positioned casting rolls forming a nip between them, and forming a casting pool of molten steel supported on the casting rolls above the nip and confined adjacent the ends of the casting rolls by side dams,

counter rotating the casting rolls to solidify metal shells on the casting rolls as the casting rolls move through the casting pool, and

forming steel strip from the metal shells cast downwardly through the nip between the casting rolls, and

cooling the steel strip at a rate of at least 10 °C per second to provide a composition comprising by weight, less than 0.25% carbon, less than 0.01% aluminum, and at least one element from the group consisting of niobium between about 0.01% and about 0.20%, vanadium between about 0.01% and about 0.20%, and a mixture thereof, and having a majority of the microstructure comprised of bainite and acicular ferrite and having more than 70% niobium and/or vanadium in solid solution,

age hardening the steel strip at a temperature between 625 °C and 800 °C.

[0031] The method may further comprise the step of age hardening the steel strip to increase the tensile strength. Alternately, the age hardening may occur at a temperature between 650 °C and 750 °C.

[0032] The method may provide the age hardened steel strip having niobium carbonitride particles with an average particle size of less than 10 nanometers. Alternately, the age hardened steel strip has substantially no niobium carbonitride particles greater than 50 nanometers.

[0033] The method may provide in the steel strip as coiled fine oxide particles of silicon and iron distributed through the steel microstructure having an average particle size less than 50 nanometers. Further, the method may comprise the steps of hot rolling the steel strip, and coiling the hot rolled steel strip at a temperature less than 700 °C. Alternately, the coiling of the hot rolled steel strip may be at a temperature less than 650 °C.

[0034] The method of preparing a thin cast steel strip may comprise the steps of:
assembling internally a cooled roll caster having laterally positioned casting rolls forming a nip between them, and forming a casting pool of molten steel supported on the casting rolls above the nip and confined adjacent the ends of the casting rolls by side dams,
counter rotating the casting rolls to solidify metal shells on the casting rolls as the casting rolls move through the casting pool; and
forming from the metal shells downwardly through the nip between the casting rolls a steel strip; and
cooling the steel strip at a rate of at least 10 °C per second to provide a composition comprising by weight, less than 0.25% carbon, between 0.20 and 2.0% manganese, between 0.05 and 0.50% silicon, less than 0.01% aluminum, and at least one element from the group consisting of niobium between about 0.01% and about 0.20%, vanadium between about 0.01% and about 0.20%, and a mixture thereof, and having a majority of the microstructure comprised of bainite and acicular ferrite,
age hardening the steel strip at a temperature between 625° C and 800 °C and having an increase in elongation and an increase in yield strength after age hardening.

[0035] The method may provide in the steel strip as coiled fine oxide particles of silicon and iron distributed through the steel microstructure having an average particle size less than 50 nanometers. Further, the method may provide the age hardened steel strip having niobium carbonitride particles with an average particle size of less than 10 nanometers. Alternately, the age hardened steel strip has substantially no niobium carbonitride particles greater than 50 nanometers.

[0036] The method may comprise the steps of hot rolling the steel strip, and coiling the hot rolled steel strip at a temperature less than 750 °C. Alternately, the coiling of the hot rolled steel strip may be at a temperature less than 700 °C.

BRIEF DESCRIPTION OF THE DRAWINGS

[0037] In order that the invention may be described in more detail, some illustrative examples will be given with reference to the accompanying drawings in which:

- [0038] FIG. 1 illustrates a strip casting installation incorporating an in-line hot rolling mill and coiler;
- [0039] FIG. 2 illustrates details of the twin roll strip caster;
- [0040] FIG. 3 illustrates the effect of coiling temperature on strip yield strength with and without niobium or vanadium additions;
- [0041] FIG. 4a is an optical micrograph of a niobium steel strip;
- [0042] FIG. 4b is an optical micrograph of a standard UCS SS Grade 380 steel strip;
- [0043] FIG. 5 is graph showing the effect of post coil age hardening on yield strength of the present steel strip;
- [0044] FIG. 6 is a graph showing the effect of post coiling simulated age hardening cycle on yield and tensile strength of the present steel strip,
- [0045] FIG. 7 is a graph showing the effect of hot rolling reduction on the yield strength; and
- [0046] FIG. 8 is a graph showing the effect of yield strength on elongation;
- [0047] FIG. 9 is a graph showing the effect of niobium amount on the yield strength at low levels of niobium;
- [0048] FIG. 10a shows micrographs of the microstructure of a first sample of 0.065% niobium steel after hot rolling;
- [0049] FIG. 10b shows micrographs of the microstructure of a second sample of 0.065% niobium steel after hot rolling;
- [0050] FIG. 11 is a graph showing the effect of niobium amount on the yield strength;
- [0051] FIG. 12 is a graph showing the effect of coiling temperature on the yield strength;
- [0052] FIG. 13 is a graph showing the effect of coiling temperature on the yield strength at low niobium levels;
- [0053] FIG. 14 is a graph showing the effect of heat treating conditions on the yield strength;
- [0054] FIG. 15 is a graph showing the effect of age hardening heat treating temperature on the yield strength of 0.026% niobium steel;

- [0055] FIG. 16 is a graph showing the effect of peak aging temperature on the yield strength of 0.065% niobium steel;
- [0056] FIG. 17 is a graph showing the effect of peak aging temperature and hold time on the yield strength of 0.065% niobium steel;
- [0057] FIG. 18 is a graph showing the effect of peak aging temperature and hold time on the yield strength for 0.084% niobium steel;
- [0058] FIG. 19 is a graph showing the effect of yield strength on elongation before and after age hardening;
- [0059] FIG. 20 is a graph showing heat treating results continuous annealing;
- [0060] FIG. 21 is a graph showing age hardened condition;
- [0061] FIG. 22 is a graph showing the effect of temperature and time on hardness;
- [0062] FIG. 23 is a graph showing the effect of heat treating on the yield strength for the present vanadium steel; and
- [0063] FIG. 24 is a graph showing the effect of hot rolling reduction on the yield strength for the present vanadium steel.

DETAILED DESCRIPTION OF THE DRAWINGS

[0064] The following description of the embodiments is in the context of high strength thin cast strip with microalloy additions made by continuous casting steel strip using a twin roll caster.

[0065] FIG. 1 illustrates successive parts of strip caster for continuously casting steel strip. FIGS. 1 and 2 illustrate a twin roll caster 11 that continuously produces a cast steel strip 12, which passes in a transit path 10 across a guide table 13 to a pinch roll stand 14 having pinch rolls 14A. Immediately after exiting the pinch roll stand 14, the strip passes into a hot rolling mill 16 having a pair of reduction rolls 16A and backing rolls 16B where the cast strip is hot rolled to reduce a desired thickness. The hot rolled strip passes onto a run-out table 17 where the strip may be cooled by convection and contact with water supplied via water jets 18 (or other suitable means) and by radiation. The rolled and cooled strip is then passes

through a pinch roll stand 20 comprising a pair of pinch rolls 20A and then to a coiler 19. Final cooling of the cast strip takes place after coiling.

[0066] As shown in FIG. 2, twin roll caster 11 comprises a main machine frame 21, which supports a pair of laterally positioned casting rolls 22 having casting surfaces 22A. Molten metal is supplied during a casting operation from a ladle (not shown) to a tundish 23, through a refractory shroud 24 to a distributor or moveable tundish 25, and then from the distributor 25 through a metal delivery nozzle 26 between the casting rolls 22 above the nip 27. The molten metal delivered between the casting rolls 22 forms a casting pool 30 above the nip. The casting pool 30 is restrained at the ends of the casting rolls by a pair of side closure dams or plates 28, which are pushed against the ends of the casting rolls by a pair of thrusters (not shown) including hydraulic cylinder units (not shown) connected to the side plate holders. The upper surface of casting pool 30 (generally referred to as the "meniscus" level) usually rises above the lower end of the delivery nozzle so that the lower end of the delivery nozzle is immersed within the casting pool 30. Casting rolls 22 are internally water cooled so that shells solidify on the moving roller surfaces as they pass through the casting pool, and are brought together at the nip 27 between them to produce the cast strip 12, which is delivered downwardly from the nip between the casting rolls.

[0067] The twin roll caster may be of the kind that is illustrated and described in some detail in U.S. Patent. Nos. 5,184,668 and 5,277,243 or U.S. Patent. No. 5,488,988. Reference may be made to those patents for appropriate construction details of a twin roll caster appropriate for use in an embodiment of the present invention.

[0068] A high strength thin cast strip product can be produced using the twin roll caster that overcomes the shortcomings of conventional light gauge steel products and produces a high strength, light gauge, steel strip product. The invention utilizes the elements including niobium (Nb), vanadium (V), titanium (Ti), or molybdenum (Mo), or a combination thereof.

[0069] Microalloying elements in steel are commonly taken to refer to the elements titanium niobium, and vanadium. These elements were usually added in the past in levels below 0.1%, but in some cases levels as high as 0.2%. These elements are capable of exerting strong effects on the steel microstructure and properties via a combination of hardenability, grain refining and strengthening effects (in the past as carbonitride formers). Molybdenum has not normally been regarded as a microalloying element since on its own it is a relatively

weak carbonitride former, but may be effective in the present circumstances and may form complex carbonitride particles along with niobium and vanadium. Carbonitride formation is inhibited in the hot rolled strip with these elements as explained below.

[0070] The high strength thin cast strip product combines several attributes to achieve a high strength light gauge cast strip product by microalloying with these elements. Strip thicknesses may be less than 3 mm, less than 2.5 mm, or less than 2.0 mm, and may be in a range of 0.5 mm to 2.0 mm. The cast strip is produced by hot rolling without the need for cold rolling to further reduce the strip to the desired thickness. Thus, the high strength thin cast strip product overlaps both the light gauge hot rolled thickness ranges and the cold rolled thickness ranges desired. The strip may be cooled at a rate of 10 °C per second and above, and still form a microstructure that is a majority and typically predominantly bainite and acicular ferrite.

[0071] The benefits achieved through the preparation of such a high strength thin cast strip product are in contrast to the production of previous conventionally produced microalloyed steels that result in relatively high alloy costs, inefficiencies in microalloying, difficulties in hot and cold rolling, and difficulties in recrystallization annealing since conventional continuous galvanizing and annealing lines are not capable of providing the high annealing temperatures needed. Moreover, the relatively poor ductility exhibited with strip made by the cold rolled and recovery annealed manufacturing route is overcome.

[0072] In previous conventionally produced microalloyed steels, elements such as niobium and vanadium could not remain in solid solution through solidification, hot rolling, coiling and cooling. The niobium and vanadium diffused through the microstructure forming carbonitride particles at various stages of the hot coil manufacturing process. Carbonitride particles, in the present specification and appended claims, includes carbides, nitrides, carbonitrides, and combinations thereof. The formation and growth of carbon and nitrogen particles in the hot slab and subsequent coiling of previous conventionally produced microalloyed steels further reduced the grain size of austenite in the hot slab, decreasing the hardenability of the steel. In these prior steels, the effect of particles in the hot slab had to be overcome by increasing the amount of microalloying elements, reheating the cast slabs to higher temperatures, and lowering carbon content.

[0073] In contrast to the previous conventionally produced steels, the present high strength thin cast steel strip product was produced comprising, by weight, less than 0.25%

carbon, between 0.20 and 2.00% manganese, between 0.05 and 0.50% silicon, less than 0.06% aluminum, and at least one element selected from the group consisting of titanium between about 0.01% and about 0.20%, niobium between about 0.01% and about 0.20%, molybdenum between about 0.05% and about 0.50%, and vanadium between about 0.01% and about 0.20%, and having a microstructure comprising a majority bainite. The steel product may further comprising fine oxide particles of silicon and iron distributed through the steel microstructure having an average particle size less than 50 nanometers. The steel product may further comprise a more even distribution of microalloys through the microstructure than previously produced with conventional slab cast product.

[0074] Alternately, the high strength thin cast steel strip product may comprise, by weight, less than 0.25% carbon, between 0.20 and 2.0% manganese, between 0.05 and 0.50% silicon, less than 0.01% aluminum, and niobium between about 0.01% and about 0.20%, and having a majority of the microstructure comprising bainite and acicular ferrite and having more than 70% soluble niobium.

[0075] In another alternate, a coiled steel product may comprise, by weight, less than 0.25% carbon, between 0.20 and 2.0% manganese, between 0.05 and 0.50% silicon, less than 0.01% aluminum, and at least one element selected from the group consisting of niobium between about 0.01% and about 0.20% and vanadium between about 0.01% and about 0.20%, and a combination thereof, and having more than 70% soluble niobium and vanadium, as selected, after coiling and cooling. The coiled high strength thin cast steel strip product may have more than 70% soluble niobium and vanadium, as selected, particularly after hot rolling reduction and subsequent coiling and before age hardening. The microstructure may be a mixture of bainite and acicular ferrite. Alternately, the microstructure of the hot rolled and subsequently coiled and cooled steel may comprise bainite and acicular ferrite with more than 80% niobium and/or vanadium remaining in solid solution, and alternately may have more than 90% remaining in solid solution.

[0076] Alternatively or in addition, the steel product may have a total elongation greater than 6% or greater than 10%. The steel product may have a yield strength of at least 340 MPa (about 49 ksi) or a tensile strength of at least 410 MPa, or both, exhibiting satisfactory ductility. The relationship between yield strength and total elongation in the hot rolled product is shown in FIG. 8.

[0077] After hot rolling the hot rolled steel strip may be coiled at a temperature in the range from about 500-700 °C. The thin cast steel strip may also be further processed by age hardening the steel strip to increase the tensile strength at a temperature of at least 550 °C. The age hardening may occur at a temperature between 550 °C and 800 °C, or between 625 °C and 750 °C, or between 675 °C and 750 °C. Conventional furnaces of continuous galvanizing or annealing lines are thus capable of providing the age hardening temperatures needed to harden the microalloyed cast strip product.

[0078] For example, a steel composition was prepared by making a steel composition of a 0.026% niobium, 0.04% by weight carbon, 0.85% by weight manganese, 0.25% by weight silicon that has been cast by a thin cast strip process. The strip was cast at 1.7 mm thick and inline hot rolled to a range of strip thickness from 1.5 mm to 1.1 mm using a twin roll caster as illustrated in FIGS. 1 and 2. The strip was coiled at coiling temperatures of 590-620 °C (1094-1148 °F).

[0079] As shown in FIG. 3, the yield and tensile strength levels achieved in the present cast strip are compared to the yield and tensile strength levels achievable in the base, non-microalloyed, cast strip steel composition over a range of coiling temperatures. It can be seen that the niobium steel strip achieved yield strengths in the range of 420-440 MPa (about 61-64 ksi) and tensile strengths of about 510 MPa (about 74 ksi). The present cast strip product is compared to C-Mn-Si base steel compositions processed with the same coiling temperature as the microalloyed steel, with the niobium steel producing substantially higher strength levels. The compared base steel strip had to be coiled at very low temperatures to approach comparable strength levels to the cast niobium steel product. The cast niobium steel product did not need to be coiled at low coiling temperatures to achieve its strengthening potential with the hot rolling. Moreover, the yield and tensile strength levels for the cast niobium steel was not significantly affected by the degree of inline hot rolling with a reduction of at least 19% to 37% as shown in FIG. 7.

[0080] The hardenability of the present steels is shown in FIG. 9. As shown in FIG. 9, a niobium level of as little as 0.007% was effective in increasing the strength of the final strip, and yield strength levels of over 380 MPa were achieved with niobium levels greater than about 0.01%. Note that niobium levels less than about 0.005% may be considered residual. Thus even very small additions of microalloying elements can be effective in substantial strengthening.

[0081] The high strengths were achieved by utilizing the niobium microalloying addition to increase the hardenability of the steel through the suppression of the formation of proeutectic ferrite. FIG. 4b shows that proeutectic ferrite formed along the prior austenite grain boundaries (allotriomorphic ferrite) in the base steel, but it was not present in the niobium steel shown in FIG. 4a. The hardenability effects of the niobium addition suppressed the ferrite transformation, hence enabling the stronger bainitic and acicular ferrite microstructure to be produced while using conventional cooling rates during cooling and higher coiling temperatures. The final microstructure of the present niobium steels comprises mostly a combination of bainite and acicular ferrite. The base steel shown in FIG. 4b was cooled to a relatively low coiling temperature, less than 500 °C, a cooling condition known to suppress ferrite formation at the austenite grain boundaries.

[0082] The effect of hot reduction on yield strength is reduced in the present niobium steel. In previous C-Mn products, there is typically a decrease in strength with increasing hot reduction. In contrast, as shown in FIG. 7, the effect of hot reduction on yield strength is significantly reduced in the present steel product. In this experiment, the coiling temperature was kept constant, and covering the range of hot rolling reductions up to at least 40% represented the strip thickness range of 1.0mm to 1.5mm. Unlike the non-microalloyed base steel, the strength levels of the niobium microalloyed steels of the present disclosure in the as-hot rolled cast strip product are relatively insensitive to the degree of hot rolled reduction for reductions up to at least 40%. Further, these high strength levels were achieved using conventional coiling temperatures in the range of 550 °C to 650 °C, as shown in FIG. 3.

[0083] To investigate this effect further, the austenite grain size was measured at each thickness in the 0.026 Nb steel. Where the base steel tended to be fully recrystallized above about 25% hot reduction, the 0.026 Nb steel showed only limited recrystallization even at 40% reduction. This indicates that the niobium in solid solution reduced the effect of hot reduction on the strength properties by suppressing static recrystallization of the deformed austenite after hot rolling. This is shown in FIG. 10, where it can be seen that the austenite grains have been elongated by the hot rolling reduction without recrystallising into finer grains. Finer grains increase the austenite grain boundary area, thereby reducing the steel hardenability. However, while recrystallization to a finer austenite grain size was suppressed, such high hot rolling reductions are known to raise the ferrite transformation start temperature. In addition, high hot rolling reduction can induce local high strain regions within the austenite grains, usually referred to as shear bands, which can act as intragranular

nucleation sites for ferrite nucleation. In the present steels, the hardenability effect of the niobium was sufficient to suppress the formation of ferrite within the deformed austenite grains, which resulted in strength levels that were largely insensitive to the degree of hot rolling.

[0084] The thin cast strip niobium steel product had consistent yield and tensile strength levels over the range of hot rolling applied, and capable of providing a yield strength of at least 410 MPa with a reduction of between 20% and 40%. The prior austenite grain size was determined for each strip thickness. The austenite grain size measurements indicated that only very limited recrystallization had occurred at high hot rolling reductions, whereas in the comparable base steel strip, the microstructure almost fully recrystallized at hot rolling reductions over about 25%. The addition of niobium to the cast steel strip suppressed the recrystallization of the coarse as-cast austenite grain size during the hot rolling process, and resulted in the hardenability of the steel being retained after hot rolling and retention of niobium in solution.

[0085] The higher strength of the present steel strip after hot rolling was mostly due to the microstructure formed. As shown in FIG. 4a, the microstructure of the cast niobium steel was comprised of a majority if not mostly bainite for all strip thicknesses. In contrast, as shown in FIG. 4b, the comparable non-microalloyed steel achieved similar strength by coiling at a low coiling temperature and had a microstructure comprising mostly acicular ferrite with some grain boundary ferrite. The addition of niobium to the steel strip provided an increase in the hardenability of the steel and suppressed the formation of the grain boundary ferrite and promoted the bainitic microstructure, even at considerably higher coiling temperatures.

[0086] The yield and tensile strength results from the trial steels, shown in Table 2 below, in the as-hot rolled condition are summarized in FIG. 11. The strength level increases with increasing niobium content, with yield strength of at least 340 MPa, with levels up to about 500 MPa in the as-hot rolled condition. The tensile strength may be at least 410 MPa. The initial rapid increase in strength is attributed to the suppression of proeutectic ferrite formation and the promotion of bainite and acicular ferrite, while the subsequent strengthening can be attributed to continued microstructural refinement and possibly solid solution hardening from niobium retained in solid solution.

[0087] In addition, transmission electron microscopy (TEM) examination did not reveal any substantial niobium precipitation in the as hot rolled cast strip. This indicates that the niobium had been retained in solid solution and that the strengthening produced was mainly attributed to the enhanced hardenability effect of the niobium resulting in the formation of a majority and likely predominantly bainitic microstructure. The hardenability of the cast steel strip is also believed to be enhanced by the retention of coarse austenite grain produced during formation of the cast strip. The transformation to bainite, rather than ferrite, is believed to be a major factor in suppressing the precipitation of the microalloy addition of niobium in the thin cast strip during cooling of the coil from the coiling temperature.

[0088] The transmission electron microscopy (TEM) examination may be used to determine the size, identity and volume fraction of niobium carbonitride particles present in the steel. The absence of any niobium carbonitride particles upon TEM examination supported the view that the observed strength was largely attributable to the microstructure being largely bainite rather than ferrite. The subsequent observed strengthening increment arising from an age hardening heat treatment therefore leads to the conclusion that niobium had been substantially in solution in the hot rolled strip. After determining the volume fraction of carbonitride particles in the microstructure using TEM analysis, the amount of microalloy element in solid solution can be concluded.

[0089] Thin foils or carbon replicates may be evaluated by TEM in determining the amount of the present carbonitride particles. In our analysis, a JEOL 2010 transmission electron microscope was used. However, from our experience with this instrument, Nb particles below 4 nanometers may not be resolvable in heavily dislocated ferrite.

[0090] For thin foil analysis, a foil is prepared. The foil is cut and ground to a thickness of 0.1 mm. The sample is then thinned to electron transparency by electro-polishing using a 5% perchloric acid, 95% acetic acid electrolyte in a Tenupole-2 electro-polishing unit. The sample can then be directly transferred to the TEM.

[0091] For carbon replication, a desired sample may be prepared by etching a polished sample in Nital (a solution of alcohol and nitric acid) after etching, coating the samples with carbon, and then scoring the carbon coating into appropriate dimensions (for example 2 mm square) for TEM analysis. After scoring, carbon replicas may be liberated from the sample by dissolving the ferrite matrix in 3% Nital. The carbon replica samples are

collected on 3mm diameter support grids, then repeatedly washed in ethanol/water solutions. The carbon extraction replica with the supporting grid can then be transferred to the TEM.

[0092] An additional factor believed to account for the absence of niobium carbonitride particles in the hot rolled cast strip relates to the nature of the dispersion of niobium with the rapid solidification of the strip during its formation by the method of continuously making cast strip described. In previously made microalloyed high strength strip, relatively long time intervals were involved in the solidification with slab cooling, slab reheating and thermo-mechanical processing that permitted opportunities for pre-clustering and/or solid state precipitation of carbonitride particles such as (Nb,V,Ti,Mo)(CN), that enabled the kinetics for subsequent precipitation through the stages of the manufacturing process. In the present process described, where the cast strip is continuously formed from a casting pool between casting rolls, the extremely rapid initial solidification in forming the cast strip (in about 160 microseconds) is believed to inhibit pre-clustering and/or solid state precipitation of carbonitride particles, and in turn, slow and reduce the kinetics for precipitation of the microalloys in subsequent processing including rolling and coiling operations. This means that the microalloys of Nb, V, Ti, and Mo are relatively more evenly distributed in the austenite and ferrite phases, than in thin steel strip previously made by conventional slab casting and processing.

[0093] Atom probe analysis of niobium cast strip made by forming from a casting pool between casting rolls as above described has verified the more even distribution of microalloys (indicating reduced pre-clustering and/or solid state precipitation) in both the as cast and the hot rolled strip when coiled at about 650 °C or lower. This more even distribution of elements is believed to be inhibiting the formation of carbonitrides in the coiling operation under conditions where fine coherent precipitation of such elements occurred in previous conventionally made and processed microalloyed slab cast steel. The reduction or absence of pre-clustering and/or solid state formation of carbonitrides in the microalloyed cast strip made by twin roll casting also slows the kinetics of formation of carbonitrides during subsequent thermo-mechanical processing such as annealing. This then permits the opportunity for age hardening at temperatures higher than those where the particles in previously conventionally processed strip lost their strengthening capacity through coarsening (Ostwald ripening) mechanisms.

[0094] With an age hardening heat treatment, higher tensile strength was found to be achievable. For example, with a 0.026% niobium addition, an increase of at least a 35 MPa

(about 5 ksi) increase in yield strength from 410 to 450 MPa (about 60-65 ksi) was observed. With a 0.05% niobium addition, it is contemplated that with a age hardening, an increase of at least 10 ksi is expected, and a with 0.1% niobium addition, it is contemplated that with a age hardening, an increase of at least 20 ksi is expected. The microstructure of the present age hardened steel product may have niobium carbonitride particles with an average particle size of 10 nanometers and less. The microstructure of the age hardened steel product may have substantially no niobium carbonitride particles greater than 50 nanometers.

[0095] Laboratory ageing heat treatments were conducted on samples of 0.026 % niobium steels at various temperatures and times to induce action of the niobium, that was believed retained in solid solution in the hot rolled strip. As shown in FIG. 5, ageing heat treatments produced a significant increase in strength, with yield strengths of about 480MPa (about 70 ksi). This confirmed that the niobium was retained in a solid solution and was available to provide age hardening on subsequent ageing, for example, through the use of an annealing furnace on continuous galvanizing lines or by using a continuous annealing line. Accordingly, short time age hardening is carried out to simulate the ageing potential from processing the niobium microalloyed cast steel product through an annealing furnace attached to continuous galvanizing line or conventional continuous annealing line. In the latter case the age hardened high strength strip product maybe subsequently galvanized, painted or utilized uncoated.

[0096] The results, as shown in FIG. 6, clearly show that for a peak processing temperature of 700 °C (1292 °F), significant strengthening was realized, with strength levels approaching that achieved for the longer times at lower temperatures. The tensile properties of the niobium thin cast steel product after the short time ageing treatment using a peak temperature of 700 °C (1292 °F) are given in Table 1. Besides the high strength of the cast strip product, the ductility and formability is satisfactory for structural quality products. The cast strip product produced is a thin, high strength strip product for structural applications through the use of niobium microalloying. It is contemplated that higher microalloying levels would realize even higher yield strengths, potentially well in excess of 550 MPa (about 80 ksi).

TABLE 1

Strip Thickness, mm	Yield Strength, MPa	Tensile Strength, MPa	Total Elongation, %	YS/TS	'n' Value	'r' Value
1.1	477	563	18	0.85	0.12	0.90

[0097] Recently, in addition to producing the 0.026 wt% niobium steel, steels with niobium additions of 0.014 wt% and 0.065 wt% have been successfully produced via the present process. Heat compositions are shown below in Table 2.

TABLE 2

Steel	<u>C (wt%)</u>	<u>Mn (wt%)</u>	<u>Si (wt%)</u>	<u>Nb (wt%)</u>	<u>V (wt%)</u>	<u>N (wt%)</u>
A	0.032	0.72	0.18	0.014	<0.003	0.0078
B	0.029	0.73	0.18	0.024	<0.003	0.0063
C	0.038	0.87	0.24	0.026	<0.003	0.0076
D	0.032	0.85	0.21	0.041	<0.003	0.0065
E	0.031	0.74	0.16	0.059	<0.003	0.0085
F	0.030	0.86	0.26	0.065	<0.003	0.0072
G	0.028	0.82	0.19	0.084	<0.003	0.0085
H	0.026	0.90	0.21	<0.003	0.042	0.0070
Base Steel	0.035	0.85	0.27	<0.003	<0.003	0.0060

[0098] The yield strengths achieved for steel C and steel F are shown in FIG. 12, and the yield strength results for the 0.014% Nb heat, steel A, produced with a lower Mn content, are presented in FIG. 13. The niobium additions increased the yield strength at all coiling temperatures relative to the base steel composition. The yield strength increased by about 70 to 100 MPa (10 to 15 ksi) for the 0.014% Nb and 0.026 Nb additions, and by about 140 to 175 MPa (20-25 ksi) for the 0.065 Nb addition. From FIG. 12 it can be seen that the 0.026% Nb steel achieved higher yield strengths than the 0.8 Mn base steel for similar coiling temperatures, and comparable yield strengths to when the 0.8 Mn base steel was coiled at low temperatures. Alternatively, the strengths achieved in the 0.8 Mn base steel at low coiling temperatures (about 500°C) can be achieved at higher coiling temperatures (about 600°C) with this Nb addition.

[0099] Additionally, in contrast to previous conventionally produced microalloyed steel, we have found that the microalloy addition suppresses the formation of carbonitride

particles in the hot rolled and subsequently coiled and cooled steel. Instead, the microstructure of the hot rolled and subsequently coiled and cooled steel comprises bainite and acicular ferrite with more than 70% niobium and/or vanadium remaining in solid solution. Alternately, the microstructure of the hot rolled and subsequently coiled and cooled steel may comprise bainite and acicular ferrite with more than 80% niobium and/or vanadium remaining in solid solution, and alternately may have more than 90 % remaining in solid solution.

[00100] Thus, it has been shown that the niobium cast strip results in light gauge, high strength, steel product. The niobium addition firstly is capable of suppressing the austenite recrystallization during hot rolling, which enhances the hardenability of the steel by retaining the relatively coarse as cast austenite size. The niobium being retained in solid solution in austenite after hot rolling, directly increases the steel's hardenability, which assists in transforming the austenite to a final microstructure comprised mostly of bainite, even at relatively high coiling temperatures. The formation of a bainitic microstructure promoted the retention of the niobium addition in solid solution in the hot rolled strip.

[00101] Further improvement in properties may be obtained by age hardening the present steels. In previous microalloyed and non-microalloyed steels, an increase in strength could be obtained by age hardening, but in such prior steels, a decrease in elongation occurs with an increase in strength. We have found that both an increase in elongation and an increase in strength may be obtained by age hardening the present steels.

[00102] It was determined that the retention of the microalloying elements such as niobium and vanadium in solid solution by the prior processing conditions provided considerable hardenability for subsequent age hardening cycle. Such an age hardening cycle can be produced using a suitable continuous galvanizing line or continuous annealing facility. Hence a microalloyed steel strip made using a thin strip casting process, combined with an age hardening heat treatment provided by a suitable galvanizing line or annealing line, is a unique manufacturing path providing a unique strengthening approach for this type of steel product.

[00103] Isothermal ageing treatments of the hot rolled 0.026% Nb cast strip material were carried out for 20 minutes at 600 °C and 650 °C (1110 °F and 1200 °F), inducing formation of niobium carbonitrides, or Nb(C,N), as confirmed by TEM examination. This resulted in an increase in yield strength of the material, as shown in FIG. 14. Also, as shown

in FIGS. 6 and 14, the thermal cycle of strip through the annealing section of a galvanizing line also induced a significant strength increase, approaching that achieved with the isothermal aging at lower temperatures.

[00104] The increase in the hardenability provided by the microalloy addition through the suppression of the ferrite transformation significantly lowers the austenite decomposition temperature into the bainite/acicular ferrite temperature range. This lower transformation start temperature provides the potential to retain the vast majority of the microalloy addition in solid solution by applying conventional run out table cooling rates and appropriate coiling temperatures.

[00105] The microalloying elements, such as niobium and vanadium, in solid solution are available for age hardening during a subsequent heat treatment to increase strength. Laboratory age hardening studies established that substantial strengthening could be achieved even with relatively short heat treatment cycles, such as available with continuous annealing lines and galvanizing lines. The results from laboratory simulated continuous annealing cycles applied to trial Steel C (0.026% Nb), Steel F (0.065% Nb), and Steel G (0.084% Nb) are shown in FIGS. 15, through 18.

[00106] The results from full scale plant trials with steels B and F, using the heat treatment conditions established from the laboratory study are given in FIGS. 20 and 21, respectively. Substantial strength increases were achieved with steels B and F. Yield strength levels in excess of 450 MPa were recorded with the 0.024% Nb steel (steel B) and yield strengths over 550 MPa with the 0.065% Nb steel (steel F). Strength increase from the age hardening was in the order of 70 MPa (10 ksi) for the 0.024% Nb steel (steel B) and up to about 100 MPa (15 ksi) for the 0.065% Nb steel (steel F). It is contemplated that the 0.065% Nb steel may achieve yield strengths over 600 MPa in the age hardened condition.

TABLE 3

Steel F	Thickness mm	Yield Strength MPa	Tensile Strength MPa	Elongation %
Hot band	0.996	512	599	11.47
Galvanized	0.991	581	645	14.16

[00107] Samples of steel F were age hardened on using the age hardening conditions found on a galvanizing line. As shown in TABLE 3, the age hardened steel had a strength of almost 70 MPa, and the elongation increased from 11.47% to 14.16%. The relationship between yield strength and total elongation for the presently disclosed niobium steels in the as hot rolled condition and in the age hardened and galvanized condition (longitudinal test direction) is shown in FIG. 19.

[00108] As shown in FIG. 16, we have found that a 10 second hold cycle may be used between about 675 °C to 725 °C to prevent overaging. However, the temperature range is a function of the holding time. Increasing the hold time to 20 seconds lowered the temperature range slightly, while for the zero hold time, the temperature range was increased slightly, as shown in FIG. 17. The age hardening temperature range may be between about 625 °C and 800 °C depending upon on the overall heat treatment cycle time, i.e. heating rates, the holding time, and cooling rates.

[00109] In the case of longer time heat treatments, lower temperatures in the range of 500 °C to 650 °C may be used. From FIG. 6 it can be seen that a heat treatment of 20 minutes at 600 °C produces similar strength levels as 10 seconds in a continuous annealing cycle at 700 °C. FIG. 22 shows results of laboratory heat treatments carried out for 20 and 120 minutes. The results show that substantial hardening was achieved for a heat treatment of 120 minutes at 550 °C, but the 120 minute aging at temperatures over about 650 °C reduced the hardness of the steel. Longer heat treatment times could be used with full coil annealing processes, such as batch annealing in the temperature range of 500 °C to 650 °C, or other post coiling cooling practices for the hot rolled coil, designed to precipitate the retained niobium, by controlled cooling through the temperature range 500 °C to 650 °C.

[00110] Transmission electron microscopy (TEM) was carried out on samples of steels C and F, which had been given a heat treatment of 60 minutes at 650 °C. Fine particles in the size range of 4 to 15 nanometers were found. These fine particles were found to include niobium carbonitrides, indicating that the strengthening may be attributed to age hardening by fine niobium carbonitride particles.

[00111] The microstructure of the age hardened microalloyed steel product may have niobium carbonitride particles, with an average particle size of 10 nanometers and less. The microstructure of the age hardened steel product may have substantially no niobium carbonitride particles greater than 50 nanometers. Samples of the present niobium steel were

inspected using TEM evaluation, and portions of the microstructure had no measurable amount of niobium carbonitride particles.

[00112] We believe that the enhanced strength/elongation relationship in the present age hardened steel may be due to portions of the microstructure being substantially free of particles greater than 5 nanometers in size, or "precipitate free zones," and nano-clusters. The development of precipitate free zones in the vicinity of grain boundaries may influence the strength and tensile elongation relationship by providing reduced hardness regions adjacent to grain boundaries. The relaxation of stress concentrations in precipitate free zones has been reported to enhance strength and elongation. The beneficial effects of precipitate free zones on elongation and strength may appear in circumstances where the precipitate free zones are narrow and the size of grain boundary precipitates is small.

[00113] In the present steel, the element additions may provide for increased elongation with increased strength after age hardening by producing smaller precipitate free zone width and smaller change in hardness than in conventionally produced niobium steels. Because of the more even dispersion of elements in rapidly solidified steels, the kinetics of age hardening can be retarded so as to effectively expand the time-temperature window over which the formation of nano-clusters can be stably controlled. The element nano-clusters may provide strengthening in the early stages of age hardening. Cluster strengthening may be due to the extra energy required for dislocations to cut the diffuse boundary of the cluster of solute species. The clusters may provide substantial strengthening without reducing ductility because their elastically soft boundaries do not severely inhibit dislocation movement or cause pile-ups in the way that normal second phase particles do.

[00114] In the present steels, a more even distribution of elements remains in solid solution during the rapid solidification of steel. In contrast to previous conventionally produced niobium and vanadium steels, the microstructure of the hot rolled and subsequently coiled and cooled steel comprises bainite and acicular ferrite with more than 70% niobium and/or vanadium addition remaining in solid solution and substantially no niobium carbonitride particles greater than 50 nanometers. Alternately, the microstructure of the hot rolled and subsequently coiled and cooled steel may comprise bainite and acicular ferrite with more than 80% niobium and/or vanadium addition remaining in solid solution, and alternately may have more than 90% remaining in solid solution.

[00115] The elements remain trapped in solution in the hot rolled coil and do not precipitate if the coiling temperature is below about 650 °C. Formation is effectively retarded because the prior associations of atoms (such as in the form of particles) that normally occur in conventional slab casting and reheating for hot strip rolling are prevented in the present process. The observed increase in strength that occurs in the hot rolled coils may thus be largely attributable to hardenability and solid solution hardening effects.

[00116] Formation of carbonitride particles can be activated during heat treatment. Additionally, during age hardening, pre-precipitation clusters and finer particles are stable over an extended range of time and temperature because of the significant amount of niobium and/or vanadium in solid solution prior to age hardening. The precipitate free zones that form near grain boundaries as a normal precipitation phenomenon are narrower and contain more evenly dispersed nano-clusters and finer precipitates than for conventionally produced steels. Thus the hardness changes in the precipitate free zones relative to the grain interior are relatively small for the present steels. We believe that narrower precipitate free zones and small hardness changes across precipitate free zones reduce stress concentrations in the precipitate free zones reducing microcracking from preferential deformation in the precipitate free zones. We believe that the cluster strengthening may be characterized by a strength increase without a deterioration in ductility since dislocation pile-up does not occur at clusters. The combination of narrow precipitate free zones and cluster strengthening mechanisms is believed to lead to precipitate free zones of the present steels. This results in improved elongation because cracks are more difficult to initiate and less constrained to the grain boundary precipitate free zone region. Further, the nano-clusters may co-exist with distinct particles within the grain interior regions over a certain annealing temperature/time combinations.

[00117] An annealing furnace may be used to perform the age hardening, which is not a current strengthening approach for processing such products. The annealing condition may be a continuous annealing cycle with a peak temperature of at least 650 °C and less than 800 °C and better 675 °C to 750 °C. Alternately, strengthening may be achieved in a production environment using a very short age hardening cycle available with conventional annealing furnaces incorporated in continuous galvanizing lines. The final strength levels recorded in the full scale plant trials were similar to that produced with the laboratory heat treatments of the respective steels.

[00118] Similar results are contemplated with niobium between about 0.01% and about 0.20%, as well as with titanium between about 0.01% and about 0.20%, molybdenum between about 0.05% and about 0.50%, and vanadium between about 0.01% and about 0.20%.

[00119] The composition of the present steel utilizing vanadium is shown as steel H in Table 2. The yield strength of steel H is shown in FIG. 23. The vanadium steel was produced with two different coiling temperatures, and was subsequently aged for 20 minutes at 650 °C and 700 °C to induce hardening by vanadium in solid solution. The results show that significant strengthening was achieved from these heat treatment conditions. The strengthening increment was slightly higher for the material produced with the higher coiling temperature, which may be due to the effects of opposing processes of precipitation hardening and microstructural softening. The strengthening increment realized with the material produced at the lower coiling temperature was of the same order of that achieved with the 0.026% Nb steel.

[00120] The yield strength of steel H in the as-hot rolled and galvanized conditions are presented in FIG. 24. FIGS. 23 and 24 indicate that the vanadium steel achieved higher strength levels than the plain carbon base steel, even though it was produced using higher coiling temperatures. In the samples shown in FIG. 24, the coiling temperature of steel H was 570 °C, and the base steel coiling temperature was less than 500 °C.

[00121] Also shown in FIG. 24, a strength increase was realized in the vanadium steel from an age hardening using the annealing furnaces on a continuous galvanizing line, but the strength increase was less than was realized from an equivalent niobium content. The yield strength of the sample in FIG. 24 on the galvanizing line was about 450 MPa in the galvanized condition, which is in the order achieved with the longer term laboratory heat treatments shown in FIG. 23. The strength of the vanadium steel may be more sensitive to coiling temperature than the niobium steels.

[00122] This thin cast strip enables production of new steel product types including:

[00123] 1. A high strength, light gauge, galvanized strip by utilizing a microstructure that has bainite as the major constituent and age hardening during the galvanizing process. The annealing section of the galvanizing line can be used to induce age hardening of the niobium and/or vanadium of the thin cast strip that has been hot rolled.

[00124] 2. A high strength, light gauge, uncoated strip by utilizing a microstructure that is majority bainite and age hardened during processing on a continuous annealing line. The high temperature furnace of the conventional continuous annealing can be used to induce activation of the niobium and vanadium elements retained in solid solution by the bainite microstructure after hot rolling of the thin cast strip.

[00125] 3. A high strength, light gauge, hot rolled cast strip product where the strength levels are insensitive to the degree of hot rolling reduction applied. The bainitic microstructure produces a relatively high strength product ($YS \geq 380$ MPa (~55ksi)). The suppression of austenite recrystallization during or after hot rolling can provide final strength levels insensitive to the degree of hot rolling reduction. The final strength levels will be consistent across a range of thicknesses that can be produced by a thin cast strip process.

[00126] While the invention has been illustrated and described in detail in the foregoing drawings and description, the same is to be considered as illustrative and not restrictive in character, it being understood that only illustrative embodiments thereof have been shown and described, and that all changes and modifications that come within the spirit of the invention described by the following claims are desired to be protected. Additional features of the invention will become apparent to those skilled in the art upon consideration of the description. Modifications may be made without departing from the spirit and scope of the invention.

What is claimed is:

1. A steel product comprising, by weight, less than 0.25% carbon, between 0.20 and 2.0% manganese, between 0.05 and 0.50% silicon, less than 0.01% aluminum, and niobium between about 0.01% and about 0.20% and having a majority of the microstructure comprised of bainite and acicular ferrite and having more than 70% niobium in solid solution.
2. The steel product as claimed in claim 1 where the niobium is less than 0.1%.
3. The steel product as claimed in claim 1 further comprising at least one element selected from the group consisting of molybdenum between about 0.05% and about 0.50%, vanadium between about 0.01% and about 0.20%, and a mixture thereof.
4. The steel product as claimed in claim 1 where the steel product has a yield strength of at least 340 MPa.
5. The steel product as claimed in claim 1 where the steel product has a tensile strength of at least 410 MPa.
6. The steel product as claimed in claim 1 where the steel product has a yield strength of at least 410 MPa.
7. The steel product as claimed in claim 1 where the steel product has a tensile strength of at least 485 MPa.
8. The steel product as claimed in claim 1 where the steel product has a yield strength of at least 450 MPa.
9. The steel product as claimed in claim 1 where the steel product has a tensile strength of at least 520 MPa.

10. The steel product as claimed in claim 1 where the steel product has a total elongation of at least 6%.
11. The steel product as claimed in claim 1 where the steel product has a total elongation of at least 10%.
12. A thin cast steel strip of less than 3 millimeters in thickness comprising, by weight, less than 0.25% carbon, between 0.20 and 2.0% manganese, between 0.05 and 0.50% silicon, less than 0.01% aluminum, and niobium between about 0.01% and about 0.20% and having a majority of the microstructure comprised of bainite and acicular ferrite and having more than 70% niobium in solid solution.
13. The thin cast steel strip as claimed in claim 12 where the niobium is less than 0.1%.
14. The thin cast steel strip as claimed in claim 12 further comprising at least one element selected from the group consisting of molybdenum between about 0.05% and about 0.50%, vanadium between about 0.01% and about 0.20%, and a mixture thereof.
15. The thin cast steel strip as claimed in claim 12 comprising in addition having fine oxide particles of silicon and iron distributed through the steel microstructure having an average particle size less than 50 nanometers.
16. The thin cast steel strip as claimed in claim 12 where the thin cast steel strip has a yield strength of at least 340 MPa.
17. The thin cast steel strip as claimed in claim 12 where the thin cast steel strip has a tensile strength of at least 410 MPa.
18. The thin cast steel strip as claimed in claim 12 where the steel product has a yield strength of at least 410 MPa.
19. The thin cast steel strip as claimed in claim 12 where the steel product has a tensile strength of at least 485 MPa.

20. The thin cast steel strip as claimed in claim 12 where the steel product has a yield strength of at least 450 MPa.
21. The thin cast steel strip as claimed in claim 12 where the steel product has a tensile strength of at least 520 MPa.
22. The thin cast steel strip as claimed in claim 12 where the thin cast steel strip has a thickness of less than 2.5 mm.
23. The thin cast steel strip as claimed in claim 12 where the thin cast steel strip has a thickness of less than 2.0 mm.
24. The thin cast steel strip as claimed in claim 12 where the thin cast steel strip has a thickness in the range from about 0.5 mm to about 2 mm.
25. The thin cast steel strip as claimed in claim 12 where the thin cast steel strip has a total elongation of at least 6%.
26. The thin cast steel strip as claimed in claim 12 where the thin cast steel strip has a total elongation of at least 10%.
27. A hot rolled steel product of less than 3 millimeters thickness comprising, by weight, less than 0.25% carbon, between 0.20 and 2.0% manganese, between 0.05 and 0.50% silicon, less than 0.01% aluminum, and niobium between about 0.01% and about 0.20%, and having a majority of the microstructure comprised of bainite and acicular ferrite and capable of providing a yield strength of at least 410 MPa with a reduction of between 20% and 40% .
28. The hot rolled steel product as claimed in claim 27 where the niobium is less than 0.1%.

29. The hot rolled steel product as claimed in claim 27 further comprising at least one element selected from the group consisting of molybdenum between about 0.05% and about 0.50%, vanadium between about 0.01% and about 0.20%, and a mixture thereof.
30. The hot rolled steel product as claimed in claim 27 comprising in addition having fine oxide particles of silicon and iron distributed through the steel microstructure having an average particle size less than 50 nanometers.
31. The hot rolled steel product as claimed in claim 27 where the steel product has a yield strength of at least 340 MPa.
32. The hot rolled steel product as claimed in claim 27 where the steel product has a tensile strength of at least 410 MPa.
33. The hot rolled steel product as claimed in claim 27 where the steel product has a thickness of less than 2.5 mm.
34. The hot rolled steel product as claimed in claim 27 where the steel product has a thickness of less than 2.0 mm.
35. The hot rolled steel product as claimed in claim 27 where the steel product has a thickness in the range from about 0.5 mm to about 2 mm.
36. The hot rolled steel product as claimed in claim 27 where the steel product has a total elongation of at least 6%.
37. The hot rolled steel product as claimed in claim 27 where the steel product has a total elongation of at least 10%.

38. A method of preparing coiled thin cast steel strip comprising the steps of:
assembling internally a cooled roll caster having laterally positioned casting rolls forming a nip between them, and forming a casting pool of molten steel supported on the casting rolls above the nip and confined adjacent the ends of the casting rolls by side dams,
counter rotating the casting rolls to solidify metal shells on the casting rolls as the casting rolls move through the casting pool, and
forming from the metal shells downwardly through the nip between the casting rolls a steel strip, and
cooling the steel strip at a rate of at least 10 °C per second to provide a composition comprising by weight, less than 0.25% carbon, between 0.20 and 2.0% manganese, between 0.05 and 0.50% silicon, less than 0.01% aluminum, and niobium between about 0.01% and about 0.20%, and having a majority of the microstructure comprised of bainite and acicular ferrite and having more than 70% niobium in solid solution.
39. The method of preparing coiled thin cast steel strip as claimed in claim 38 where the steel strip as coiled may have fine oxide particles of silicon and iron distributed through the steel microstructure having an average particle size less than 50 nanometers.
40. The method of preparing coiled thin cast steel strip as claimed in claim 38 further comprising the steps of:
hot rolling the steel strip; and
coiling the hot rolled steel strip at a temperature between about 450 °C and 700 °C.
41. The method of preparing coiled thin cast steel strip as claimed in claim 38 further comprising the steps of:
hot rolling the steel strip; and
coiling the hot rolled steel strip at a temperature less than 600 °C.

42. The method of preparing coiled thin cast steel strip as claimed in claim 38 further comprising the step of:
age hardening the steel strip to increase the tensile strength at a temperature of at least 550 °C.
43. The method of preparing coiled thin cast steel strip as claimed in claim 38 further comprising the step of:
age hardening may occur at a temperature between 625 °C and 800 °C.
44. The method of preparing coiled thin cast steel strip as claimed in claim 38 further comprising the step of:
age hardening may occur at a temperature between 650 °C and 750 °C.

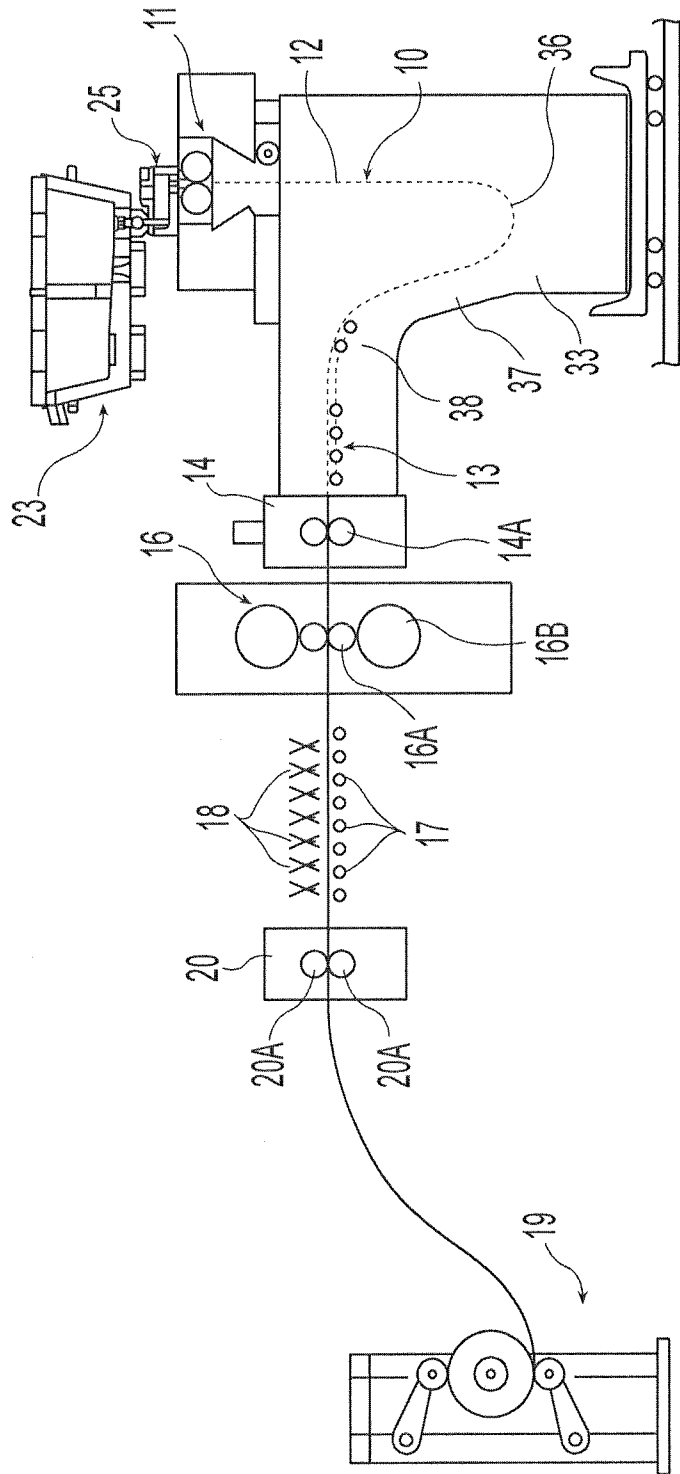

Fig. 1

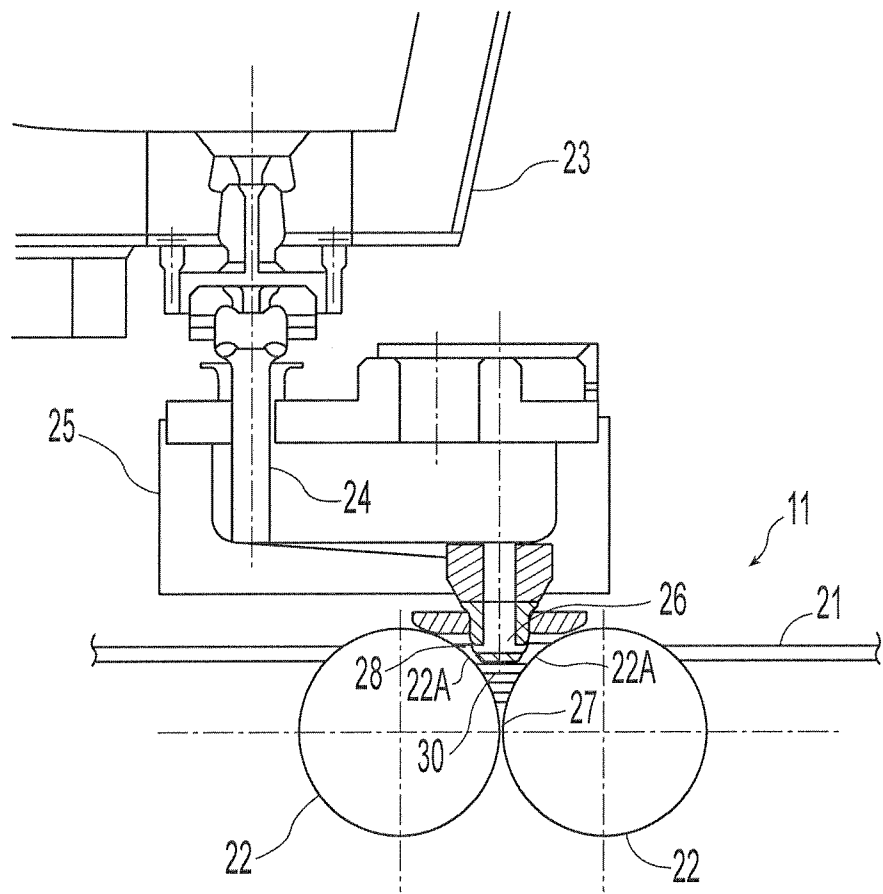

Fig. 2

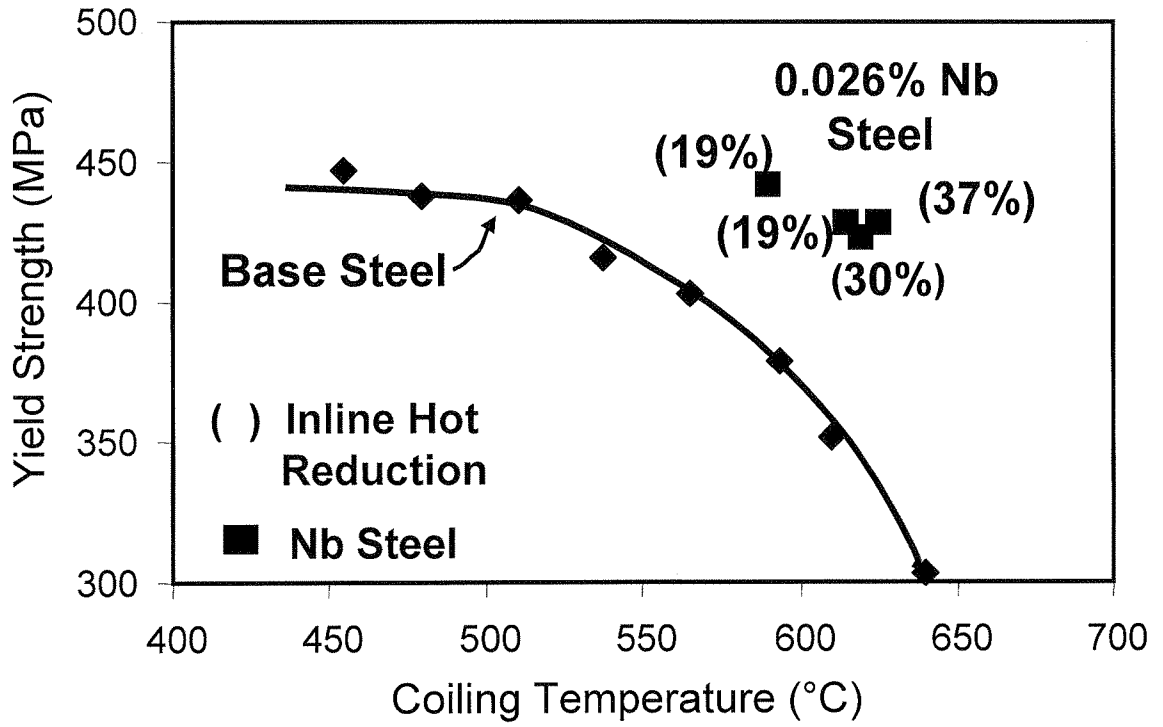

Fig. 3

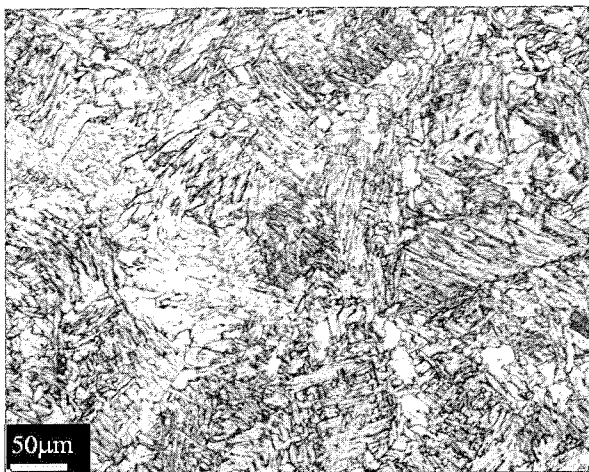

Fig. 4a

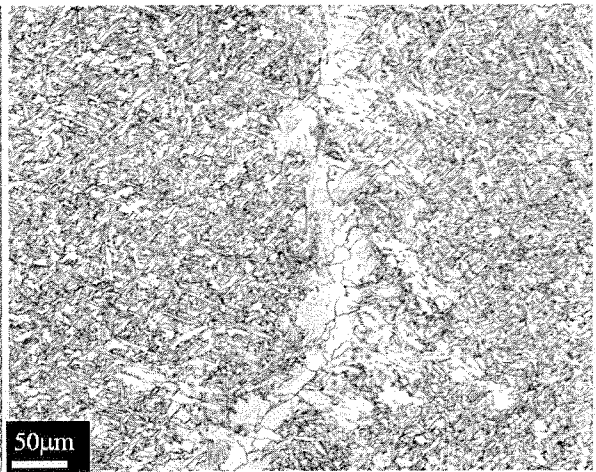

Fig. 4b

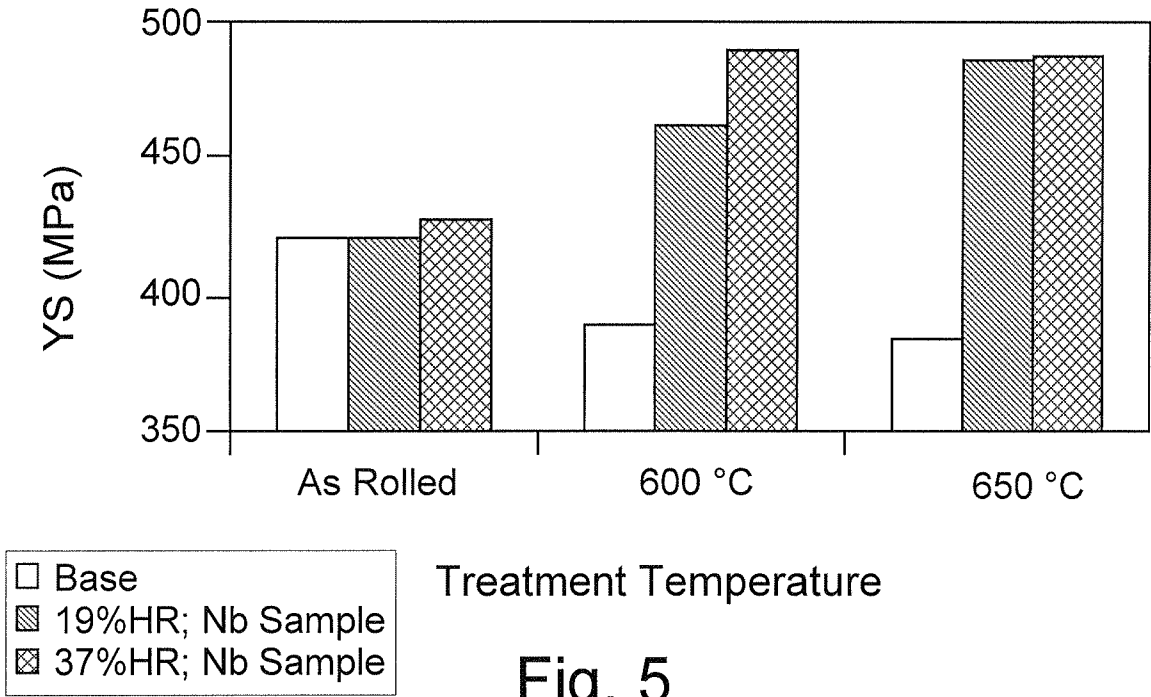

Fig. 5

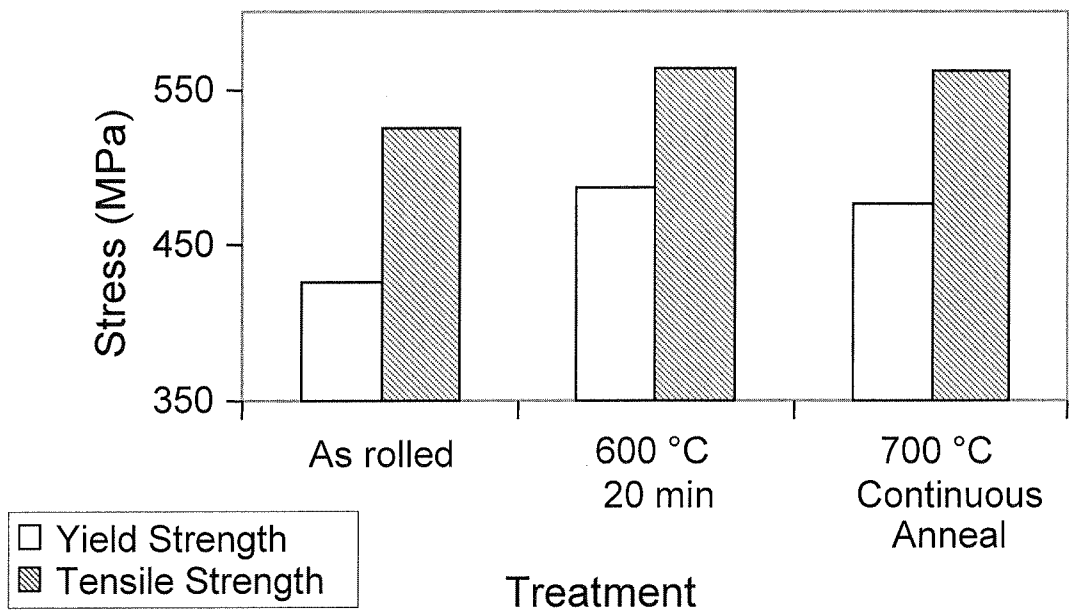

Fig. 6

5/13

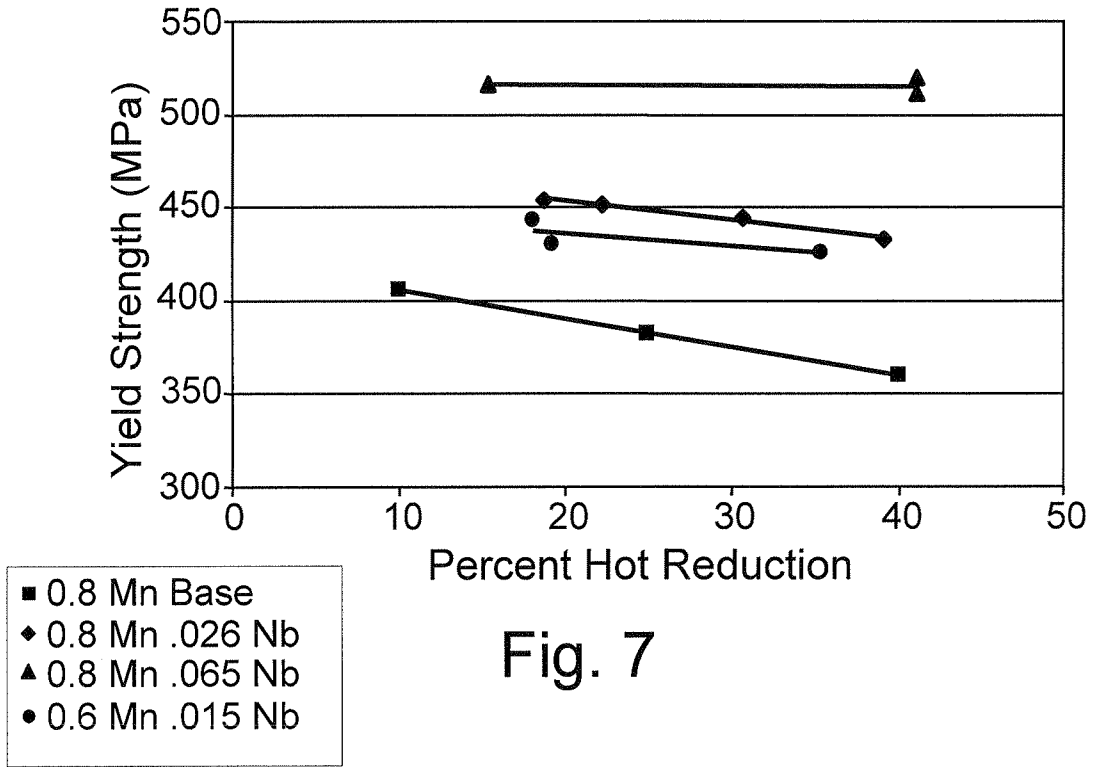

Fig. 7

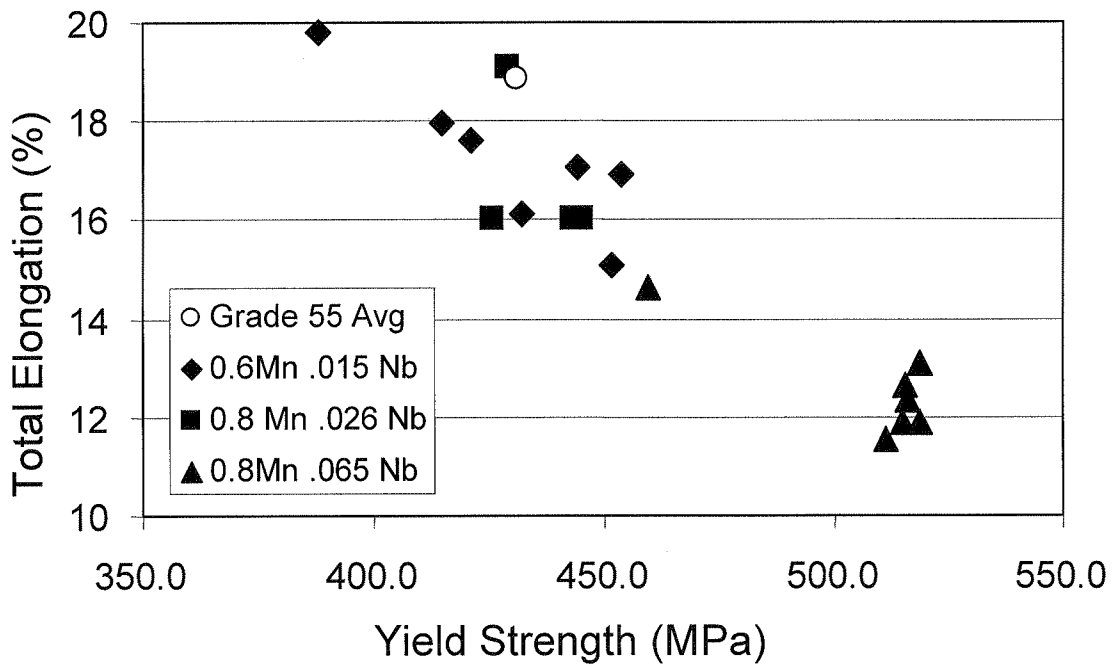

Fig. 8

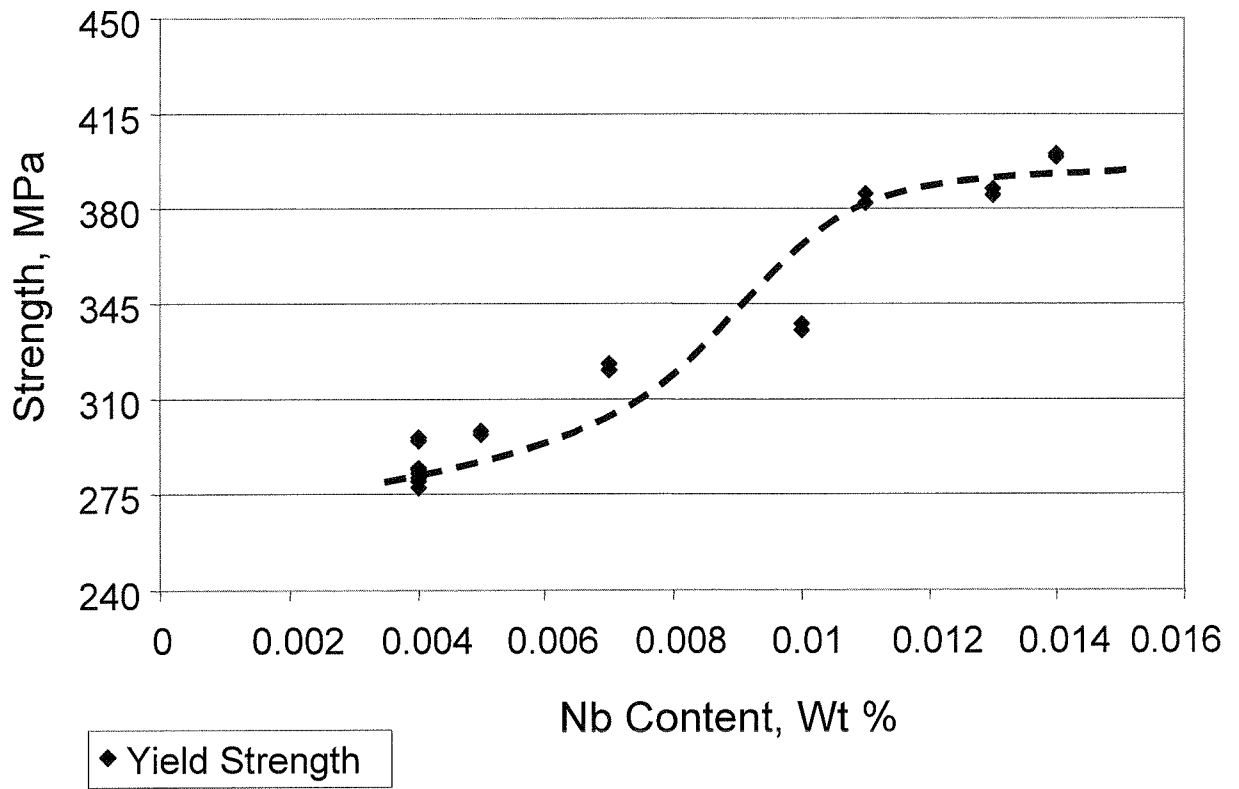

Fig. 9

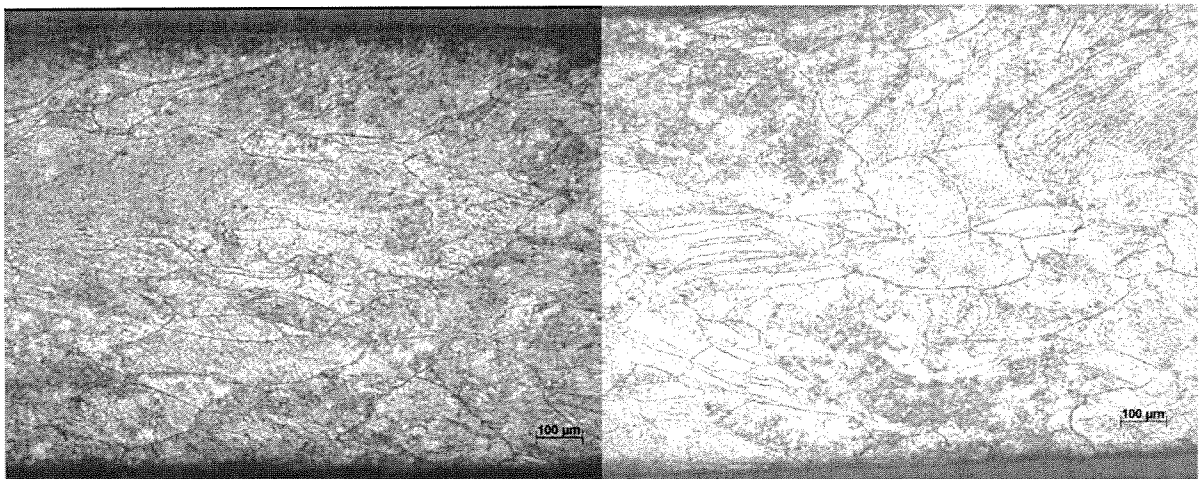

Fig. 10a

Fig. 10b

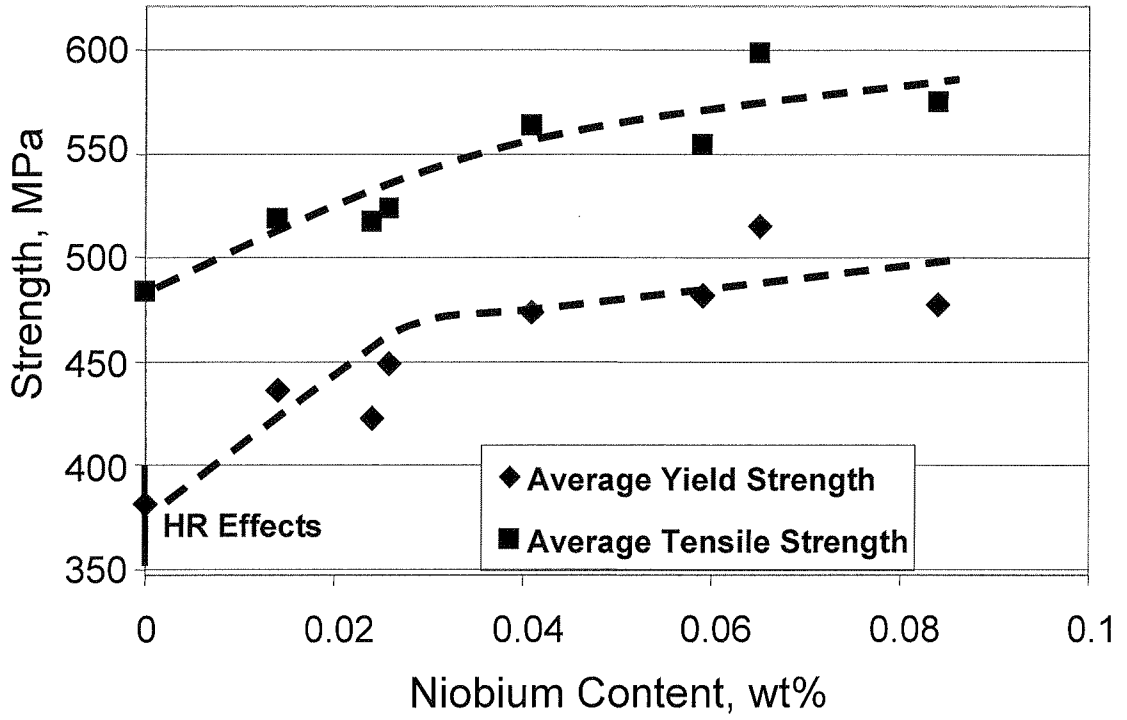

Fig. 11

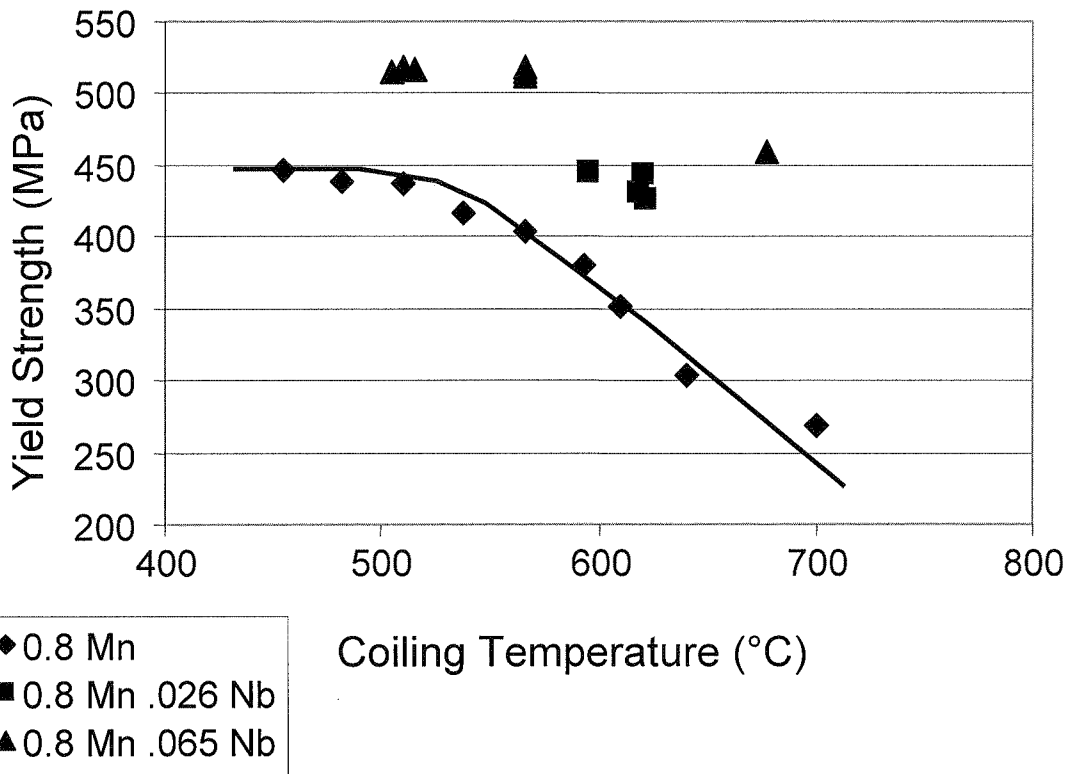

Fig. 12

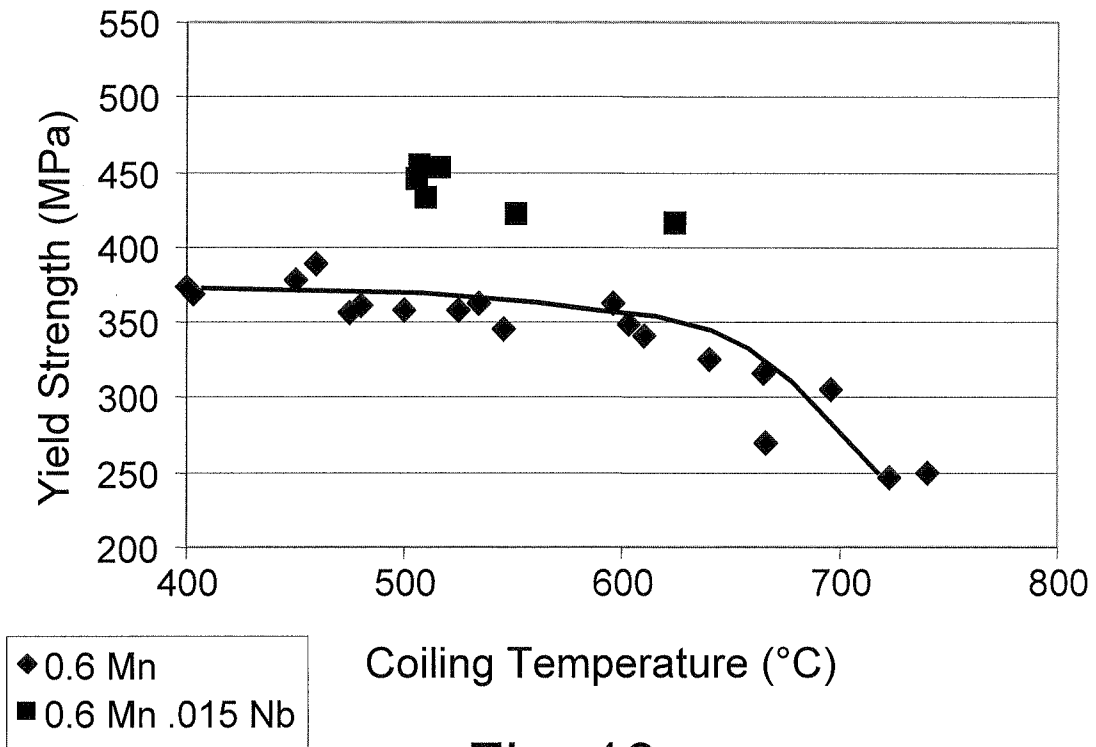

Fig. 13

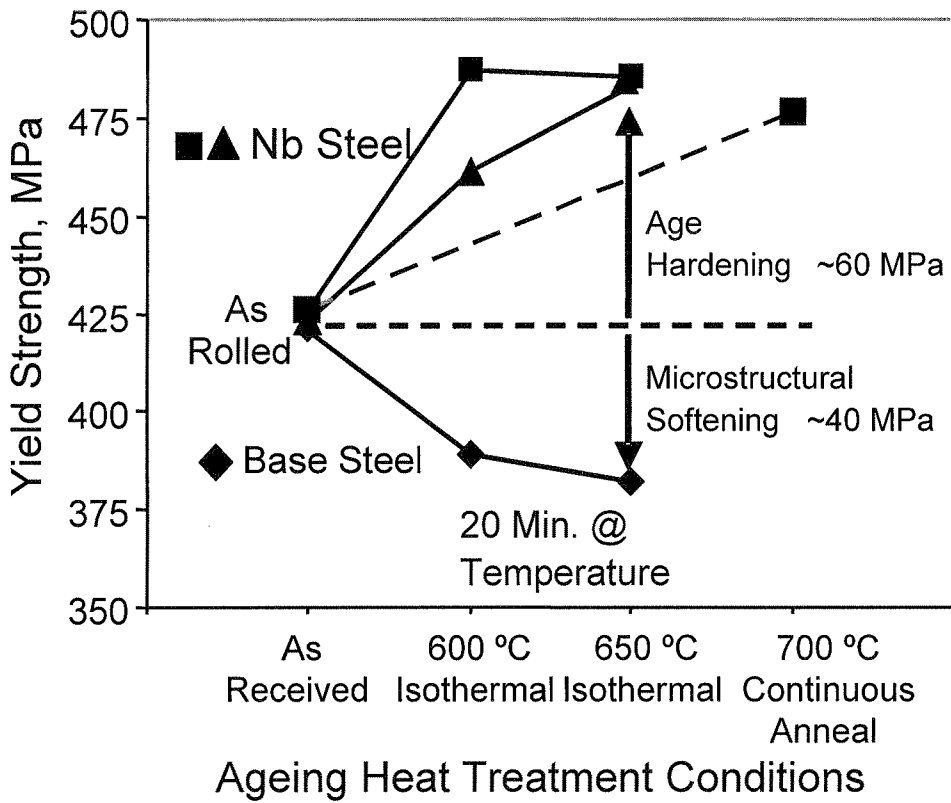

Fig. 14

Laboratory Heat Treatment of a 0.026% Nb steel for 10 Seconds Hold at Peak Temperature

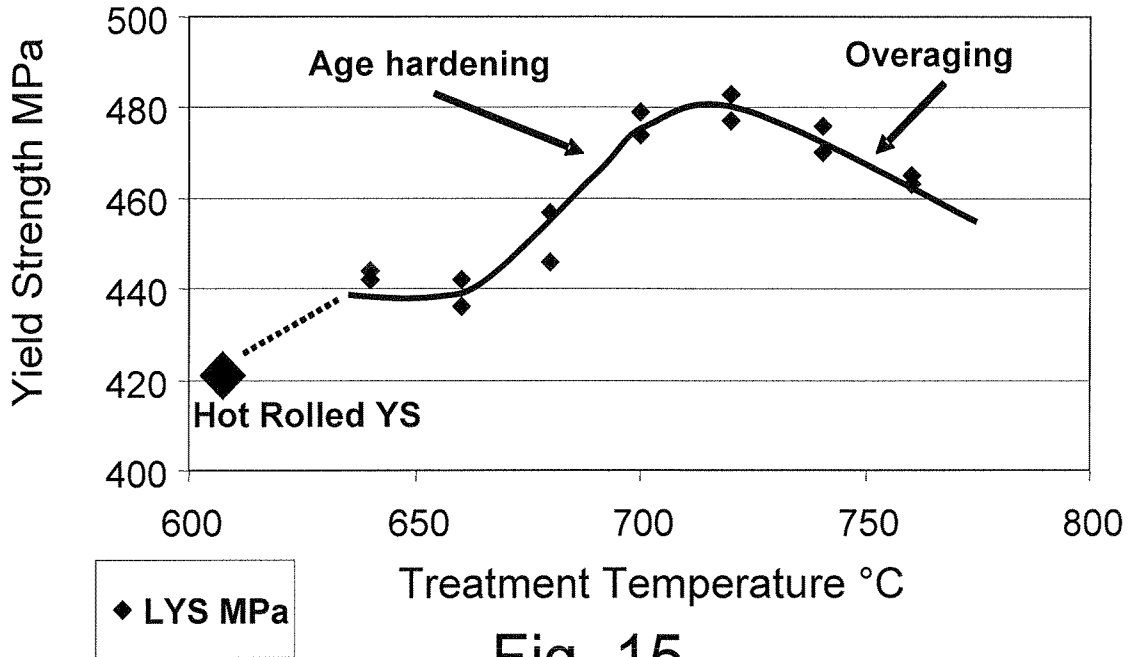

Fig. 15

Laboratory Ageing Heat Treatments (0.065% Nb)

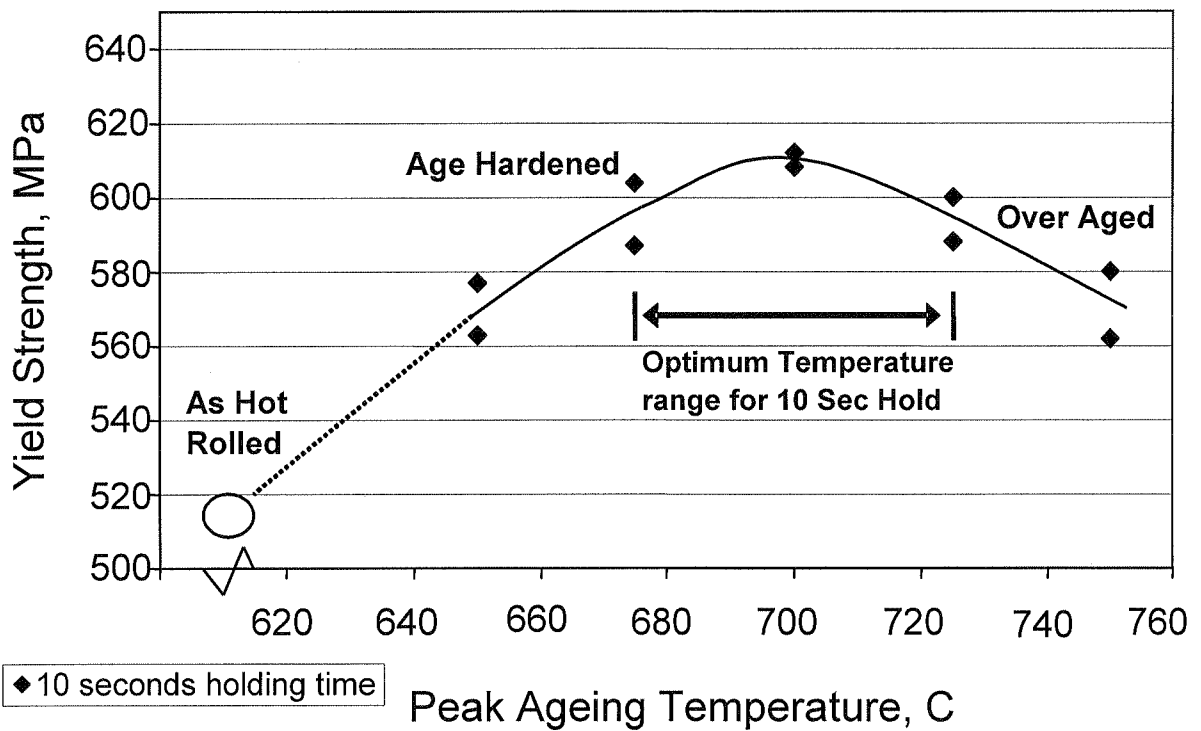

Fig. 16

10/13

Laboratory Ageing Heat Treatments (0.065% Nb)

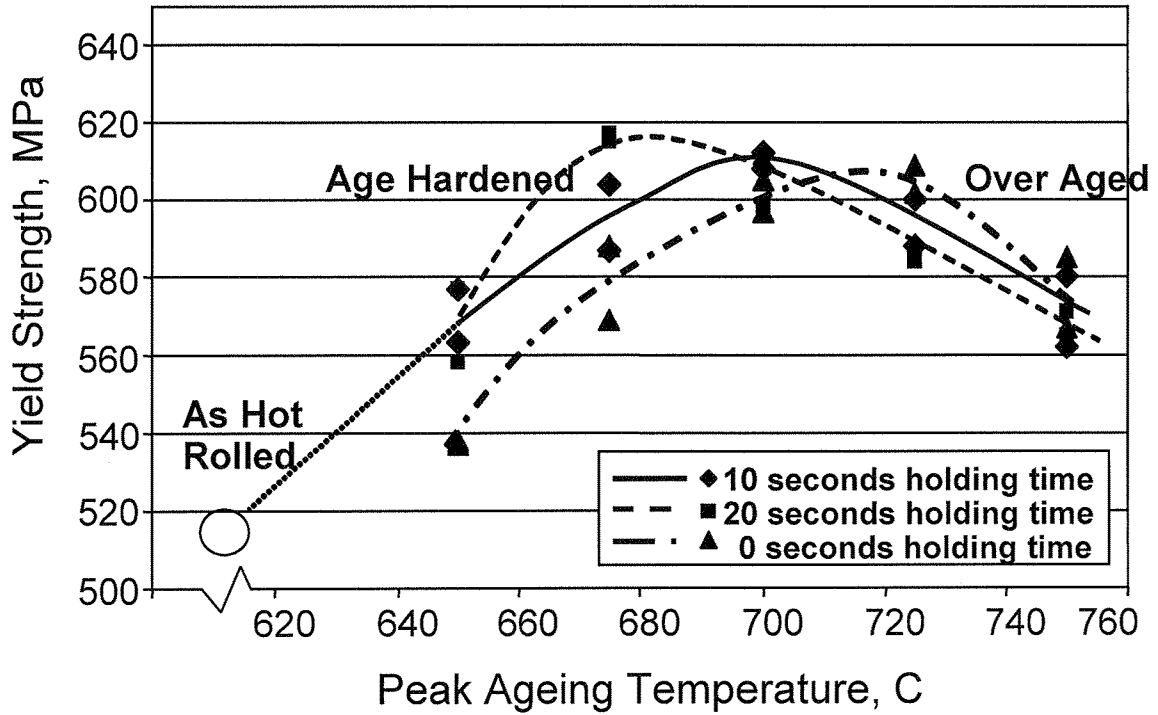

Fig. 17

Age Hardening Response (0.084% Nb)

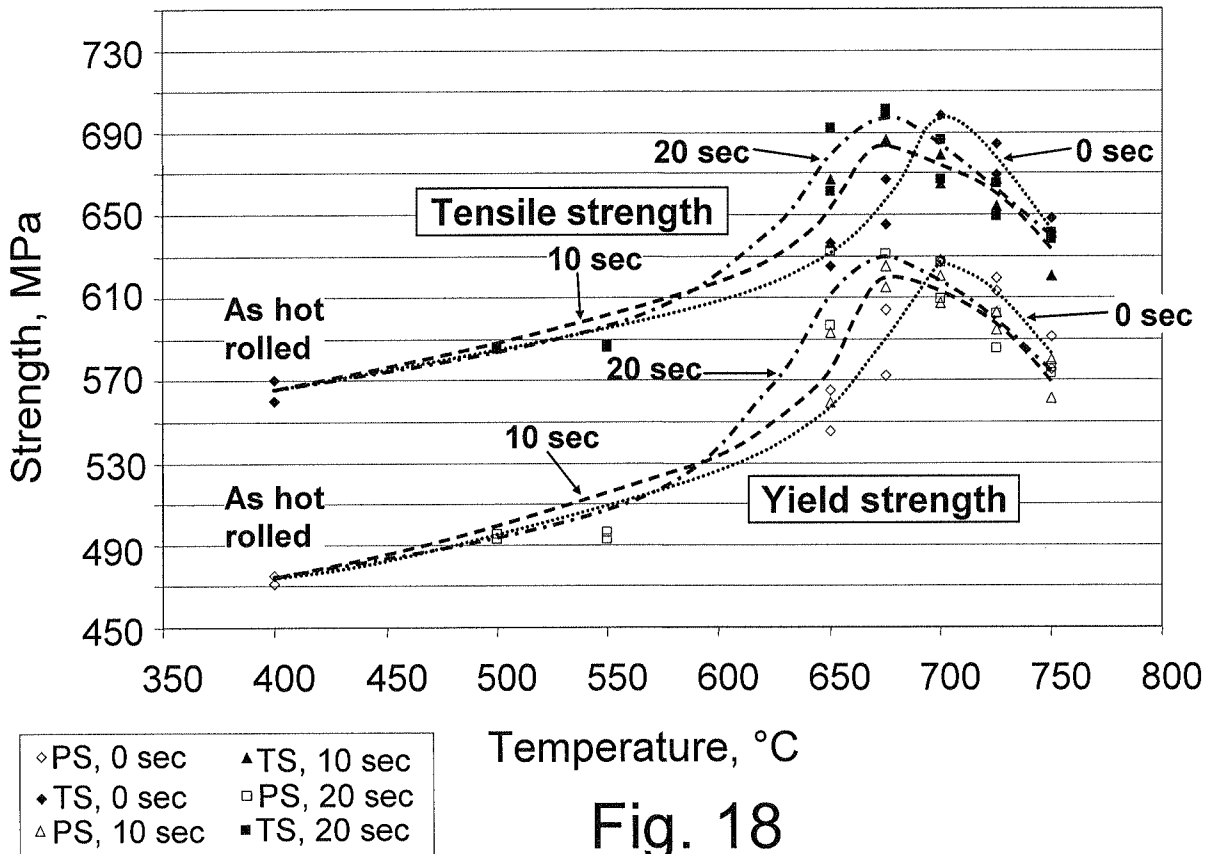

Fig. 18

Yield Strength vs Total Elongation of Hot Rolled and Age Hardened Galvanised Nb Microalloyed UCS

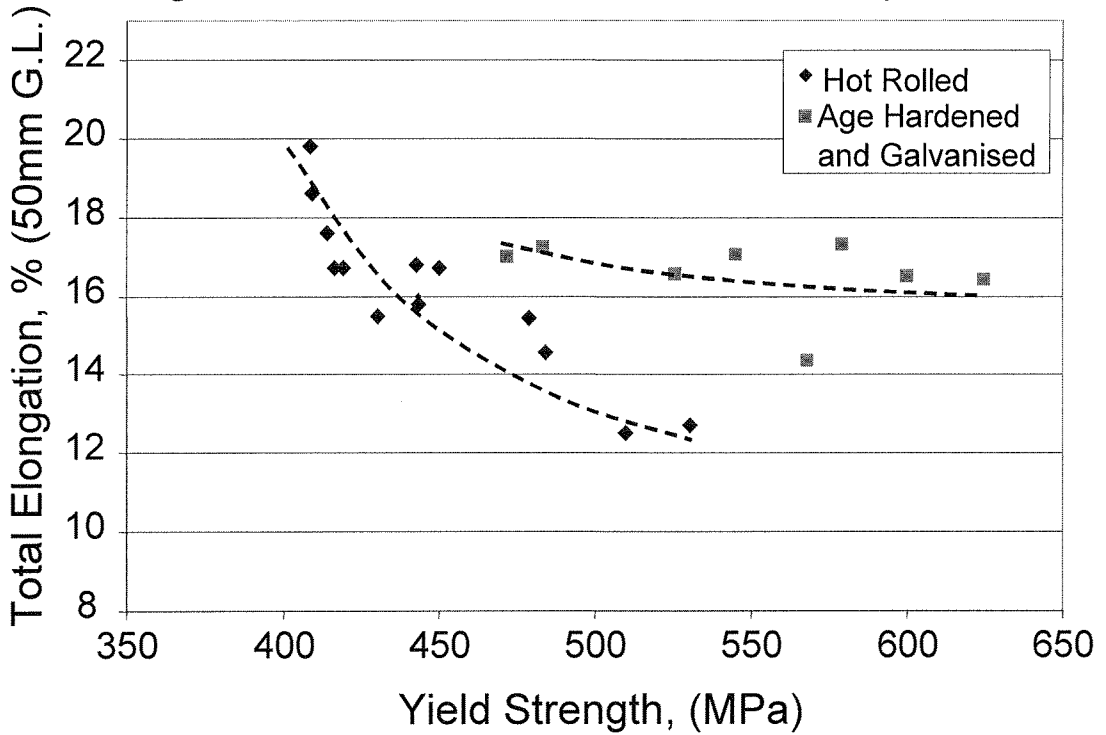

Fig. 19

Strength Increase for Galvanised 0.024% Nb Coil

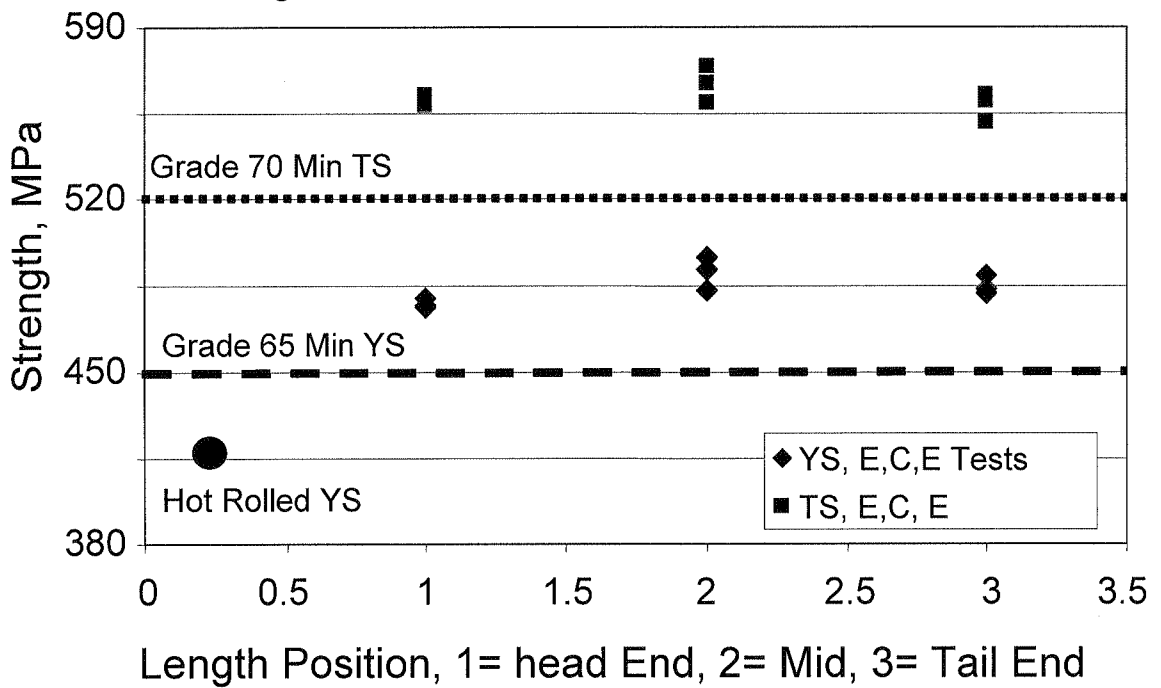

Fig. 20

Strength Levels Achieved with a 0.065% Nb steel in Hot Rolled and Age Hardened Condition

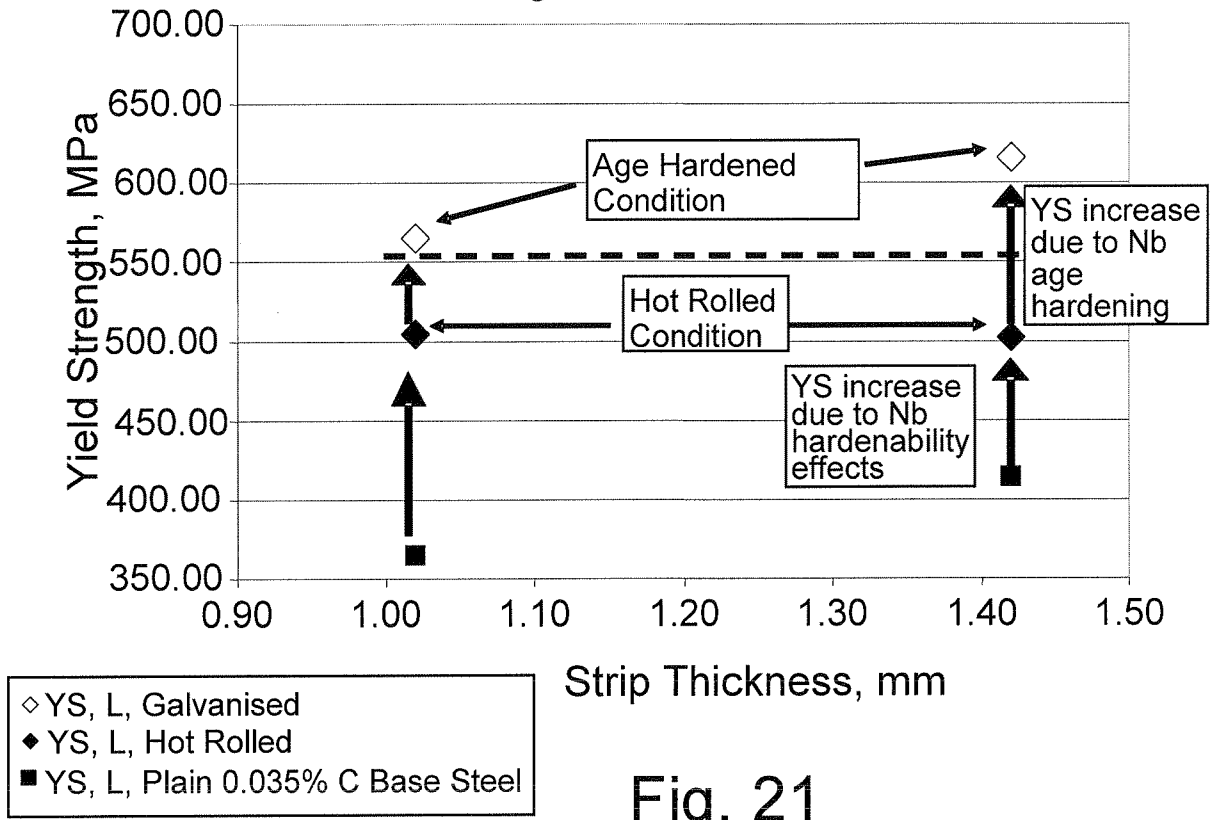

Fig. 21

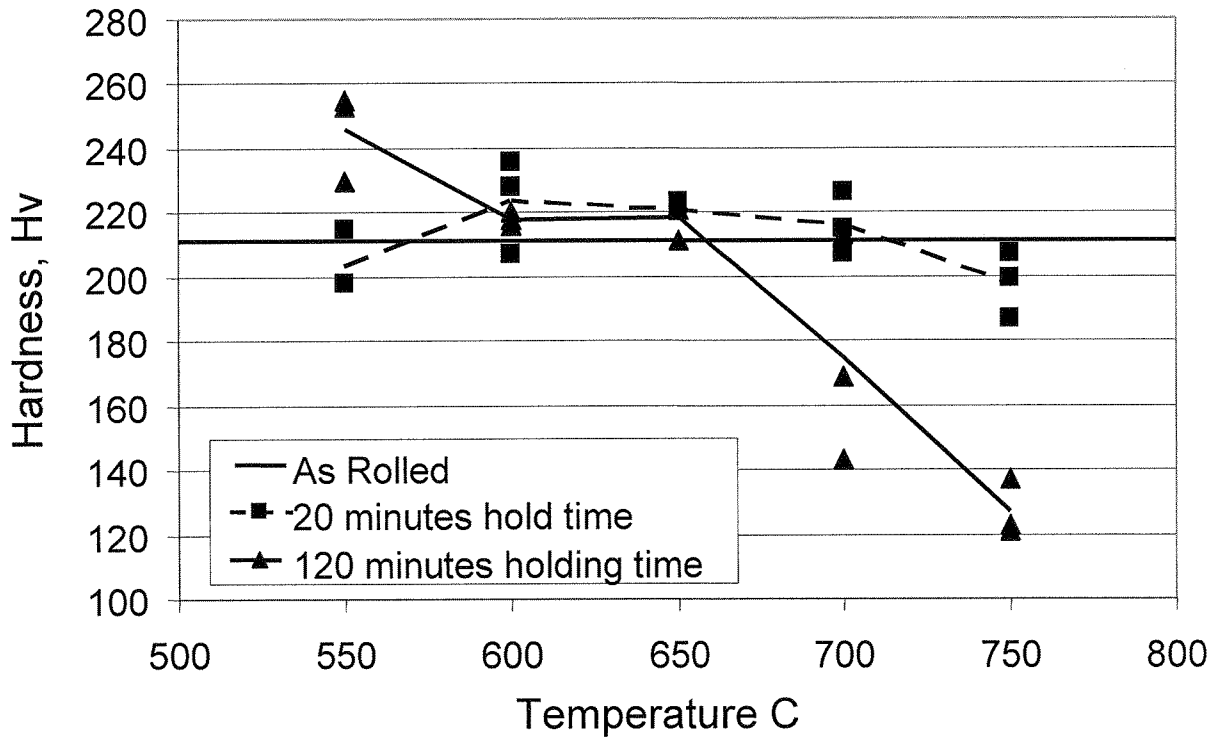

Fig. 22

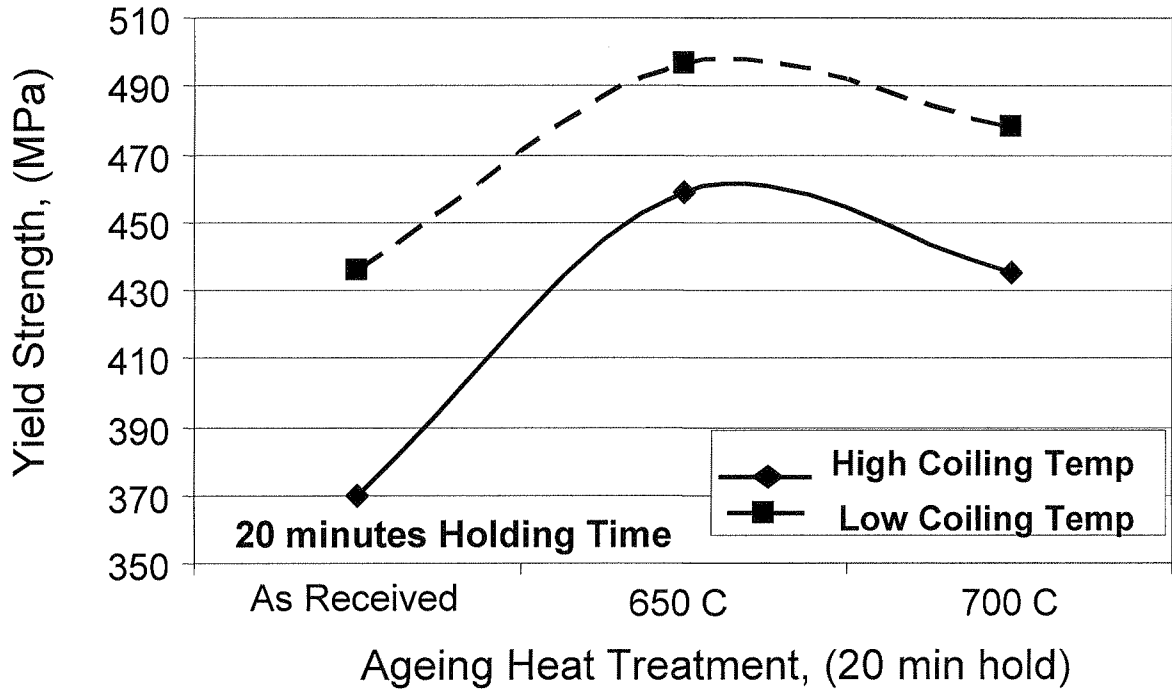
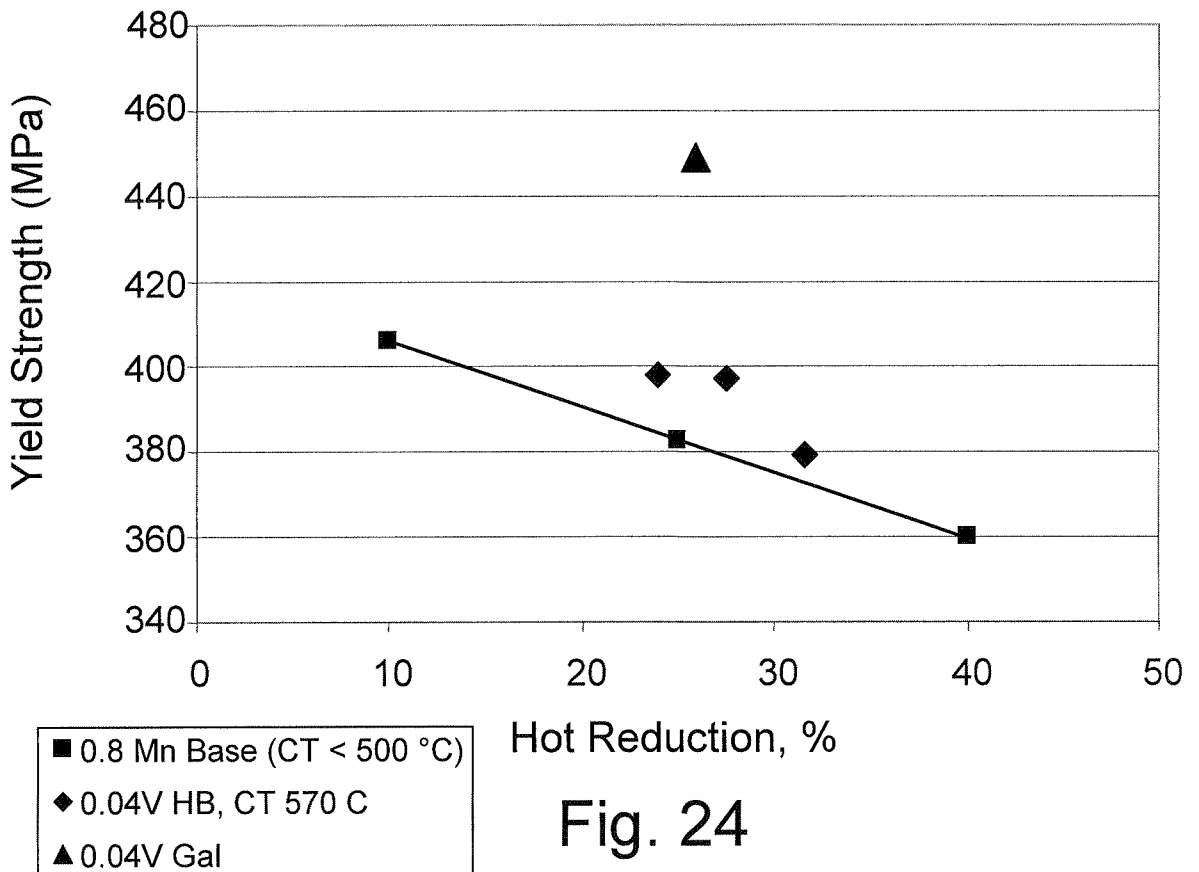

Fig. 23





Hot Reduction, %

Fig. 24

INTERNATIONAL SEARCH REPORT

International application No.
PCT/US2008/062776

A. CLASSIFICATION OF SUBJECT MATTER		
<i>B22D 11/06(2006.01)i, C22C 27/02(2006.01)i, B22D 11/124(2006.01)i</i>		
According to International Patent Classification (IPC) or to both national classification and IPC		
B. FIELDS SEARCHED		
Minimum documentation searched (classification system followed by classification symbols) IPC 8 B22D 11/22, C22D 38/00		
Documentation searched other than minimum documentation to the extent that such documents are included in the fields searched KR, JP: IPC as above		
Electronic data base consulted during the international search (name of data base and, where practicable, search terms used) eKIPASS(KIPO internal) "high strength", "thin cast strip", "bainite", "acicular ferrite", "Nb", "age hardening", "precipitation hardening"		
C. DOCUMENTS CONSIDERED TO BE RELEVANT		
Category*	Citation of document, with indication, where appropriate, of the relevant passages	Relevant to claim No.
X	US 6,502,626 B1 (Mascanzoni, Antonio et al) 07 January 2003 See Column 1, line51- Column 2, line31; Tables 1-8 and Figures 1-2	1-3,10-13,22-26,38,40, 41
Y		4-9,14,16-21
Y	US 6,663,725 B1 (Inoue, Tadashi et al) 16 December 2003 See Column 2, line30- Column 3, line 16; Tables 3,5,8,9 and Figure 3	4-9,14,16-21
A	US 6,818,073 B2 (Strezov, Lazar) 16 November 2004 See Abstract and Figure 1	1-44
<input type="checkbox"/> Further documents are listed in the continuation of Box C. <input checked="" type="checkbox"/> See patent family annex.		
* Special categories of cited documents: "A" document defining the general state of the art which is not considered to be of particular relevance "E" earlier application or patent but published on or after the international filing date "L" document which may throw doubts on priority claim(s) or which is cited to establish the publication date of citation or other special reason (as specified) "O" document referring to an oral disclosure, use, exhibition or other means "P" document published prior to the international filing date but later than the priority date claimed "T" later document published after the international filing date or priority date and not in conflict with the application but cited to understand the principle or theory underlying the invention "X" document of particular relevance; the claimed invention cannot be considered novel or cannot be considered to involve an inventive step when the document is taken alone "Y" document of particular relevance; the claimed invention cannot be considered to involve an inventive step when the document is combined with one or more other such documents, such combination being obvious to a person skilled in the art "&" document member of the same patent family		
Date of the actual completion of the international search 15 OCTOBER 2008 (15.10.2008)		Date of mailing of the international search report 15 OCTOBER 2008 (15.10.2008)
Name and mailing address of the ISA/KR  Korean Intellectual Property Office Government Complex-Daejeon, 139 Seonsa-ro, Seo-gu, Daejeon 302-701, Republic of Korea Facsimile No. 82-42-472-7140		Authorized officer SONG, Jay Wook Telephone No. 82-42-481-5520 

INTERNATIONAL SEARCH REPORT

Information on patent family members

International application No.

PCT/US2008/062776

Patent document cited in search report	Publication date	Patent family member(s)	Publication date
US 6,502,626 B1	07-01-2003	AT 313402 E	15-01-2006
		AU 744196 B2	21-02-2002
		BR 9810193 A	08-08-2000
		CA 2294333 A1	23-12-1998
		CN 1260740 A	19-07-2000
		CZ 293823 B6	18-08-2004
		DE 69832886 C0	26-01-2006
		EP 1007248 A1	14-06-2000
		ES 2255731 T3	01-07-2006
		HU 222856 B1	29-12-2003
		IT 1291931 B1	21-01-1999
		JP 13502974	06-03-2001
		KR 1020010013946	26-02-2001
		PL 186657 B1	27-02-2004
		RU 2212976 C2	27-09-2003
		SK 181499 A3	12-03-2001
		TR 9903146 T2	21-07-2000
UA 61113 C2	15-08-2000		
WO 9857767 A1	23-12-1998		
<hr/>			
US 6,663,725 B2	16-12-2003	EP 1143022 A1	10-10-2001
		JP 13152255	05-06-2001
		KR 1020010075195	09-08-2001
		WO 0120051 A1	22-03-2001
<hr/>			
US 6,818,073 B2	16-11-2004	AU 2001291499 B2	08-04-2002
		BR 200114338 A	09-12-2003
		CA 2420492 A1	04-04-2002
		CN 1458870	26-11-2003
		EP 1326723 A1	16-07-2003
		JP 16508942	25-03-2004
		KR 1020030064760	02-08-2003
		MX PA03001971 A	10-09-2004
		WO 0226422 A1	04-04-2002