

(19)



(11)

**EP 4 219 079 B1**

(12)

**EUROPEAN PATENT SPECIFICATION**

(45) Date of publication and mention of the grant of the patent:  
**14.08.2024 Bulletin 2024/33**

(51) International Patent Classification (IPC):  
**B25C 1/08 (2006.01) B25C 1/06 (2006.01)**  
**B25F 5/00 (2006.01)**

(21) Application number: **23173542.4**

(52) Cooperative Patent Classification (CPC):  
**B25C 1/08; B25C 1/06; B25F 5/006**

(22) Date of filing: **15.11.2019**

**(54) FASTENING TOOL WITH IMPROVED BALANCING**

BEFESTIGUNGSWERKZEUG MIT VERBESSERTEM AUSGLEICH

OUTIL DE FIXATION À ÉQUILIBRAGE AMÉLIORÉ

(84) Designated Contracting States:  
**AL AT BE BG CH CY CZ DE DK EE ES FI FR GB GR HR HU IE IS IT LI LT LU LV MC MK MT NL NO PL PT RO RS SE SI SK SM TR**

(72) Inventor: **SIMONIN, Jean-Luc**  
**Glenview 60025 (US)**

(43) Date of publication of application:  
**02.08.2023 Bulletin 2023/31**

(74) Representative: **HGF**  
**HGF Limited**  
**1 City Walk**  
**Leeds LS11 9DX (GB)**

(62) Document number(s) of the earlier application(s) in accordance with Art. 76 EPC:  
**19209315.1 / 3 822 028**

(56) References cited:  
**US-A1- 2014 346 213 US-A1- 2015 174 748**  
**US-B1- 6 223 966**

(73) Proprietor: **Illinois Tool Works Inc.**  
**Glenview IL 60025 (US)**

**EP 4 219 079 B1**

Note: Within nine months of the publication of the mention of the grant of the European patent in the European Patent Bulletin, any person may give notice to the European Patent Office of opposition to that patent, in accordance with the Implementing Regulations. Notice of opposition shall not be deemed to have been filed until the opposition fee has been paid. (Art. 99(1) European Patent Convention).

## Description

**[0001]** The present invention relates to a fastening tool, in particular, but not exclusively, to a fastening tool, for use in driving a fastener into a structure.

## Background

**[0002]** Fastening tools, such as, fuel cell nail guns, are commonly known. Patent application US2014/346213 described such fastening tool. However, a problem has existed with the balancing of fastening tools. That is, they are imperfectly balanced, which makes it difficult for the user to handle the tool and stabilise the tool for operation. In some instances, when the tool is being used, the recoil of the fastening tool causes an imbalance of the tool. In some extreme cases of imbalance, a forward or a backward momentum is produced when the tool is used, which causes stability problems and a difficulty to accurately use the tool. In order to balance a fastening tool, the centre of mass of the tool must be positioned in a way that it is at, or substantially at the point of the handle onto which the operator applies force. For some fastening tools, this is the actuation trigger of the fastening tool.

**[0003]** Shifting the centre of mass of the fastening tool may be achieved by simply moving relevant components of the fastening tool around or change the weight of one or more components. However, most tools are already designed to minimise the space used within the housing while maximising its functionality, so that it is not that straight forward to simply move one component to another location within the housing as the tool needs to remain useable and remain easy for the user to operate. For example, a battery should be in a location that allows quick and easy removal and installation. Also, the fastening tool should be designed in a way that improves the access to the battery, and which is balanced for stable use.

**[0004]** It would therefore be desirable to provide a fastening tool that can alleviate or mitigate one or more of the aforementioned problems. Particularly, it is an object of the invention to provide a fastening tool having an improved use and ease of use, and having an improved balance that facilitates stable operation.

**[0005]** The present invention provides at least one alternative to the fastening tools of the prior art.

## Summary of the Invention

**[0006]** In accordance with the present invention there is provided a fastening tool according to the appended claims.

**[0007]** According to an aspect of the present invention, there is provided a fastening tool for driving a fastener into a structure, comprising: a housing having a proximal end, a distal end and a longitudinal axis, and having a centre of mass arranged between the proximal end and the distal end; a handle, connected to the housing at the

proximal end and protruding from the housing in a direction substantially perpendicular to the longitudinal axis; a magazine carrier module, connected to the housing at the distal end and extending away from the housing in a direction substantially perpendicular to the longitudinal axis; and a battery housing, configured to retainingly receive a battery, operably coupled between respective distal ends of the handle and the magazine carrier module so as to provide a total centre of mass of the fastening tool that is substantially coinciding with a trigger member of the handle.

**[0008]** Thus, there is provided a fastening tool with an improved weight balance during use. More specifically, the battery housing and the battery are operably coupled between distal ends of the handle and the magazine carrier module. This aligns the total centre of mass of fastening tool with the trigger member. Therefore, when the user engages the trigger member, the hand of the user aligns with, or is coincident with the centre of mass of the fastening tool. This reduces the impact of tool recoil and reduces the difficulty of tool operation.

**[0009]** Moreover, by having the battery housing, and the battery retainingly received in the housing, operably coupled between respective distal ends of the handle and the magazine carrier module, the removal and attachment of the battery is more easily done. Therefore, it is made simpler and quicker to change battery. The location of the battery is more accessible to the user. This makes the fastening tool easier to operate. More specifically, the location of the battery between respective distal ends of the handle and magazine carrier module allows the battery to be gripped from both sides, in order to remove the battery.

**[0010]** Advantageously in some embodiments, the battery housing may comprise an opening at a distal end portion that is facing away from said housing. This is particularly beneficial because the battery can be removed from the battery housing in a direction away from the housing. Likewise, the battery can be inserted into the housing in a direction towards the housing. By moving the battery in this direction, the battery is not obstructed by the other components of the fastening tool during removal and insertion.

**[0011]** The battery housing comprises a dampening member provided between an internal wall of the battery housing and the battery during use. This is beneficial because the dampening member reduces the vibrations and noise during operation of the fastening tool.

**[0012]** Advantageously in specific embodiments, the battery housing comprises two opposing recesses at the distal end portion, configured to provide user access to the battery. This provides the advantage of providing additional grip for the user to engage with the battery, particularly to improve the ease of removing the battery, in order to change the battery, for example.

**[0013]** Advantageously in some embodiments, the battery housing is adapted to operably couple the battery with a controller. In some embodiments, the battery hous-

ing is adapted to operably couple the battery with a fuel cell. In some embodiments, the battery housing is adapted to operably couple the battery with an internal combustion engine. In this way, the battery housing allows electric power to be provided to any one of the controller, fuel cell and internal combustion engine.

**[0014]** Advantageously in some embodiments, the magazine carrier module is coplanar with the handle.

### Brief Description of the Drawings

**[0015]** Embodiments of the invention are now described, by way of example only, hereinafter with reference to the accompanying drawings, in which:

**Figure 1** illustrates a left side view of an example embodiment of the fastening tool of the present invention;

**Figure 2** illustrates a right side view of the fastening tool shown in Figure 1;

**Figure 3** illustrates a perspective view of the fastening tool shown in Figure 1; and

**Figure 4** shows a portion of the fastening tool with one side of the housing removed exposing the battery casing.

### Detailed Description

**[0016]** The described example embodiment relates to fastening tool and particularly a fastening tool for driving a fastener into a structure.

**[0017]** As used herein, the term "centre of mass" is used to describe the point which represents the average position of the matter within a system, weighted according to quantity of matter. For example, the centre of mass of the housing is the point representing the average position of matter within the housing. As another example, the total centre of mass of the fastening tool refers to the point representing the average position of matter in the fastening tool, weighted according to quantity of matter in each of the components or parts forming the fastening tool.

**[0018]** As used herein, the term "coincide" or "coincident" is used to describe a two or more bodies or shapes which has at least two common planes.

**[0019]** As used herein, the term "dampening member" is used to describe a structure that reduces the extent or amplitude of vibration.

**[0020]** As used herein, the term "distal" is used to describe the side that is away from the user when the fastening tool is in use.

**[0021]** As used herein, the term "end" is used to describe a location that is towards a boundary of a body. The term "end" may refer to a positional extreme. In some examples, "end" refers to a position relative to another.

For example, the proximal end of the housing refers to a location that is towards, or closer to the proximal side of the housing.

**[0022]** As used herein, the term "longitudinal axis" is used to describe an imaginary line extending along the length of the body or part.

**[0023]** As used herein, the term "opening" is used to describe a gap that allows passage or access.

**[0024]** As used herein, the term "proximal" is used to describe the side that is closer to the user when the fastening tool is in use.

**[0025]** Certain terminology is used in the following description for convenience only and is not limiting. The words 'right', 'left', 'lower', 'upper', 'front', 'rear', 'upward', 'down' and 'downward' designate directions in the drawings to which reference is made and are with respect to the described component when assembled and mounted. The words 'inner', 'inwardly' and 'outer', 'outwardly' refer to directions toward and away from, respectively, a designated centreline or a geometric centre of an element being described (e.g. central axis), the particular meaning being readily apparent from the context of the description.

**[0026]** Further, as used herein, the terms 'connected', 'attached', 'coupled', 'mounted' are intended to include direct connections between two members without any other members interposed therebetween, as well as, indirect connections between members in which one or more other members are interposed therebetween. The terminology includes the words specifically mentioned above, derivatives thereof, and words of similar import.

**[0027]** Further, unless otherwise specified, the use of ordinal adjectives, such as, "first", "second", "third" etc. merely indicate that different instances of like objects are being referred to and are not intended to imply that the objects so described must be in a given sequence, either temporally, spatially, in ranking or in any other manner.

**[0028]** Like reference numerals are used to depict like features throughout.

**[0029]** Referring to **Figures 1 to 3**, a fastening tool 1 is shown. The fastening tool 1 is provided with a housing 11. The housing 11 has a proximal end 11a, a distal end 11b and a longitudinal axis 5. The housing 11 is provided with an internal combustion engine 2 in this example. The internal combustion engine 2 contains a mixture of air and fuel, and an ignition, which results in a piston being propelled to drive a fastening member into a structure. The fastening tool 1 is provided with a handle 8. The handle 8 is connected to the housing 11 and protrudes from the housing 11 in a direction that is substantially perpendicular to the housing 11. In this particular example, the handle 8 slightly bends backwards towards the proximal end 11a of the housing 11. The handle 8 is gripped with the hand of the user to hold the fastening tool 1. The handle 8 has a trigger 9 mounted to it. The handle has a connection area 10 where the trigger 9 is located.

**[0030]** The fastening member is provided in a maga-

zine carrier module 3. The magazine carrier module 3 is provided at the distal end 11b of the housing 11. The magazine carrier module 3 is connected at the distal end 11b, to the housing and extends in a direction substantially perpendicular to the longitudinal axis 5 of the housing 11. In some examples, the magazine carrier module 3 is coplanar with the handle 8. The fastener member is supplied from the magazine carrier module 3 and is propelled by the piston through the tip guide 4, and into the structure. In this example, supplying the internal combustion engine 2 with fuel is done using an injection member such as, for example, a solenoid valve, from a cell of a combustible fuel. The housing 11 and components within the housing have a total centre of mass that is substantially located between the proximal end 11a and the distal end 11b.

**[0031]** In order to operate the tool, an electric power supply is provided. In this example, electric power is supplied using a battery 27 (see **Figure 4**). The battery 27 is provided and retained inside a battery housing 20. The battery housing 20 is attached in a place between the magazine carrier module 3 and the handle 8. As best seen from **Figure 1**, the battery housing 20 is coupled to a part of the handle 8 via fixings (not shown) received in fastening apertures 22. In this particular example, screws are received in the apertures 22 to hold the battery housing 20 in place. It is envisaged that other fixation means may be used to locate the battery housing 20. The battery housing 20 may additionally or alternative be coupled to the magazine carrier module 3 in a similar way. The battery housing 20 has a longitudinal axis that extends in a direction substantially perpendicularly to the longitudinal axis 5 of the housing 11. The longitudinal axis of the battery housing 20 is substantially aligned with the connection area 10. The longitudinal axis of the battery housing 20 is also substantially aligned with the trigger 9.

**[0032]** Thus, when the battery 27 is mounted inside the battery housing 20, the centre of mass of the fastening tool 1 is substantially coincident with the trigger 9, so as to balance the fastening tool 1 during use. It is particularly advantageous to have the longitudinal axis of the battery housing 20 aligned with the trigger so as to move the centre of the mass of the fastening tool 1 towards or at the trigger 9. This configuration of the battery housing 20 concentrates the centre of mass thereof towards the trigger 9.

**[0033]** Referring to **Figure 3**, the battery housing 20 is provided with at least one recess 30 at a distal end of the battery housing 20 opposite the housing 11. The recess 30 extends towards the side of the battery housing 20. The battery housing 20 in this example is provided additionally with another recess (not shown) at an opposite side relative to recess 30. The pair of opposing recesses 30 provides the user easy access to grip the battery 27 with two fingers. The user may engage the battery 27 at the recesses 30 to grip the battery 27 to remove it.

**[0034]** **Figure 4** shows the portion of the fastening tool 1 with one side of the housing 11 removed exposing the

battery casing 20. The fastening tool 1 has a housing 11 which is provided in two shell halves. **Figure 4** shows the fastening tool 1 having one of the shell halves removed. The battery housing 20 has a profile which corresponds to a dampening member 24 such that the dampening member 24 is retained inside the housing 11. The dampening member 24 is adapted to receive the battery 27 to protect the battery 27 from vibrations and shocks. The dampening member 24 is provided between an internal wall of the battery housing 20 and the battery 27. In this example, the dampening member 24 is provided with dampers 26 that provide protection to the battery 27 from vibrations and shocks. In some examples, a different number of dampers 26 is used. In some examples, the dampers 26 are provided in a different configuration. For example, a single damper 26 may be provided between an internal wall of the battery housing 20 and the battery 27 during use.

**[0035]** In this particular example, in use, the battery 27 is connected to a spark plug 28. In other examples, the battery 27 may be coupled to a controller, or sensors provided in the internal combustion engine, or any other component which requires an electrical power source.

**[0036]** Through the description and claims of this specification, the words "comprise" and "contain" and variations of them mean "including but not limited to", and they are not intended to (and do not) exclude other moieties, additives, components, integers or steps. Throughout the description and claims of this specification, the singular encompasses the plural unless the context otherwise requires. In particular, where the indefinite article is used, the specification is to be understood as contemplating plurality as well as singularity, unless the context requires otherwise.

**[0037]** The invention is defined in the claims.

## Claims

1. A fastening tool (1) for driving a fastener into a structure, comprising:

a housing (11), having a proximal end (11a), a distal end (11b) and a longitudinal axis (5), and having a centre of mass arranged between said proximal end (11a) and said distal end (11b);

a handle (8), connected to said housing (11) at said proximal end (11a) and protruding from said housing (11) in a direction substantially perpendicular to said longitudinal axis (5);

a magazine carrier module (3), connected to said housing (11) at said distal end (11b) and extending away from said housing (11) in a direction substantially perpendicular to said longitudinal axis (5); and

a battery housing (20), configured to retainingly receive a battery (27), operably coupled between respective distal ends of said handle (8)

and said magazine carrier module (3) so as to provide a total centre of mass of said fastening tool (1) that is substantially coinciding with a trigger member (9) of said handle (8),

**characterised in that** said battery housing (20) comprises a dampening member (24) provided between an internal wall of said battery housing (20) and the battery (27) during use.

2. A fastening tool (1) according to any preceding claim, wherein said battery housing (20) comprises two opposing recesses (30) at said distal end portion, configured to provide user access to the battery (27).
3. A fastening tool (1) according to any preceding claim, wherein said battery housing (20) is adapted to operably couple said battery (27) with any one of a controller, a fuel cell and an internal combustion engine (2).
4. A fastening tool (1) according to any preceding claim, wherein said magazine carrier module (3) is coplanar with said handle (8).

#### Patentansprüche

1. Befestigungswerkzeug (1) zum Eintreiben eines Befestigungselements in eine Struktur, aufweisend:

ein Gehäuse (11), das ein proximales Ende (11a), ein distales Ende (11b) und eine Längsachse (5) aufweist, und das einen Massenmittelpunkt aufweist, der zwischen dem proximalen Ende (11a) und dem distalen Ende (11b) angeordnet ist;

einen Griff (8), der mit dem Gehäuse (11) an dem proximalen Ende (11a) verbunden ist und von dem Gehäuse (11) in einer Richtung im Wesentlichen senkrecht zu der Längsachse (5) vorsteht;

ein Magazinträgermodul (3), das mit dem Gehäuse (11) an dem distalen Ende (11b) verbunden ist und sich von dem Gehäuse (11) in einer Richtung im Wesentlichen senkrecht zu der Längsachse (5) weg erstreckt; und

ein Batteriegehäuse (20), das konfiguriert ist, eine Batterie (27) sicher aufzunehmen, die funktionell zwischen jeweiligen distalen Enden des Griffs (8) und dem Magazinträgermodul (3) gekoppelt ist, um einen Gesamtmassenmittelpunkt des Befestigungswerkzeugs (1) bereitzustellen, der im Wesentlichen mit einem Auslöseelement (9) des Griffs (8) übereinstimmt,

**dadurch gekennzeichnet, dass** das Batteriegehäuse (20) ein Dämpfungselement (24) aufweist, das während des Gebrauchs zwischen einer Innenwand des Batteriegehäuses (20) und

der Batterie (27) bereitgestellt wird.

2. Befestigungswerkzeug (1) nach einem vorhergehenden Anspruch, wobei das Batteriegehäuse (20) zwei gegenüberliegende Ausnehmungen (30) an dem distalen Endabschnitt aufweist, die konfiguriert sind, dem Benutzer einen Zugang zu der Batterie (27) bereitzustellen.
3. Befestigungswerkzeug (1) nach einem vorhergehenden Anspruch, wobei das Batteriegehäuse (20) ausgelegt ist, die Batterie (27) mit einem von einer Steuerung, einer Brennstoffzelle und einem Verbrennungsmotor (2) funktionell zu koppeln.
4. Befestigungswerkzeug (1) nach einem vorhergehenden Anspruch, wobei das Magazinträgermodul (3) koplanar mit dem Griff (8) ist.

#### Revendications

1. Outil de fixation (1) pour l'enfoncement d'une fixation dans une structure, comprenant :

un logement (11), ayant une extrémité proximale (11a), une extrémité distale (11b) et un axe longitudinal (5), et ayant un centre de masse agencé entre ladite extrémité proximale (11a) et ladite extrémité distale (11b) ;

une poignée (8), connectée audit logement (11) au niveau de ladite extrémité proximale (11a) et faisant saillie à partir dudit logement (11) dans une direction sensiblement perpendiculaire audit axe longitudinal (5) ;

un module de support de magasin (3), connecté audit logement (11) sur ladite extrémité distale (11b) et s'étendant à l'écart dudit logement (11) dans une direction sensiblement perpendiculaire audit axe longitudinal (5) ; et

un logement de batterie (20), configuré pour recevoir de manière retenue une batterie (27), couplé de manière opérationnelle entre des extrémités distales respectives de ladite poignée (8) et dudit module de support de magasin (3) afin de fournir un centre de masse total dudit outil de fixation (1) qui coïncide sensiblement avec un élément de déclenchement (9) de ladite poignée (8),

**caractérisé en ce que** ledit logement de batterie (20) comprend un élément d'amortissement (24) fourni entre une paroi interne dudit logement de batterie (20) et la batterie (27) durant l'utilisation.

2. Outil de fixation (1) selon l'une quelconque des revendications précédentes, dans lequel ledit logement de batterie (20) comprend deux évidements

opposés (30) sur ladite partie d'extrémité distale, configurés pour fournir à l'utilisateur un accès à la batterie (27).

3. Outil de fixation (1) selon l'une quelconque des revendications précédentes, dans lequel ledit logement de batterie (20) est adapté pour coupler de manière opérationnelle ladite batterie (27) avec l'un quelconque parmi un dispositif de commande, une pile à combustible et un moteur à combustion interne (2). 5  
10
4. Outil de fixation (1) selon l'une quelconque des revendications précédentes, dans lequel ledit module de support de magasin (3) est coplanaire avec ladite poignée (8) . 15

20

25

30

35

40

45

50

55

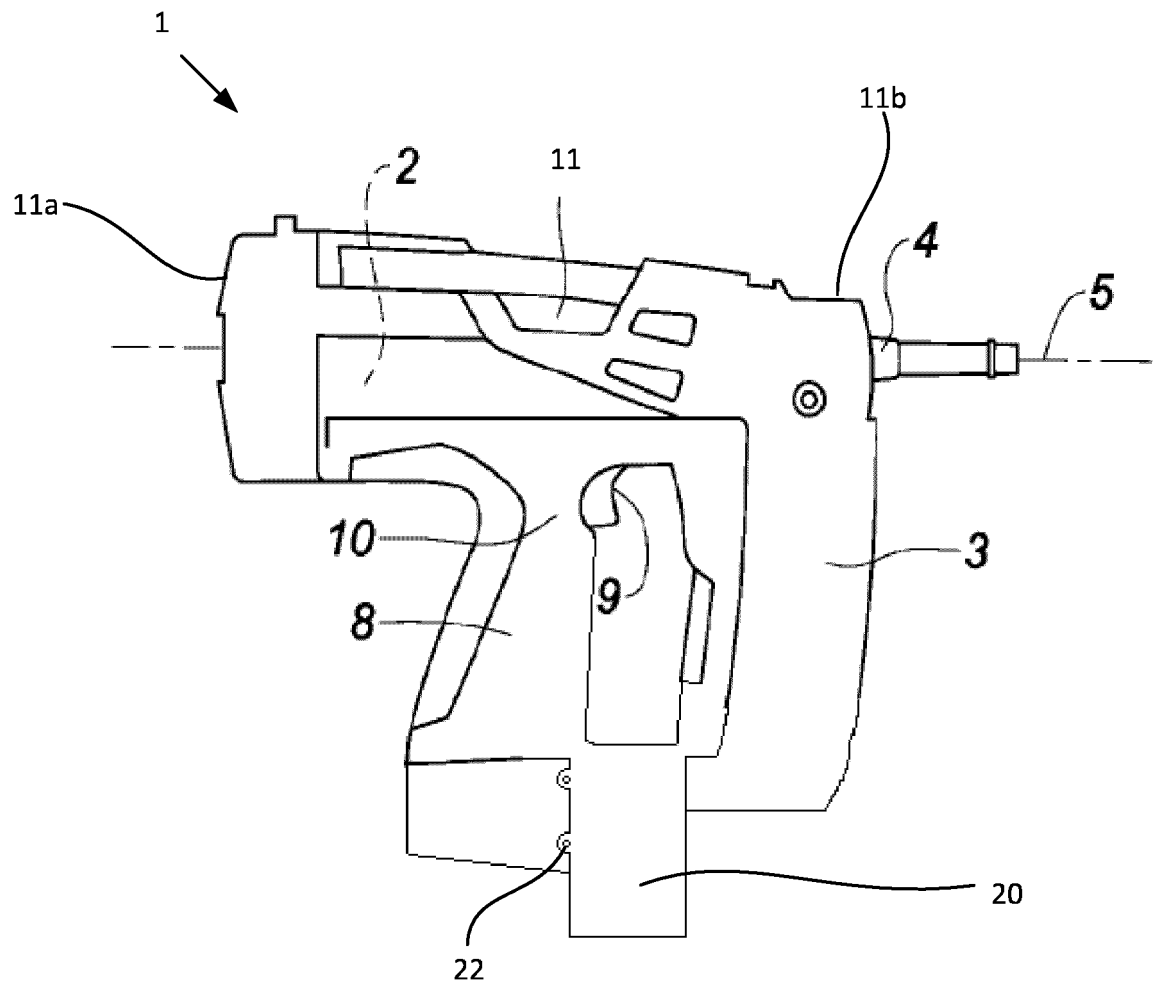

FIG. 1

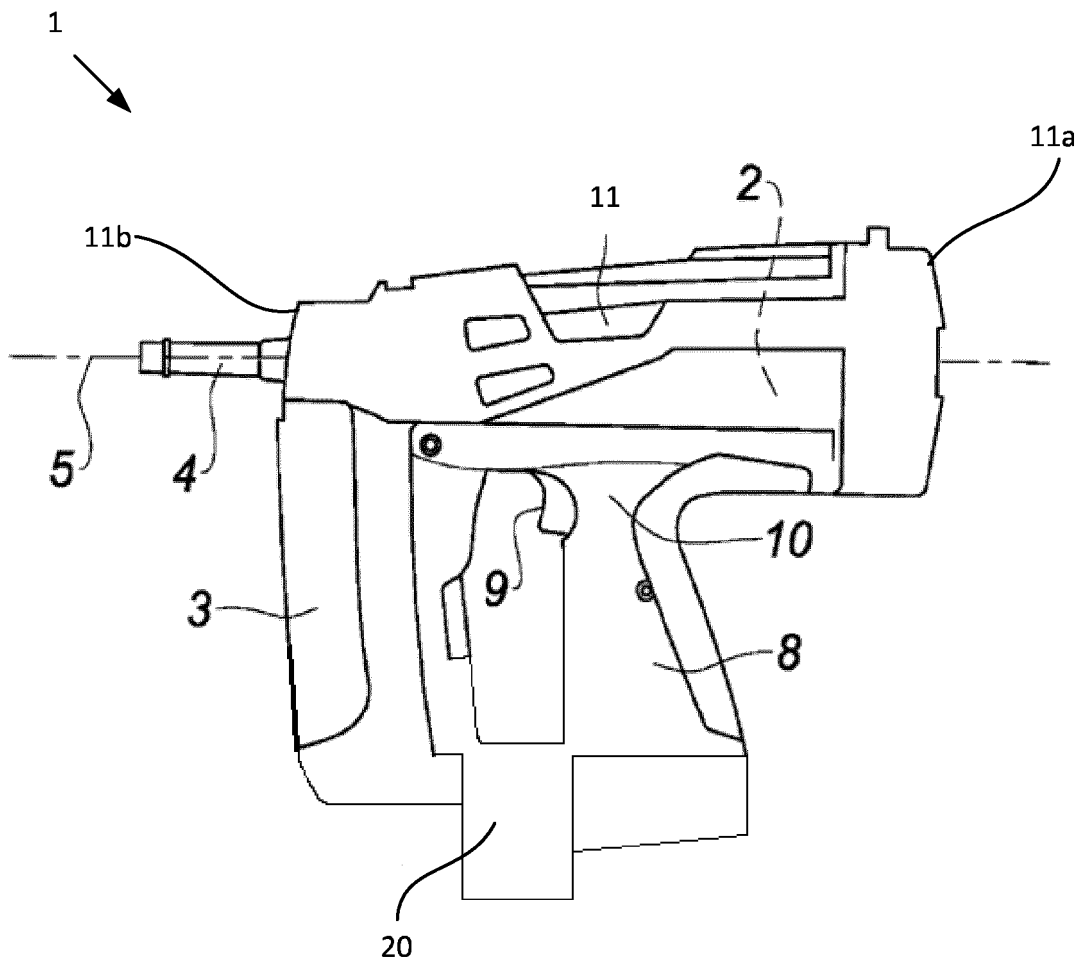

FIG. 2

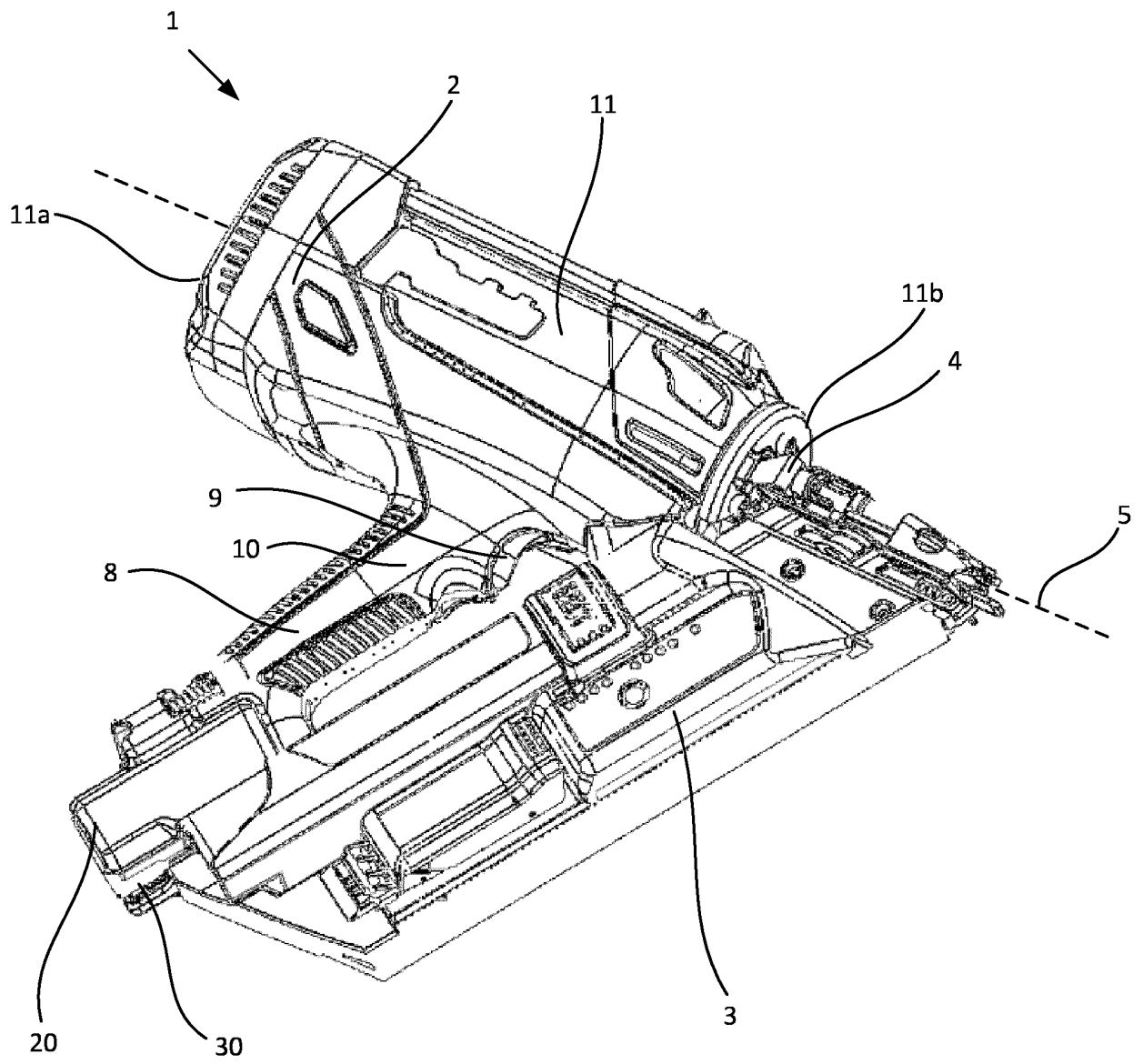

FIG. 3

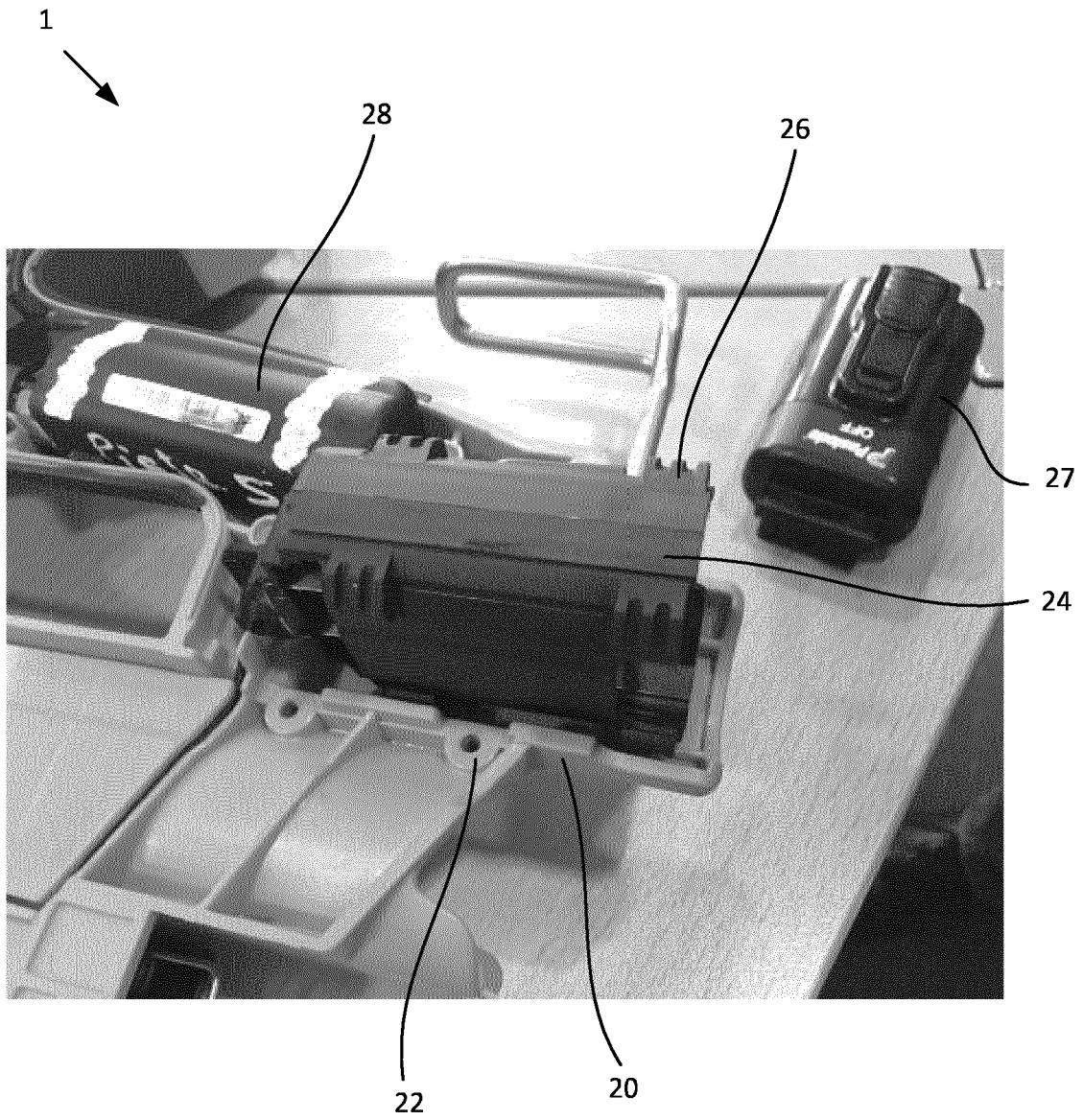

FIG. 4

**REFERENCES CITED IN THE DESCRIPTION**

*This list of references cited by the applicant is for the reader's convenience only. It does not form part of the European patent document. Even though great care has been taken in compiling the references, errors or omissions cannot be excluded and the EPO disclaims all liability in this regard.*

**Patent documents cited in the description**

- US 2014346213 A [0002]