



US 20040104231A1

(19) **United States**

(12) **Patent Application Publication**
Hassell et al.

(10) **Pub. No.: US 2004/0104231 A1**

(43) **Pub. Date: Jun. 3, 2004**

(54) **COLLAPSIBLE CONTAINER**

(52) **U.S. Cl. 220/6**

(76) Inventors: **Jon P. Hassell**, Atlanta, GA (US);
William P. Apps, Alpharetta, GA (US)

(57) **ABSTRACT**

Correspondence Address:
KONSTANTINE J. DIAMOND
4010 E. 26th st.
Los Angeles, CA 90023 (US)

A collapsible container has a base member and an end wall pivotably attached to the base member by a hinge mechanism for allowing the end wall to pivotably move between a folded position and an upright position. The end wall has lateral edges with latch members formed therein. Also included is a pair of opposed side walls each pivotably attached to the base member by a hinge mechanism for allowing the side walls to pivotably move between a folded position and an upright position. Each of the side walls includes an upper surface which is substantially beveled along its length, and a rear flanged portion having a latch receiver formed therein for receiving a respective latch member and for securing the container in an assembled position.

(21) Appl. No.: **10/677,745**

(22) Filed: **Oct. 1, 2003**

Related U.S. Application Data

(60) Provisional application No. 60/415,733, filed on Oct. 2, 2002.

Publication Classification

(51) **Int. Cl.⁷ B65D 6/16**

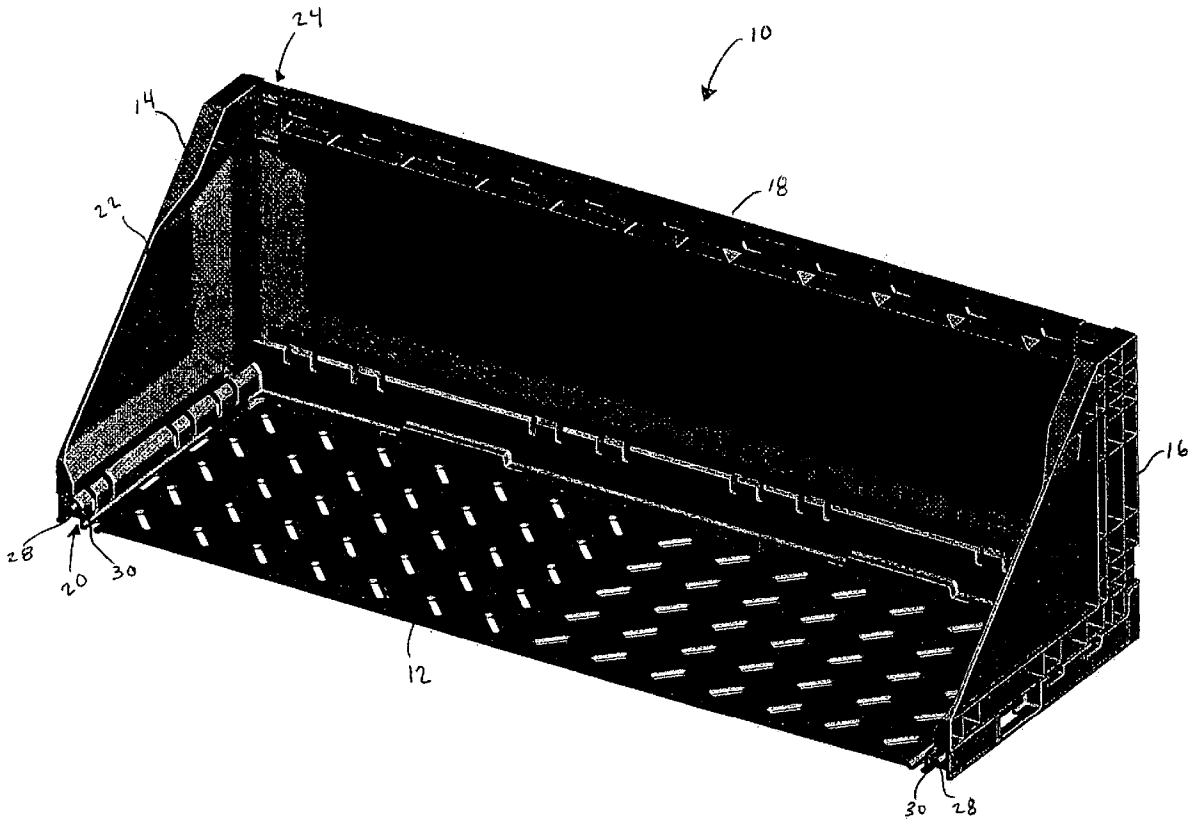

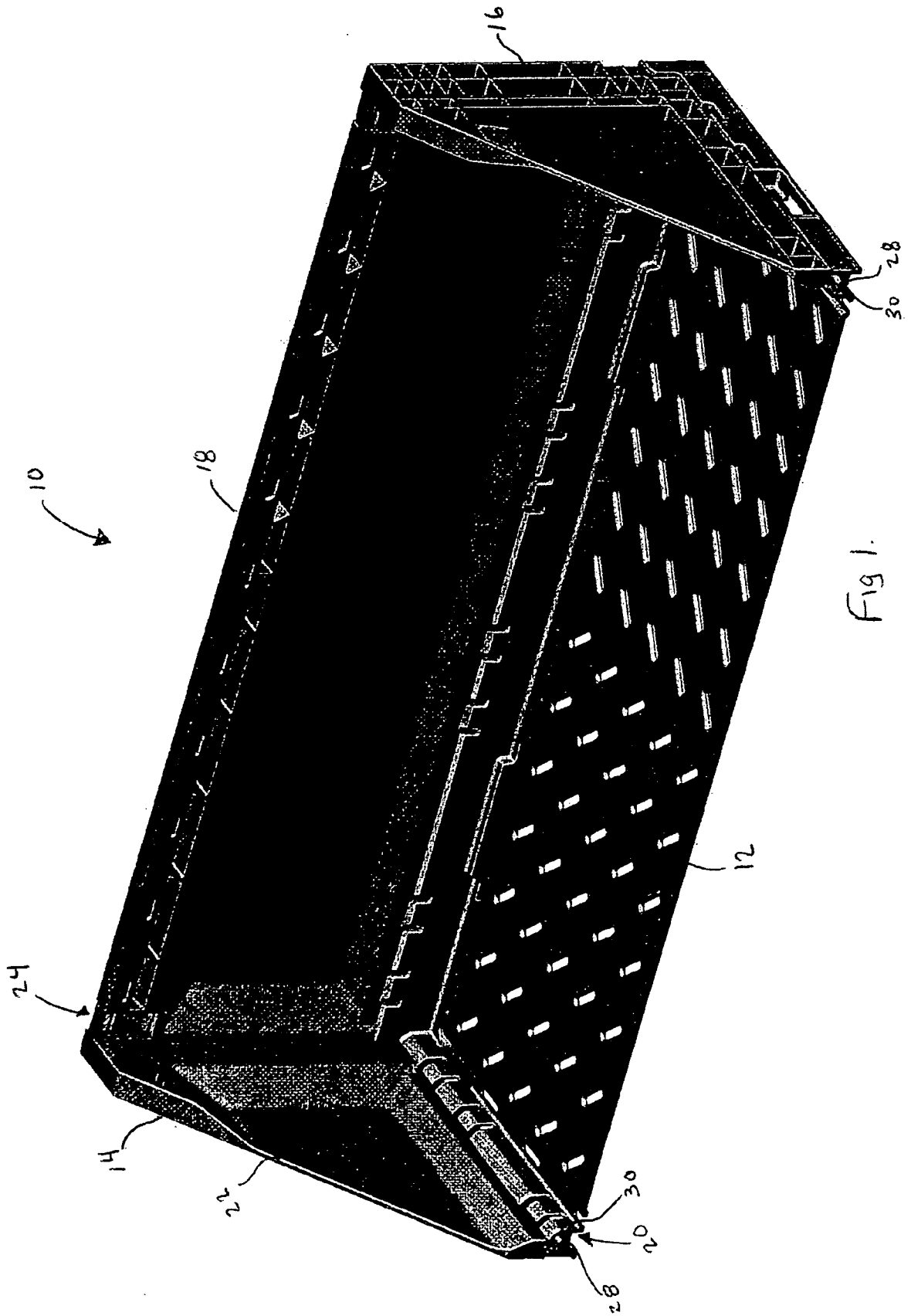

Fig. 1.

COLLAPSIBLE CONTAINER

CROSS-REFERENCE TO RELATED APPLICATIONS

[0001] This application claims the benefit of U.S. provisional application Serial No. 60/415,733 filed Oct. 2, 2002.

BACKGROUND OF THE INVENTION

[0002] 1. Field of the Invention

[0003] This invention relates to a collapsible container formed of plastic.

[0004] 2. Background Art

[0005] Collapsible containers may be formed of various materials. Many materials presently used, such as paperboard or cardboard, are typically one-piece die-cut members having multiple fold lines by which the container panels are folded. While such containers may be functional, the fold lines may not provide the strength or the durability required for certain applications. Moreover, many of these designs have panels which fold outwardly when not assembled, thereby requiring a larger surface area for storage when not in use. Further, such containers may be used in a display setting, such as in a grocery store. However, present collapsible containers may not provide the retail visibility into a container that may be desired by the manufacturers of the goods stored in the container.

[0006] Accordingly, there is a need for a collapsible container which is strong, has great durability, is compact when not in use, folds easily, and which provides visibility into the container for display purposes.

SUMMARY OF THE INVENTION

[0007] It is an object according to the present invention to provide a collapsible container which is strong, durable, portable, folds in a compact manner when not in use, and provides for visibility into the container for display purpose.

[0008] In keeping with the above objects, provided is a collapsible container having a base member and an end wall pivotably attached to the base member by a hinge mechanism for allowing the end wall to pivotably move between a folded position and an upright position. The end wall has lateral edges with latch members formed therein. Also included is a pair of opposed side walls each pivotably attached to the base member by a hinge mechanism for allowing the side walls to pivotably move between a folded position and an upright position. Each of the side walls includes an upper surface which is substantially beveled along its length, and a rear flanged portion having a latch receiver formed therein for receiving a respective latch member and for securing the container in an assembled position.

[0009] The above objects and other objects, features, and advantages of the present invention are readily apparent from the following detailed description of the best mode for carrying out the invention when taken in connection with the accompanying drawings.

BRIEF DESCRIPTION OF THE DRAWINGS

[0010] FIG. 1 is a perspective view of the collapsible container according to the present invention oriented in the assembled position; and

[0011] FIG. 2 is a perspective view of the container of FIG. 1, with one of the walls shown pivoted away from the upright position.

DETAILED DESCRIPTION OF THE PREFERRED EMBODIMENT(S)

[0012] FIG. 1 illustrates a collapsible container 10 according to the present invention. Container 10 is preferably formed of injection molded plastic. Container 10 includes a base member 12, a first pair of opposed side walls 14, 16 and an end wall 18. Walls 14, 16 and 18 are each pivotably attached to base member 12 by way of hinge mechanisms 20. As shown in FIG. 2, the hinge mechanisms 20 allow the walls to fold inwardly and rest upon base member 12 to provide for compact and efficient storage when not in use. The hinge mechanisms 20 allow the collapsible nature of the container to be durable and long lasting. The hinge mechanisms 20 illustrated herein provide for pivotal movement between the walls 14, 16, 18 and the base member 12, and may be one of various hinge designs known in the art that allows a separately folded wall member to pivotably attach to a separately formed base member 12. The hinge mechanism 20 includes a first hinge portion 28 extending downwardly from the walls 14, 16, 18, which is received by a hinge receiver 30 disposed along the periphery of base 12.

[0013] Moreover, it is noted that the end walls 14, 16 according to the present invention has an upper surface 22 which is beveled thus providing for visibility into the container 10, which is particularly helpful when the container is used in a retail setting, and when one desires to view the contents stored therein, such as jars and cans having labels. The angle of the end wall upper surface shown herein is approximately 45°, but may of course have any one of various ranges of angles, such as 30°-60°, for providing the desired visibility.

[0014] The container also includes a latch system 24 whereby end wall 18 has a latch member 26 which is received within the latch receiver 28 of the side walls 14, 16 for securely holding the container walls together when in an assembled position as in FIG. 1. Of course, the container may use any number of latch mechanisms known in the art. The latch system 24 is of the knock-down type, which is typically released from the latched position by applying force to end wall 18 sufficient to release the latch member 26 from the latch receiver 28, such that the wall will inwardly fold.

[0015] When desired, the container may be folded when not in use. If it is desired to transport the container having goods stored therein, the container may be strapped or otherwise secured so that the goods do not become separated from the container.

[0016] While embodiments of the invention have been illustrated and described, it is not intended that these embodiments illustrate and describe all possible forms of the invention. Rather, the words used in the specification are words of description rather than limitation, and it is understood that various changes may be made without departing from the spirit and scope of the invention.

What is claimed is:

1. A collapsible container comprises:

a base member;

an end wall pivotably attached to the base member by a hinge mechanism for allowing the end wall to pivotably move between a folded position and an upright position, the end wall having lateral edges with latch members formed therein; and

a pair of opposed side walls each pivotably attached to the base member by a hinge mechanism for allowing the side walls to pivotably move between a folded position and an upright position, wherein each of the side walls includes an upper surface which is substantially beveled along its length, and a rear flanged portion having a latch receiver formed therein for receiving a respective latch member and for securing the container in an assembled position.

* * * * *