

(19) **DANMARK**

(10) **DK/EP 3551497 T3**



Patent- og  
Varemærkestyrelsen

(12) **Oversættelse af  
europæisk patentskrift**

- 
- (51) Int.Cl.: **B 60 P 3/12 (2006.01)** **B 66 C 23/00 (2006.01)** **B 66 C 23/18 (2006.01)**  
**B 66 C 23/70 (2006.01)** **B 66 C 23/78 (2006.01)** **B 66 C 23/86 (2006.01)**
- (45) Oversættelsen bekendtgjort den: **2020-12-07**
- (80) Dato for Den Europæiske Patentmyndigheds bekendtgørelse om meddelelse af patentet: **2020-09-23**
- (86) Europæisk ansøgning nr.: **18808542.7**
- (86) Europæisk indleveringsdag: **2018-02-13**
- (87) Den europæiske ansøgnings publiceringsdag: **2019-10-16**
- (86) International ansøgning nr.: **TR2018050054**
- (87) Internationalt publikationsnr.: **WO2019004958**
- (30) Prioritet: **2017-03-16 TR 201704022**
- (84) Designerede stater: **AL AT BE BG CH CY CZ DE DK EE ES FI FR GB GR HR HU IE IS IT LI LT LU LV MC MK MT NL NO PL PT RO RS SE SI SK SM TR**
- (73) Patenthaver: **Erkin Ismakinalari Insaat Sanayi Ithalat Ihracat Ticaret Pazarlama Limited Sirketi, Fatih Mahallesi , Denizli Karayolu Caddesi 76 Z01 , Kuyucak, Nazilli/Aydin, Tyrkiet**
- (72) Opfinder: **ERKIN, Bahtiyar, Denizli Asfalt Uzeri, Kuyucak, Aydin, Tyrkiet**
- (74) Fuldmægtig i Danmark: **Gotapatent AB, Box 3127, S-550 03 Jönköping, Sverige**
- (54) Benævnelse: **KRANVOGN SOM KAN ROTERE ET KØRETØJ I LUFTEN**
- (56) Fremdragne publikationer:  
**EP-A1- 1 707 529**  
**CN-A- 105 480 140**  
**US-A- 4 515 282**  
**US-A- 5 387 071**  
**US-A- 6 092 975**  
**US-A1- 2011 150 613**



# DESCRIPTION

## The Related Art

**[0001]** This invention relates to rotator tow truck capable to lift and rotate in the air the vehicles which are involved in accidents, tug, tow and lift high capacity weights by means of rope towing arms structured on extension arm.

## The Prior Art

**[0002]** The vehicles becoming unusable because of an accident or travel mechanism not working for any other reasons, are towed by a rotator tow truck having different designs in the related art. However, rotator tow truck already in use, fail to display the desired success for towing and rotating the tipped over vehicles under various field conditions.

**[0003]** The patent application US5387071 discloses a recovery vehicle according to the preamble of claim 1. However, it comprises one upper towing rope with its correspondent upper towing winch and one lower towing rope with its correspondent lower towing winch. This document fails to disclose several ropes and correspondent winches in order to improve the manoeuvrability of the rescued vehicle.

**[0004]** The patent application numbered US7683564 discloses a telescopic crane system comprising a towing hook on the end and an embodiment that can be opened to enable the towing hook to reach a structure or a vehicle at a far distance. Telescopic body is supported by hydraulic piston which, provides knuckle motion to telescopic body, to main body. However, the patent numbered US7683564 does not have capability and technical characteristic to provide access to a vehicle falling in a hole or wild terrain at a far distance.

**[0005]** The system disclosed under patent application numbered US6092975 comprising a fixed body secured onto bottom having outrigger structure and carrying arm system conducting rotary movement on the main body. Rotary moving carrying arm system is supported by rope and tying to vehicle by a single rope and taking the vehicle from the terrain where it has fallen, by means of a single rope is provided. However, the invention numbered US6092975 is not capable to rotate the vehicle having accident and tow it from remote distance. It can perform short distance towing and lifting.

**[0006]** The application numbered US4790710 discloses an embodiment comprising a carrying extending arm having hook at the end and an embodiment moving the arm by means of a piston.

**[0007]** In addition, outriggers are used in order to prevent tip over of cranes of which weight

center changes during load carrying task. Outriggers are extended from the body and stabilize the changing weight center of the crane. This extension motion performed outward from body may cause problems such as stuck into obstacles on road side such as barrier bars. For that reason, either the crane cannot approach as required or experiences risk of tip over because outriggers are not opened as required.

**[0008]** As a result, existence of need for cranes capable to lift up and rotate towed vehicles, to approach to the related area as much as possible despite any obstacles by means of motions on vertical and horizontal axis and inadequacy of existing solutions have necessitated improvement in the related art.

### **Purpose of the Invention**

**[0009]** The present invention relates to tow trucks meeting the needs mentioned above, eliminating some disadvantages and providing some additional advantages.

**[0010]** The purpose of the rotator tow truck disclosed under the invention is to rotate the vehicle in air after lifting up and by means of independent motions of two rope-like towing members located on upper and lower parts of extension arm and thus transfers the vehicle to the desired place in the desired position. Any incidents can be addressed by means of such one crane. Operation period is short and needed labor is low.

**[0011]** Another purpose of the invention is to provide bending of the extension arm up to 40 degrees angles in respect to the plane where crane is, by help of hydraulic piston controlled joint where extension arm is connected, and thus enable it to access places on lower levels. Thus scope of range is increased significantly without need for higher capacity cranes.

**[0012]** Another purpose of the invention is to provide approach of the crane to incident site as close as possible without stuck into any obstacles such as barrier bars, by help of outriggers enabled to step on the ground perpendicularly after rotation on axis perpendicular to ground and opened and then lowered down. This provides advantages in respect to mobility.

**[0013]** In order to achieve the above purposes in the broadest way, a rotator tow truck capable to lift up and rotate towed vehicles in the air, to approach to the related site as much as possible, despite any obstacles, by means of motions on vertical and horizontal axis has been developed. The rotator tow truck comprises a body, main carrier fixed onto the body via rotating system and capable to rotate around vertical axis, main arm connected to the main carrier and capable to move up and down by help of lifting piston, extension arm connected to main arm via joint, having telescopic structure with length adjustability by help of extension piston and capable to move up and down by help of straightening piston, two upper towing members located on upper part of extension arm, driven independent of each by upper driving components and providing lifting and lowering the vehicles via extension arm, two lower towing members located on lower part of extension arm, driven independently by lower driving

components and providing lifting and lowering the vehicles on extension arm, an opening arm capable to rotate around vertical axis by help of vertical joint providing connection to the body, a vertical outrigger capable to rotate around horizontal axis by help of horizontal joint providing connection to opening arm.

**[0014]** The structural and characteristics features of the invention and all advantages will be understood better in detailed descriptions with the figures given below and with reference to the figures, and therefore, the assessment should be made taking into account the said figures and detailed explanations.

**Brief Description of the Drawings**

**[0015]** In order to make the embodiment and additional members being subject of the present invention as well as the advantages clearer for better understanding, it should be assessed with reference to the following described figures.

Figure 1 is general view indicating status of rotator tow truck when standby without truck.

Figure 2 is general view indicating the position when the tow truck rotator lifts up a vehicle at low level.

Figure 3 is general view indicating the position when the tow truck rotator rotates in air a vehicle at low level.

Figure 4 is general view indicating the position when the tow truck rotator tows another vehicle.

Figure 5 is general view indicating the position when the tow truck rotator pulls and tows another vehicle from where it is.

**Part References**

10	Rotator Tow Truck	45	Extension booms
11	Lower chassis	45a	Upper part of extension booms
11a	Lower chassis side part	45b	Lower part of extension booms
20	Lifting arm	46	Extension cylinders
21	Towing arm mechanism	47	Upper towing ropes
22	Lifting arm cylinder	48	Upper towing winches
23	Lifting arm towing winch	49	Lower towing ropes
30	Vertical Outrigger	50	Lower towing winches
31	Horizontal joint	51	Load axis alignment
32	Main Boom of Cross-tap Stabilizer	52	Knuckle
33	Vertical joint	53	Load axis alignment roller
34	Angular Rear Outrigger	54	Lower distance adjustment roller

35	Upper chassis	55	Direction roller
40	Slewing Ring system	90	Vehicle
41	Main body	A	In-air rotation movement
42	Lifting cylinder	x	Vertical axis
43	Main boom	y	Horizontal axis
44	Articulating Cylinder		

### Detailed Description of the Invention

**[0016]** The invention comprises at least a main body (41) comprising a lower chassis (11) and connected to the lower chassis (11) via a Slewing Ring system (40) and capable to rotate around vertical axis (x), an upper chassis (35), at least a main boom (43) connected to the main body (41) and capable to move up and down by means of lifting cylinder (42). Besides that, it discloses a rotator tow truck (10) comprising at least an extension booms (45) connected to the main boom (43) via an knuckle (52), capable to move up and down by help of an angle articulating cylinder (44) and telescopic structure allowing length adjustment by help of extension cylinders (46).

**[0017]** The invention relating to the rotator tow truck (10), differently from existing embodiments, in respect to novelty, comprises at least two upper towing ropes (47) located on the upper part of extension booms (45a) of the extension booms (45), driven independently by means of the upper towing winches (48) and providing lifting and lowering the vehicles (90) by means of the extension booms (45). The upper towing rope (47) directs the load axis alignment roller (53). In addition to that, the rotator tow truck (10) comprises at least two lower towing ropes (49) located on the lower part of extension booms (45b) of the extension booms (45), driven independently by means of the lower towing winches (50) and providing lifting and lowering the vehicles (90) by means of the extension booms (45).

**[0018]** The extension booms (45) of the developed rotator tow truck (10) can bend up to 40 degrees as shown in Figure 2 due to its knuckle (52) structure and can even tow the vehicles (90) from lower levels. The upper towing ropes (47) and the lower towing ropes (49) are connected to the vehicle (90) from different points and are moved independent of each other by means of the upper towing winches (48) and the lower towing winches (50) respectively and in-air rotation movement (A) of the vehicle (90) is provided. Said motion can be seen in Figure 3. direction roller (55) are housed in said knuckle (52) area.

**[0019]** The upper towing ropes (47) and the lower towing ropes (49) preferably comprising steel rope material and providing pulling and in-air rotation movement (A) of vehicle (90), are supported by Load axis alignment (51). The Load axis alignment (51) also provide shifting direction of the upper towing ropes (47) and the lower towing ropes (49). Thus their movement

in different directions is possible.

**[0020]** The lifting cylinder (42), the angle Articulating Cylinder (44) and the extension cylinders (46) driving all axis motions of the extension booms (45) which is the main functional factor of the rotator tow truck (10), are hydraulic based operated.

**[0021]** Another characteristic of the disclosed rotator tow truck (10) making it distinguished, is that it can approach to the place where the vehicle (90) to be towed is, as close as possible. For this, the main boom of cross-tap stabilizer (32) capable to rotate around the vertical axis (x) by means of the vertical joint (33) providing connection to the lower chassis (11) and the vertical outrigger (30) capable to rotate around the horizontal axis (y) by means of the horizontal joint (31) providing connection to main boom of cross-tap stabilizer (32) function. In the preferred embodiment as shown in Figure 3, one main boom of cross-tap stabilizer (32) is located on the lower chassis side parts (11a) of the lower chassis (11). Thus weighing centres varying from both sides can be met. Similarly, one angular rear outrigger (34) on each lower chassis side parts (11a) of the lower chassis (11) helps the rotator tow truck (10) to remain in balance.

**[0022]** The rotator tow truck (10) also comprises at least a towing arm mechanism (21) providing connection of vehicles (90) to the lower chassis (11) and towing of them and at least a lifting arm (20) comprising a lifting arm cylinder (22) providing up and down movements of the towing arm mechanism (21). The lifting arm (20) also comprises a lifting arm towing winch (23). Figure 4 shows a general view of the rotator tow truck (10) in the position when it tows a vehicle (90). The rotator tow truck (10) not only tows the vehicles (90) from accident site but also tows and transports them.

**[0023]** With the knuckle (52) structure, the rotator tow truck (10) capable to tow vehicles (90) from lower levels, to make indefinite rotations by help of the Slewing Ring system (40) and having capacity to lift 40 tons at 3 meters has been developed. It comprises total 4 towing hoists, namely, two upper towing winches (48) and 2 lower towing winches (50). The capacity of two of them is 20 tons while capacity of other two is 10 tons. By help of them, the vehicle (90) involved in accident or tilted over to one side can be hoisted and rotated or towed directly as shown in Figure 5.

**[0024]** During towing and rotating operations, firstly, the main boom of cross-tap stabilizer (32), the vertical outriggers (30) and the angular rear outriggers (34) are opened together and the rotator tow truck (10) is put in balance. Then the Slewing Ring system (40), the lifting cylinder (42), the angular Articulating Cylinder (44) and extension cylinders (46) are moved and facing the extension booms (45) in correct position and distance to the vehicle (90) to be towed is provided. Then depending on the operation to be performed, the related ones of the upper towing winches (48) and the lower towing winches (50) are started and the upper towing ropes (47) and the lower towing ropes (49) are moved and towing and straightening the vehicle (90) is provided. After this stage, the vehicle (90) is lowered onto ground or the towing arm mechanism (21) is connected. Knuckled extension booms (45) after operation takes its place

on the lower chassis (11) of the rotator tow truck (10) and balanced distribution of weight is provided. The lower towing ropes (49) are associated with the lower distance adjustment roller (54) and distanced by use of these reels.

## **REFERENCES CITED IN THE DESCRIPTION**

This list of references cited by the applicant is for the reader's convenience only. It does not form part of the European patent document. Even though great care has been taken in compiling the references, errors or omissions cannot be excluded and the EPO disclaims all liability in this regard.

### **Patent documents cited in the description**

- US5387071A [0003]
- US7683564B [0004] [0004]
- US6092975A [0005] [0005]
- US4790710A [0006]

## KRANVOGN SOM KAN ROTERE ET KØRETØJ I LUFTEN

PATENTKRAV

- 5        1. Kranvogn med roterende funktion (10) omfattende
- et nedre primært understel (11);
  - mindst et primært karosseri (41) forbundet til det nævnte  
10        nedre understel (11) via et drejekrans system (40) og  
       roterende omkring den vertikale akse (x),
  - mindst en primær bom (43) forbundet til det nævnte  
15        primære karosseri (41), og som kan bevæges op og ned ved  
       hjælp af en løftecylinder (42),
  - mindst en udvidelsesbom (45) forbundet til nævnte primære  
20        bom (43) via en styrespindel (52), som kan bevæges op og  
       ned ved hjælp af en ledcylinder (44), og som tillader  
       justeringer i længden ved hjælp af forlængelsescylindre  
       (46),
- og det er kendetegnet ved at omfatte
- 25        -        øvre slæbetov (47) placeret på nævnte udvidelsesbomme  
       (45), som kører uafhængigt af hinanden ved hjælp af de  
       øvre trækspil (48) og forbundet til køretøjet (90),
  - nedre slæbetov (49) placeret på nævnte udvidelsesbomme  
30        (45), som køre uafhængigt af hinanden ved hjælp af nedre  
       trækspil (50) og forbundet til køretøjet (90).
2. Kranvognen med roterende funktion (10) i henhold til krav 1  
35        og den er kendetegnet ved at omfatte mindst en justerbar  
       lastakse (51), som muliggør retnings skift af og  
       understøttelse af nævnte øvre slæbetov (47) og/eller nedre  
       slæbetov (49).
3. Kranvognen med roterende funktion (10 ) i henhold til krav 1  
40        og den er kendetegnet ved at omfatte mindst to øvre slæbetov  
       (47) placeret på den øvre del af udvidelsesbommene (45a) på  
       nævnte udvidelsesbomme (45).
4. Kranvognen med roterende funktion (10) i henhold til krav 1  
45        og den er kendetegnet ved at omfatte mindst to nedre slæbetov  
       (49) placeret på den nedre del af udvidelsesbommene (45b) på  
       nævnte udvidelsesbomme (45)
5. Kranvognen med roterende funktion (10) i henhold til krav 1  
50        og den er kendetegnet ved, at nævnte øvre slæbetov (47)  
       og/eller nedre slæbetov (49) er reb.

6. Kranvognen med roterende funktion (10) i henhold til krav 1 og den er kendetegnet ved, at nævnte løftecylinder (42) og/eller ledcylinder (44) og/eller forlængelsescylindere er hydrauliske.
- 5
7. Kranvognen med roterende funktion (10) i henhold til krav 1 og den er kendetegnet ved at omfatte
- 10 - mindst en primær bom med krydstap stabilisator(32), der kan rotere om den vertikale akse (x) ved hjælp af et vertikalt led (33) , som sørger for forbindelse til det nedre understel (11),
  - 15 - mindst et vertikalt støtteben (30), som kan rotere om den horisontale akse (y) ved hjælp af et horisontalt led (31), som sørger for forbindelse til den nævnte primære bom med krydstap stabilisator (32).
8. Kranvognen med roterende funktion (10) i henhold til krav 7 og den er kendetegnet ved, at mindst en af nævnte primære bomme med krydstap stabilisator (32) er tilstede på hver af de nedre sidedele (11a) af det nedre understel (11).
- 20
9. Kranvognen med roterende funktion (10) i henhold til krav 7 og den er kendetegnet ved at omfatte mindst et bagvedliggende angulært støtteben (34) forbundet med nævnte nedre understel (11), og som kan forlænges til jorden i en bestemt vinkel.
- 25
10. Kranvognen med roterende funktion (10) i henhold til krav 9 og den er kendetegnet ved, at mindst et af nævnte bagvedliggende angulære støtteben (34) er påsat hver sidedel af det nedre understel (11a) på det nedre understel (11).
- 30
11. Kranvognen med roterende funktion (10) i henhold til krav 1 og den er kendetegnet ved at omfatte
- 35
- mindst en trækarmsmekanisme (21), som sørger for forbindelse til køretøjer (90) til det nedre understel (11), og bugserer dem,
  - 40 - mindst en løftearm (20), som omfatter en løftearmscylinder (22), som sørger for bevægelser op og ned af trækarmsmekanismen (21),
  - 45 - og løftearmstrækspil (23).
12. Kranvognen med roterende funktion (10) i henhold til krav 1 og den er kendetegnet ved at omfatte en nedre afstandsjusteringsrulle (54) i forbindelse med de nedre slæbetov (49).
- 50
13. Kranvognen med roterende funktion (10) i henhold til krav 1 og den er kendetegnet ved at omfatte en retningsrulle (55), som

befinder sig i nævnte styrespindels (52) område.

# DRAWINGS

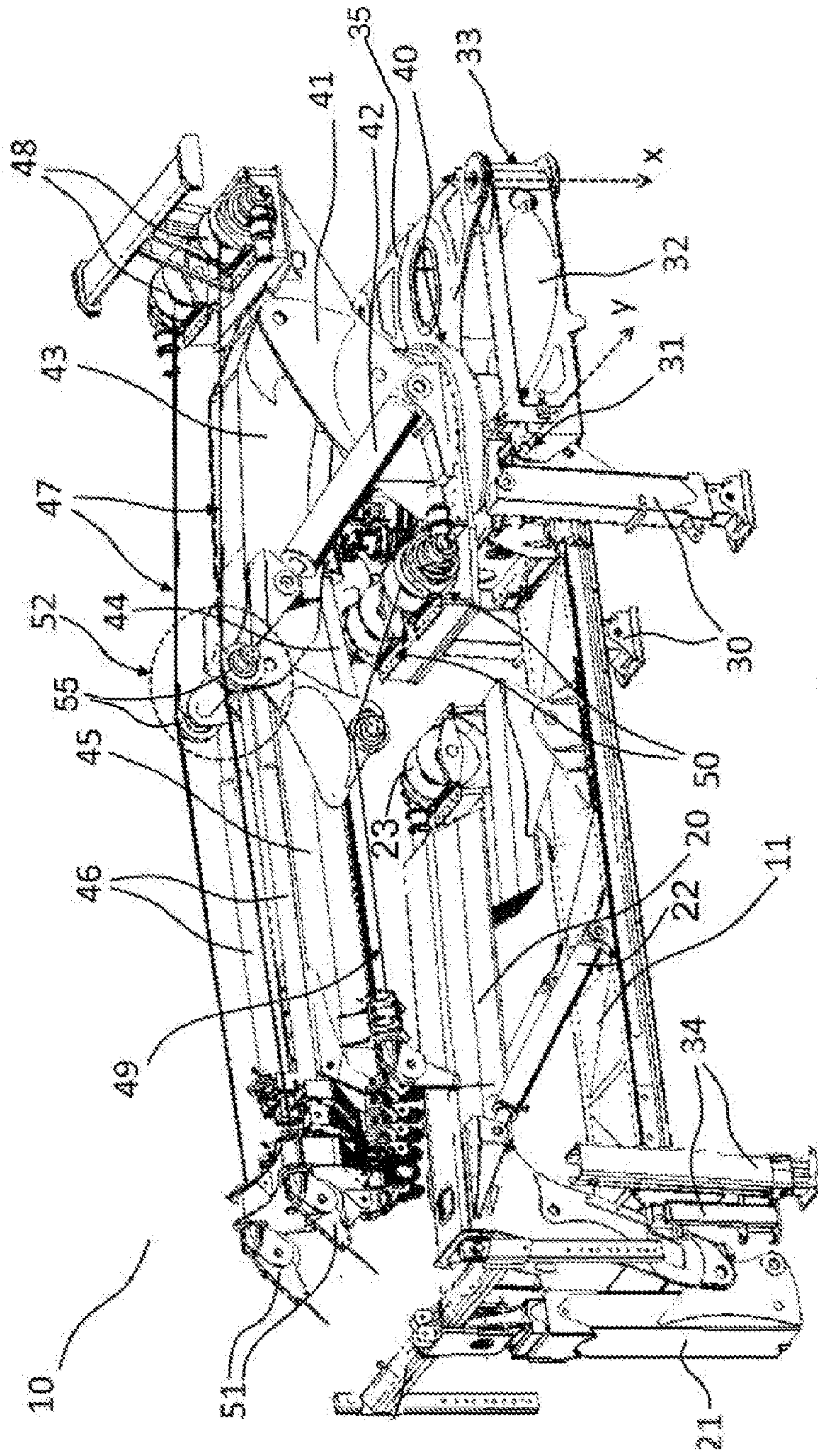

FIGURE - 1

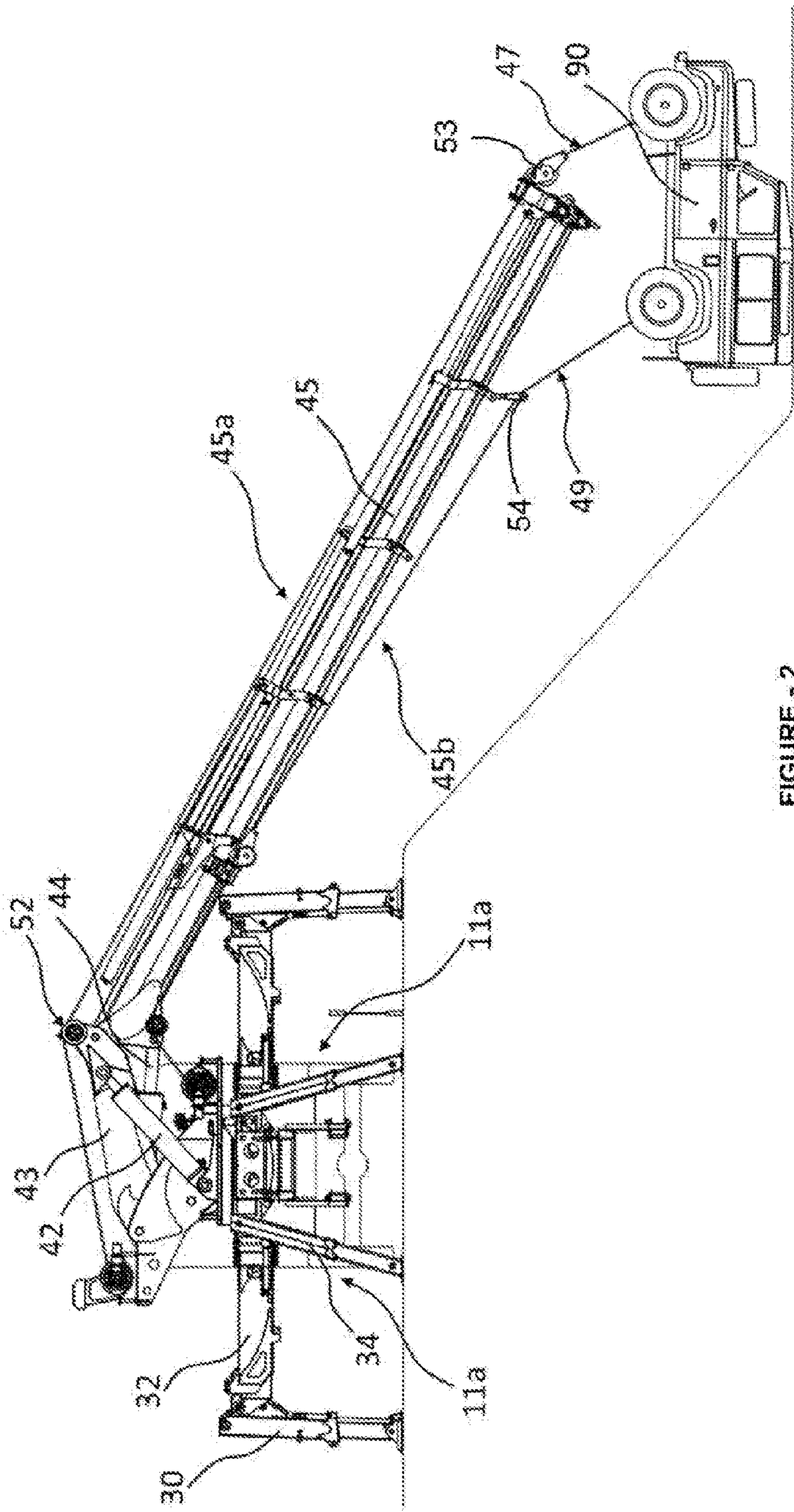

FIGURE - 2

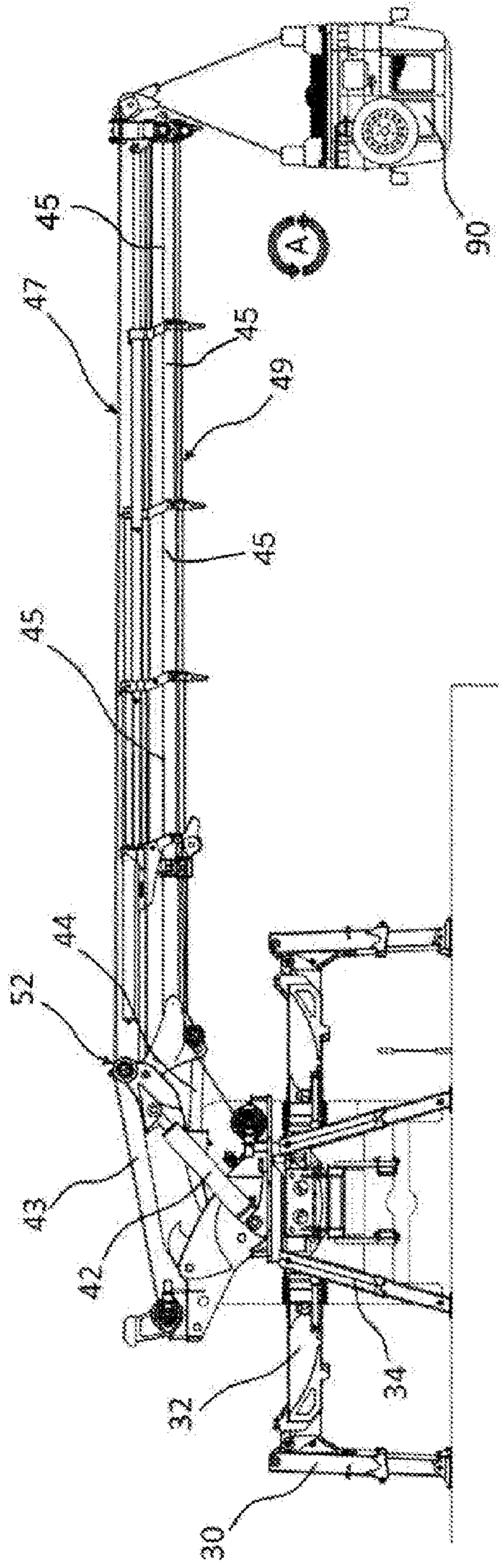

FIGURE - 3

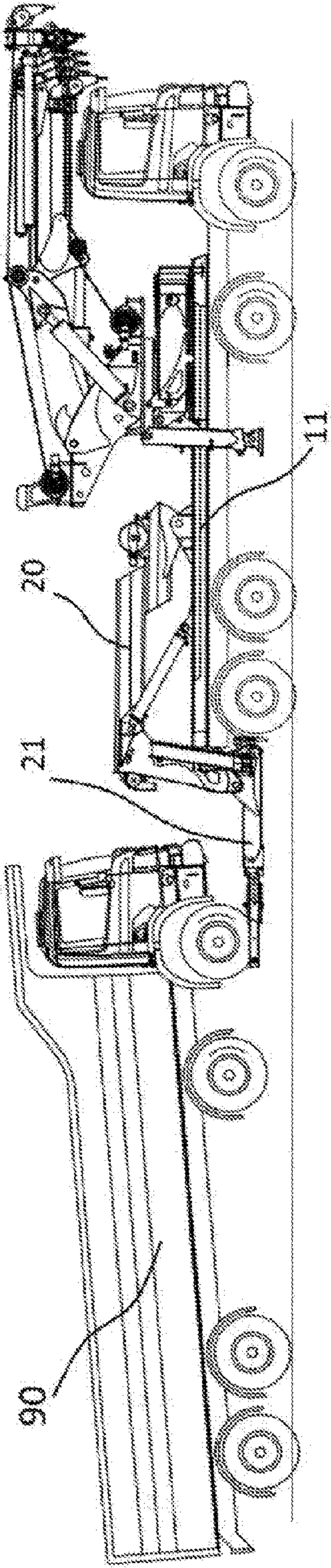

FIGURE - 4

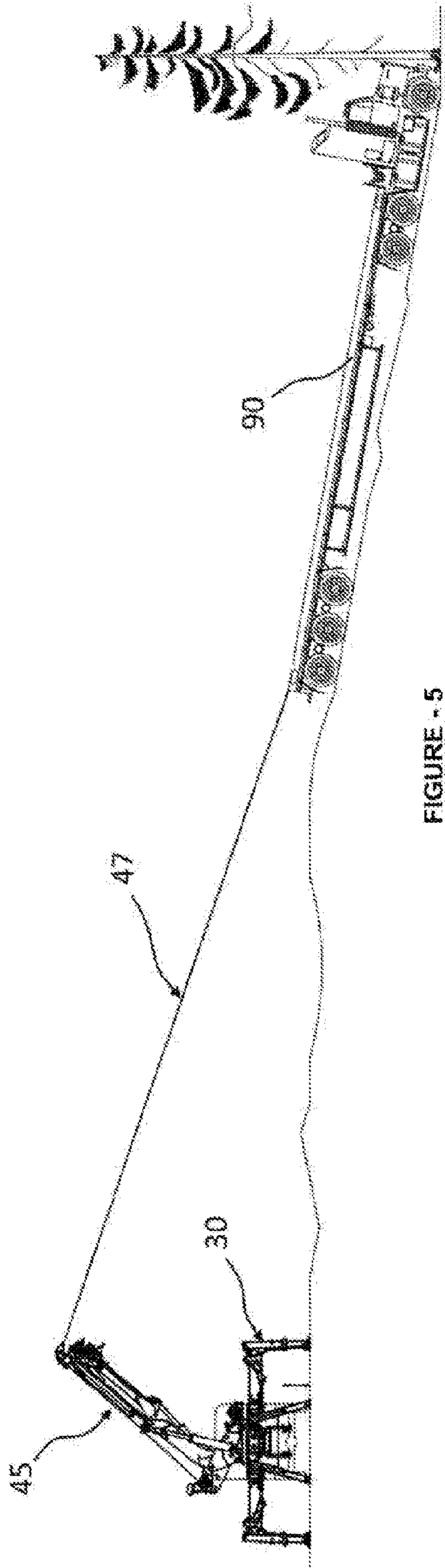

FIGURE - 5