

(19) World Intellectual Property Organization
International Bureau



(43) International Publication Date
12 June 2003 (12.06.2003)

PCT

(10) International Publication Number
WO 03/048829 A2

(51) International Patent Classification⁷: G02B 6/44

(21) International Application Number: PCT/GB02/05325

(22) International Filing Date:
27 November 2002 (27.11.2002)

(25) Filing Language: English

(26) Publication Language: English

(30) Priority Data:
0128622.8 29 November 2001 (29.11.2001) GB

(71) Applicant (for all designated States except US): GLOBAL MARINE SYSTEMS LIMITED [GB/GB]; East Saxon House, 27 Duke Street, Chelmsford, Essex CM1 1HT (GB).

(72) Inventors; and

(75) Inventors/Applicants (for US only): HART, Philip, Richard [GB/GB]; 7 Luther Drive, Tiptree, Essex CO5 0SQ (GB). DICKER, Keith, Alan [GB/GB]; Hunts Cottage, Shalford, Essex CM7 5HL (GB).

(74) Agent: GILL JENNINGS & EVERY; Broadgate House, 7 Eldon Street, London EC2M 7LH (GB).

(81) Designated States (national): AE, AG, AL, AM, AT, AU, AZ, BA, BB, BG, BR, BY, BZ, CA, CH, CN, CO, CR, CU, CZ, DE, DK, DM, DZ, EC, EE, ES, FI, GB, GD, GE, GH, GM, HR, HU, ID, IL, IN, IS, JP, KE, KG, KP, KR, KZ, LC, LK, LR, LS, LT, LU, LV, MA, MD, MG, MK, MN, MW, MX, MZ, NO, NZ, OM, PH, PL, PT, RO, RU, SC, SD, SE, SG, SI, SK, SL, TJ, TM, TN, TR, TT, TZ, UA, UG, US, UZ, VC, VN, YU, ZA, ZM, ZW.

(84) Designated States (regional): ARIPO patent (GH, GM, KE, LS, MW, MZ, SD, SL, SZ, TZ, UG, ZM, ZW), Eurasian patent (AM, AZ, BY, KG, KZ, MD, RU, TJ, TM), European patent (AT, BE, BG, CH, CY, CZ, DE, DK, EE, ES, FI, FR, GB, GR, IE, IT, LU, MC, NL, PT, SE, SK, TR), OAPI patent (BF, BJ, CF, CG, CI, CM, GA, GN, GQ, GW, ML, MR, NE, SN, TD, TG).

Published:
— without international search report and to be republished upon receipt of that report

For two-letter codes and other abbreviations, refer to the "Guidance Notes on Codes and Abbreviations" appearing at the beginning of each regular issue of the PCT Gazette.

(54) Title: OPTICAL CABLE DEVICE

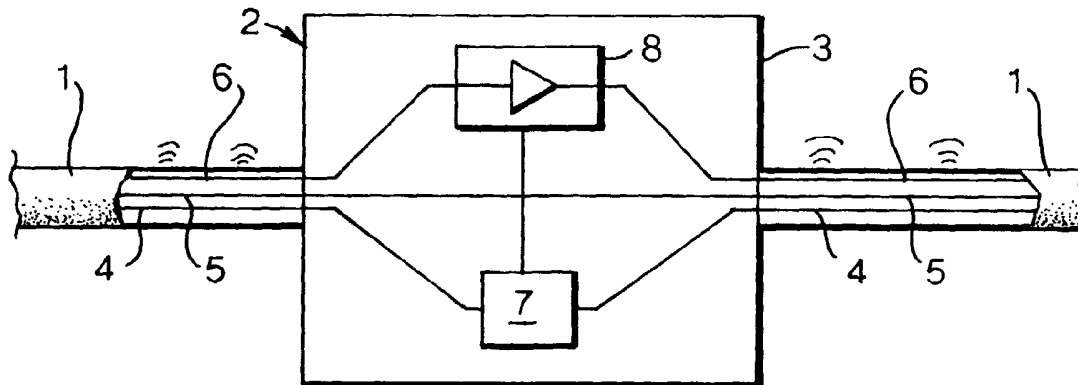

(57) Abstract: A device is provided that is adapted for use underwater for connection to an optical cable, the optical cable (1) having an electrically conducting member arranged along it. The device comprises a tone generator (8) for connecting to the electrically conducting member (6) of the optical cable, wherein the tone generator is arranged to transmit a toning signal along the electrically conducting member (6).



WO 03/048829 A2

OPTICAL CABLE DEVICE

The present invention relates to an optical cable device, for example forming part of an optical communications system for use in the location of submarine optical communications cables.

Whenever cables are buried underground and/or placed at depth underwater, it is desirable to be able to locate the cable at any position along its length. This might be for the purposes of repair or maintenance of the cable itself, to prevent the cable from becoming damaged by other operations nearby or indeed to demonstrate that the cable was correctly placed according to requirements.

There are a number of known methods of locating such cables and these include locally inducing a current within the cable and the use of magnetic methods. However, each of these methods is somewhat limited in that they are generally unsuitable for locating cables buried to a depth of greater than about 1.5 metres.

An alternative method which has been used successfully is that of "toning". This method works by effectively making the cable a transmitter such that very long wave radio signals are transmitted by the cable at a particular frequency and these are then detected using a receiver nearby. The use of this toning method relies upon the presence of some form of electrical conductor running along a cable to allow it to act as a transmitter. However, this is not a serious limitation as such a conductor is usually present.

One major problem with toning in optical cables is that the toning signal is severely attenuated by the presence of optical repeaters along the cable. These repeaters effectively block the toning signal and therefore in practice toning in such cables can only be used within about 100km of the cable end. Of course for submarine cables which provide communications links between countries, this distance of 100 or so kilometres is

inadequate. In particular, for transoceanic cables the vast majority of the cable is therefore undetectable using toning.

In accordance with a first aspect of the present invention we provide a device adapted for use underwater and for connection to an optical cable, the optical cable having an electrically conducting member arranged along it, the device comprising:-

a tone generator for connecting to the electrically conducting member of the optical cable, wherein the tone generator is arranged to transmit a toning signal along the electrically conducting member.

The present invention addresses the problems of toning in optical cables such as those having repeaters, by providing a device to be connected in use underwater to the cable at a location which is remote from the cable end. Examples of such remote locations include the positions of optical repeaters, branches or joints in an underwater optical cable system. The device has a tone generator which is connected to the electrically conducting member of the optical cable and is arranged to transmit a suitable toning signal along this conducting member. Unlike in known systems, the present invention allows toning signals to be produced in parts of an optical cable which are separated from the cable end (located onshore for a submarine cable) by a number of repeaters or other components such as joints or branches.

The term "tone generator" here is intended to include either apparatus which generates or reproduces the toning signal locally or apparatus which enhances a toning signal received from a remote source. The tone generator may therefore generate the toning signal itself and/or amplify a toning signal received from a remote source. In addition, when acting as an amplifier, the toning generator may receive a toning signal and actually regenerate the toning signal before transmission. Suitable signal

processing can be used to maximise the range of the toning signal along the optical cable.

The device may be adapted to be connected to the optical cable at the location of a repeater, joint or branch unit. It may therefore be spliced as a separate device into the cable in "parallel" with these other components. The device may also be mounted to the housing of such components. By providing the device at the location of such components their attenuating effect upon the toning signal can be largely avoided as the device ensures that the tone is transmitted downstream of the component concerned. Alternatively to the provision of a separate device, the invention also contemplates the use of repeaters, joints or branching units containing such a device, for example forming an integral unit.

The electrically conducting member may form one or more of, the power supply member for the optical cable, a strength member for supporting the cable, or an armour member such as the cable armour, provided that these are electrically conducting. Typically the strength member or cable armour will be formed from a high strength material such as twisted steel strands. One or more of these strands may be used as the electrically conducting member.

The tone generator may be powered by a similar power supply as that which provides power to an optical repeater. Conventionally this is in the form of a DC cable running along the optical cable. However, the device may further comprise a self-contained power supply for powering the tone generator.

Preferably the operation of the tone generator will be controllable and therefore the device will preferably further comprise a remote control system for controlling the operation of the tone generator such that the transmission of toning signals by the tone generator along the electrically conducting member can be enabled and disabled. Typically this may be achieved using a switching device which is responsive to the remote control system,

for example using switching signals received from a remote source. The switching signal may be received along the optical cable or indeed may be received from a local source such as, in the case of submarine cables, a transmitter
5 attached to a surface vessel.

In either case, the ability to enable or disable the tone generator at will, for any particular device, provides the advantage that a toning signal can be placed on only part of the optical cable, for example between particular
10 repeaters.

The toning signal is typically a electrical signal having a frequency of between 1 and 50 Hertz as this frequency is particularly suitable for detection. Generally a sinusoidal waveform is used.

15 Preferably the device will form part of an optical communication system. Therefore, in accordance with a second aspect of the present invention an optical communication system comprises:

an optical cable for the transmission of optical
20 signals, the optical cable having an electrically conducting member arranged along it; and

at least one device according to any of the preceding claims and positioned along the cable, the tone generator of the or each device being connected to the electrically
25 conducting member of the optical cable.

As before, the device may be in the form of a component such as an optical repeater, branch unit or joint.

Although at least one device according to the
30 invention may be provided, typically there will be a large number of such devices (within components such as repeaters or otherwise) and these may be used in conjunction with conventional repeaters. Preferably each of the devices according to the first aspect of the invention are located
35 between a first and second section of the optical cable such that the toning generator, when acting as a tone amplifier or regenerator, receives the toning signal along

the first section of the optical cable and transmits the toning signal along the second section of the optical cable.

Although the system (and devices) could be used in any environment, it is particularly useful for hostile environments in which a large proportion of the cable may not be readily accessible. The optical device and optical cable are adapted for use in submarine environments and are water-sealed. In many such cases, the cable and device may be buried, for example within the seabed. A further example of such a system is that of an umbilical system. These are used typically in providing services between oil or gas platforms and remote well heads. Such umbilicals often contain optical and electrical cables, as well as hydraulic lines.

The invention can also be used in underwater systems for traversing smaller stretches of water such as rivers and lakes. It can also be used in a combined system traversing areas of land and water.

In accordance with a third aspect of the present invention we provide a method of locating an optical cable in an optical communication system according to the second aspect of the invention, the method comprising:-

operating the tone generator so as transmit the toning signal along the electrically conducting member;

detecting electromagnetic waves emitted from the electrically conducting member as a result of the toning signal transmission; and

locating the optical cable using the detected electromagnetic waves.

Thus in accordance with the third aspect of the invention the position of an optical cable can be detected at locations such as those remote from the cable end by the operation of the devices to transit the toning signal. The method is particularly advantageous in locating parts of such cables which are separated from the cable end by one

or more components such as repeaters which conventionally attenuate toning signals.

Preferably when the communication system includes a remote control system the method further comprising
5 operating the remote control system to emit control signals so as to selectively enable or disable the at least one device such that a toning signal is transmitted along part of the optical cable. In this case selective parts of the optical cable can be caused to emit the electromagnetic
10 waves, for example in the region of a known fault which may be extremely remote from the cable end such as in the middle of an ocean. Devices capable of originating the toning signal can be used for this purpose.

The control signals emitted by the remote control
15 system may be transmitted along the optical cable within the optical fibres, or within the electrically conducting member. In this case they are typically transmitted along the optical cable from one of the cable ends. Alternatively the control signals may be transmitted from
20 a source located in the vicinity of the device(s). For example, in the case of an undersea cable, the signals may be transmitted from a surface ship, a submarine or a remotely operated vehicle (ROV).

Some examples of devices according to the present
25 invention will now be described with reference to the accompanying drawings, in which:-

Figure 1 shows a schematic optical repeater according to a first example;

Figure 2 shows a cross-section of an armoured optical
30 cable;

Figure 3 shows the use of the repeater of the first example in locating a submarine cable;

Figure 4 is a second example of a repeater for generating the toning signal locally;

35 Figure 5 is a third example of a repeater having a bidirectional toning function;

Figure 6 is an example of a separate toning device fitted in parallel with a repeater of an umbilical system; and,

Figure 7 is an example in which a toning device is mounted to a branch unit.

Referring to Figure 1, a submarine cable 1 is shown connected to a device in the form of a repeater 2 having a water-sealed repeater housing 3. The cable 1 contains a number of optical fibres generally indicated at 4, each fibre forming an optical communication member for transmitting optical signals. A power supply cable 5 is also shown, this providing the power supply to the systems of the repeater 2. An electrically conducting member 6 is also shown forming part of the cable 1. The electrically conducting member may take a number of forms as will be described and is responsible for transmitting a toning signal along the optical cable 1.

Inside the repeater 2, the optical fibres 4 are connected to an optical enhancement system 7, this system generally representing any of the known systems for processing optical signals, such as pulse shaping and pulse regenerating systems. This enhancement system 7 is powered by the power supply cable 5 which in the present case is a direct current (DC) power supply cable for powering the typically solid state devices used in the optical enhancement system 7.

Within the repeater 2, the electrically conducting member 6 is connected to a tone generator in the form of a tone signal amplifier 8 which amplifies and filters the toning signal provided on the electrically conducting member 6. The tone signal amplifier 8 is powered by the power supply cable 5 in a similar manner to the optical enhancement system 7. Beyond the optical enhancement system 7 and the tone signal amplifier 8, the optical fibres 4 and the electrically conducting member 6 exit the repeater and continue along the submarine cable 1.

A cross-section through a typical submarine cable 1 is shown in Figure 2. The cable has a central core 20 as a strengthening member, for example constructed from steel. Surrounding this, a number of fibres 4 are shown contained within a supportive matrix material 21. The matrix material 21 is protected by coaxial steel armouring strands 22 wrapped around the outer surface of the matrix material 21. The power supply to the cable 1 is provided by a conducting copper sheath which acts as the power supply cable 5. This is surrounded by a layer of coaxial insulating material 23.

The main armour 24 of the cable is provided by a number of thick densely packed steel cables which are tightly wrapped around the periphery of the insulating layer 23. A final protective coating 25 forms the outer surface of the submarine cable 1. Each of these elements of the optical cable 1 are elongate and run along the length of the cable such that Figure 2 represents a typical cross-section taken at any point.

It will be appreciated that as the core strengthening member 20, the steel armouring strands 22, the power supply cable 5 and the main armour 24 are each formed from electrically conducting materials. Of course, the main function of the power supply cable 5 is to provide electrical power to the repeater 2 and therefore it has good conductivity properties.

Each of these four elements, due to their electrically conducting properties, may be used to carry a toning signal along the cable. However, apart from the power supply cable 5, the armour and strength elements may not always be present, depending upon the application.

The advantage of using the main armour 24 is that it is not enclosed coaxially by any other conducting components. This reduces the attenuation of the signals transmitted away from the cable which are used to locate the cable.

However, as there are a large number of the steel wires forming the main armour 24 or the steel armouring fibres 22 and because such armour may be prone to damage, it may be more convenient to use the core strength member 20 for this task. As long as the toning signal does not interfere with the power supply of the repeater systems, the conducting properties of the power supply cable 5 are beneficial for using this cable as the electrically conducting member 6. Of course a further dedicated electrically conducting member 6 could be used.

Figure 3 schematically shows the use of the cable and repeaters as described above in a toning system for locating the cable 1.

In Figure 3 the optical cable 1 is buried beneath an expanse of water such as an ocean indicated at 30. A number of repeaters 2A, 2B, 2C are positioned along the cable at approximately equal intervals of about 40km. One end of the cable 1 is shown connected to an onshore cable-end tone generator 31.

The cable-end tone generator 31 transmits the toning signal on the electrically conducting member 6. Typically, a low frequency tone is used between 1 and 50 Hertz. Once the toning signal enters the repeater 2A, it is amplified by the tone signal amplifier 8. This amplification may also involve filtering or cleaning of the signal before it is sent on along the cable beyond the repeater 2A and towards the next repeater 2B. Because each of the tone signal amplifiers 8 within the various repeaters 2A, 2B, 2C is arranged to amplify and clean the toning signal, a high quality tone signal can be placed upon the cable at hundreds and even thousands of kilometres from the end of the cable at which the signal generator 31 is located.

Assuming there is a fault in the cable at the position marked 32 in Figure 3 a few hundred kilometre offshore, it would ordinarily be very difficult to locate this cable, particularly as it may be in very deep water. However, in

this case a surface vessel 33, positioned above the approximate location of the cable is able to detect the cable 1 by towing a receiving device 34 across the seabed. The receiving device 34 may be attached to a towed sled or
5 intelligent grapnel. Alternatively it could be mounted to a remote operated vehicle (ROV).

Because the electrically conducting member 6 carries the toning signal, this can be remotely detected at points close to the cable with the receiving device 34 by
10 monitoring for the receipt of the characteristic signal emitted by the cable 1 when carrying the toning signal.

Once the cable has been located then its position can be charted or conventional recovery operations can be performed in order to repair or replace components of the
15 cable.

An additional advantageous feature of the tone signal amplifier 8 according to this example is that each amplifier 8 can be fitted with a simple switch to prevent connection between the parts of the electrically conducting
20 member 6 on either side of the amplifier 8. The switch can be conveniently operated via the control system that controls the optical enhancement system 7 such as using the optical fibre or the DC power supply. Control signals identifying the repeater and whether to make connection
25 between either side of the electrically conducting member 6 may be provided along the optical fibres 4 of the optical cable or in the DC power supply of the power supply cable 5.

Returning to Figure 3, with a switchable amplifier, it
30 is also possible therefore to locate specific repeaters such as repeater 2C in that once the cable has been located upon the costal side of the repeater 2C, using the receiver 34, the surface vessel can be moved along the cable until the signal ends, thereby indicating the position of the
35 repeater 2C.

Turning now to Figure 4, a second example of a repeater 2 is provided. In this case, the tone signal

amplifier 8 has been replaced by a tone generator in the form of a tone signal generator 40. This operates in a similar manner to the tone signal amplifier in that it transmits a tone of the required form along the electrically conducting member 6 beyond the repeater 2. However, it does not receive any incoming tone from the shore and therefore the cable-end tone generator 31 shown in Figure 3 is not required. Although the tone signal generator 4 within the repeater 2 may be powered by the power supply cable 5, a separate power supply 41 is shown in this case which may take the form of a long life battery as it is not anticipated that the toning system would be required to be used often. A similar battery 41 could also be used as an alternative means of supplying power to the tone signal amplifier 8 of the previous example.

In this example, it is particularly advantageous that the operation of tone signal generator 40 of the repeater 2 should be controllable in a similar manner to the optical enhancement system 7. In this way, a toning signal may be generated from any repeater at will and the next repeater along the cable could be arranged such that the signal does not pass through the repeater and therefore only the section of cable between specific repeaters would transmit a signal for detection.

The repeater of this second example may also be modified so as to achieve a "bidirectional function" according to a third example.

In this case the tone signal generator 40' is connected to the electrically conducting member 6 extending along the cable 1 in both directions away from the repeater, that is, along a first and second cable length upon either side of the repeater. This is illustrated in Figure 5.

Referring to Figure 6, a separate toning device 50 is provided, this being spliced into the DC power supply cable 5 of an umbilical system. In a similar manner to a conventional optical communications cable, the umbilical

system has a number of optical fibres 4, and corresponding repeaters 2. The toning device 50 is shown connected in "parallel" across the repeater 2 so as to ensure transmission of a tone in either direction from the repeater location. In this case the device 50 is adapted to either emit a toning signal or retransmit a received toning signal. It also has a bi-directional function. The DC power supply cable 5 is used to transmit the toning signal.

10 In Figure 7 a branching unit 60 is shown, within which three optical cables meet and are joined. The optical fibres 51,52,53 from the cables are spliced together in the branching unit 60. Each of these also has a DC power supply cable 54,55,56 associated with it. A toning device 15 50' is shown which is capable of placing a toning signal originating at the device upon each of the three DC power cables 54,55,56. In this case the toning device 50' is mounted to the housing of the branching unit 60.

It will also be appreciated that the toning devices of any of the above examples could be used in combination in the same cable or indeed that any device may be provided with both amplifying and tone generating capabilities. In all cases separate toning devices, devices mounted upon cable component housings, or devices within or integral with these components (repeaters, branching units or joints) can be used depending upon the application.

The tone signal generated using the present system is useful for locating both buried and non-buried underwater cables. In general, cables at a depth of greater than 2000 metres of water are not buried. At shallower depths, cables which are buried and yet are still hundreds of kilometres offshore, these cables are extremely difficult to find using conventional methods. The present invention provides the ability to locate such cables using toning and this is extremely effective as the tone may be detected to up to a depth of 20 metres beneath the seabed. As conventional cables are generally buried to depths of up to

around 3 metres, this depth is well within the detectable range.

CLAIMS

1. A device adapted for use underwater and for connection to an optical cable, the optical cable having an electrically conducting member arranged along it, the device comprising:-
- 5
- a tone generator for connecting to the electrically conducting member of the optical cable, wherein the tone generator is arranged to transmit a toning signal along the electrically conducting member.
- 10
2. A device according to claim 1, wherein the device is adapted to be connected to the optical cable at a location along the cable which is remote from the cable end.
3. A device according to claim 1 or claim 2, wherein the tone generator is a tone amplifier adapted to receive a remotely generated toning signal along the electrically conducting member, to amplify the received toning signal and to transmit the amplified toning signal along the electrically conducting member.
- 15
4. A device according to claim 3, wherein the tone amplifier regenerates the received toning signal.
- 20
5. A device according to claim 1 or claim 2, wherein the toning signal originates at the tone generator.
6. A device according to claim 5, wherein the device is arranged to be connected to a first length and a second length of the optical cable and wherein the tone generator is connected to the electrically conducting member so as to generate the toning signal in each of the first and second lengths of the optical cable.
- 25
7. A device according to any of the preceding claims, wherein the device further comprises a self-contained power supply for powering the tone generator.
- 30
8. A device according to any of the preceding claims, further comprising a remote control system for controlling the operation of the tone generator such that the transmission of toning signals by the tone generator along
- 35

the electrically conducting member can be enabled and disabled.

9. A device according to claim 8, further comprising a switch device for enabling and disabling the operation of the tone generator in response to the remote control system.

10. A device according to any of the preceding claims adapted for use in a submarine environment.

11. A device according to any of the preceding claims, wherein the toning signal is an electrical signal.

12. A device according to claim 11, wherein the toning signal has a frequency of between 1 and 50Hz.

13. A device according to any of the preceding claims, wherein the device is adapted to be connected to the optical cable at the location of a cable repeater, joint or branch unit.

14. A device according to claim 13, wherein the device is adapted to be mounted to a housing of the cable repeater, joint or branch unit.

15. A device according to any of claims 1 to 12, wherein the device is an optical cable repeater.

16. A device according to any of claims 1 to 12, wherein the device is an optical cable joint or optical cable branching unit.

17. An optical communication system comprising:

an optical cable for the transmission of optical signals, the optical cable having an electrically conducting member arranged along it; and

at least one device according to any of the preceding claims and positioned along the cable, the tone generator of the or each device being connected to the electrically conducting member of the optical cable.

18. An optical communication system according to claim 17 when dependent upon claim 3, wherein the at least one device is located between a first and a second section of the optical cable and wherein the tone generator receives the toning signal along the first section of the optical

cable and transmits the toning signal along the second section of optical cable.

19. An optical communication system according to claim 17 or claim 18, wherein the electrically conducting member is a power supply member for the optical cable.

20. An optical communication system according to any of claims 17 to 19, wherein the electrically conducting member is a strength member for the optical cable.

21. An optical communication system according to any of claims 17 to 20, wherein the electrically conducting member is an armour member for the optical cable.

22. An optical communication system according to any of claims 17 to 21, wherein the optical communication system is located in a submarine or underwater environment.

23. An optical communicating system according to any of claims 17 to 22, wherein the system is an umbilical system.

24. A method of locating an optical cable in an optical communication system according to any of claims 17 to 23; the method comprising:-

operating the tone generator so as to transmit the toning signal along the electrically conducting member;

detecting electromagnetic waves emitted from the electrically conducting member as a result of the toning signal transmission; and

locating the optical cable using the detected electromagnetic waves.

25. A method according to claim 24 and when dependent upon claim 8, further comprising operating the remote control system to emit control signals so as to selectively enable or disable the at least one device such that a toning signal is transmitted along part of the optical cable.

26. A method according to claim 25, wherein the control signals are transmitted along the optical cable from a cable end.

27. A method according to claim 25, wherein the control signals are transmitted from a source located in the vicinity of the device(s).

28. A method according to claim 27, wherein the signals are transmitted from a surface vessel, submarine or remotely operated vehicle.

Fig.1.

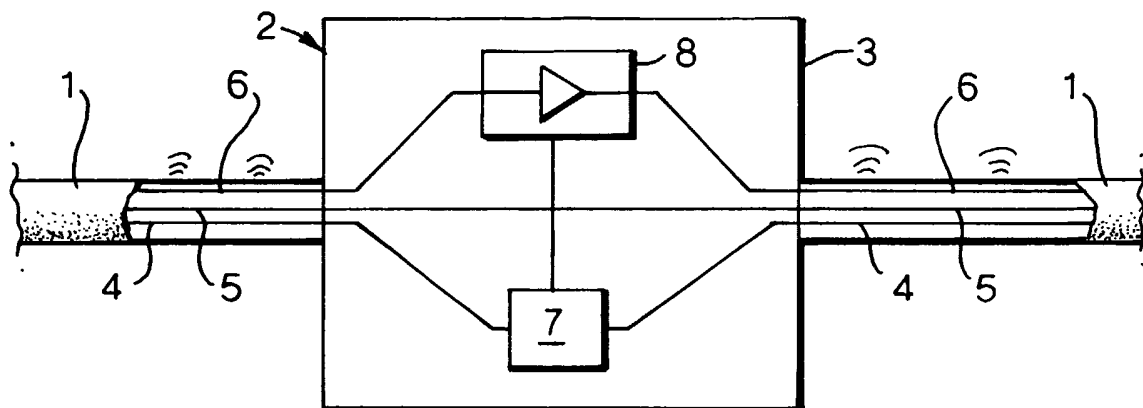
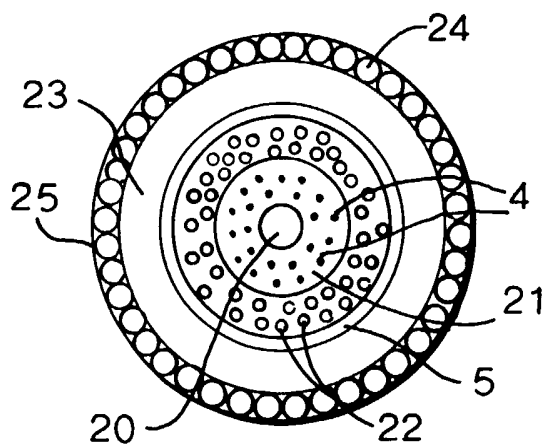

Fig.2.



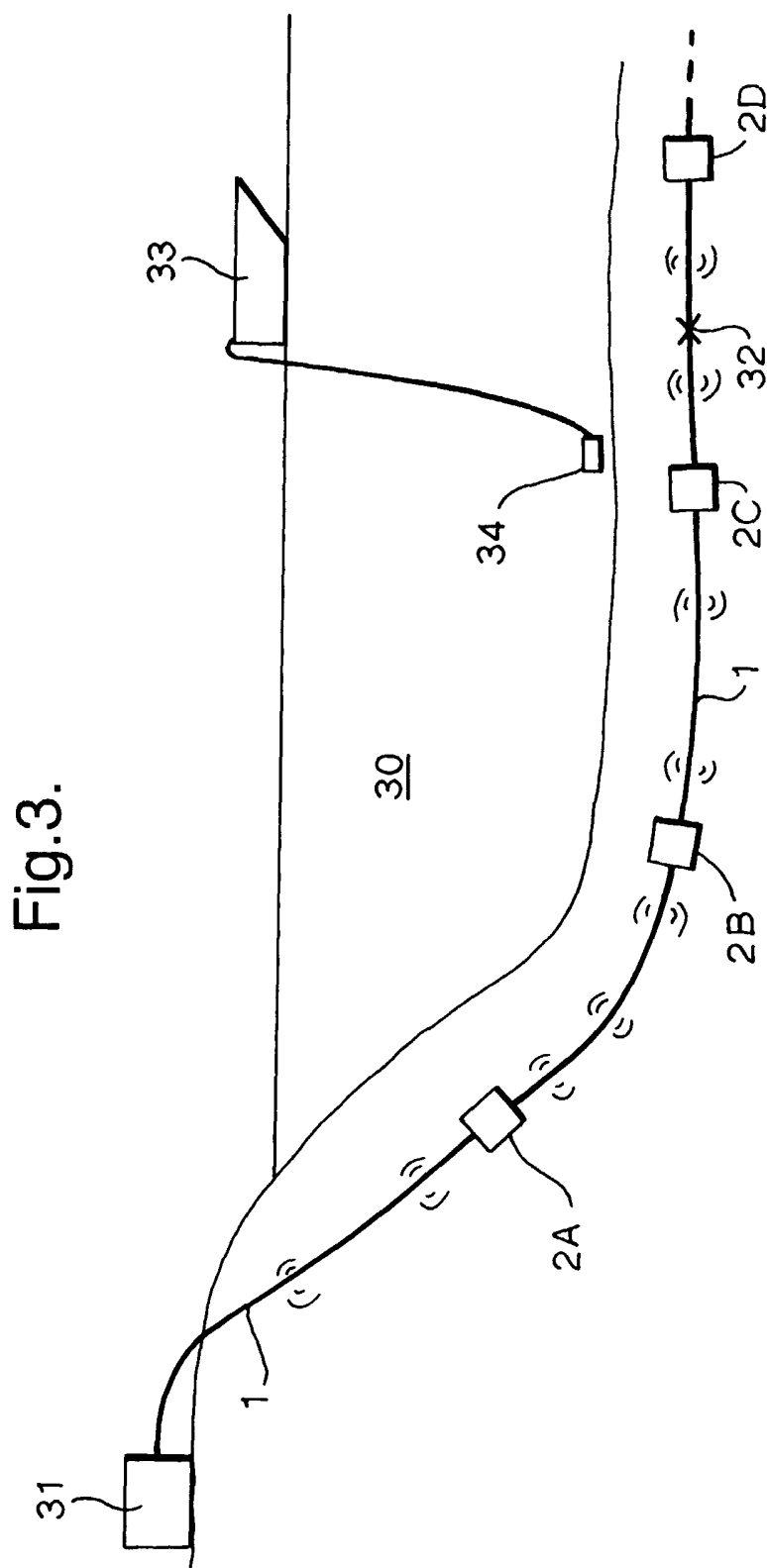

Fig.3.

Fig.4.

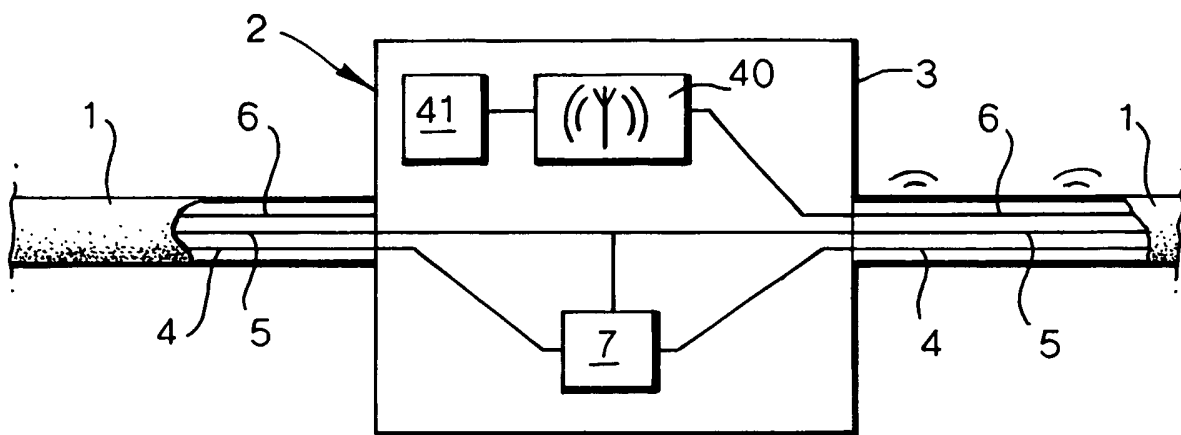

Fig.5.

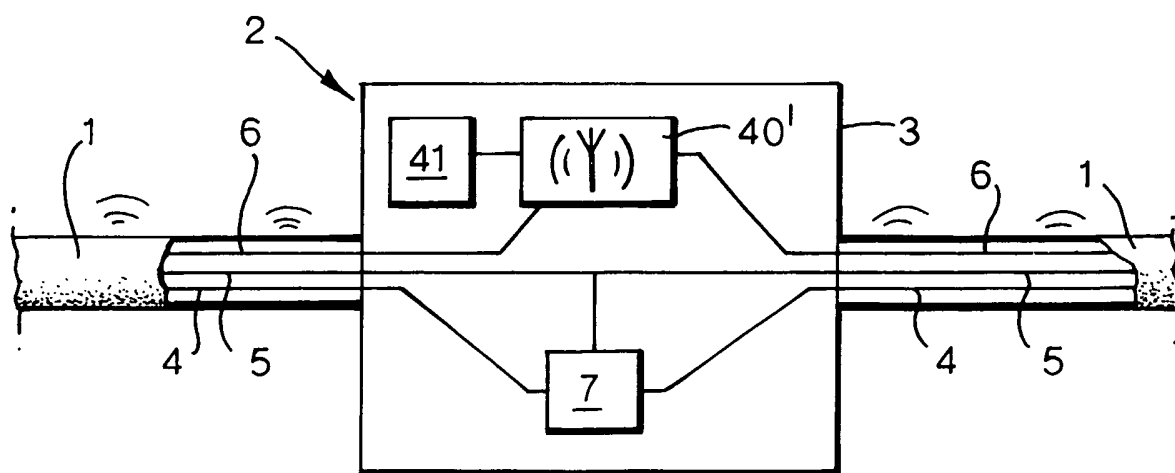

Fig.6.

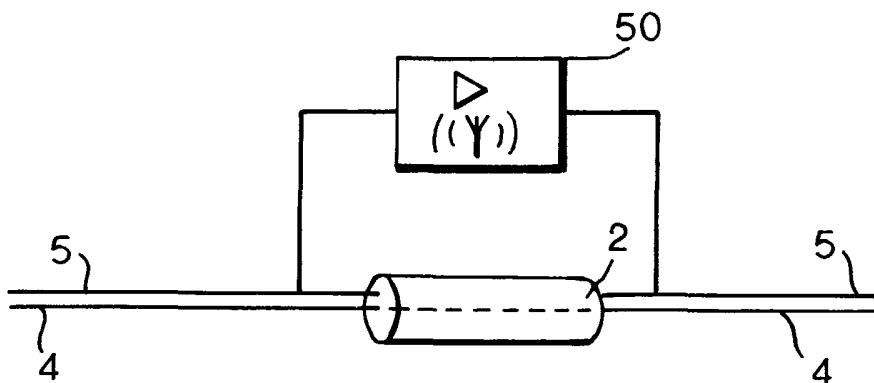

Fig.7.

