

No. 823,154.

PATENTED JUNE 12, 1906.

H. L. BLUE.  
AUTOMATIC CAR COUPLING.  
APPLICATION FILED NOV. 18, 1905.

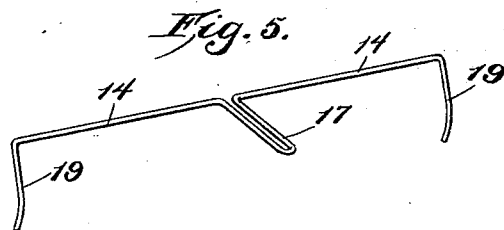
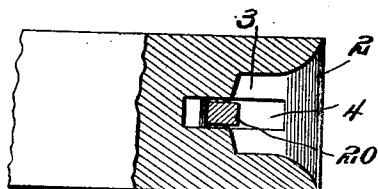
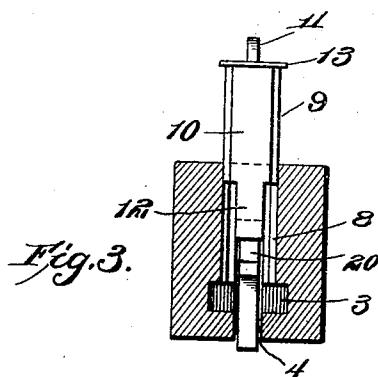
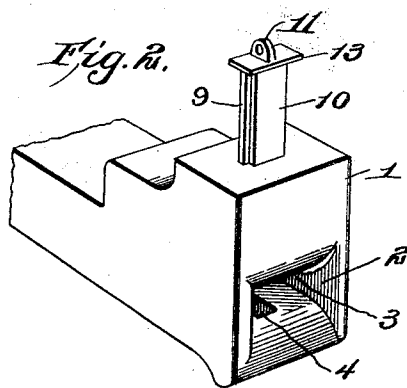
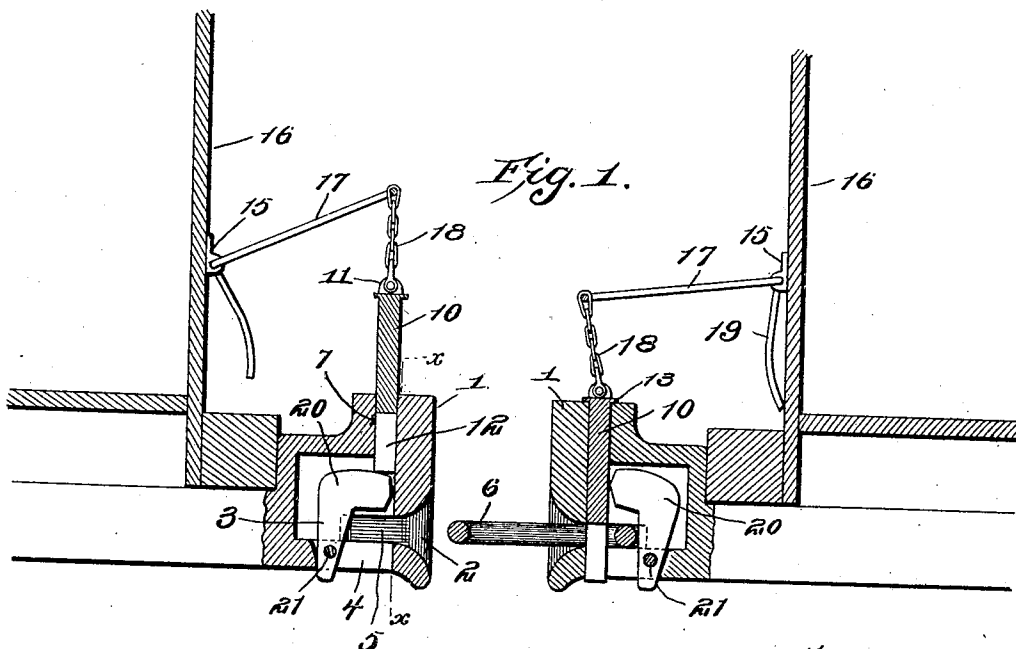

Fig. 4.

Fig. 5.

Witnesses

Louis R. Hennrichs  
Herbert D. Lawson.

Inventor  
H. L. Blue

By  
W. J. Fitzgerald & Co.,  
Attorneys

# UNITED STATES PATENT OFFICE.

HENRY L. BLUE, OF ST. ELMO, COLORADO.

## AUTOMATIC CAR-COUPLING.

No. 823,154.

Specification of Letters Patent.

Patented June 12, 1906.

Application filed November 18, 1905. Serial No. 288,014.

*To all whom it may concern:*

Be it known that I, HENRY L. BLUE, a citizen of the United States, residing at St. Elmo, in the county of Chaffee and State of Colorado, have invented certain new and useful Improvements in Automatic Car-Couplers; and I do hereby declare the following to be a full, clear, and exact description of the invention, such as will enable others skilled in the art to which it appertains to make and use the same.

My invention relates to car-couplers; and its object is to provide a device of this character having a locking-pin adapted to automatically engage a coupling-link when said link is inserted into the draw-head.

Another object is to provide means whereby the locking-pin will be automatically engaged and supported when raised out of engagement with the link.

With the above and other objects in view the invention consists of a draw-head having a locking-pin slidably mounted therein and adapted to be supported in raised position by a tumbler of novel form which is so mounted within the draw-head as to be moved from position under the locking-pin when the coupling-link is forced into contact therewith.

The invention also consists of the further novel features of construction and combination of parts hereinafter more clearly described, and pointed out in the claims.

In the accompanying drawings I have shown the preferred form of my invention.

In said drawings, Figure 1 is a vertical longitudinal section through two car-couplers constructed in accordance with my invention and showing the position of the parts just prior to the coupling operation. Fig. 2 is a perspective view showing the front face of the draw-head and the locking-pin raised. Fig. 3 is a section on line *x x*, Fig. 1. Fig. 4 is a horizontal section through the draw-head and pin, and Fig. 5 is a detail view of the pin-actuating rod.

Referring to the figures by numerals of reference, 1 is a draw-head having a mouth 2, which opens into a compartment 3, formed within the draw-head, and a slot 4 is located within the bottom of the draw-head and opens into said compartment 3. The side walls of the compartment are enlarged laterally close to the bottom thereof, as shown at 5, so as to accommodate the coupling-link 6.

A passage 7 is formed in the top of the draw-head and opens into compartment 3, and the side walls of this passage are grooved, as shown at 8, to receive beads 9, extending longitudinally along the sides of the coupling-pin 10. This pin has an ear 11 at its upper end and a tongue 12 at its lower end, said tongue being equal in width to the width of the slot 4 and adapted to rest in said slot when the pin is in lowered position. A cap 13 is formed on the pin at its upper end and serves to limit its downward movement. A rotatable rod 14 is mounted in brackets 15 on the end of the car 16 and has an arm 17 near the center thereof, from which depends a chain 18, which is secured to ear 11. Handles 19 are located at the ends of the rod 14, so that the same can be manipulated from either side of the car. Pivoted in the slot 4 is one end of a tumbler 20, which is substantially L-shaped and the head of which normally rests by gravity below the pin 10 and in the compartment 3. This tumbler can be inserted into the compartment 3 or removed therefrom through the slot 4, provided the pivot-pin 21 thereof is first removed.

When it is desired to secure a link in the draw-head, the same is forced into the draw-head and will contact with the tumbler 20 at a point above its pivot. Said tumbler will therefore be pressed backward from under the pin 10, and said pin will fall by gravity, so that its tongue 12 will enter the link and the forward end of slot 4. To release the link, rod 14 is rotated so as to draw the pin upward, and as soon as this pin passes above the tumbler said tumbler will by gravity reassume a position under the pin and will support it until again removed from under it.

In coupling two cars together link 6 is first secured in one of the couplers, and the locking-pin of the other coupler is then raised. The parts of the two couplers will therefore assume the positions shown in Fig. 1, and by bringing the two draw-heads together the same will be coupled in the manner hereinbefore described.

By constructing the pin in the manner shown considerable weight may be added to it to facilitate its operation, and at the same time the engagement of the pin with the link will not be interfered with. The particular form of tumbler employed by me does not require the use of springs or other like devices for facilitating the operation thereof. More-

over, the coupler is formed of but three parts—  
 the draw-head, tumbler, and locking-pin—  
 and therefore there are no parts to get out of  
 order. The lower end of the coupling-pin  
 5 is braced by the front wall of the slot 4 when  
 the link is engaged by said pin and cannot,  
 therefore, become twisted or bent. The  
 tumbler can be readily removed in case of in-  
 jury thereto by simply withdrawing its pivot-  
 10 pin 21 and allowing said tumbler to slip out  
 through the slot 4.

What I claim is—

1. In a coupler, the combination with a  
 draw-head having a compartment therein  
 15 provided with a slot in the bottom thereof  
 and a mouth in the front of said compart-  
 ment; of a locking-pin slidably mounted in  
 the top of the draw-head and projecting into  
 the compartment, said pin having an inte-  
 20 gral tongue at its lower end beads on oppo-  
 site sides of said pin adapted to engage  
 grooves in the draw-head, and an angular  
 tumbler pivoted at one end within the slot  
 and projecting across the mouth and nor-

mally resting by gravity below the raised 25  
 locking-pin.

2. The combination with a draw-head hav-  
 ing a compartment therein provided with a  
 mouth in its front wall and a slot in its bot-  
 tom; of a locking-pin slidably mounted with- 30  
 in the top of the draw-head and having an  
 integral tongue upon the bottom thereof lon-  
 gitudinal beads on opposite sides of said pin  
 adapted to enter grooves in the draw-head,  
 means for raising the pin, and an angular 35  
 tumbler within the compartment and adapted  
 to be inserted through the slot, said tumbler  
 being pivoted at one end within one end of  
 the slot and normally resting, by gravity,  
 under the locking-pin. 40

In testimony whereof I have signed my  
 name to this specification in the presence of  
 two subscribing witnesses.

HENRY L. BLUE.

Witnesses:

HARDEN Y. CARSON,  
 C. L. CRAIG.