



- (51) International Patent Classification:  
*E01F 15/08* (2006.01)
- (21) International Application Number:  
PCT/NL2021/050016
- (22) International Filing Date:  
13 January 2021 (13.01.2021)
- (25) Filing Language: English
- (26) Publication Language: English
- (30) Priority Data:  
2024721 21 January 2020 (21.01.2020) NL
- (71) Applicant: **LAURA METAAL HOLDING B.V.**  
[NL/NL]; Rimbürgerweg 40, 6471 XX Eygelshoven (NL).
- (72) Inventors: **RAMAEKERS, Nicky Joseph Gerardus**; c/o Rimbürgerweg 40, 6471 XX Eygelshoven (NL). **DEBETS, Tim**; c/o Rimbürgerweg 40, 6471 XX Eygelshoven (NL).
- (74) Agent: **PATENTWERK B.V.**; P.O. Box 1514, 5200 BN 's-Hertogenbosch (NL).
- (81) Designated States (unless otherwise indicated, for every kind of national protection available): AE, AG, AL, AM, AO, AT, AU, AZ, BA, BB, BG, BH, BN, BR, BW, BY, BZ, CA, CH, CL, CN, CO, CR, CU, CZ, DE, DJ, DK, DM, DO, DZ, EC, EE, EG, ES, FI, GB, GD, GE, GH, GM, GT, HN, HR, HU, ID, IL, IN, IR, IS, IT, JO, JP, KE, KG, KH, KN, KP, KR, KW, KZ, LA, LC, LK, LR, LS, LU, LY, MA, MD, ME, MG, MK, MN, MW, MX, MY, MZ, NA, NG, NI, NO, NZ, OM, PA, PE, PG, PH, PL, PT, QA, RO, RS, RU, RW, SA, SC, SD, SE, SG, SK, SL, ST, SV, SY, TH, TJ, TM, TN, TR, TT, TZ, UA, UG, US, UZ, VC, VN, WS, ZA, ZM, ZW.
- (84) Designated States (unless otherwise indicated, for every kind of regional protection available): ARIPO (BW, GH, GM, KE, LR, LS, MW, MZ, NA, RW, SD, SL, ST, SZ, TZ, UG, ZM, ZW), Eurasian (AM, AZ, BY, KG, KZ, RU, TJ, TM), European (AL, AT, BE, BG, CH, CY, CZ, DE, DK, EE, ES, FI, FR, GB, GR, HR, HU, IE, IS, IT, LT, LU, LV, MC, MK, MT, NL, NO, PL, PT, RO, RS, SE, SI, SK, SM,

(54) Title: BARRIER ELEMENT TO BLOCK TRAFFIC AND/OR AS A SECURITY PRECAUTION INCLUDING A BALLAST COMPARTMENT

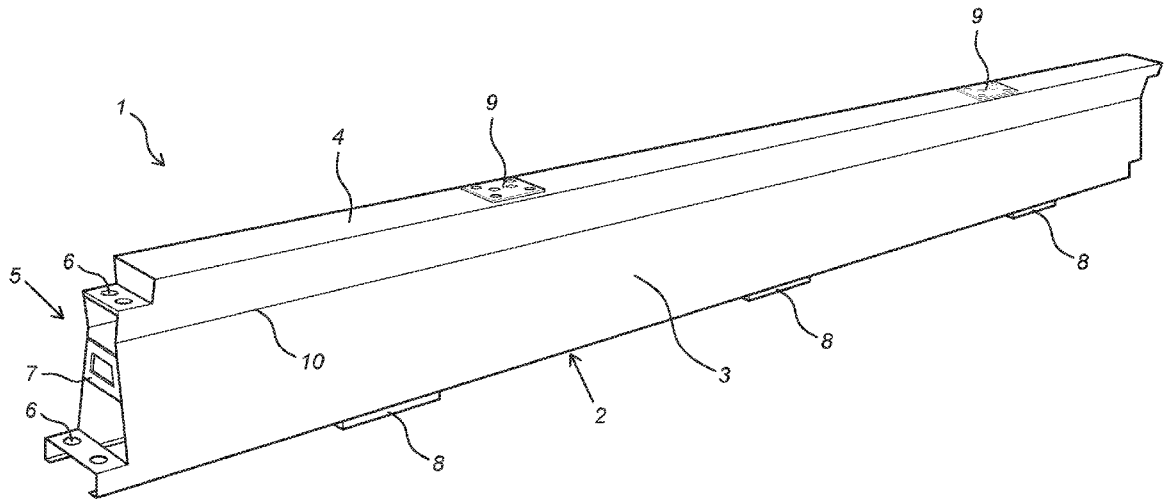

Fig. 1

(57) Abstract: The present invention relates to a barrier element to block traffic and/or as a security precaution, comprising: an elongated casing with two opposing longitudinal side walls and an upper wall; at least one casing support structure; and supports for resting on the ground/surface connected to the lower side of the elongate casing, wherein in the elongate casing a ballast compartment is incorporated that has a closed top, closed sides and an open bottom. The present invention also relates to a method for making ready for use of such a barrier element.



TR), OAPI (BF, BJ, CF, CG, CI, CM, GA, GN, GQ, GW,  
KM, ML, MR, NE, SN, TD, TG).

**Published:**

— *with international search report (Art. 21(3))*

**Barrier element to block traffic and/or as a security precaution including a ballast compartment**

The present invention relates to a barrier element to block traffic and/or as a security precaution, comprising: an elongated casing with two opposing longitudinal side walls and an, the two side walls joining, upper wall; at least one casing support structure located in the elongate casing and connecting to both the side walls; and supports for resting on the ground/surface connected to the lower side of the elongate casing and/or the lower side of the casing support structure. The invention also relates to a method for making ready for use of such a barrier element.

Barrier elements are installations set up to control or block traffic, e.g. during roadworks, temporary road closure, as a security precaution and/or as Hostile Vehicle Mitigation (HVM). For instance barrier elements for bounding carriageways are well known and widely used. These barrier elements are typically connected end-to-end to form an elongated barrier to protect traffic from roadside obstacles or hazards or to prevent vehicles from crossing over a median and striking an oncoming vehicle. Due to their elongated casing, these type of barrier elements may be individually freestanding or coupled freestanding and are preferably easy to deploy, making them suited for temporary use. As an alternative these type of barrier elements may also be more (semi-)permanently fixed to a roadbed (or other artificial construction like for instance a bridge or ramp) in situations where only a limited deflection distance is allowed. Such (semi-)permanently fixed barrier elements are also referred to as “minimum deflection barrier systems”.

The usage demands of such barrier elements are various. Preferably a barrier element is easy to install and remove, as well as easy to transport and store. These demands may for instance be provided by an elongated element substantially shaped as a traffic barrier, which traffic barrier may - or may not – be firmly connected to the ground or surface. A further elementary requirement of a barrier element is that it provides an essential blocking functionality as it has to be able to handle the forces exerted on the barrier element exerted by a vehicle that collides with the barrier element. The blocking functionality may be provided by the combination of various technical features like the shape of the barrier element, the weight (mass) of the barrier element, the connection(s) of the barrier element with

the surface and/or one or more adjoining barrier element(s). And even when one or more of the possible connections break, disconnect and/or detach due to a considerable force being exerted on the barrier element as a result of the impact of a vehicle onto the barrier element, the barrier element still is required to fulfil a blocking function. In order to reduce the severity of a collision, road side barriers often absorb at least part of the kinetic energy of a colliding object, specifically a vehicle, contacting a barrier. Common barrier elements hereby partially plastically deform as a method to dissipate the kinetic energy. The barrier must on the other hand be sufficiently rigid to retain its barrier function.

10

A problem is that the barrier elements with a higher weight provide a better functionality than lighter barrier element (on the basis of the inertia provided by the barrier element) but that heavier barrier elements are less easy to transport. The enhance functioning of the barrier element according the present invention is further a result of the increased friction between the heavier barrier and a road surface.

15

This problem is solved with a barrier element to block traffic and/or as a security precaution according the introduction of the description, wherein in the elongate casing a ballast compartment is incorporated that has a closed top, closed sides and an open bottom. Such a ballast compartment in itself does not substantially add to the weight of the barrier element but it enables to be filled with a curing material at a first location of use (or close to the first location of use of the barrier element). During the handling, transportation and storage in the initial life phase of the barrier element, being the phase wherein the barrier element is produced, stored and transported to the location of its first use, which may often comprise a long distance transportation and/or many transfer acts, the ballast compartment may stay empty (thus without holding any ballast). The barrier element with initial empty ballast compartment has the advantage that the handling is the barrier element is before filling the ballast compartment with the ballast simpler, cheaper as it requires - due to the lower weight - less from the handling, transportation and/or storage means. After arrival at the first location of (serious) use of the barrier element the ballast compartment may – in an upside down orientation of the barrier element - locally simply be filled with liquid curing ballast material so that the weight of the barrier element substantially grows,, which higher weight provides an

20

25

30

35

enhanced functionality compared to the lighter barrier element with unfilled ballast compartment due to the additional inertia of the barrier element. The barrier element according to the invention thus combines the advantages of a lighter barrier element in the first stage of its life cycle and the advantages of a heavier barrier element during the intended use of the barrier element.

An additional advantage of the barrier element according to the present invention is that the ballast compartment supports the dimensional stability of the construction of the barrier element, both in filled and in unfilled condition.

The closed top and closed sides are preferably fluid tight connected to each other and are forming together an inverted liquid-tight container with an open underside. This enables the filling of the turned upside down ballast compartment with a curing material without leakage of the curing material when in liquid state.

The ballast compartment may have an elongate ballast compartment casing as to distribute the additional weight of the ballast over a length of the barrier element. In a specific embodiment the length of the ballast compartment comprises the total length, or nearly the total length of the barrier element. In the latter case the end parts (e.g. including couplings) may be joined/untied with the outer ends of the sides of the ballast compartment.

The top and sides of the ballast compartment barrier element may be made out of steel made, more specific out of metal sheet material, as in practice steel sheet material is easy to obtain at reasonable prices. Also during the production of prior art traffic barriers and barrier elements often use is made of steel plate material so the production of the barrier element according to the present invention will normally fit the production facilities of traffic barrier and barrier element producers without the demand for substantive changes of adaptation.

In a specific embodiment at least one of the supports is connected to the underside of two opposed sides of the ballast compartment. Again such an additional connection of parts adds to the structural strength of the construction of the barrier element but as a further advantage hardened ballast material in the ballast compartment may be secured/locked in its position as one or more supports may

“lock” the hardened ballast material in its position. The support(s) work as a blockade against the hardened ballast material leaving the ballast compartment.

5 Furthermore it is advantageous to connect at least one casing support structure to the ballast compartment. Again such an additional connection will enhance the stability and strength of the construction of the barrier element. In case of considerable forces exerted onto the barrier element these forces will better be absorbed in case the support structure is “backed up” by the ballast filled ballast compartment.

10

The ballast compartment may also be provided with one or more internal protrusions. The advantage of such protrusion(s) may be that - as also referred to in relation to the compartment attached supports above - hardened ballast material in the ballast compartment may be secured/locked in its position as one or more 15 protrusions may hold the hardened ballast material form-fitting in its position. The protrusion(s) may work as a blockade against the hardened ballast material leaving the ballast compartment.

To enable coupling of the barrier element with other barrier elements or other 20 objects the ends of the elongated casing may be provided with couplings. These may be connected to the ballast compartment (or alternatively formulated to a side and/or the top of the ballast compartment to provide additional strength and stability of the structure of both, the individual barrier elements, as well as a row of at least two mutual coupled barrier elements).

25

As the blocking functionality of the barrier element on the sides is relevant the ends of the elongated casing may be chamfered. This also provides additional strength to the construction and prevents the chance of unwanted contact of road users (pedestrians, cyclists, guards) with the barrier element.

30

The present invention relates not only to the barrier element with an empty ballast compartment as well as the barrier element wherein the ballast compartment is filled with a curing material. After the ballast compartment being filled with hardened ballast material the barrier element is suited to be used in circumstances 35 in wherein the loads exerted onto the barrier element may be heavy.

A suited curing material may be concrete as it is easy and relatively cheap to obtain and prepare at most locations in the world. Further advantages of concrete is that it is relative heavy and it is also very suitable for absorbing pressure loads.

5 Furthermore an additional reinforcement in the concrete (e.g. a (metal) fibre) to make the concrete suited to withstand substantial tension forces is superfluous as the ballast compartment will function as an external length that may be provided by the ballast compartment.)

10 The barrier element according the present invention may also be provided with at least one, but preferably at least two, lifting couplings (e.g. in the form of openings in the top providing access to a gripping element) to enable to attach a manipulator (e.g. a crane) for instalment and/or removal of the barrier element.

15 The present invention also provides a method for making ready for use of a barrier element according to the present invention, comprising the method steps: A) placing the barrier element is brought in an inverted position; B) filling the ballast compartment with a liquid curing material; C) hardening the curing material; and D) turning the barrier element back to a working position. The filling of the ballast compartment is easy via the open bottom and will increase the weight and stability  
20 of the barrier element enhancing its usage options. The method is very easy to be performed at any location and also requires very limited skill.

The present invention will be further elucidated on the basis of the non-limitative exemplary embodiments shown in the following figures, herein shows:

25 figure 1 a perspective view of a barrier element according the present invention; figure 2 a perspective bottom view of the barrier element shown in figure 1; and figure 3 a partially cut away perspective view of the barrier element shown in the figures 1 and 2.

30 Figure 1 shows a barrier element 1 with an elongate casing 2 with a longitudinal side wall 3, an upper wall 4 and an end part 5 with coupling openings 6. From a casing support structure that is located in the elongate casing 2 only casing support structure part 7 on an end part 5 is visible in this figure. On the lower side of the  
35 barrier element 1 supports 8 are attached for resting on the ground/surface. On the

upper wall 4 connectors 9 enable the attachment of lifting means (e.g. a crane) and or the attachment of other equipment parts (e.g. a raised rails). The side wall 3 has an inward angle 10 reducing the chance of a vehicle coming into contact with the barrier element 1 being launched across the barrier element 1.

5

In figure 2 the barrier element 1 from figure 1 is shown from the bottom. The elongate casing 2 has an open bottom 11 connecting to a ballast compartment as will be more clearly depicted in figure 3. The supports 8 of the barrier element 1 are partially blocking the opening 11 in the bottom of the barrier element 1. On one end  
10 side of the barrier element 1 a single coupling opening 6 is visible and on the opposite end of the barrier element 1 coupling pins 12 are visible. The coupling pins 12 of a barrier element 1 will fit the coupling openings 6 of an adjoining barrier element 1 to link the adjoining barrier elements 1.

15 In figure 3 the barrier element 1 is depicted in a cut away perspective view wherein the front longitudinal side wall is omitted. In the represented situation there is a clear view on a ballast compartment 20 that is embedded in the interior of the barrier element 1. This ballast compartment 20 is open on the lower side (see figure 2) and the supports 8 are attached to two opposing sides (of which only one  
20 is visible here) 21. Also ends 22 and the top 23 of the ballast compartment 20 are closed so that no liquid curing material will flow out the ballast compartment 20 when turned upside down. After curing the ballast material is held in the ballast compartment 20 by the supports 8.

25 Also visible in figure 3 are casing support structures 24 that are (at least partially) connected to the ballast compartment 20 to provide additional stability to the construction of the barrier element 1. Also the coupling openings 6 and, on the opposite side of the barrier element 1, the coupling pins 12 are clearly visible. Again here it is advantageous in the coupling openings 6 and coupling pins 12  
30 receive support from the ballast compartment 20 to ensure additional strength and stability.

## Claims

1. Barrier element to block traffic and/or as a security precaution, comprising:
- an elongated casing with two opposing longitudinal side walls and an, the  
5 two side walls joining, upper wall;
  - at least one casing support structure located in the elongate casing and connecting to both the side walls; and
  - supports for resting on the ground/surface connected to the lower side of the elongate casing and/or the lower side of the casing support structure,
- 10 wherein in the elongate casing a ballast compartment is incorporated that has a closed top, closed sides and an open bottom.
2. Barrier element according to claim 1, **characterised in that** the closed top and closed sides of the ballast compartment are liquid tight.
- 15
3. Barrier element according to claim 1 or 2, **characterised in that** the ballast compartment has an elongate ballast compartment casing.
4. Barrier element according to any of the preceding claims, **characterised in**  
20 **that** the top and sides of the ballast compartment are made out of metal sheet material.
5. Barrier element according to any of the preceding claims, **characterised in**  
25 **that** at least one of the supports is connected to the underside of two opposed sides of the ballast compartment.
6. Barrier element according to any of the preceding claims, **characterised in**  
**that** at least one casing support structure is connected to the ballast compartment.
- 30 7. Barrier element according to any of the preceding claims, **characterised in**  
**that** the ballast compartment is provided with at least one internal protrusion.
8. Barrier element according to any of the preceding claims, **characterised in**  
**that** the ends of the elongated casing are provided with couplings.

9. Barrier element according to claim 8, **characterised in that** the couplings are connected to the ballast compartment.
10. Barrier element according to any of the preceding claims, **characterised in**  
5 **that** the ends of the elongated casing are chamfered.
11. Barrier element according to any of the preceding claims, **characterised in**  
**that** the ballast compartment is filled with a curing material.
- 10 12. Barrier element according to claim 12, **characterised in that** the curing material is concrete.
13. Method for making ready for use of a barrier element, comprising the method steps:
- 15 A) placing a barrier element according to any of the claims 1 – 10 in an inverted position;  
B) filling the inverted ballast compartment with a liquid curing material;  
C) hardening the curing material; and  
D) turning the barrier element back to a working position.

1/3

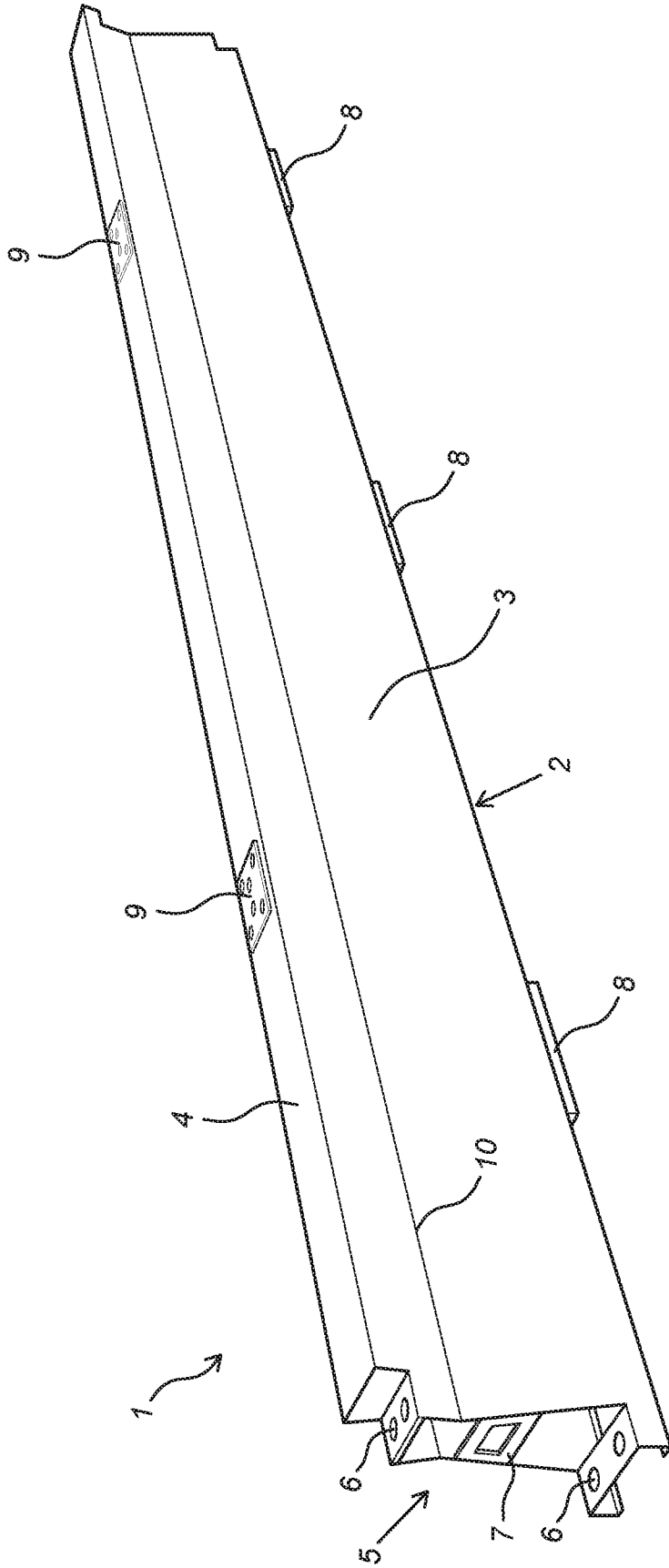

Fig. 1

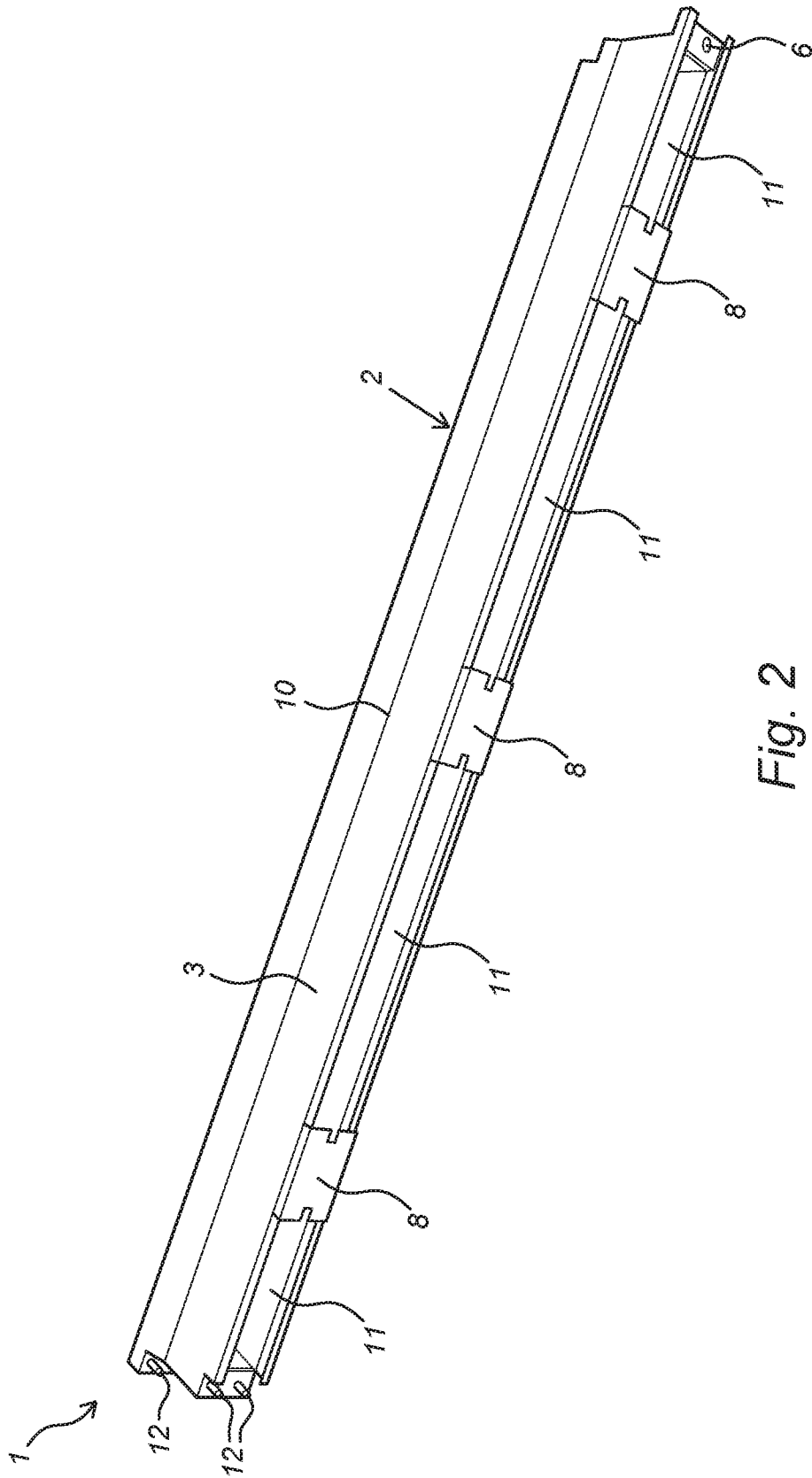

Fig. 2

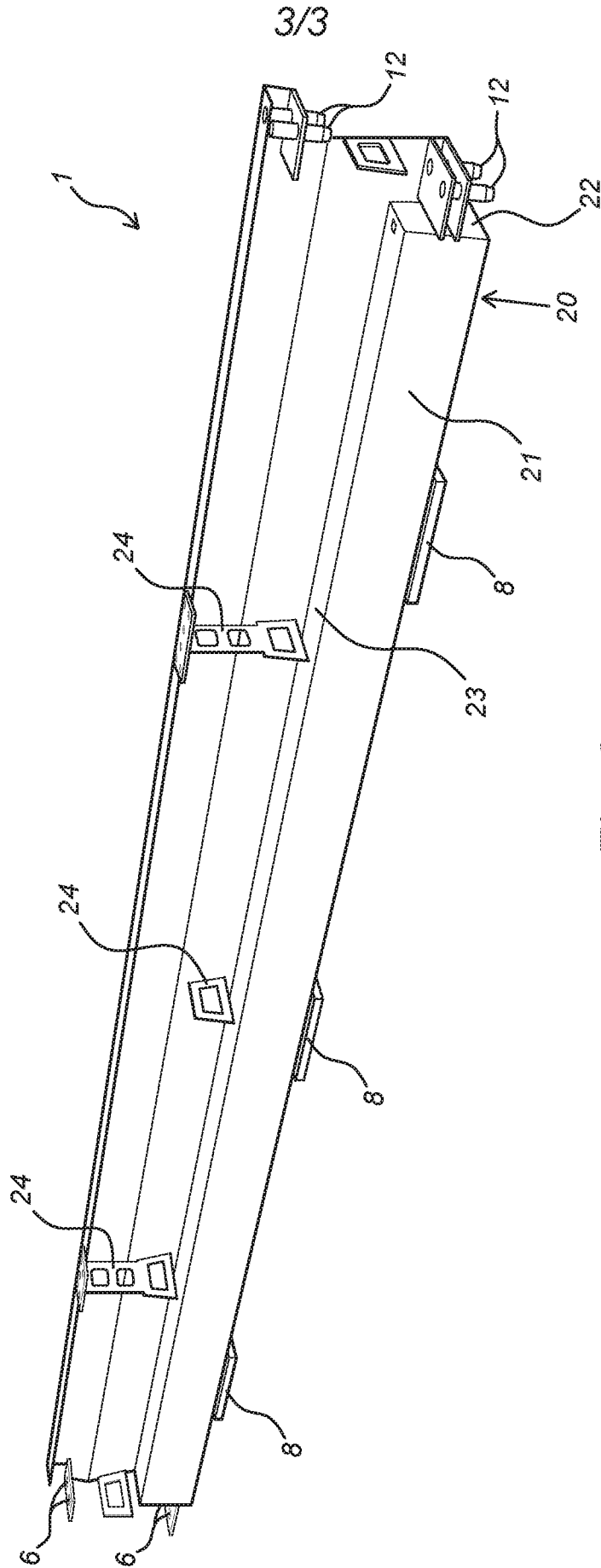

Fig. 3

**INTERNATIONAL SEARCH REPORT**

International application No  
PCT/NL2021/050016

**A. CLASSIFICATION OF SUBJECT MATTER**  
INV. E01F15/08  
ADD.

According to International Patent Classification (IPC) or to both national classification and IPC

**B. FIELDS SEARCHED**

Minimum documentation searched (classification system followed by classification symbols)  
E01F

Documentation searched other than minimum documentation to the extent that such documents are included in the fields searched

Electronic data base consulted during the international search (name of data base and, where practicable, search terms used)  
EPO-Internal, WPI Data

**C. DOCUMENTS CONSIDERED TO BE RELEVANT**

Category*	Citation of document, with indication, where appropriate, of the relevant passages	Relevant to claim No.
X	WO 2015/003213 A1 (SAFEROADS PTY LTD [AU]) 15 January 2015 (2015-01-15)	1
A	the whole document	2-13
X	US 5 054 954 A (COBB LINCOLN C [CA] ET AL) 8 October 1991 (1991-10-08)	1
A	the whole document	2-13
A	NL 2 013 140 B1 (LAURA METAAL EYGELSHOVEN B V [NL]) 1 August 2016 (2016-08-01) page 6, lines 26-32; figures 1-4	1-13
A	EP 0 452 893 A1 (SPS SCHUTZPLANKEN GMBH [DE]) 23 October 1991 (1991-10-23) column 5, lines 34-50; figures 3,4	1-13

Further documents are listed in the continuation of Box C.

See patent family annex.

\* Special categories of cited documents :

"A" document defining the general state of the art which is not considered to be of particular relevance

"E" earlier application or patent but published on or after the international filing date

"L" document which may throw doubts on priority claim(s) or which is cited to establish the publication date of another citation or other special reason (as specified)

"O" document referring to an oral disclosure, use, exhibition or other means

"P" document published prior to the international filing date but later than the priority date claimed

"T" later document published after the international filing date or priority date and not in conflict with the application but cited to understand the principle or theory underlying the invention

"X" document of particular relevance; the claimed invention cannot be considered novel or cannot be considered to involve an inventive step when the document is taken alone

"Y" document of particular relevance; the claimed invention cannot be considered to involve an inventive step when the document is combined with one or more other such documents, such combination being obvious to a person skilled in the art

"&" document member of the same patent family

Date of the actual completion of the international search

26 February 2021

Date of mailing of the international search report

12/03/2021

Name and mailing address of the ISA/

European Patent Office, P.B. 5818 Patentlaan 2  
NL - 2280 HV Rijswijk  
Tel. (+31-70) 340-2040,  
Fax: (+31-70) 340-3016

Authorized officer

Flores Hokkanen, P

# INTERNATIONAL SEARCH REPORT

Information on patent family members

International application No PCT/NL2021/050016
---

Patent document cited in search report	Publication date	Patent family member(s)	Publication date
WO 2015003213	A1	15-01-2015	AU 2014289966 A1 21-01-2016
			AU 2018100904 A4 02-08-2018
			AU 2018204783 A1 19-07-2018
			CA 2915899 A1 15-01-2015
			EP 3019665 A1 18-05-2016
			US 2016145819 A1 26-05-2016
			WO 2015003213 A1 15-01-2015
-----			
US 5054954	A	08-10-1991	NONE
-----			
NL 2013140	B1	01-08-2016	
EP 0452893	A1	23-10-1991	AT 107984 T 15-07-1994
			EP 0452893 A1 23-10-1991
-----			