

F. Latta,

Compound Steam Engine.

N^o 55,122.

Patented May 29, 1866.

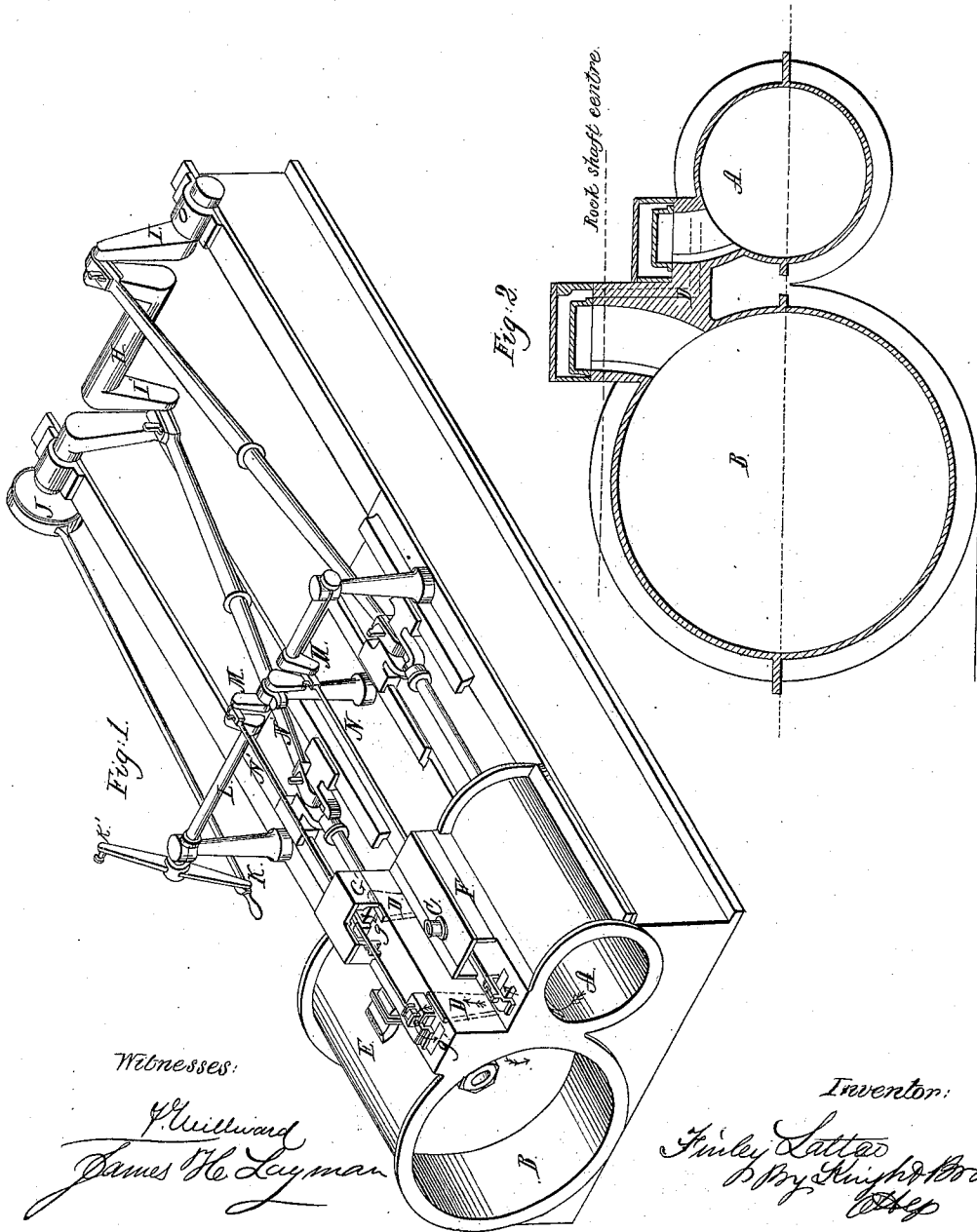

UNITED STATES PATENT OFFICE.

FINLEY LATTA, OF CINCINNATI, OHIO.

IMPROVEMENT IN STEAM-ENGINES.

Specification forming part of Letters Patent No. 55,122, dated May 29, 1866.

To all whom it may concern:

Be it known that I, FINLEY LATTA, of Cincinnati, Hamilton county, Ohio, have invented a new and useful Improvement in Steam-Engines; and I do hereby declare the following to be a full, clear, and exact description thereof, reference being had to the accompanying drawings, making part of this specification.

My improvement relates to the class of steam-engines called "double-worked," being those in which the escape-steam from a high-pressure cylinder is used in an expanded form in a cylinder of larger area before final exhaustion; and my invention consists in a peculiar arrangement by which the cylinders can be closely connected side by side, or even cast in one piece, and be made to communicate directly at their corresponding ends by means of short steam-passages, and by which the valves of both cylinders can be operated by a single eccentric and rock-shaft.

In the accompanying drawings, Figure 1 is a perspective view of a double-worked steam-engine embodying my improvements. Fig. 2 is cross-section of the two cylinders.

The small cylinder A and the large cylinder B are arranged side by side as closely as practicable. With this object in view I prefer to form both cylinders, together with their steam-ports, in a single casting, as represented in the accompanying illustration.

The small cylinder A receives steam from the boiler through a pipe, C, and exhausts into the larger cylinder through passages D D', the cylinder B in its turn exhausting through a pipe or passage, E, either into the open air or into a condenser, as may be preferred.

The valve-chests of the respective cylinders may be single, as at F, or double, as at G G'.

The cylinder A exhausts, by flaring passages D D', into the valve-chests G G', which chests, together with their ports *g g'*, are made of somewhat greater capacity than the corresponding parts of the cylinder A.

The pistons of both cylinders are pitmaned

to a common crank-shaft, H, whose cranks I I' point in diametrically opposite directions. The crank-shaft H is provided with a single customary eccentric, I, which, being connected either to the direct wrist K or to the reverse wrist K' of a rock-shaft, L, serves to work at the same time both sets of valves through the medium of suitable arms M M' and rods N N', of usual construction.

The arrangement possesses several very decided advantages over double-worked steam-engines of the forms hitherto employed.

The cylinders being cast together, side by side, a saving of weight, metal, and steam is effected, the communication being made directly from a given end of the smaller cylinder to the corresponding end of the larger one, insuring the least possible loss of heat by radiation. Moreover the two cylinders cannot get out of line by sagging. The described arrangement of valve-chests in juxtaposition also acts to economize material, space, and steam.

The inequality of effective area on the two sides of the common reciprocating piston, due to the space taken up by the rod, is, in the above arrangement, partly neutralized, because when the sole of one piston is in action the rod side of the other piston is in action.

By working the steam into the similar or corresponding end of the larger cylinder and the pistons in reverse directions I am enabled to make one eccentric and one rock-shaft serve for both sets of valves.

I claim herein as new and of my invention—

The arrangement of the direct steam-passages, in combination with steam-cylinders of unequal diameter, in a steam-engine, adapted to operate as and for the purposes set forth.

In testimony of which invention I hereunto set my hand.

FINLEY LATTA.

Witnesses:

GEO. H. KNIGHT,
JAMES H. LAYMAN.