



(19) **United States**

(12) **Patent Application Publication**
Maute

(10) **Pub. No.: US 2002/0005279 A1**

(43) **Pub. Date: Jan. 17, 2002**

(54) **USE OF A HEAT EXCHANGER**

Publication Classification

(75) **Inventor: Alexander Maute, Hechingen-Stetten (DE)**

(51) **Int. Cl.⁷ F28D 1/00; F28F 1/00**

(52) **U.S. Cl. 165/148; 165/177**

Correspondence Address:

Dreiss, Fuhlendorf, Steimle & Becker
Postfach 10 37 62
D-70032 Stuttgart (DE)

(57) **ABSTRACT**

(73) **Assignee: Joma-Polytec Kunststofftechnik GmbH, Robert-Bosch-Strasse 4, D-72411 Bodelshausen (DE)**

The invention concerns a use of a heat exchanger for temperature control or air conditioning in rooms. The heat exchanger has a media guiding body having two groups of crossing channels (24,46) or (110,112) for media to be separately guided, wherein one channel group (24;110) is formed like a pipe and the other channel group (46;112) is formed like a shaft, wherein the latter channel group (46;112) is formed by bridges (30;126) provided on the outside at a distance from one another and oriented transverse to the pipe axis, wherein the pipe-like channels (24;110) and the bridges (30;126) are commonly produced from at least one formed sheet (140) consisting of thermoplastic material (32) or of a thermally conducting metal.

(21) **Appl. No.: 09/897,939**

(22) **Filed: Jul. 5, 2001**

(30) **Foreign Application Priority Data**

Jul. 14, 2000 (DE)..... 100 34 568.9

Nov. 18, 2000 (DE)..... 100 57 240.5

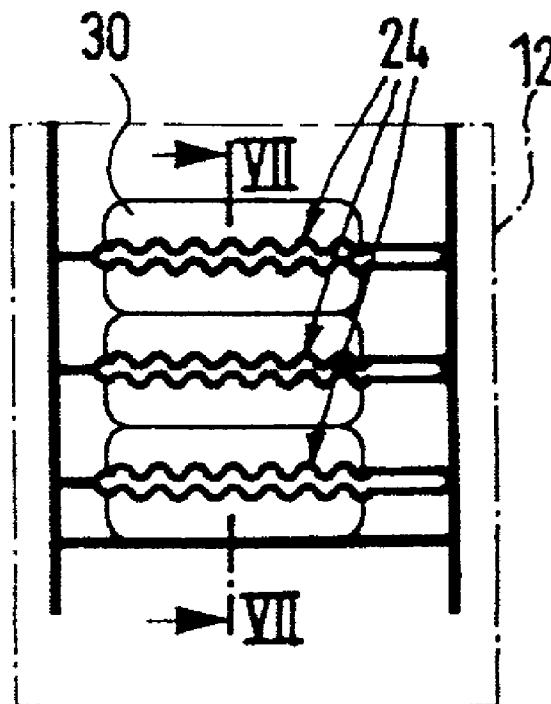

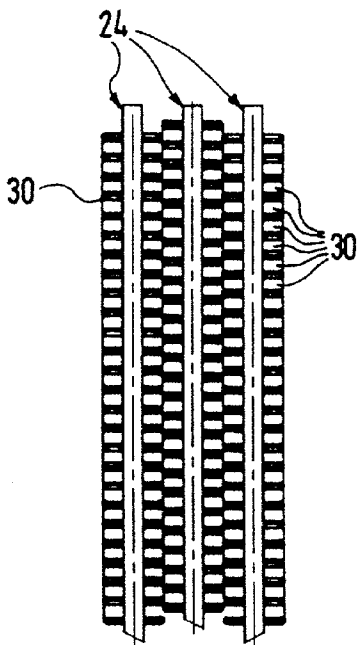

Fig.7

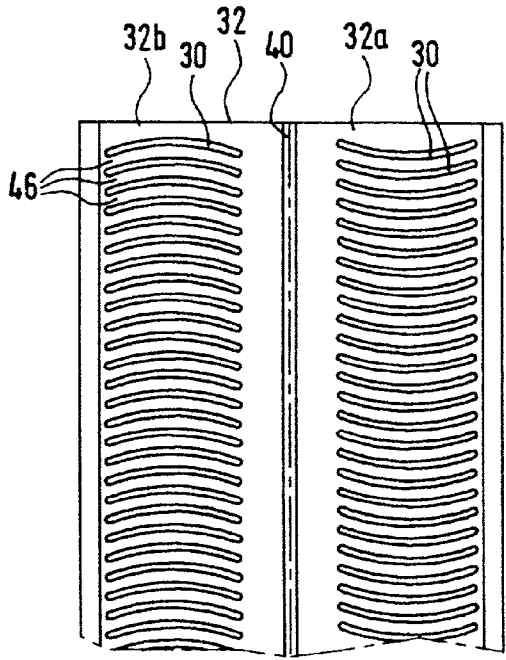

Fig.5

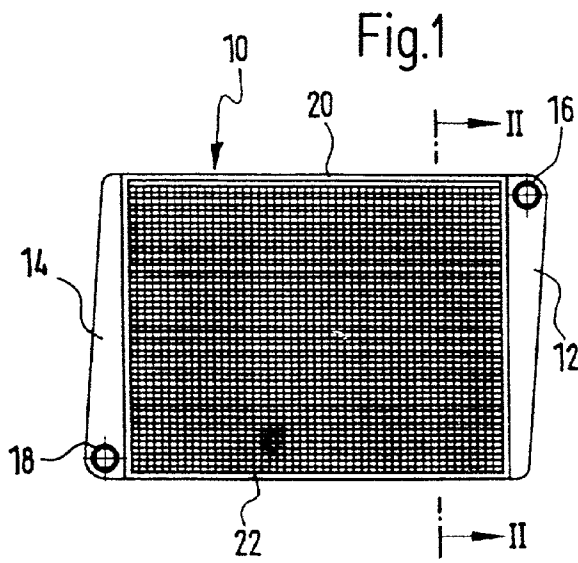

Fig.1

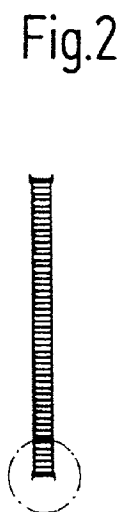

Fig.2

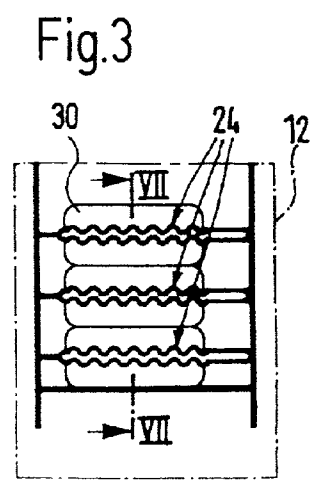

Fig.3

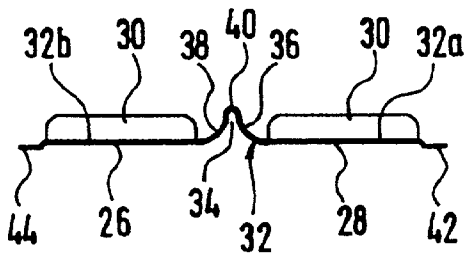

Fig. 4a

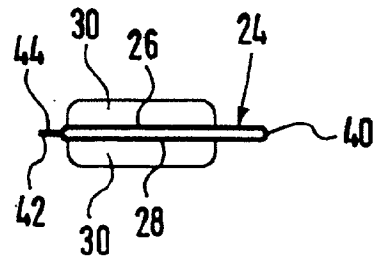

Fig. 6a

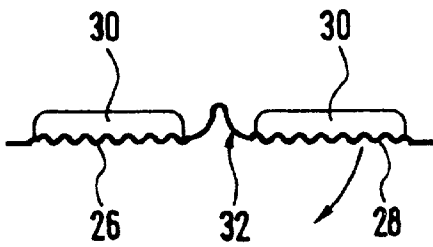

Fig 4b

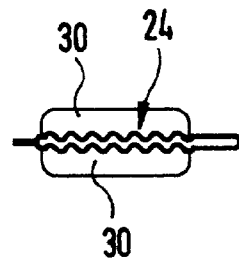

Fig. 6b

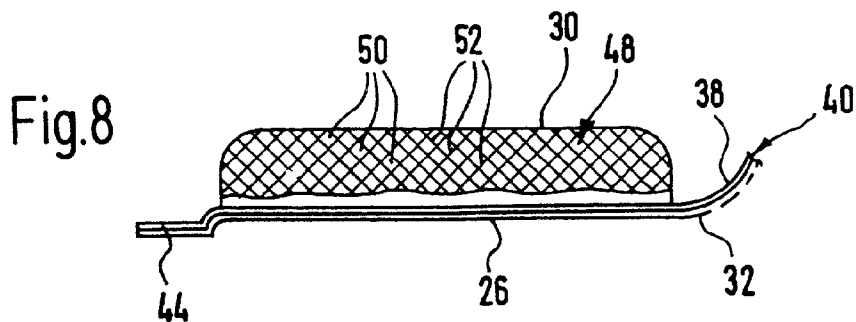

Fig. 8

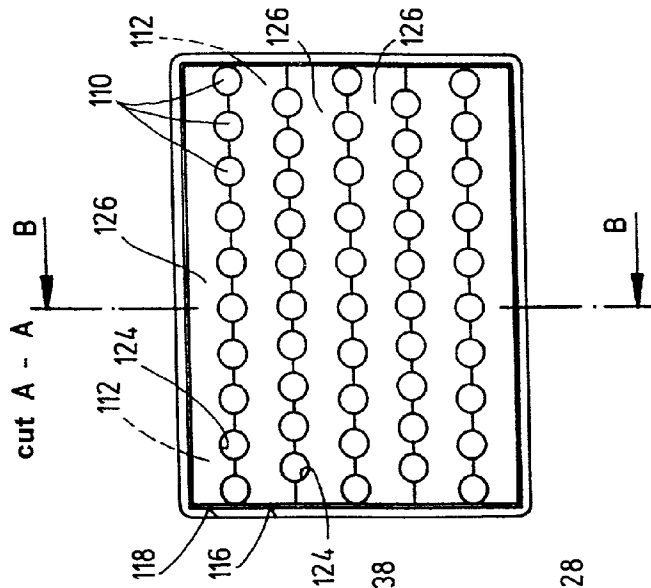

Fig.10

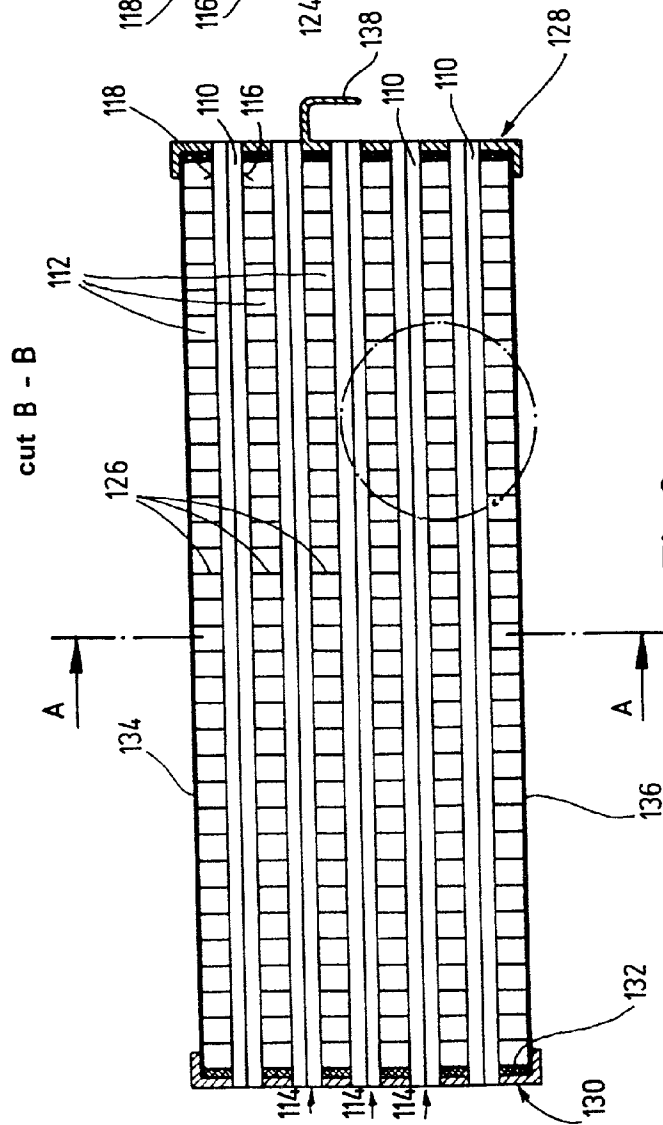

Fig.9

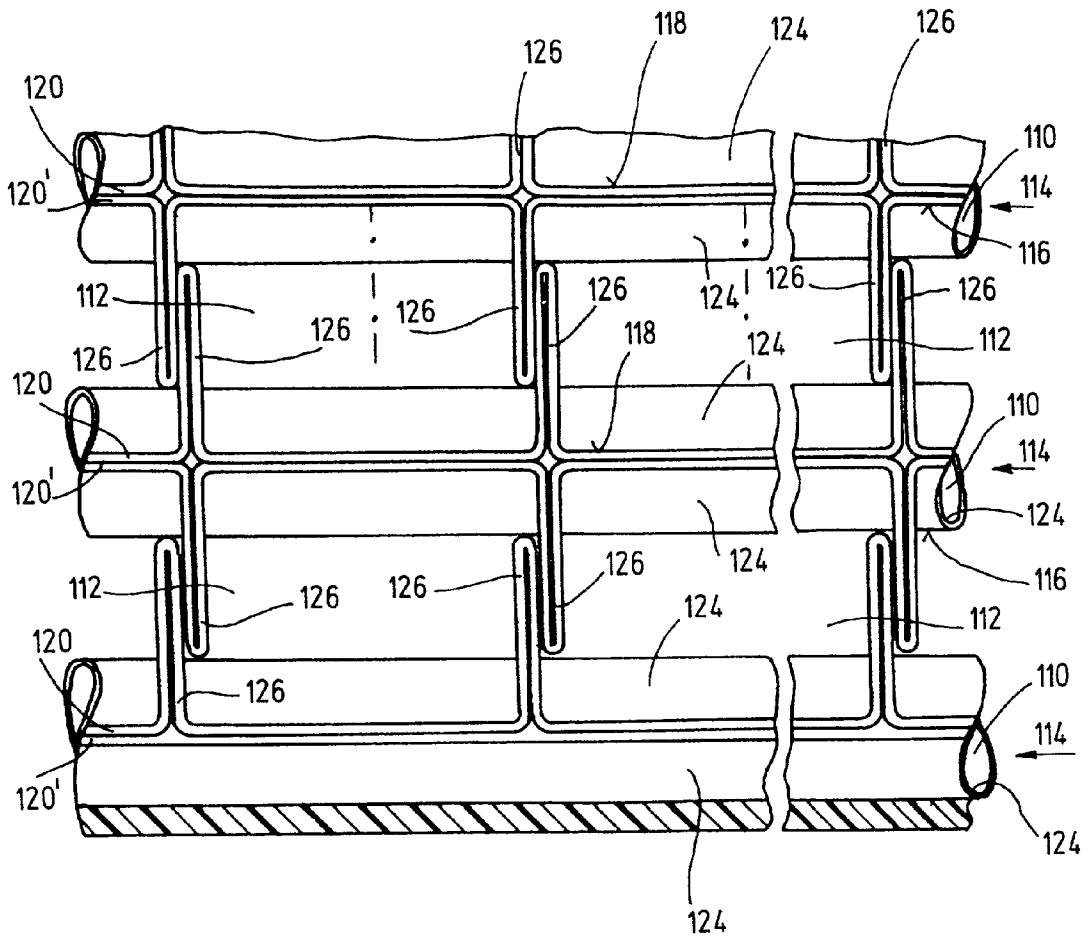
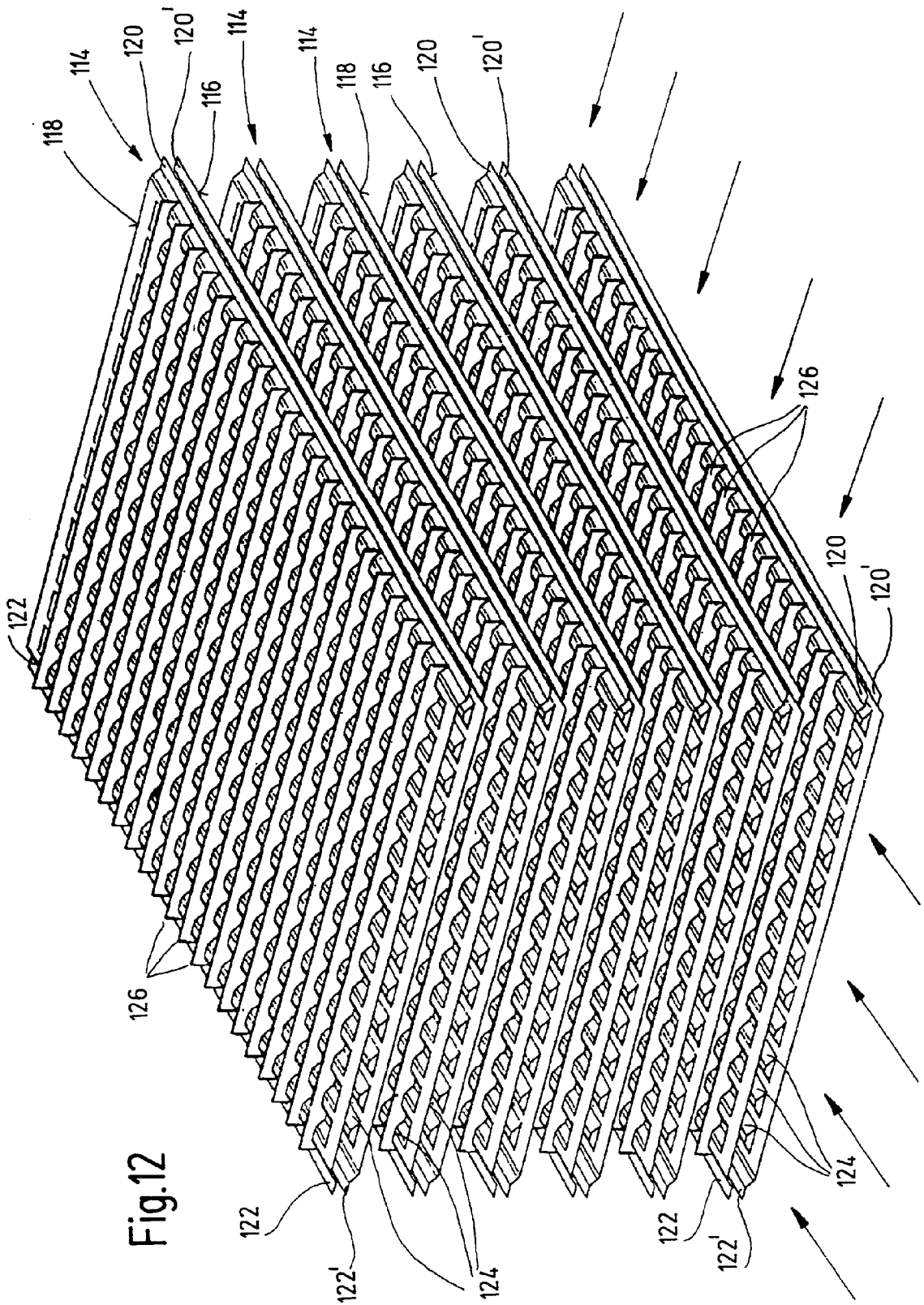

Fig.11



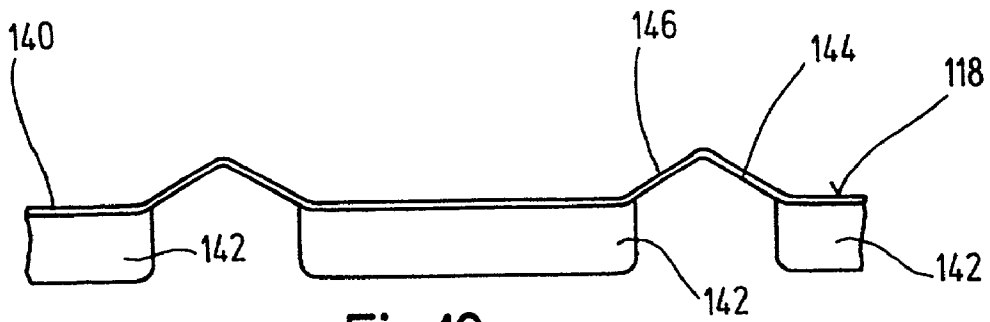

Fig.13

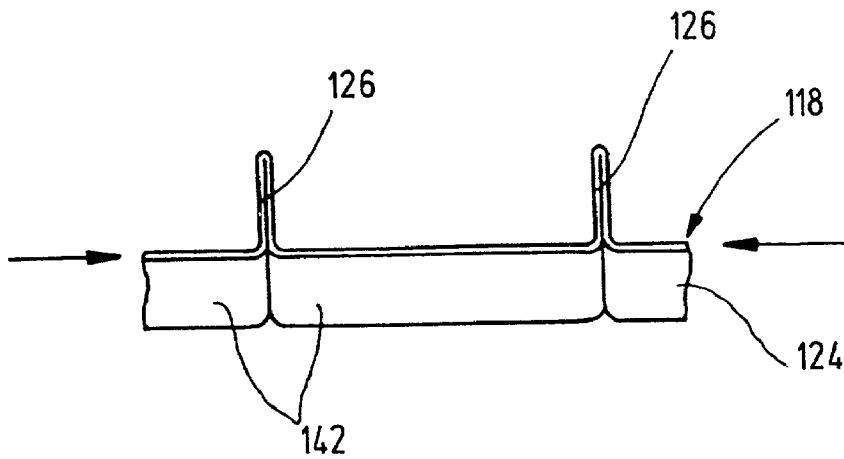

Fig.14

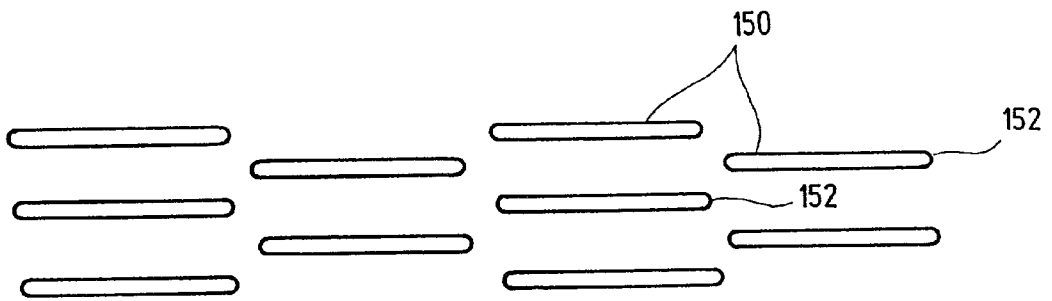

Fig.15

USE OF A HEAT EXCHANGER

[0001] This application claims Paris Convention priority of DE 100 34 568.9 filed Jul. 14, 2000 and of DE 100 57 240.5 filed Nov. 18, 2000 the complete disclosure of which are hereby incorporated by reference.

BACKGROUND OF THE INVENTION

[0002] The invention concerns the use of a heat exchanger.

[0003] Known heat exchangers of this construction are designed as coolers for the cooling water or lubricant of combustion engines (see DE 199 39 531 C1) and also as aggregate for condenser dryers (see DE 198 38 525 A1) and are characterized by low weight and a construction which permits easy and inexpensive manufacture.

SUMMARY OF THE INVENTION

[0004] It is the object of the present invention to find new fields of application for heat exchangers of this type, wherein, in accordance with the invention, the heat exchanger is used for temperature control or air conditioning control in rooms.

[0005] The use of the heat exchanger thereby facilitates e.g. the cooling and heating of passenger compartments in vehicles or rooms in buildings depending on the combination of the corresponding media which are guided through the channels of the media guiding body, formed from a shaped plastic sheet.

[0006] If refrigerant is guided through the pipe-like channels to dehumidify and cool the air, the heat exchanger constitutes a condenser while same assumes the function of a radiator for passage of heated cooling water through these channels, to heat the room air in buildings or in a passenger compartment.

[0007] The drawing shows embodiments of heat exchangers which can be used in accordance with the invention.

BRIEF DESCRIPTION OF THE DRAWING

[0008] FIG. 1 shows a front view of a heat exchanger originally forming a cooler for the cooling water of a combustion engine which can be used in accordance with the invention as a radiator for heating a passenger compartment;

[0009] FIG. 2 shows a cross-section of the heat exchanger along line II-II of FIG. 1;

[0010] FIG. 3 shows a portion, indicated in FIG. 2 by a dash-dotted circle, in an enlarged scale;

[0011] FIG. 4a shows a cross-section through a first plastic sheet for forming a liquid pipe having laminated bridges;

[0012] FIG. 4b shows a cross-section through a second plastic sheet for forming a liquid pipe having laminated bridges;

[0013] FIG. 5 shows a top view onto the plastic sheet in a shortened representation;

[0014] FIG. 6a shows a cross-section through a liquid pipe formed from a sheet according to FIG. 4a;

[0015] FIG. 6b shows a cross-section through a liquid pipe formed from a sheet according to FIG. 4b;

[0016] FIG. 7 shows a section along line VII-VII of FIG. 3; and FIG. 8 shows the left half of FIG. 4a in a highly enlarged and partly broken-away representation;

[0017] FIG. 9 shows a longitudinal section through a heat exchanger provided for air conditioning of a room through regulation of the room air humidity, along line B-B of FIG. 10;

[0018] FIG. 10 shows a cross-section through the heat exchanger along line A-A of FIG. 9;

[0019] FIG. 11 shows a section of the representation of FIG. 9, indicated by a dash-dotted circle, in a highly enlarged and shortened scale;

[0020] FIG. 12 shows a schematic representation of a plate packet of the heat exchanger forming the media guiding body according to FIGS. 9 and 10;

[0021] FIG. 13 shows a partial longitudinal section through a plate part of aluminum sheet, pre-formed as a blank;

[0022] FIG. 14 shows a representation of the plate part according to FIG. 13, in a pushed together state;

[0023] FIG. 15 shows a schematic sectional view of the mutually offset arrangement of bridge parts.

DESCRIPTION OF THE PREFERRED EMBODIMENT

[0024] The heat exchanger shown in FIG. 1 constitutes e.g. a radiator for heating a passenger compartment of a vehicle driven by a combustion engine. It comprises a conventional frame 10 whose lateral frame legs 12 and 14 are formed like a box. The frame leg 12 contains a water supply chamber which can be connected to the return cooling water of the combustion engine via an inlet nozzle 16, while the frame leg 14 contains a water outlet chamber which can be connected to a water pump of the combustion engine via an outlet nozzle 18.

[0025] Both frame legs 12,14 are connected to one another via an upper and lower frame leg 20 and 22, preferably having a U-shaped cross-section, such that the corners are rigid.

[0026] A heating system is provided within the frame 10 which is fashioned from a plurality of individual liquid or water pipes 24 which extend e.g. in a horizontal direction and are disposed one on top of the other. Their ends communicate with the two chambers of the frame legs 12,14, as is known per se, wherein the sealed arrangement of the water pipes 24 of the heating network can be realized on the frame legs 12,14 by means of casting resin or in any other suitable fashion. The frame legs 12,14 and the liquid or water pipes 24 integrated in the frame 10 form a media guiding body.

[0027] The construction of the water pipes 24 and their manufacture is explained in detail below.

[0028] According to FIG. 6a and 6b, the water pipes 24 preferably have the cross-section of a flat pipe and are provided in the frame 10, disposed one on top of the other in a common plane, such that their flat pipe wall parts 26 and

28 are disposed one on top of the other. On their outer sides, both pipe wall parts **26** and **28** have laminated bridges **30** which extend in the longitudinal direction of the pipe at a separation from one another and transverse to the axial direction of the pipe to form shaft-like channels such that the media flowing through the heat exchanger cross by each other.

[0029] The water pipes **24** consist of pressure-resistant, hydrolysis-resistant, temperature-suited highly rigid plastic material, such as PA 6.6, PEI, PEEK, PAI or PPS and are formed in two working steps from one plastic sheet **32**, preferably 0.30 mm thick.

[0030] This plastic sheet **32** is thermally formed (e.g. in a deep-drawing tool under application of an underpressure) into the shape shown in FIGS. **4a** and **4b**.

[0031] This plastic sheet **32** therefore comprises two sheet halves **32a** and **32b** which are flexibly connected to one another via a depression **34** having the shape of a reverse groove and extending in the longitudinal direction of the sheet.

[0032] The side walls **36**, **38** of this depression **34** continuously widen towards the outside and therefore have the cross-section of a partial circle. The bottom **40** of this depression **34** preferably has a semi-circular cross-section.

[0033] The cross-sectional shape of the groove-like depression **34** ensures that the plastic sheet **32** can be folded such that both sheet halves **32a** and **32b** are aligned, one on top of the other (see FIGS. **6a** and **6b**) and the pipe wall parts **26,28** extend in parallel up to the longitudinal-side connecting edge formed by the groove bottom **40**, thereby making the pipe cross-section constant over the entire pipe width.

[0034] Each sheet half **32a** and **32b** has an external, longitudinal edge piece **42**, **44** which is stepped-off from the adjacent pipe wall part **26** or **28** such that, when both sheet halves **32a** and **32b** register, the pipe wall parts extend in parallel with respect to one another. After folding the plastic sheet **32**, the longitudinal edge pieces **42** and **44** must merely be sealingly connected together e.g. through gluing, folding, or preferably through welding in order to complete the water pipes **24**.

[0035] The deep-drawing or, optionally, embossing process imparts a U-shaped cross-section to the laminated bridges **30**, comprising two bridge wall parts. Same are connected to one another after thermal treatment of the plastic sheet **32** and thereby reinforced to prevent a sideward distensioning of the bridges **30** and thereby a reduction in the cross-section of the shaft-like air channels **46** defined by the bridges **30** and associated reduction in the warm air throughput when the heat exchanger is operated with a high operating pressure in the water pipes **24**.

[0036] The laminated bridges **30** can be perpendicular to the longitudinal axis of the pipe. Preferably, however, the bridge is slightly bent like an arc (see FIG. **5**) wherein, in the folded state of the plastic sheet **32**, the bridges **30** are supported, one on top of the other as indicated in FIG. **7**.

[0037] In this manner, the bridges **30** can have half the height which they would have otherwise had were they straight and directly supported on the neighboring water pipe **24**. In the latter case, the bridges **30** would have to be

formed on both sheet halves **32a** and **32b**, offset from one another and leaving a gap, wherein engagement of the bridges **30** of the one sheet half between those of the other sheet half would then result in a reduction in the cross-section of the warm air channels.

[0038] As shown in FIG. **4b** and **6b**, the constructive difference in this embodiment of the plastic sheet **32** compared to that of FIG. **4a** and **6a** is the fact that the flat sided pipe wall parts **26,28** have a wavy cross-section wherein the two wave lines preferably extend parallel to one another. In this fashion, the temperature of the air to be heated can be considerably increased due to the surface enlargement obtained for constant cross-section of the flat pipe.

[0039] As shown in FIG. **8**, the plastic sheet **32** has a reinforcing insert in the form of a grid system **48** which increases its rigidity and which can consist of glass or carbon fibers having a length of preferably 30 mm. Fibers of a material having good tear-resistant properties, such as aramide are particularly suitable.

[0040] The grid system **48** is thereby oriented in the plastic sheet **32** such that, for forming the bridges **30**, the net openings **50** have a diamond shape in the vertical direction of the bridges. The extension of the net fibers **52** at an inclined angle of 45° provides the grid system **48** with great elasticity and stretchability during thermal formation of the plastic sheet **32**.

[0041] Alternatively, the plastic sheet can be reinforced with short or long fibers, wherein short fibers can be advantageously used for relatively large bridge heights and long fibers, e.g. grid systems, for relatively short bridge heights.

[0042] The frame legs **20,22** have considerable importance in the described inventive embodiment of the water pipes **24** because they suppress distension of the water pipes **24** in the vertical direction of their bridges **30** for corresponding operating pressures.

[0043] The heat exchanger shown in FIGS. **9** through **15** comprises e.g. five horizontal planes of room air channels **110** preferably having an approximately cylindrical cross-section through which room air flows and which extend in parallel at a radial separation from one another and are preferably offset from one plane to the other, thereby forming gaps. A total of six planes of cooling air channels **112** having a rectangular or shaft-like cross-section extend transverse to the room air channels **110** and parallel to their planes.

[0044] Both types of channels **110** and **112** are preferably formed by rectangular plates **114** of a plate packet forming a media guiding body, which are stacked on top of each other and are themselves produced from two plate parts **16** and **18** of identical shape which are disposed symmetrically with respect to one another (see FIG. **11** and **12**).

[0045] In the present case, these plate parts **116**, **118** are manufactured, as a single piece, from a sheet of thermoplastic material, preferably polypropylene. They can also be formed from a single metal sheet having good heat-conducting properties, preferably aluminum.

[0046] Each plate part **118** is sealingly connected along its two opposing longitudinal edge portions **120** and **122** to those (designated by **120'** and **122'**) of the plate part **116**

symmetrically associated therewith, preferably through gluing, welding, pressure-fitting or folding.

[0047] To form the room air channels **110** for the humid room air or for room air which is to be cooled, each plate part **116** or **118** is provided with shaped parallel groove-like depressions **124** having a semi-circular cross-section. These can join together into cylindrical pipes or flat pipes wherein, in the latter case, it would be favorable to impart a wavy cross-section to the two flat-sided pipe wall parts. To construct the cooling air channels **112**, bridges **126** are formed in the plate parts **116,118** which extend perpendicularly downward, parallel to one another and transversely with respect to the depressions **124** or to the longitudinal edge parts **120,122** thereof which are connected to one another in an air-tight fashion.

[0048] If the heat exchanger serves to temper room air, the bridge wall parts of the double-walled bridges **126** must be rigidly connected, preferably mutually, to prevent sideward distension at corresponding operating pressures.

[0049] Each plate **114** is therefore characterized by upper and lower bridges **126** lying in a common vertical plane. The depressions **124** and bridges **126** impart a sufficient rigidity to the plate parts **116,118** (made of thin plastic sheet of a thickness of preferably merely 0.20 mm to 0.40 mm) to ensure production of a media guiding body, which is self-reinforced through mutually rigidly connecting stacked plates **114** (see FIG. 9).

[0050] To form cooling air channels **112** in the plate composite shown in FIG. 11, the bridges **126** of a plate **114** engage between two bridges **126** of a plate **114** disposed below or above same, preferably such that neighboring bridges **126** contact each other (1st variant). Alternatively, the bridges **126** of two plates **114** (see dash-dotted lines) can centrally engage between those of the other plate **116**, thereby doubling the number of cooling air channels **112** and increasing the efficiency of the heat exchanger (2nd variant).

[0051] The plates **114** of the plate packet or media guiding body are each commonly held in a sealing fashion at their front ends in a holding frame **128** or **130** (preferably made from plastic) via an adhesive **132**, preferably a casting resin.

[0052] The bridges **126** of the upper and lower plates **114** are each covered by a plate **132** or **134** to form outer heat exchanger cooling air channels **112**, the front ends of which are also fixed in the holding frame **128, 130**.

[0053] The heat exchanger formed in this fashion does not thereby have a casing for forming the condensation outlet channels **110**. It can be inserted into a casing opening of an air conditioning device as a structural unit, wherein a grip **138** is provided on its front end for handling. It can also be mounted within such a device.

[0054] FIGS. 13 and 14 show an inventive method for producing the plate parts **18** from metal foil.

[0055] Groove-like depression portions **142** are formed in an aluminum sheet **140** in the longitudinal direction of the subsequent room air guiding channels **110** and gable roof-

like sections **144, 146** are shaped transverse to the longitudinal extension thereof. Towards this end, continuous groove-like depressions and gable roof-like sections are formed transverse thereto, in the same shaping direction. Finally, the sheet **140** is pushed together in the direction of extension of the groove-like depression portions **142** such that same contact one another at their front ends and the two halves of the gable roof-like sections **144, 146** substantially abut one another to form the bridges **126**.

[0056] The plate parts can be produced from a plastic sheet, e.g. polypropylene (preferably of a thickness of approximately 0.20 mm) through thermal, vacuum forming. The sheet is pre-heated and drawn into the desired shape in a tool, preferably in one single step. The above-mentioned step of pushing together can then be omitted. Fin or sword-like metal strips are inserted into the tool to form the bridges **126** shown in the figures.

[0057] In accordance with a further embodiment shown in FIG. 15, the bridge portions **150** are divided in the longitudinal direction and offset transverse to their longitudinal direction. The fin or sword-like metal strips do not cut-through the plastic sheet, rather same is effectively deep-drawn to thereby obtain a circumferential contour of the bridge portions **150** which is closed in the circumferential direction, as well as a rounded flow edge **152**.

I claim:

1. A method for using a heat exchanger, the method comprising the step of:

controlling one of a temperature and an air-conditioning in a room or compartment, wherein the heat exchanger comprises a media guiding body having two groups of crossing channels for media to be guided separately, of which a first channel group is formed as pipes and a second channel group is formed as shafts, wherein said second channel group is defined by bridges provided at a separation from one another on an outer side of said pipes and oriented transverse to pipe axes, wherein said first channel group and said bridges are commonly produced from at least one formed sheet, consisting essentially of one of a thermoplastic material and a heat-conducting metal.

2. The method of claim 1, wherein room air is guided in said first channel group and cooling air is guided in said second channel group.

3. The method of claim 1, wherein room air is guided in said second channel group and cooling air is guided in said first channel group.

4. The method of claim 1, wherein a gaseous medium is guided in said first channel group and a liquid medium is guided in said second channel group for at least one of cooling and heating the room or compartment.

5. The method of claim 1, wherein a gaseous medium is guided in said second channel group and a liquid medium is guided in said first channel group for at least one of cooling and heating the room or compartment.

* * * * *