

(No Model.)

4 Sheets—Sheet 1.

F. A. WALSH.  
SHEET METAL WORKING MACHINE.

No. 512,342.

Patented Jan. 9, 1894.

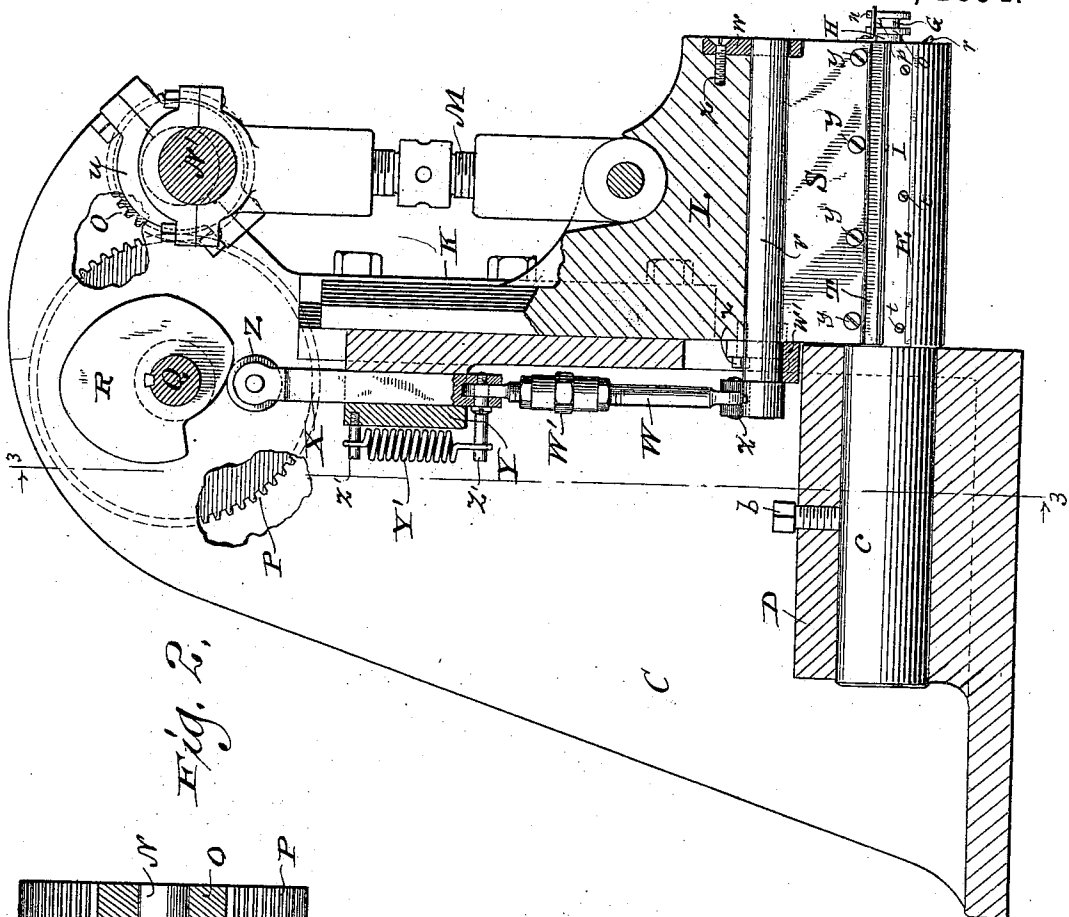

*Fig. 2.*

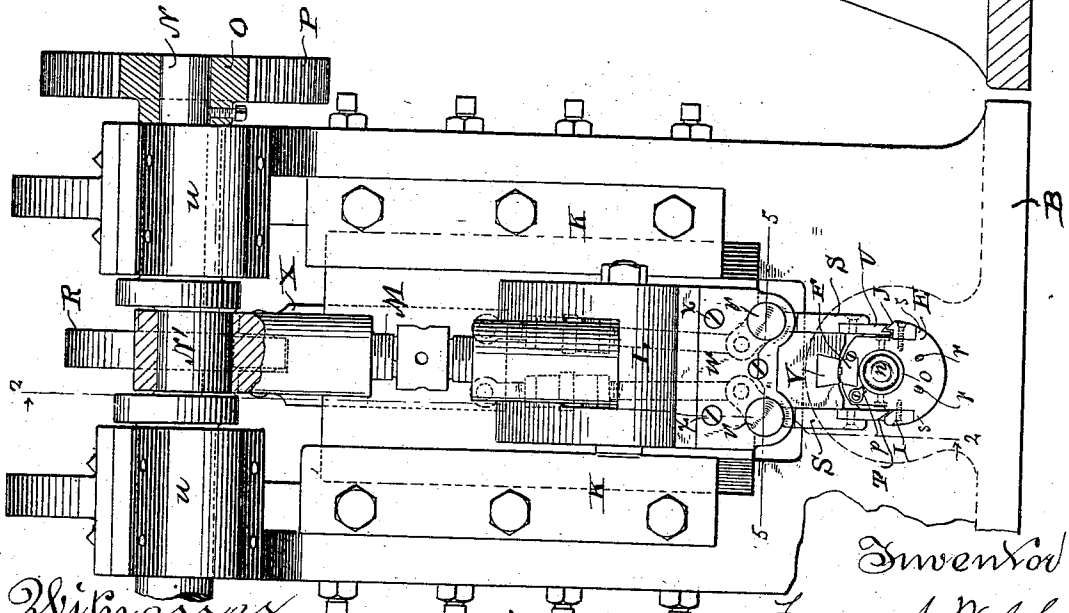

*Fig. 1.*

*Witnesses,  
Geo. W. Young,  
H. E. Cliphant*

*Invented  
Francis A. Walsh*

*By H. G. Underwood  
C. Worcester*



F. A. WALSH.  
SHEET METAL WORKING MACHINE.

No. 512,342.

Patented Jan. 9, 1894.

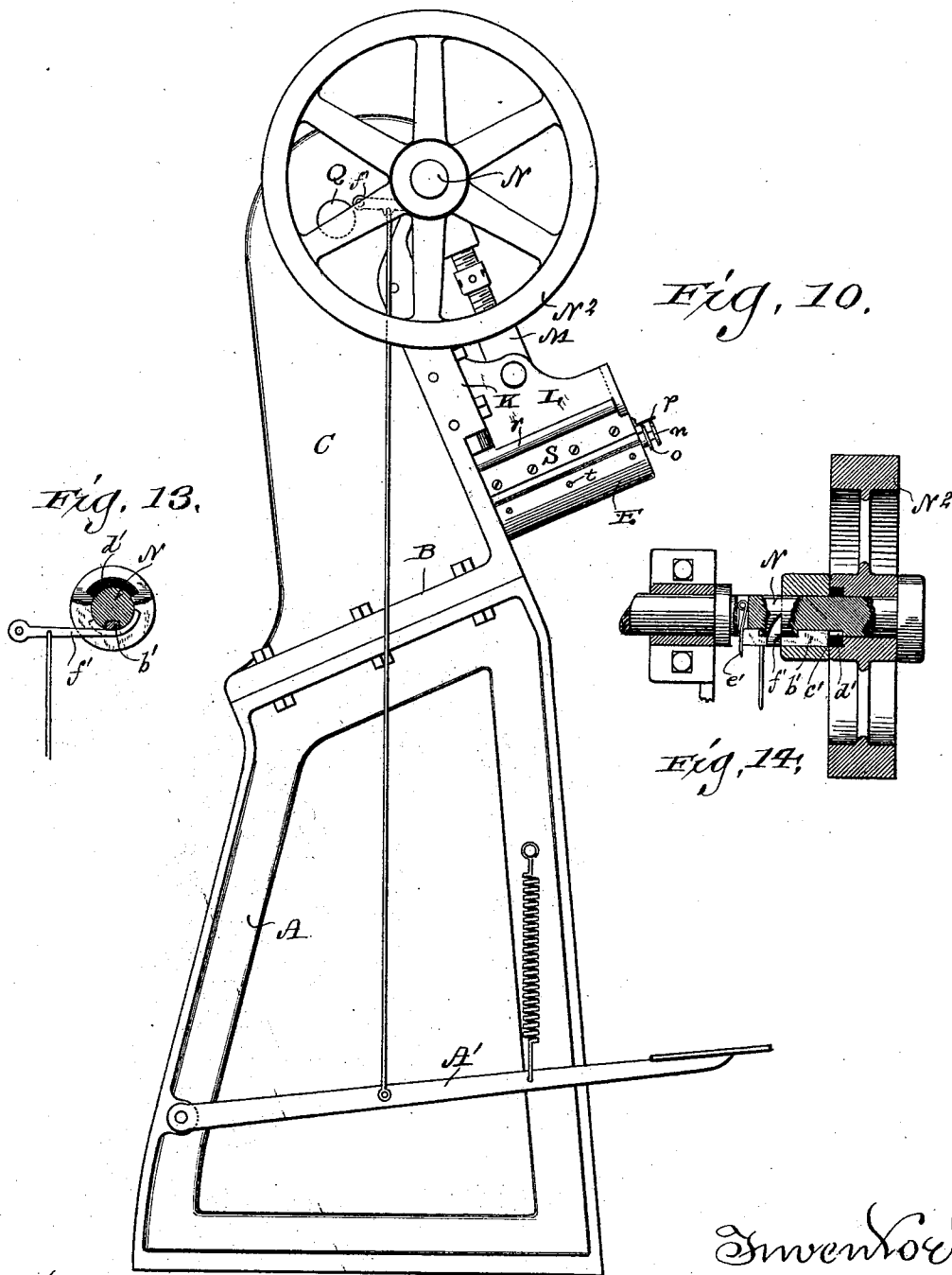

Witnesses.  
 Geo. W. Young,  
 W. E. Oliphant

Inventor  
 Francis A. Walsh  
 By H. G. Underwood  
 Attorney

F. A. WALSH.  
SHEET METAL WORKING MACHINE.

No. 512,342.

Patented Jan. 9, 1894.

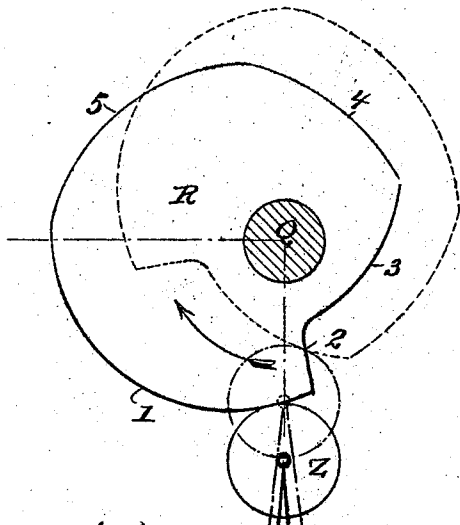

Fig. 11.

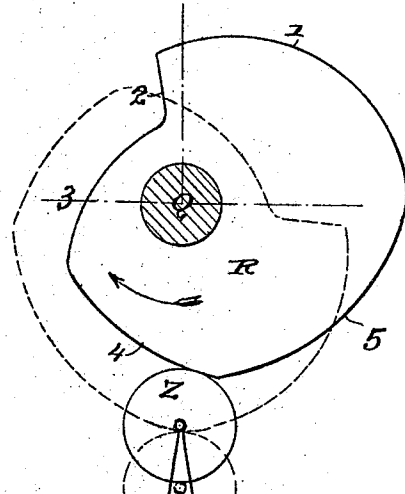
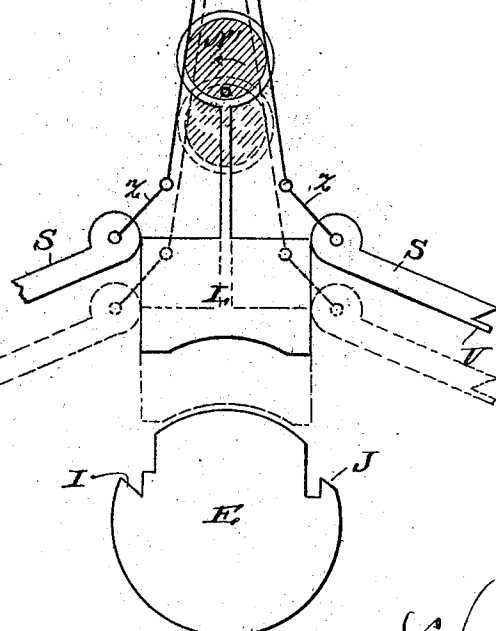
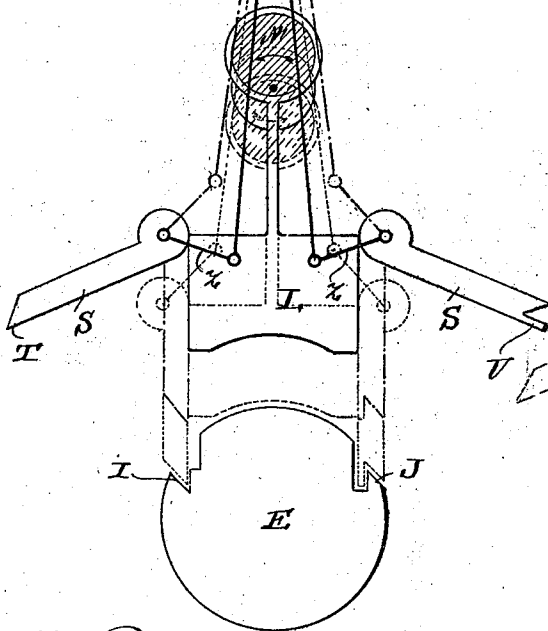

Fig. 12.



Witnesses  
Geo. W. Young  
N. E. Oliphant

Inventor  
Francis A. Walsh  
By H. G. Underwood  
Attorney

# UNITED STATES PATENT OFFICE.

FRANCIS A. WALSH, OF MILWAUKEE, WISCONSIN.

## SHEET-METAL-WORKING MACHINE.

SPECIFICATION forming part of Letters Patent No. 512,342, dated January 9, 1894.

Application filed April 25, 1893. Serial No. 471,818. (No model.)

*To all whom it may concern:*

Be it known that I, FRANCIS A. WALSH, a citizen of the United States, and a resident of Milwaukee, in the county of Milwaukee, and in the State of Wisconsin, have invented certain new and useful Improvements in Sheet-Metal-Working Machines; and I do hereby declare that the following is a full, clear, and exact description thereof.

My invention has for its object to provide a simple, economical machine for operating on sheet-metal stock, especially in the matter of folding and seaming, this machine being analogous, in some particulars, to those set forth in my Patents Nos. 445,738, 445,739, and 445,740, of February 3, 1891. Therefore the said invention consists in certain peculiarities of construction and combination of parts hereinafter described with reference to the accompanying drawings and subsequently claimed.

In the drawings: Figure 1 represents a front elevation of my machine partly in section; Fig. 2, a side elevation of the same, partly in section on line 2—2 of the preceding figure, and partly broken away; Fig. 3, a vertical transverse section taken on line 3—3 of Fig. 2; Fig. 4, a transverse section taken on line 4—4 of the succeeding figure; Fig. 5, a horizontal section taken on line 5—5 of Fig. 1; Fig. 6, a detail sectional view illustrating a gage-mechanism forming part of the machine herein set forth; Fig. 7, a detail side elevation, partly in section, also illustrating the gage-mechanism; Figs. 8 and 9, transverse sections respectively taken on lines 8—8 and 9—9 of Fig. 6; Fig. 10, a side elevation of a complete machine, embodying my improvements, and Figs. 11 and 12 diagrams illustrating the operation of said machine. Figs. 13 and 14 represent detail sectional views of one form of clutch-mechanism that may be employed as part of the aforesaid machine.

Referring by letters and numerals to the drawings A represents the base-frame of my machine, the upper portion of this frame being preferably inclined as shown in Fig. 10. Bolted or otherwise rigidly secured to the inclined portion of the base-frame is a casting comprising a bed-piece B, parallel standards C and a box D intermediate of the standards.

Detachably held in the box D, by means of a set-screw *b*, is the shank *c* of a horn E, the latter being herein shown as provided with a longitudinal bore *d* for the reception of a gage-adjusting mechanism hereinafter specified. The upper portion of the horn is shown as provided with a dove-tail groove for the reception of a detachable impact surface or anvil F that has a seam-receiving groove and is recessed from its under side to form chambers for springs controlling stop-pins *f* that normally extend through the exposed face of said device. Fitted in lateral openings in the horn, at each side of the latter, is a series of gages *g*, *h*, and the inner ends of these gages abut against adjusting devices G, H loose in the bore *d* of said horn. As herein shown I provide the sides of the horn with recesses *i* in which I arrange flat-springs *j* having ends thereof engaged by notches in the gages *g*, *h*, and operating to automatically retract said gages when the adjusting devices G, H, for the same are properly positioned.

The gage-adjusting device G is a rod that turns freely in a sleeve that constitutes the gage-adjusting device H, as is best illustrated in Fig. 6, it being apparent in the same figure that the rod is for use in connection with the gages *g* and that the sleeve co-operates with the gages *h*, each set of said gages being adjustable independent of the other set. In order to provide for the lateral adjustment of the gages, the rod G and sleeves H are partially circular in cross-section and partially elliptical in like section, the elliptical portions of one being lettered *k* and those of the other *m*, and it is these elliptical portions of said rod and sleeve that actuate said gages against the resistance of the springs *j* above specified. The rod G is shown as having its outer end provided with a head *n* scaled upon the rim, and the outer end of the sleeve H has a similar head *o*, both of these heads being opposed by an indicator-finger *p* held on the adjacent end of the horn E, whereby a desired adjustment of certain of the gages in the series, incidental to a partial rotation of said rod and sleeve, may be accurately determined.

In the present organization of the machine, I show four gages in each series, and the rela-

tive arrangement of the elliptical portions of the adjusting devices are such that either the two extreme gages or those intermediate of the same in both series are actuated against the resistance of their retracting springs *j*, the amount of adjustment determining the depth of folds at the edges of metal sheets, these folds being made in the manner hereinafter set forth. The extreme gages in each series are for long stock and the intermediate ones for short stock. In order to push out either extreme or intermediate gages in both series a sliding movement in the proper direction is imparted to the rod G and sleeve H, whereby one or the other of the gages *g* and *h* in each series will have their inner ends opposed by the relative elliptical portion of said rod and sleeve, and the remaining gages being cleared by other elliptical portions of the said rod and sleeve, will be retracted by their springs *j* against the circular portions of the adjusting devices to thereby bring their outer ends flush with the horn E in which they have their movement. Inasmuch as the rod G and sleeve H may be rotated independent of each other, the gages controlled by one may have a greater or less extension from the horn than those controlled by the other to thereby come upon a line oblique to said horn, such an adjustment being sometimes desirable for certain varieties of work.

In order to maintain the rod G and sleeve H in their adjusted positions, I employ any suitable means, and, as suitable to the purpose, I may employ plugs *q* movable in inclined openings in the outer end of the horn E and held in frictional contact against said rod and sleeve by set-screws *r* having their bearings in the horn-openings. In such a construction and arrangement of parts it will be necessary to cut out a portion of the sleeve H in order to obtain clearance for the plug *q* that is operated by one of the set screws *r* to lock the rod G, as clearly illustrated in Fig. 7, and the duplicate set-screw operates the plug (not shown) that bears against the sleeve H, both screws being shown in Fig. 1.

As herein shown, the horn E has its sides provided with horizontal ledges *s* that serve as seats for vertically disposed longitudinal die-blocks I, J, held in place by screws *t* that pass through the same and enter said horn, as clearly illustrated in Fig. 8. The die-blocks I, J, are positioned below the gages *g*, *h* above specified, and the working contours of these blocks are practically the same as dies set forth in my former patents, above named. In other words, the working contour of block I is a longitudinal groove having one face normally at a right angle to a metal sheet opposed thereto and another face forming an acute angle with the first; the working contour of the block J being a longitudinal edge having faces that form an acute angle with each other reverse to similar faces in the groove of the former block.

The standards C above named are provided

with detachable and laterally adjustable guides K (common in the art) for a plunger L connected, by an adjustable hanger M, to a crank-portion N' of a shaft N that has its bearings *u* in said standards, and is provided with a drive-pulley N<sup>2</sup>, the latter being shown in Fig. 10. Fast on the crank-shaft is a pinion O and this pinion meshes with a spur-wheel P rigidly connected to another shaft Q that also has its bearings in the standards C and carries a cam R for the purpose hereinafter specified. The plunger L, as herein shown, has a lower reduced portion provided with bearing grooves for the rounded heads *v* of wings S held in place by means of bearing plates *w w'* secured to the front and rear of said plunger by screws *x* or other suitable devices.

The wings S have their lower edges in the form of dies and the latter are preferably detachable blocks T, U, positioned flush with the inner sides of said wings and rigidly secured to the latter by screws *y* or other suitable means. The working contour of the latter die-blocks are similar in detail to the ones I, J, above specified and engage with the same at predetermined intervals incidental to a downward movement of the plunger L and the operation of certain mechanism hereinafter set forth. In the operation of the machine, the movable die T comes in and out of engagement with the stationary die I, and likewise the one U operates in conjunction with the one J to form reverse folds at the edges of interposed sheets of metal.

As a matter of preference, an impact surface or hammer V is dovetailed into the lower horizontal face of the plunger L to oppose the anvil F in the horn E above specified. The rear ends of the wing-heads *v* are connected by cranks *z* with the lower ends of links W having swivel-sections W', by which latter said links are made adjustable as to length. The upper ends of the links W are connected to a block X that loosely engages a guide-box Y intermediate of the standards C hereinbefore set forth, and journaled in the block is an anti-friction roller Z that opposes the cam R also specified in the foregoing.

In order to keep the roller Z in contact with the cam at all times, I employ a spiral-spring Y' having its extremities joined to the block X and its guide-box Y by pins *z'* or other suitable means, as best illustrated in Fig. 2, but this is only one of various constructions for accomplishing the same result, and therefore I do not wish to be understood as restricting myself thereto in the organization of the machine.

The drive-pulley N<sup>2</sup> of the machine is normally loose on the shaft N, and any suitable clutch-mechanism, such for instance as the one shown in my prior patent, No. 445,738, may be employed to rigidly unite said pulley and shaft when it is desirable to operate said machine.

In Fig. 10, I show a clutch-actuating lever pivoted to one of the standards C and linked to a spring-controlled treadle A' connected to the base frame of the machine. The clutch-mechanism herein shown is substantially the same as that set forth in my Patent No. 445,738, of February 3, 1891, and comprises a sliding key *b'* movable in the groove *c'* in the shaft N to come in and out of engagement with a recess *d'* in the hub of the pulley N<sup>2</sup>, the engagement being automatically effected by means of a spring *e'* arranged in a transverse slot in said shaft, while the disengagement is brought about by the entrance of the curved and wedge shaped free end of the lever *f'* into a transverse groove in the key *b'*, whereby the power of spring *e'* is overcome and said key withdrawn from the pulley-hub. The free end of the clutch-lever is curved to conform to the contour of the adjacent shaft and its disengagement with the spring-controlled key is incidental to a depression of the foot-treadle above specified.

The operation of the machine will be best understood by reference to the diagrams Figs. 11 and 12, and in this connection it is proper to state that the gearing between the shafts N, Q, is of such proportion that the first of these shafts makes two revolutions to one of the other. As shown by full lines in the diagrams, the plunger L is at its greatest possible elevation incidental to the throw of the crank N' of the shaft N, and the block X having been run down against the power of the spring Y' remains in this position incidental to a pressure of the face *l* of cam R against the anti-friction roller Z, thus acting to hold the die-wings S outward from said plunger, the previous descent of said block having caused a rock of said wings in their bearings because of the crank-and-link connections with the aforesaid block. The cam face *l* having passed the anti-friction roller Z, the contraction of the spring Y' will cause a return of the block X to its normal position, owing to a drop 2 in the cam, and incidental to this return movement of said block, the aforesaid die-wings will be swung in against the plunger L as shown in dotted lines. At the same time the plunger is on its descent and the face 3 of the cam is of such contour that no pressure is exerted thereby during the time said plunger moves down. Owing to the proportions of the gearing between the shafts N, Q, the first of the same has now made one-half of a revolution to a quarter revolution of the other, and there is an engagement of the dies T, I, and U, J, to form folds in interposed metal supported on the horn dies against the previously adjusted gages. The die-wings are held down against the plunger long enough during the ascent of the same to have the upper dies clear the lower ones and at this time the face 4 of the cam begins to exert pressure and actuate the block X in a downward direction and thereby cause a full outward rock of said die-wings

by the time the shaft N has completed a revolution and is stopped by the automatic withdrawal of the clutch-key *b'* from the hub of the driving-pulley. The folds of the metal having been engaged and the seam thus formed laid upon the anvil F, the clutch-lever is retracted to permit another start of the machine, and incidental to this start, the descent of the plunger impacts the hammer V against said seam to close the latter, the succeeding faces 5 and 1 of the cam being of such contour as to prevent an inward swing of the die-wings while the seam-closing operation takes place, the cam-shaft making one-half of a revolution to the necessary full revolution of the crank-shaft to which said plunger is connected.

While I have shown the machine organized for the purpose of making seam-folds and subsequently closing a seam formed by an engagement of two such folds, said machine may be organized for a variety of operations by a mere substitution of suitable dies for those shown. It is also possible to substitute horns of various contour for the one shown, according to the work to be accomplished. It is also to be understood that the movable dies may be brought in and out of working position by other than a rocking movement of themselves or parts to which they may be detachably connected.

Having thus described my invention, what I claim as new, and desire to secure by Letters Patent, is—

1. In a sheet-metal working machine, the combination of a suitable die-support provided with lateral openings adjacent to the dies thereon, a series of gages in said openings and suitable means for positively adjusting the gages, substantially as set forth.

2. In a sheet-metal working machine, the combination of a suitable die-support provided with lateral openings adjacent to the dies thereon, a series of gages in said openings, and suitable means for positively adjusting certain of the gages independent of the others in the series substantially as set forth.

3. In a sheet-metal working machine, the combination of a suitable die-support provided with lateral openings adjacent to the dies thereon, a series of gages in said openings, suitable means for positively adjusting the gages, and retracting springs connected to said gages, substantially as set forth.

4. In a sheet-metal working machine, the combination of a suitable die-support provided with lateral openings adjacent to the dies thereon, a series of gages in said openings, an adjusting mechanism for the gages, and suitable means for locking the adjusting mechanism, substantially as set forth.

5. In a sheet-metal working machine, the combination of a die-support having a longitudinal bore and provided with lateral openings communicating with the bore, a series of gages in said openings, a rotative rod and sleeve of differential length engaging each

other and said bore, and elliptical projections on the rod and sleeve, substantially as set forth.

6. In a sheet-metal working machine, the combination of a die-support having a longitudinal bore and provided with lateral openings communicating with the bore, a series of gages in said openings, a rotative rod and sleeve of differential length engaging each other and said bore, elliptical projections on the rod and sleeve, and suitable means for locking said rod and sleeve in their adjusted positions, substantially as set forth.

7. In a sheet-metal working machine, the combination of a die-support having a longitudinal bore and provided with lateral openings communicating with the bore, a series of gages in said openings, a rotative rod and sleeve of differential length engaging each other and said bore, elliptical projections on the rod and sleeve, and screw-controlled locking-plugs for said rod and sleeve substantially as set forth.

8. In a sheet-metal working machine, the combination of a die-support having a longitudinal bore and provided with lateral openings communicating with the bore, a series of gages in the openings, springs connecting the die-support and gages, a rotative rod and sleeve of differential length engaging each other and said bore, and elliptical projections on said rod and sleeve, substantially as set forth.

9. In a sheet-metal working machine, the combination of dies, adjustable gages adjacent to the dies, and a scale and indicator mechanism for accurately determining the adjustment of the gages substantially as set forth.

10. In a sheet-metal working machine, the combination of a die-support having a longitudinal bore and provided with lateral openings communicating with the bore, a series of gages in said openings, a rotative rod and sleeve of differential length engaging each other and said bore, elliptical projections on the rod and sleeve, scale-heads on the outer ends of said rod and sleeve and a stationary index finger for the scale-heads, substantially as set forth.

11. In a sheet-metal working machine, the combination of a stationary support, dies detachably secured thereto, a plunger provided with detachable dies corresponding to those on the support, and suitable means for bringing one die of each pair out of the way of the other, substantially as set forth.

12. In a sheet-metal working machine, the combination of a stationary support provided with dies, a plunger provided with dies corresponding with those on the support, and suitable means for bringing one die of each pair out of the way of the other at each alternate descent of the plunger without rotary movement of the latter device, substantially as set forth.

13. In a sheet-metal working machine, the

combination of a stationary support provided with dies and an impact surface intermediate of these dies, a plunger also provided with dies corresponding to those on the support, and an impact surface opposed to the one aforesaid; and suitable means for bringing one die of each pair out of the way of the other without rotary movement of the latter device, substantially as set forth.

14. In a sheet-metal working machine, the combination of a stationary support provided with dies, a plunger also provided with dies corresponding to those on the support, and suitable means for bringing the plunger-dies in and out of working position coincident with alternate descents of the plunger without rotary movement of the latter device substantially as set forth.

15. In a sheet-metal working machine, the combination of a stationary support provided with dies, a plunger, wings having bearings in the plunger and terminated at their free ends in dies corresponding to those on the support, a crank-mechanism connected to the die-wings, and suitable means for actuating the crank-mechanism at predetermined intervals, substantially as set forth.

16. In a sheet metal working machine, the combination of a stationary support provided with dies, a plunger, wings having bearings in the plunger and terminated at their free ends in dies corresponding to those on the support, a spring controlled crank-mechanism connected to the die-wings, and an operating cam for the crank-mechanism, substantially as set forth.

17. In a sheet-metal working machine, the combination of a bed-piece and standards, a horn connected to the bed-piece but inclined therefrom, a plunger working between the standards, metal working devices having loose connection with the plunger, and suitable means for bringing these metal working devices in and out of working position at each alternate reciprocation of said plunger, substantially as set forth.

18. In a sheet-metal working machine, the combination of a grooved horn, an impact receiving device arranged in the horn-groove and recessed from its under side to form chambers, springs arranged in these chambers, and stop-pins that rest upon the springs and normally extend beyond the exposed face of said impact receiving device, substantially as set forth.

19. In a sheet-metal working machine, the combination of a reciprocative plunger, a metal working device dependent on the plunger for its operation, and suitable means for bringing this device in and out of working position during each alternate reciprocation of said plunger, without additional movement of the latter part, substantially as set forth.

20. In a sheet-metal working machine, the combination of a reciprocative plunger, a metal working device dependent on the plunger for its operation, suitable means for

bringing this device in and out of working position during each alternate reciprocation of said plunger, and an automatic stop for the aforesaid plunger at the completion of each reciprocation thereof, substantially as set forth.

21. In a sheet-metal working machine, the combination of a pair of shafts united by gearing so proportioned that one shaft has two revolutions to one of the other, a plunger reciprocated by the shaft having the greater speed, a metal working device dependent on the plunger for its operation, and a timed mechanism connecting the slow shaft and metal working device, this mechanism being such that said device is brought in and out of working position at each alternate reciprocation of said plunger without additional movement of the latter part, substantially as set forth.

22. In a sheet-metal working machine, the combination of a pair of shafts united by

gearing so proportioned that one shaft has two revolutions to one of the other, a plunger reciprocated by the shaft having the greater speed, a metal working device dependent on the plunger for its operation, a timed mechanism connecting the slow shaft and the metal working device, this mechanism being such that said device is brought in and out of working position at each alternate reciprocation of said plunger; and an automatic stop for the plunger-controlling shaft at each revolution thereof, substantially as set forth.

In testimony that I claim the foregoing I have hereunto set my hand, at Milwaukee, in the county of Milwaukee and State of Wisconsin, in the presence of two witnesses.

FRANCIS A. WALSH.

Witnesses:

H. G. UNDERWOOD,  
N. E. OLIPHANT.