



(19) **United States**

(12) **Patent Application Publication**  
**Yoshioka et al.**

(10) **Pub. No.: US 2014/0174703 A1**

(43) **Pub. Date: Jun. 26, 2014**

(54) **HEAT EXCHANGER**

(76) Inventors: **Shun Yoshioka**, Sakai-shi (JP); **Ryuhei Kaji**, Sakai-shi (JP); **Yoshikazu Shiraishi**, Sakai-shi (JP); **Akihiro Fujiwara**, Sakai-shi (JP); **Takayuki Hyoudou**, Sakai-shi (JP)

(21) Appl. No.: **14/234,563**

(22) PCT Filed: **Jul. 19, 2012**

(86) PCT No.: **PCT/JP2012/068296**

§ 371 (c)(1),  
(2), (4) Date: **Jan. 23, 2014**

(30) **Foreign Application Priority Data**

Jul. 28, 2011 (JP) ..... 2011-165034

**Publication Classification**

(51) **Int. Cl.**  
**F28F 1/02** (2006.01)

(52) **U.S. Cl.**  
CPC ..... **F28F 1/022** (2013.01)  
USPC ..... **165/173**

(57) **ABSTRACT**

A heat exchanger includes a header, a first flat porous tube, and a second flat porous tube. The header has first and second primary channels, with first and second refrigerants flowing through the first and second primary channels. The first flat porous tube has a plurality of first refrigerant-channel holes through which the first refrigerant flows. The second flat porous tube has a plurality of second refrigerant-channel holes through which the second refrigerant flows. The header has sub-channel-forming member that forms a first sub-channel and a second sub-channel. The first sub-channel allows the first primary channel to be communicated with the first refrigerant-channel holes. The second sub-channel allows the second primary channel to be communicated with the second refrigerant-channel holes. The first flat porous tube and the second flat porous tube are in close contact to allow heat exchange between the first refrigerant and the second refrigerant.

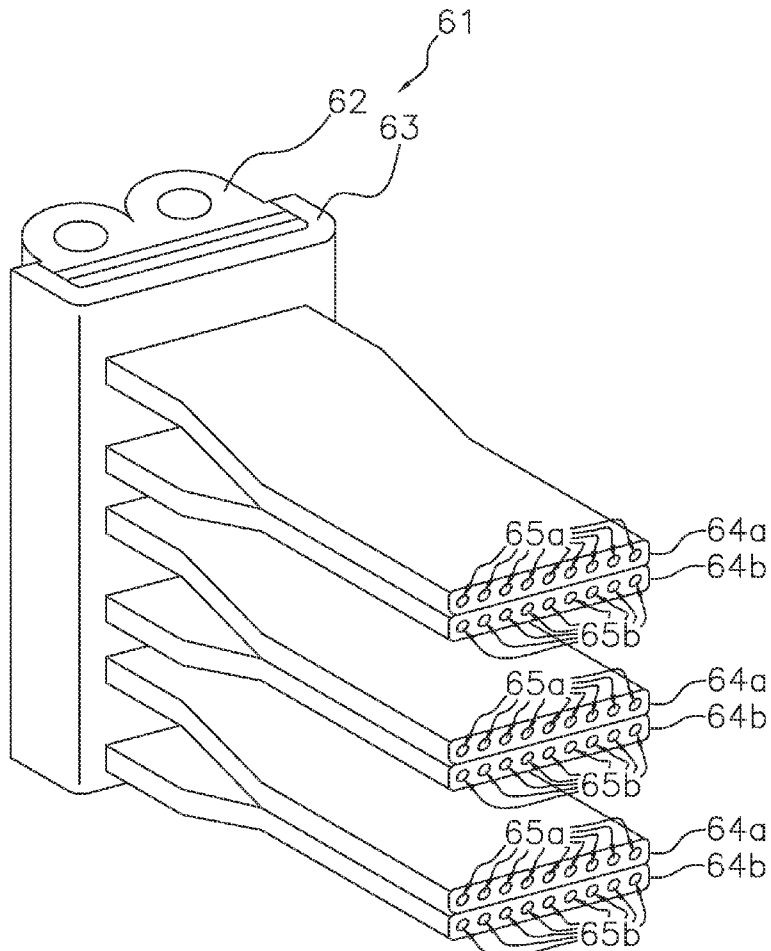

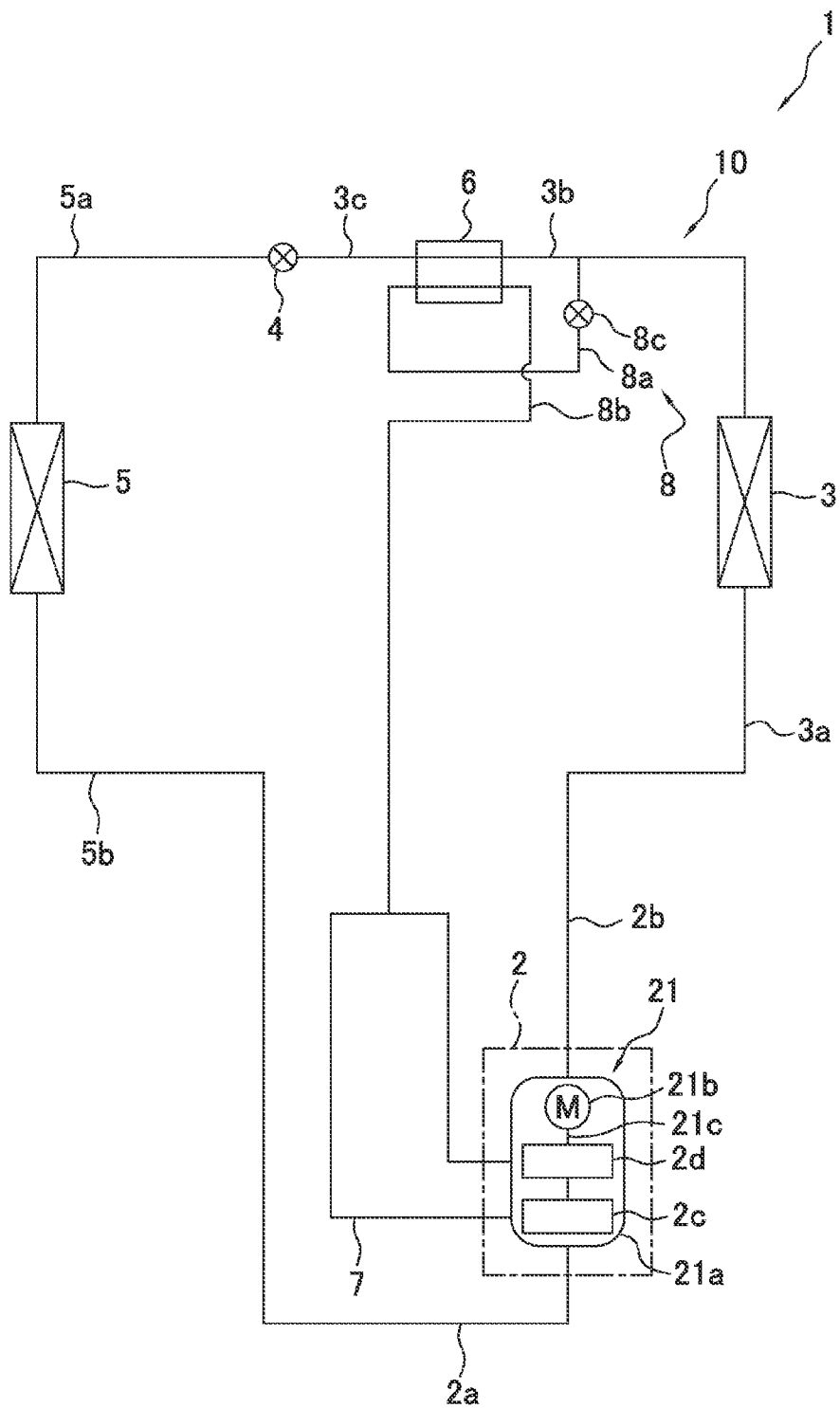

FIG. 1



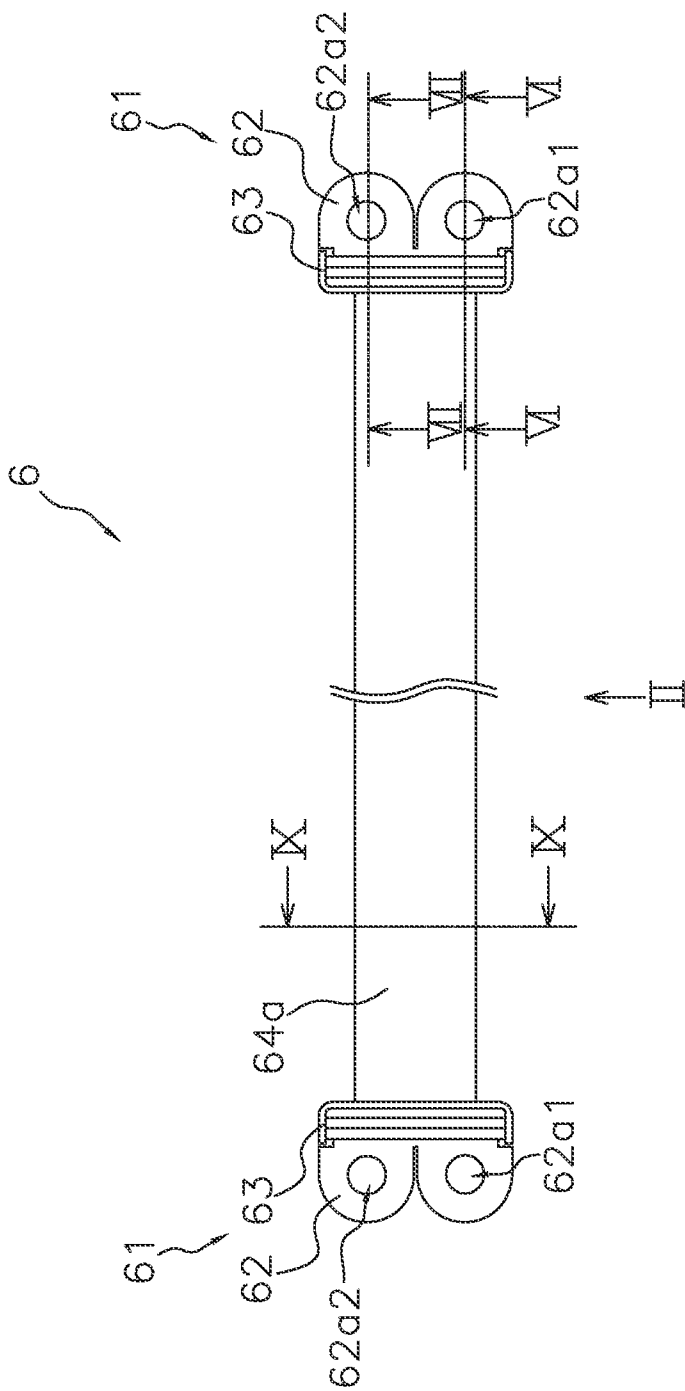

FIG. 3

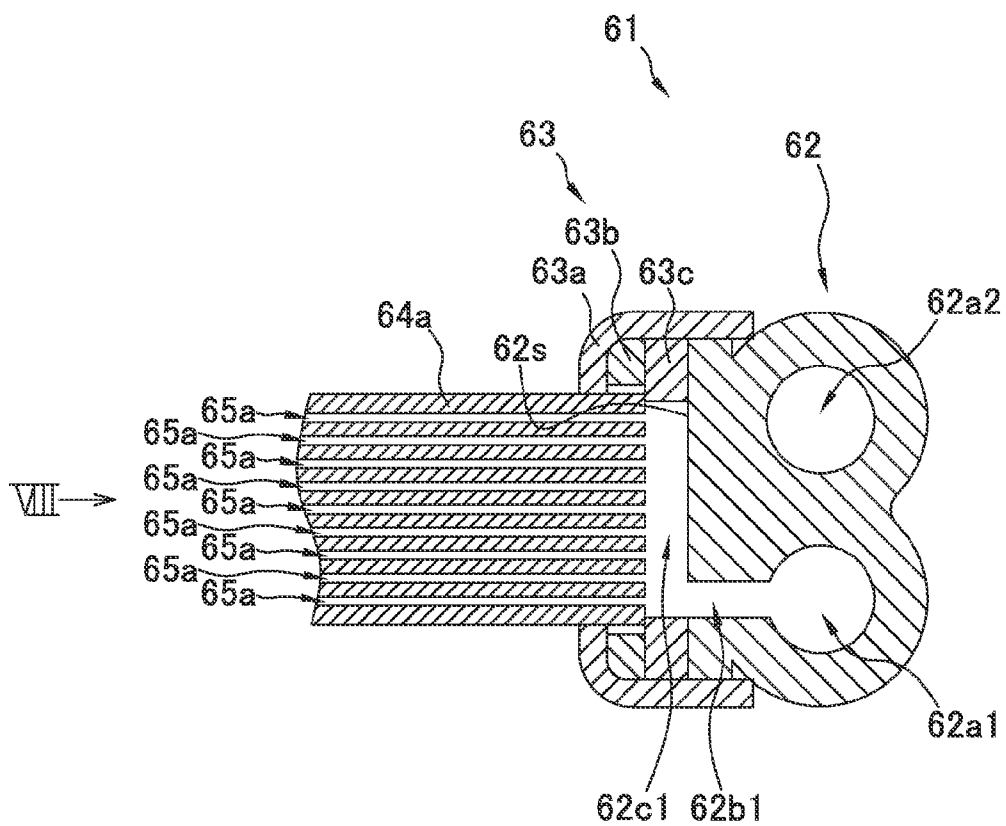

FIG. 4

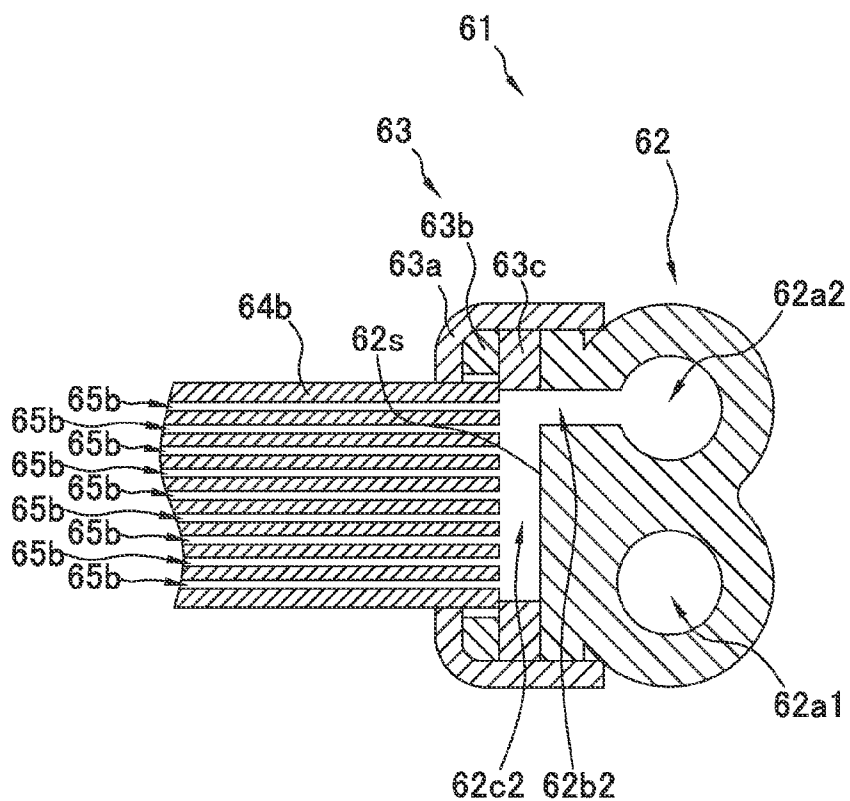

FIG. 5

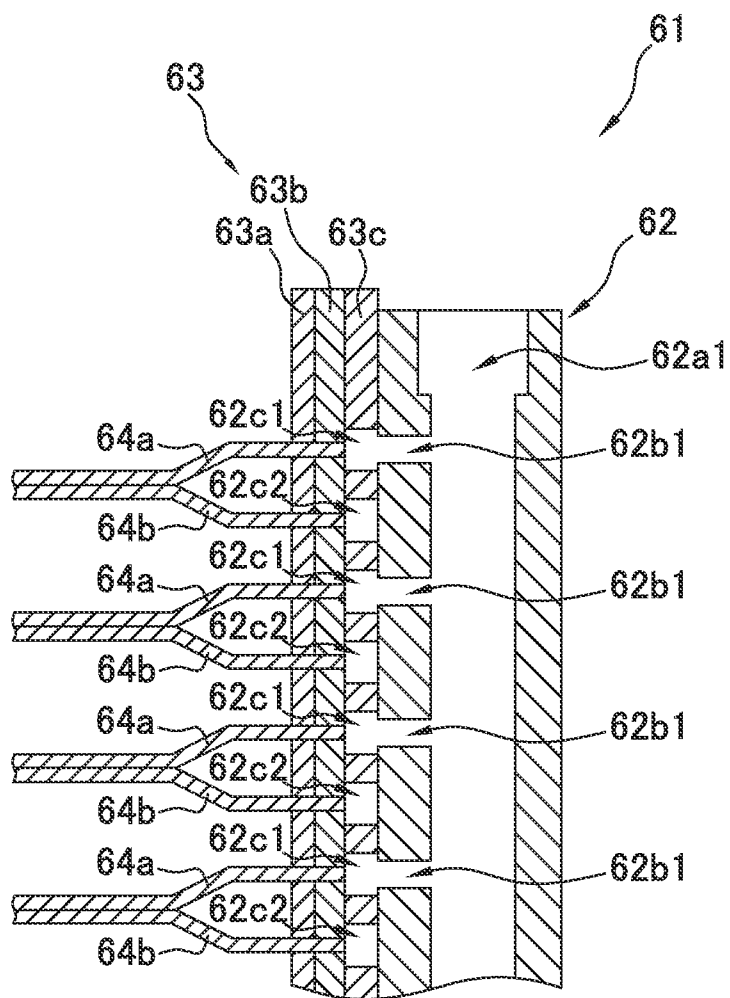

FIG. 6

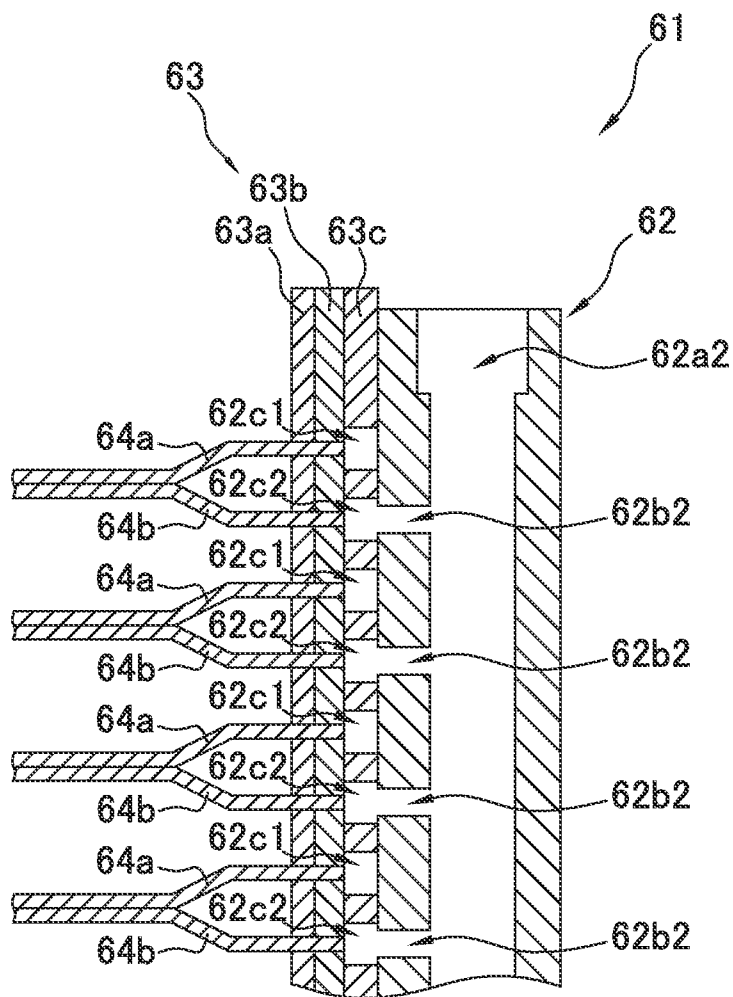

FIG. 7

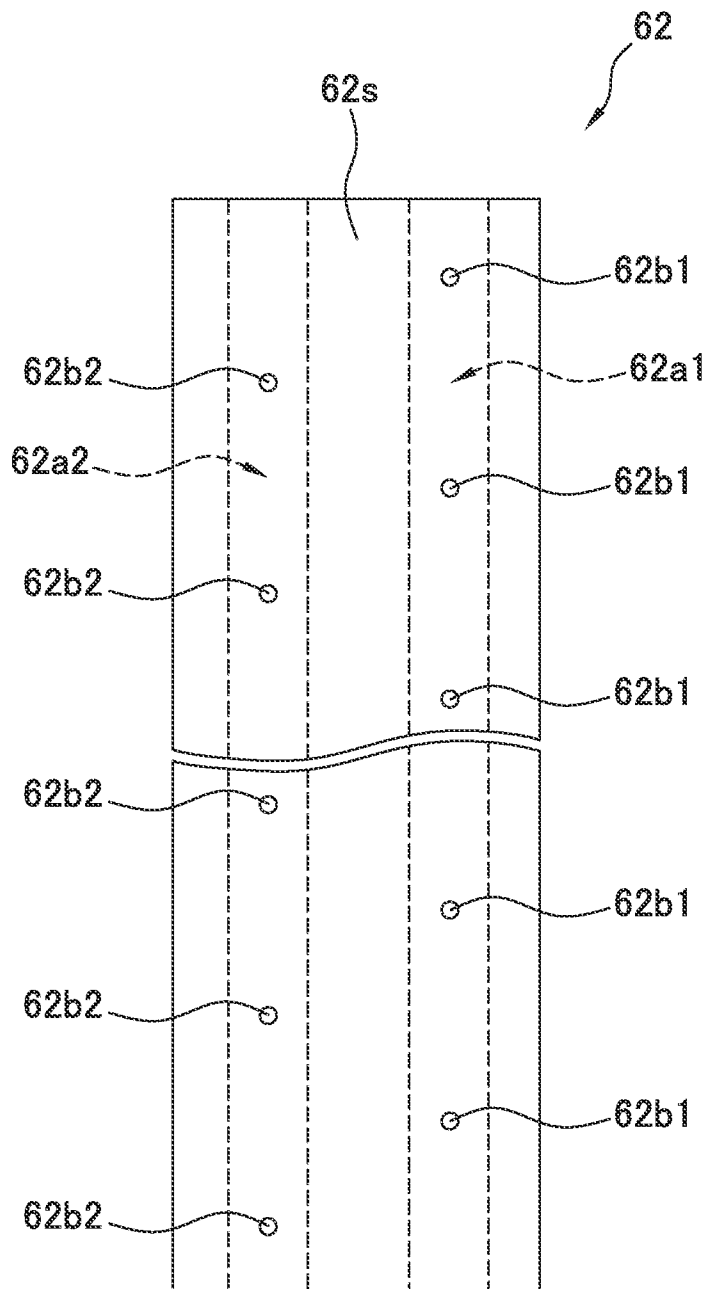

FIG. 8

FIG. 9

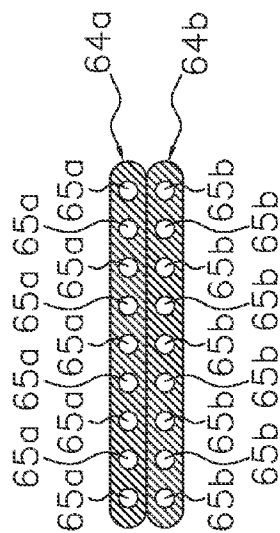

FIG. 10

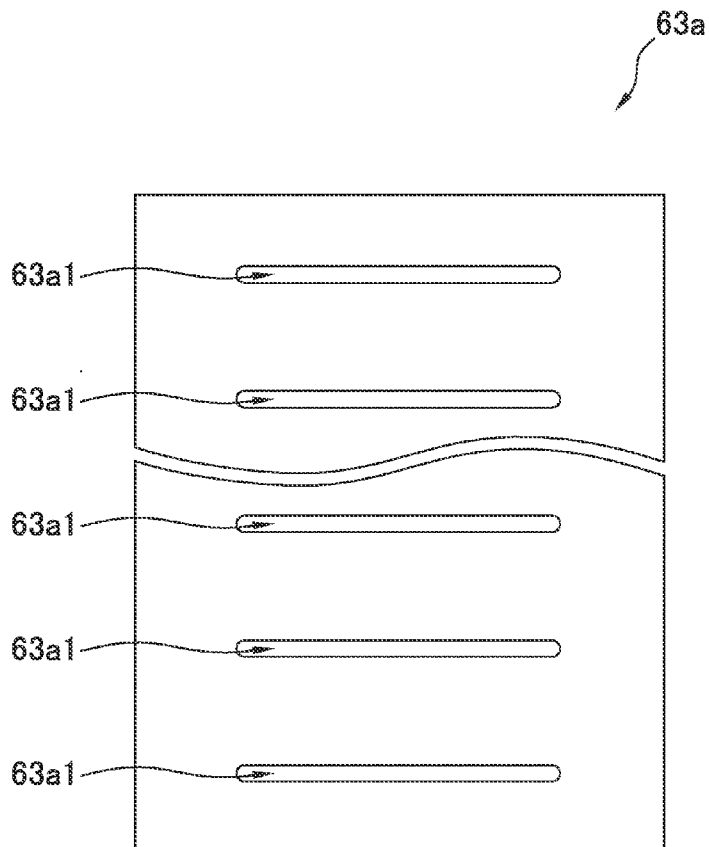

FIG. 11

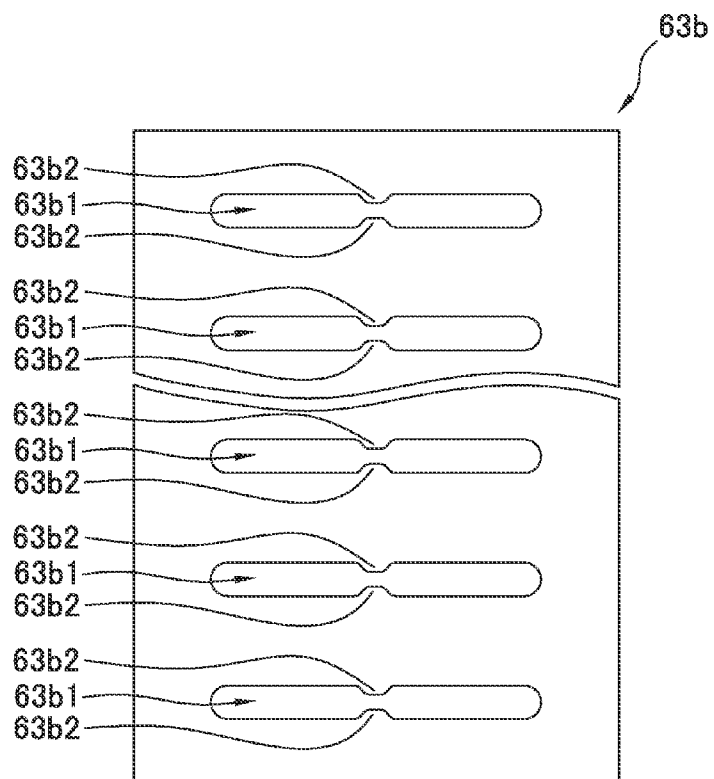
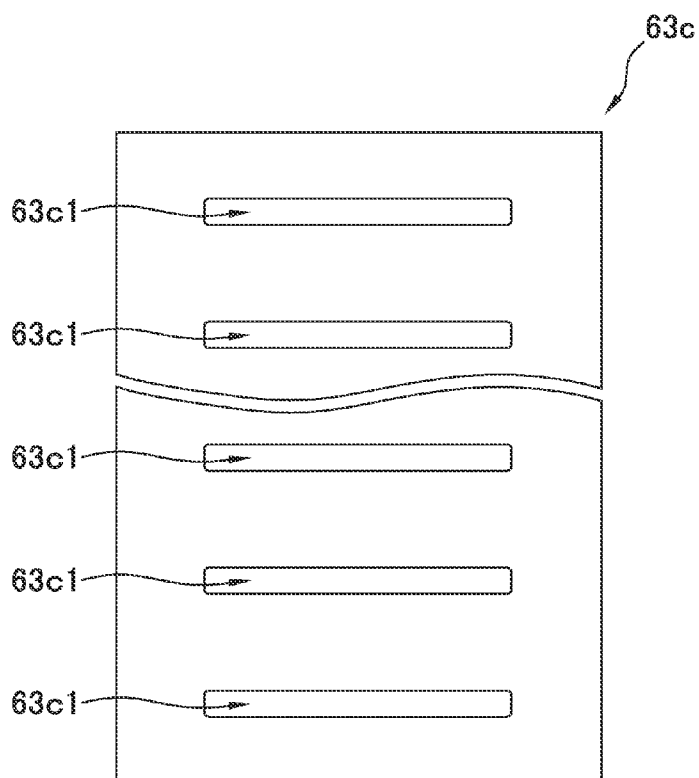

FIG. 12



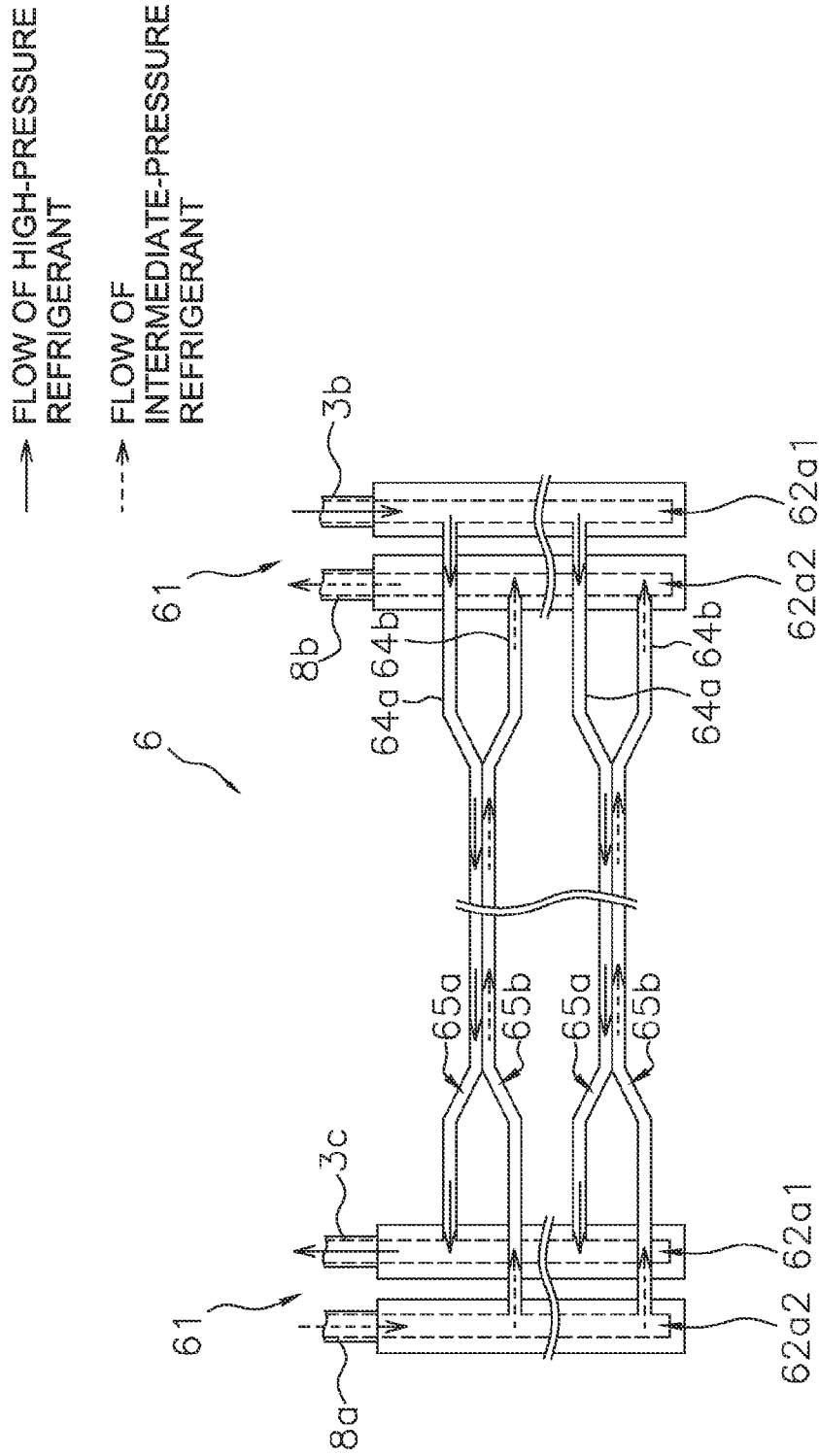

FIG. 13

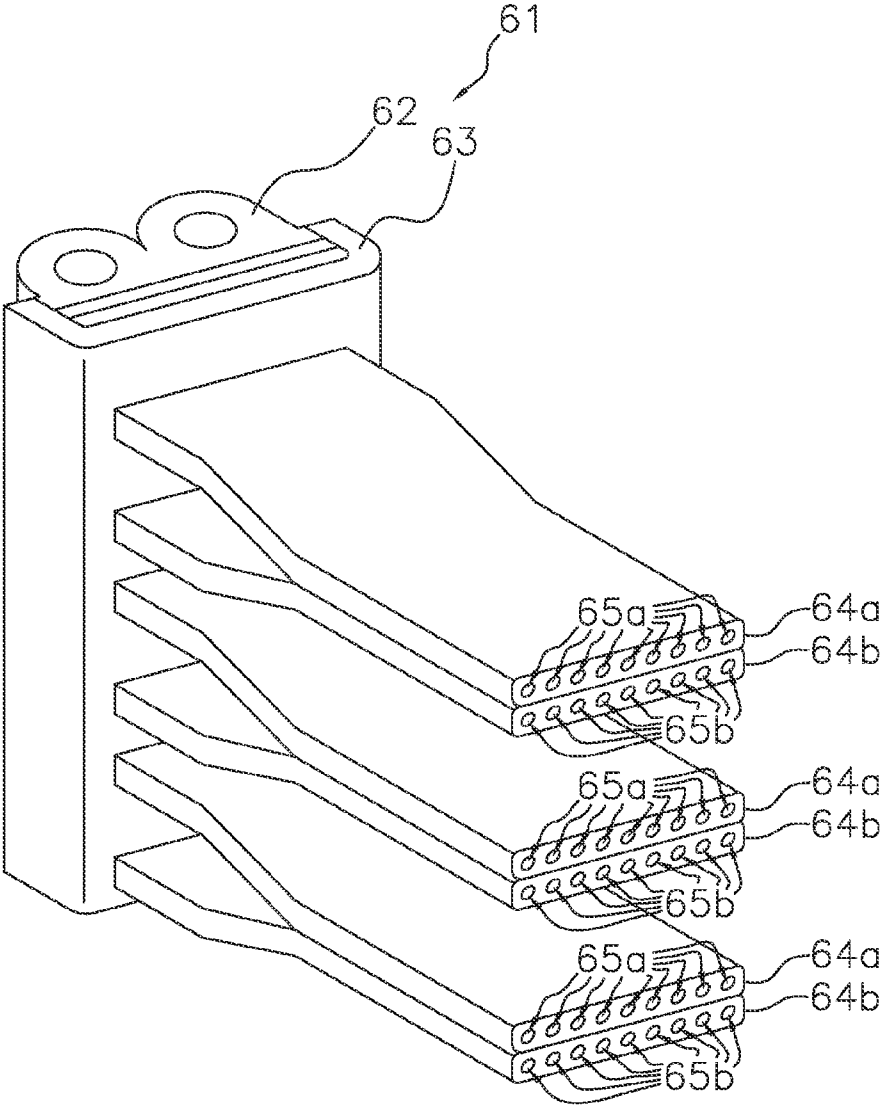
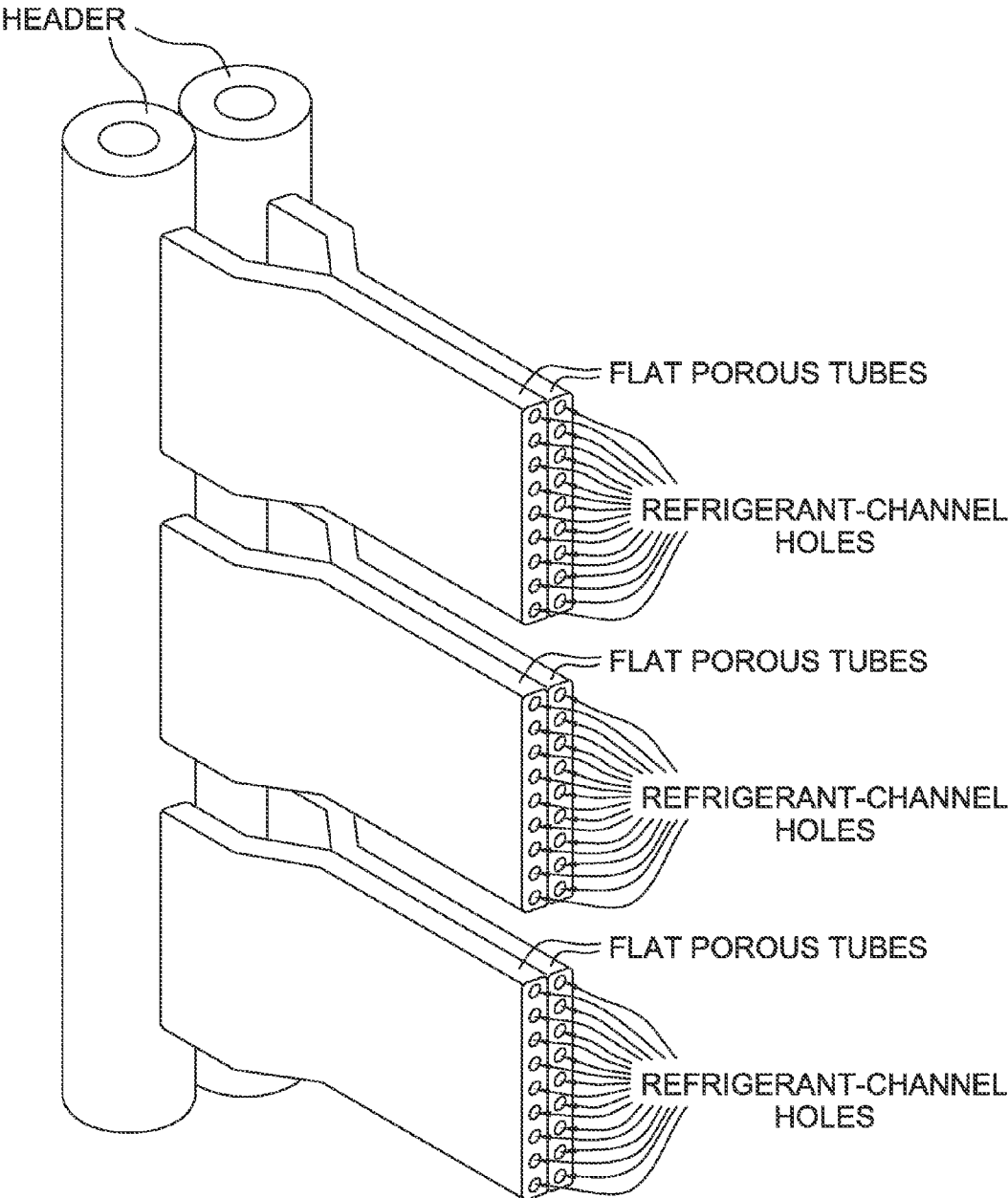

FIG. 14



(PRIOR ART)  
FIG. 15

**HEAT EXCHANGER**

## TECHNICAL FIELD

[0001] The present invention relates to a heat exchanger.

## BACKGROUND ART

[0002] Heat exchangers that use flat porous tubes to allow heat exchange between a refrigerant and a refrigerant are conventionally used in refrigeration cycles, as disclosed in Patent Document 1 (Japanese Laid-Open Patent Application No. 2007-163004). Two flat porous tubes, through which flow two respective types of refrigerant that are subjected to heat exchange, are bonded together in these heat exchangers. The flat porous tubes in these heat exchangers are linked to a header so that the alignment direction of refrigerant flow-channel holes of the flat porous tubes proceeds along a longitudinal direction of the header. The header must therefore be lengthened in cases where a plurality of the flat porous tubes are linked to the header, and the device is not readily made more compact.

## SUMMARY OF THE INVENTION

## Problems to be Solved by the Invention

[0003] It is an object of the present invention to provide a compact heat exchanger.

## Means for Solving the Problems

[0004] A heat exchanger according to a first aspect of the present invention comprises a header, a first flat tube, and a second flat tube. The header has a first primary channel and a second primary channel, a first refrigerant flowing through the first primary channel, and a second refrigerant flowing through the second primary channel. The first flat tube is linked to the header. The first flat tube is a flat porous tube that has a plurality of first refrigerant-channel holes through which the first refrigerant flows. The second flat tube is linked to the header. The second flat tube is a flat porous tube that has a plurality of second refrigerant-channel holes through which the second refrigerant flows. The header has a sub-channel-forming member. The sub-channel-forming member forms a first sub-channel and a second sub-channel. The first sub-channel allows the first primary channel to be communicated with the first refrigerant-channel holes. The second sub-channel allows the second primary channel to be communicated with the second refrigerant-channel holes. The first flat tube and the second flat tube are in close contact. In the first flat tube and the second flat tube, heat is exchanged between the first refrigerant flowing through the first refrigerant-channel holes and the second refrigerant flowing through the second refrigerant-channel holes.

[0005] In the heat exchanger according to the first aspect, the first primary channel of the header is communicated with the plurality of the first refrigerant-channel holes of the first flat tube via the first sub-channel, and the second primary channel of the header is communicated with the plurality of the second refrigerant-channel holes of the second flat tube via the second sub-channel. The first flat tube is flat along the alignment direction of the first refrigerant-channel holes. The first primary channel is formed along a longitudinal direction of the header. In cases where the first refrigerant-channel holes are directly communicated with the first primary channel, the first flat tube must be linked to the header so that the

flatness direction of the first flat tube proceeds along the longitudinal direction of the header. The header must therefore be long in cases where a plurality of the first flat tubes are linked to the header, and therefore the heat exchanger is not readily made more compact. Meanwhile, in the heat exchanger according to the first aspect, the refrigerant-channel holes are communicated with the first primary channel via, the first sub-channel, whereby the first flat tube need not be linked to the header so that the flatness direction of the first flat tube proceeds along the longitudinal direction of the header. The case is the same for the second flat tube. Therefore, the header does not need to be lengthened, and the heat exchanger according to the first aspect can be made more compact.

[0006] A heat exchanger according to a second aspect of the present invention is the heat exchanger according to the first aspect, wherein the first flat tube and the second flat tube are linked to the header so that a cross-sectional longitudinal direction intersects a longitudinal direction of the header, the cross-sectional longitudinal direction being alignment directions of the first refrigerant-channel holes and the second refrigerant-channel holes.

[0007] A heat exchanger according to a third aspect of the present invention is the heat exchanger according to the second aspect, wherein the first flat tube and the second flat tube are linked to the header so that the cross-sectional longitudinal direction is perpendicular to the longitudinal direction of the header.

[0008] In the heat exchanger according to the third aspect, the first flat tube is linked to the header so that the flatness direction of the first flat tube is perpendicular to the longitudinal direction of the header. The case is the same for the second flat tube. The heat exchanger according to the third aspect can therefore be efficiently made more compact.

[0009] A heat exchanger according to a fourth aspect of the present invention is the heat exchanger according to any of the first through third aspects, wherein the sub-channel-forming member comprises a tube-adhering member adhered to end parts of the first flat tube and the second flat tube and immobilized on the header.

[0010] In the heat exchanger according to the fourth aspect, a member for linking the first flat tube to the header and a member for linking the second flat tube to the header can be integrated. The number of components can therefore be minimized in the heat exchanger according to the fourth aspect, and manufacturing costs can therefore be limited.

[0011] A heat exchanger according to a fifth aspect of the present invention is the heat exchanger according to the fourth aspect, wherein the sub-channel-forming member further comprises a tube-immobilizing member for immobilizing the end parts of the first flat tube and the second flat tube along with the tube-adhering member.

[0012] A heat exchanger according to a sixth aspect of the present invention is the heat exchanger according to any of the first through fifth aspects, wherein the sub-channel-forming member forms a plurality of the first sub-channels and a plurality of the second sub-channels.

[0013] A heat exchanger according to a seventh aspect of the present invention is the heat exchanger according to any of the first through sixth aspects, wherein the first refrigerant and the second refrigerant are carbon dioxide.

## Effect of the Invention

[0014] The heat exchanger according to the first through seventh aspects of the present invention can be made more compact. The manufacturing costs of the heat exchanger according to the fourth through sixth aspects of the present invention can be limited.

## BRIEF DESCRIPTION OF THE DRAWINGS

[0015] FIG. 1 is a schematic diagram of an air-conditioning device of an embodiment of the present invention;

[0016] FIG. 2 is a front view of an economizer heat exchanger of the embodiment of the present invention;

[0017] FIG. 3 is a top view of the economizer heat exchanger of the embodiment of the present invention;

[0018] FIG. 4 is a cross-sectional view in a horizontal direction of the economizer heat exchanger of the embodiment of the present invention;

[0019] FIG. 5 is a cross-sectional view in a horizontal direction of the economizer heat exchanger of the embodiment of the present invention;

[0020] FIG. 6 is a cross-sectional view in a vertical direction of the economizer heat exchanger of the embodiment of the present invention;

[0021] FIG. 7 is a cross-sectional view in a vertical direction of the economizer heat exchanger of the embodiment of the present invention;

[0022] FIG. 8 is an exterior view of a channel-forming member of the embodiment of the present invention;

[0023] FIG. 9 is a cross-sectional view of a first flat porous tube and a second flat porous tube of the embodiment of the present invention;

[0024] FIG. 10 is a front view of a tube-adhering member of the embodiment of the present invention;

[0025] FIG. 11 is a front view of a tube-immobilizing member of the embodiment of the present invention;

[0026] FIG. 12 is a front view of a spacer member of the embodiment of the present invention;

[0027] FIG. 13 is a drawing showing flow of a refrigerant within the economizer heat exchanger of the embodiment of the present invention;

[0028] FIG. 14 is an exterior view of a header and flat porous tubes of the economizer heat exchanger of the embodiment of the present invention; and

[0029] FIG. 15 is an exterior view of a header and flat porous tubes of a conventional refrigerant-refrigerant heat exchanger.

## DESCRIPTION OF EMBODIMENTS

[0030] An embodiment of a heat exchanger according to the present invention will be described below on the basis of the drawings. The embodiment of the heat exchanger according to the present invention is a specific example of the present invention and does not limit the technical scope of the present invention.

[0031] (1) Configuration of Air-Conditioning Device

[0032] FIG. 1 is a schematic diagram of an air-conditioning device 1 that serves as an example of a refrigerating device provided with a heat exchanger according to the present invention. The air-conditioning device 1 has a refrigerant circuit 10 configured so as to allow air-cooling operations, uses carbon dioxide or another refrigerant active in the supercritical region, and performs a two-stage compression refrigeration cycle. The refrigerant circuit 10 primarily has a com-

pression mechanism 2, a heat-source-side heat exchanger 3, an expansion mechanism 4, a usage-side heat exchanger 5, and an economizer heat exchanger 6. These components will be described next.

[0033] (1-1) Compression Mechanism

[0034] The compression mechanism 2 compresses refrigerant from a low pressure in the refrigeration cycle to a high pressure in the refrigeration cycle. The compression mechanism 2 is a compressor 21 that uses two compression elements and compresses the refrigerant in two stages. The compressor 21 has an airtight structure that accommodates a compression-element-driving motor 21*b*, a drive shaft 21*c*, a first-stage compression element 2*c*, and a second-stage compression element 2*d* in a casing 21*a*. The compression-element-driving motor 21*b* is linked to the drive shaft 21*c*. The drive shaft 21*c* is linked to the first-stage compression element 2*c* and the second-stage compression element 2*d*. In other words, the compressor 21 has a uniaxial two-stage compression structure in which the compression-element-driving motor 21*b* drives the first-stage compression element 2*c* and the second-stage compression element 2*d* via the single drive shaft 21*c*.

[0035] The compressor 21 takes in low-pressure refrigerant from an intake tube 2*a*, uses the first-stage compression element 2*c* to compress the refrigerant taken in, and then discharges compressed intermediate-pressure refrigerant to an intermediate-pressure-refrigerant tube 7. The compressor 21 then takes in the intermediate-pressure refrigerant discharged to the intermediate-pressure-refrigerant tube 7, uses the second-stage compression element 2*d* to compress the refrigerant taken in, and then discharges the compressed high-pressure refrigerant to a discharge tube 2*b*.

[0036] (1-2) Heat-Source-Side Heat Exchanger

[0037] The heat-source-side heat exchanger 3 is a radiator for cooling the high-pressure refrigerant compressed by the compression mechanism 2. The heat-source-side heat exchanger 3 causes heat exchange between air, which acts as a coolant source, and the refrigerant flowing within the heat-source-side heat exchanger 3. The heat-source-side heat exchanger 3 is connected to the compression mechanism 2 via a first high-pressure refrigerant tube 3*a* and the discharge tube 2*b*. The first high-pressure refrigerant tube 3*a* is connected to an inlet of the heat-source-side heat exchanger 3 and to the discharge tube 2*b*. The heat-source-side heat exchanger 3 is connected to the economizer heat exchanger 6 and an injection part 8, which will be described hereinafter, via a second high-pressure refrigerant tube 3*b*. The second high-pressure refrigerant tube 3*b* is connected to an outlet of the heat-source-side heat exchanger 3, to an inlet of the economizer heat exchanger 6 (an inlet of a channel for refrigerant sent from the heat-source-side heat exchanger 3 to the expansion mechanism 4) and to an inlet of the injection part 8 (an inlet of a channel for refrigerant diverted from the second high-pressure refrigerant tube 3*b*).

[0038] (1-3) Expansion Mechanism

[0039] The expansion mechanism 4 decompresses the high-pressure refrigerant, which was cooled in the heat-source-side heat exchanger 3 and the economizer heat exchanger 6, to near the low pressure of the refrigeration cycle before sending the refrigerant to the usage-side heat exchanger 5. The expansion mechanism 4 is, e.g., an electrically operated expansion valve. The expansion mechanism 4 is connected to the economizer heat exchanger 6 via a third high-pressure refrigerant tube 3*c*. The third high-pressure

refrigerant tube 3c is connected to an outlet of the economizer heat exchanger 6 (an outlet of a channel for refrigerant sent from the heat-source-side heat exchanger 3 to the expansion mechanism 4) and to an inlet of the expansion mechanism 4. The expansion mechanism 4 is connected to the usage-side heat exchanger 5 via a first low-pressure refrigerant tube 5a. The first low-pressure refrigerant tube 5a is connected to an outlet of the expansion mechanism 4 and to an inlet of the usage-side heat exchanger 5.

**[0040]** (1-4) Usage-Side Heat Exchanger

**[0041]** The usage-side heat exchanger 5 is an evaporator for heating and evaporating the low-pressure refrigerant that was decompressed by the expansion mechanism 4. The usage-side heat exchanger 5 causes heat exchange between air, which serves as a heat source, and the refrigerant flowing within the usage-side heat exchanger 5. The usage-side heat exchanger 5 is connected to the expansion mechanism 4 via the first low-pressure refrigerant tube 5a. The usage-side heat exchanger 5 is connected to the compression mechanism 2 via a second low-pressure refrigerant tube 5b. The second low-pressure refrigerant tube 5b is connected to an outlet of the usage-side heat exchanger 5 and to the intake tube 2a.

**[0042]** (1-5) Economizer Heat Exchanger

**[0043]** The economizer heat exchanger 6 causes heat exchange between the high-pressure refrigerant sent from the heat-source-side heat exchanger 3 to the expansion mechanism 4 and the intermediate-pressure refrigerant flowing through the injection part 8.

**[0044]** The injection part 8 diverts the high-pressure refrigerant flowing from the heat-source-side heat exchanger 3 to the expansion mechanism 4 and returns the refrigerant to the inlet of the second-stage compression element 2d. Specifically, the injection part 8 diverts refrigerant from the second high-pressure refrigerant tube 3b and returns the refrigerant to the intermediate-pressure-refrigerant tube 7. The injection part 8 comprises a first injection tube 8a and a second injection tube 8b. The first injection tube 8a connects the second high-pressure refrigerant tube 3b with an inlet of the economizer heat exchanger 6 (an inlet of a channel for refrigerant diverted from the second high-pressure refrigerant tube 3b). The second injection tube 8b connects an outlet of the economizer heat exchanger 6 (an outlet of a channel for refrigerant diverted from the second high-pressure refrigerant tube 3b) with the intermediate-pressure-refrigerant tube 7. An injection valve 8c that functions as a return valve having a controllable opening degree is provided to the first injection tube 8a. The injection valve 8c is, e.g., an electrically operated expansion valve. The injection valve 8c decompresses the high-pressure refrigerant diverted from the second high-pressure refrigerant tube 3b to around the intermediate pressure of the refrigerant flowing within the intermediate-pressure-refrigerant tube 7.

**[0045]** In the economizer heat exchanger 6, the high-pressure refrigerant sent from the heat-source-side heat exchanger 3 to the expansion mechanism 4 is cooled by heat exchange with the intermediate-pressure refrigerant flowing through the injection part 8. Meanwhile, the intermediate-pressure refrigerant flowing through the injection part 8 is heated and evaporated by heat exchange with the high-pressure refrigerant, which is sent from the heat-source-side heat exchanger 3 to the expansion mechanism 4, while temporarily flowing in a gas-liquid two-phase state. After passing through the second injection tube 8b, the evaporated interme-

mediate-pressure refrigerant merges with the refrigerant flowing through the intermediate-pressure-refrigerant tube 7.

**[0046]** (2) Action of the Air-Conditioning Device

**[0047]** The action of the air-conditioning device I during air-cooling operations will be described next on the basis of the flow of refrigerant circulating through the refrigerant circuit 10. The refrigerant at the low pressure of the refrigeration cycle is taken in from the intake tube 2a to the compression mechanism 2. The low-pressure refrigerant taken in to the compression mechanism 2 is compressed to the intermediate pressure of the refrigeration cycle by the first-stage compression element 2c and then discharged to the intermediate-pressure-refrigerant tube 7, in the intermediate-pressure-refrigerant tube 7, the intermediate-pressure refrigerant discharged from the first-stage compression element 2c is merged with the intermediate-pressure refrigerant returned from the second injection tube 8b. The merged intermediate-pressure refrigerant is taken in to the second-stage compression element 2d and compressed to the high pressure of the refrigeration cycle by the second-stage compression element 2d. The compressed high-pressure refrigerant is discharged from the compression mechanism 2 to the discharge tube 2b.

**[0048]** The high-pressure refrigerant discharged from the compression mechanism 2 is sent through the first high-pressure refrigerant tube 3a to the heat-source-side heat exchanger 3. The high-pressure refrigerant sent to the heat-source-side heat exchanger 3 is subjected to heat exchange with outside air and cooled by the heat-source-side heat exchanger 3. A portion of the high-pressure refrigerant cooled by the heat-source-side heat exchanger 3 is diverted in the second high-pressure refrigerant tube 3b to the first injection tube 8a. The high-pressure refrigerant diverted to the first injection tube 8a is decompressed to around the intermediate pressure of the refrigeration cycle by the injection valve 8c and is then sent to the economizer heat exchanger 6. Meanwhile, the high-pressure refrigerant subsequent to the diversion to the first injection tube 8a (i.e., refrigerant flowing through the second high-pressure refrigerant tube 3b) is sent to the economizer heat exchanger 6.

**[0049]** In the economizer heat exchanger 6, the high-pressure refrigerant from the second high-pressure refrigerant tube 3b is subjected to heat exchange with the intermediate-pressure refrigerant from the first injection tube 8a and cooled. Meanwhile, the intermediate-pressure refrigerant from the first injection tube 8a is subjected to heat exchange with the high-pressure refrigerant from the second high-pressure refrigerant tube 3b, heated, and returned through second injection tube 8b to the intermediate-pressure-refrigerant tube 7.

**[0050]** The high-pressure refrigerant cooled in the economizer heat exchanger 6 is sent through the third high-pressure refrigerant tube 3c to the expansion mechanism 4. The high-pressure refrigerant sent to the expansion mechanism 4 is decompressed by the expansion mechanism 4, enters a gas-liquid two-phase state at the low pressure of the refrigeration cycle, and is sent through the first low-pressure refrigerant tube 5a to the usage-side heat exchanger 5. The low-pressure, gas-liquid two-phase refrigerant sent to the usage-side heat exchanger 5 is subjected to heat exchange with outside air, heated, and evaporated by the usage-side heat exchanger 5. The low-pressure refrigerant that was heated and evaporated by the usage-side heat exchanger 5 is once again taken in to the compression mechanism 2 through the second low-pressure refrigerant tube 5b and the intake tube 2a. The air-

conditioning device 1 thus circulates refrigerant within the refrigerant circuit 10 and performs air-cooling operations.

**[0051]** (3) Detailed Configuration of the Economizer Heat Exchanger

**[0052]** The detailed configuration of the economizer heat exchanger 6 will be described next. The economizer heat exchanger 6 in the present embodiment is a heat exchanger according to the present invention. FIG. 2 is a front view of the economizer heat exchanger 6. FIG. 3 is a top view of the economizer heat exchanger 6. FIG. 2 is a front view from the direction of an arrow II shown in FIG. 3. FIG. 3 is a top view from the direction of an arrow III shown in FIG. 2. FIGS. 4 and 5 are cross-sectional views in a horizontal direction cut along cut line IV-IV and cut line V-V, respectively, in FIG. 2. FIGS. 6 and 7 are cross-sectional views in a vertical direction cut along cut line VI-VI and cut line VII-VII, respectively, in FIG. 3. The economizer heat exchanger 6 primarily comprises a pair of headers 61, a plurality of first flat porous tubes 64a, and a plurality of second flat porous tubes 64b. These components will be described next.

**[0053]** (3-1) Headers

**[0054]** Both of the pair of the headers 61 have the same structure, and therefore only one of the headers 61 will be described below. The header 61 is positioned so that the longitudinal direction thereof proceeds along the vertical direction. The header 61 has a channel-forming member 62, and a tube-connecting member 63. The channel-forming member 62 has, therein, a first primary channel 62a1, a second primary channel 62a2, a plurality of first linking channels 62b1, and a plurality of second linking channels 62b2. The first linking channels 62b1 and the second linking channels 62b2 are communicated with the first primary channel 62a1 and the second primary channel 62a2, respectively, as shown in FIGS. 4 through 7. FIG. 8 is an exterior view of the channel-forming member 62 seen from an arrow VIII in FIG. 4. The first linking channels 62b1 and the second linking channels 62b2 open in alternation along the longitudinal direction of the channel-forming member 62 on an opening surface 62s of the channel-forming member 62, as shown in FIG. 8. The first linking channels 62b1 open on the opening surface 62s along the first primary channel 62a1, and the second linking channels 62b2 open on the opening surface 62s along the second (primary channel 62a2).

**[0055]** The high-pressure refrigerant from the second high-pressure refrigerant tube 3b flows in the first primary channel 62a1 and the first linking channels 62b1. The intermediate-pressure refrigerant from the first injection tube 8a flows in the second (primary channel 62a2 and the second linking channels 62b2. Refrigerant in the first primary channel 62a flows in the vertical direction, and refrigerant in the first linking channels 62b1 is diverted from the first primary channel 62a1 and flows in a horizontal direction. Refrigerant in the second primary channel 62a2 flows in the vertical direction, and refrigerant in the second linking channels 62b2 is diverted from the second primary channel 62a2 and flows in the horizontal direction.

**[0056]** The tube-connecting member 63 connects the channel-forming member 62, the first flat porous tubes 64a, and the second flat porous tubes 64b. The detailed configuration of the tube-connecting member 63 will be described hereinafter.

**[0057]** (3-2) First flat Porous Tubes and Second Flat Porous Tubes

**[0058]** The first flat porous tubes 64a have a plurality of first refrigerant-channel holes 65a. The first flat porous tubes 64a are positioned so that the alignment direction of the first refrigerant-channel holes 65a is in the horizontal direction, i.e., so that the normal to the flat surface indicates the vertical direction. The second flat porous tubes 64b have a plurality of second refrigerant-channel holes 65b. The second flat porous tubes 64b are positioned so that the alignment direction of the second refrigerant-channel holes 65b is in the horizontal direction, i.e., so that the normal to the flat surface indicates the vertical direction.

**[0059]** Pairs of a single one of the first flat porous tubes 64a and a single one of the second flat porous tubes 64b, which are brought into close contact at the flat surfaces, are positioned at a plurality of stages along the longitudinal direction of the header 61 in the present embodiment, as shown in FIG. 2. Both end parts of the first flat porous tubes 64a and the second flat porous tubes 64b are linked respectively to the pair of the headers 61.

**[0060]** FIG. 9 is a cross-sectional view of the first flat porous tubes 64a and the second flat porous tubes 64b cut along a cut line IX-IX in FIG. 3. The alignment direction of the first refrigerant-channel holes 65a of the first flat porous tubes 64a and the alignment direction of the second refrigerant-channel holes 65b of the second flat porous tubes 64b are perpendicular to the longitudinal direction of the headers 61, as shown in FIG. 9.

**[0061]** (3-3) Tube-Connecting Member

**[0062]** The tube-connecting member 63 is configured from a tube-adhering member 63a, a tube-immobilizing member 63b, and a spacer member 63c, as shown in FIGS. 4 through 7. FIG. 10 is a front view of the tube-adhering member 63a. FIG. 11 is a front view of the tube-immobilizing member 63b. FIG. 12 is a front view of the spacer member 63c. FIGS. 10 through 12 are all external views from an arrow VIII in FIG. 4.

**[0063]** The tube-adhering member 63a has a U-shaped cross-section when viewed along the vertical direction, as shown in FIGS. 4 through 7. In the tube-adhering member 63a, a plurality of flat-tube-fitting insertion holes 63a1 are positioned in the vertical direction, as shown in FIG. 10. End parts of the first flat porous tubes 64a and the second flat porous tubes 64b are fit into the respective flat-tube-fitting insertion holes 63a1. The flat-tube-fitting insertion holes 63a1 immobilize the end parts of the first flat porous tubes 64a and the second flat porous tubes 64b.

**[0064]** The tube-immobilizing member 63b is a plate-shaped member positioned in close contact with the tube-adhering member 63a and the spacer member 63c in a space surrounded by the tube-adhering member 63a and the channel-forming member 62, as shown in FIGS. 4 through 7. A plurality of flat-tube-fastening holes 63b1 are positioned in the vertical direction in the tube-immobilizing member 63b, as shown in FIG. 11. The flat-tube-fastening holes 63b1 have two convex parts 63b2 at a center part in the horizontal direction. Along with the flat-tube-fitting insertion holes 63a1, the convex parts 63b2 immobilize the end parts of the first flat porous tubes 64a and the second flat porous tubes 64b. The height of the convex parts 63b2 is less than the thickness of the first flat porous tubes 64a and the second flat porous tubes 64b.

[0065] The spacer member 63c is a plate-shaped member positioned in close contact with the tube-immobilizing member 63b and the opening surface 62s of the channel-forming member 62 in a space surrounded by the tube-adhering member 63a and the channel-forming member 62, as shown in FIGS. 4 through 7. In the spacer member 63c, a plurality of spacer holes 63c1 are positioned in the vertical direction, as shown in FIG. 12. A portion of the end surface of the first flat porous tubes 64a and the second flat porous tubes 64b contacts the end surface of the spacer member 63c, as shown in FIGS. 4 and 5.

[0066] The height-wise positions of the first linking channels 62b1 and the second linking channels 62b2 that open on the opening surface 62s of the channel-forming member 62 in the present embodiment are equivalent to the height-wise positions of the flat-tube-fitting insertion holes 63a1, flat-tube-fastening holes 63b1, and the spacer holes 63c1. The first refrigerant-channel holes 65a and the second refrigerant-channel holes 65b are thereby communicated with the first linking channels 62b1 and the second linking channels 62b2, respectively, via the spacer holes 63c1. Below, the spacer holes 63c1 that is communicated with the first linking channels 62b1 will be called first sub-channels 62c1, and the spacer holes 63c1 that is communicated with the second linking channels 62b2 will be called second sub-channels 62c2. The first sub-channels 62c1 are spaces that, along with the first linking channels 62b1, allow the first refrigerant-channel holes 65a to be communicated with the first primary channel 62a1. The second sub-channels 62c2 are spaces that, along with the second linking channels 62b2, allow the second refrigerant-channel holes 65b to be communicated with the second primary channel 62a2.

[0067] (4) Flow of Refrigerant in the Economizer Heat Exchanger

[0068] Heat exchange in the economizer heat exchanger 6 will be described with reference to FIG. 13. The high-pressure refrigerant that is cooled by the heat-source-side heat exchanger 3 and made to flow through the second high-pressure refrigerant tube 3b is provided to the first primary channel 62a1 within one of the headers 61 of the economizer heat exchanger 6. The high-pressure refrigerant flowing through the first primary channel 62a1 is split into the first sub-channels 62c1 via the first linking channels 62b1 and flows into the first refrigerant-channel holes 65a of the first flat porous tubes 64a.

[0069] Meanwhile, the intermediate-pressure refrigerant, which was diverted from the second high-pressure refrigerant tube 3b, decompressed by the injection valve 8c, and made to flow through the first injection tube 8a, is supplied to the second (primary channel 62a2 within the header 61 on the opposite side from the header to which the high-pressure refrigerant is supplied. The intermediate-pressure refrigerant flowing through the second primary channel 62a2 is split into the second sub-channels 62c2 via the second linking channels 62b2 and flows into the second refrigerant-channel holes 65b of the second flat porous tubes 64b.

[0070] The high-pressure refrigerant flowing through the first refrigerant-channel holes 65a of the first flat porous tubes 64a exchanges heat with the intermediate-pressure refrigerant O flowing through the second refrigerant-channel holes 65b of the second flat porous tubes 64b that are in close contact with the first flat porous tubes 64a. The direction of flow of the high-pressure refrigerant in the first refrigerant-channel holes 65a is opposite from the direction of flow of the

intermediate-pressure refrigerant in the second refrigerant-channel holes 65b, as shown in FIG. 13.

[0071] The high-pressure refrigerant that has passed through the first refrigerant-channel holes 65a and been subjected to heat exchange flows into the first primary channel 62a1 within the header 61 on the opposite side. Finally, the high-pressure refrigerant is sent from the first primary channel 62a1 to the third high-pressure refrigerant tube 3c. Meanwhile, the intermediate-pressure refrigerant that has passed through the second refrigerant-channel holes 65b and been subjected to heat exchange flows into the second primary channel 62a2 within the header 61 on the opposite side. Finally, the intermediate-pressure refrigerant is sent from the second primary channel 62a2 to the second injection tube 8b.

[0072] (5) Characteristics

[0073] In the economizer heat exchanger 6 of the present embodiment, the high-pressure refrigerant that flows through the first primary channel 62a1 of the header 61 is split into the first sub-channels 62c1 and then flows into the first refrigerant-channel holes 65a of the first flat porous tubes 64a. The intermediate-pressure refrigerant that flows through the second primary channel 62a2 of the header 61 is split into the second sub-channels 62c2 and then flows into the second refrigerant-channel holes 65b of the second flat porous tubes 64b. The first sub-channels 62c1 and the second sub-channels 62c2 are spaces formed by the tube-connecting member 63.

[0074] In the economizer heat exchanger 6, the first flat porous tubes 64a and the second flat porous tubes 64b are linked to the headers 61 on that the alignment direction of the first refrigerant-channel holes 65a of the first flat porous tubes 64a and the alignment direction of the second refrigerant-channel holes 65b of the second flat porous tubes 64b are perpendicular to the longitudinal direction of the headers 61, as shown in FIG. 14. The tube-connecting member 63 that forms the first sub-channels 62c1 and the second sub-channels 62c2 is used in the present embodiment, whereby the first flat porous tubes 64a and the second flat porous tubes 64b can be linked to the headers 61, as shown in FIG. 14.

[0075] In a conventional heat exchanger such as shown in FIG. 15, a plurality of flat porous tubes are linked to headers so that the alignment direction of refrigerant-channel holes within the flat porous tubes proceeds along a longitudinal direction of the headers. The headers in this heat exchanger must be long in order to link the plurality of the flat porous tubes to the headers, and this heat exchanger is therefore not readily made more compact. On the other hand, in the economizer heat exchanger 6 of the present embodiment as shown in FIG. 14, the plurality of the flat porous tubes 64a, 64b can be efficiently linked to the headers 61, and therefore the length of the header 61 can be reduced in comparison to the conventional heat exchanger shown in FIG. 15. The economizer heat exchanger 6 of the present embodiment can therefore readily be made more compact.

[0076] (6) Modifications

[0077] (6-1) Modification A

[0078] The economizer heat exchanger 6 was described as the heat exchanger according to the present invention in the present embodiment, but the heat exchanger according to the present invention can be applied generally to heat exchangers for causing heat exchange between a refrigerant and a refrigerant.

[0079] (6-2) Modification B

[0080] In the present embodiment, the first flat porous tubes 64a and the second flat porous tubes 64b are linked to the

headers **61** so that the alignment directions of the first refrigerant-channel holes **65a** and the second refrigerant-channel holes **65b** are perpendicular to the longitudinal direction of the header **61**, but it may be applicable as long as the alignment directions of the first refrigerant-channel holes **65a** and the second refrigerant-channel holes **65b** intersect the longitudinal direction of the header **61**.

[0081] Even in the present modification, the plurality of the flat porous tubes **64a**, **64b** can be efficiently linked to the headers **61** in comparison to a conventional heat exchanger such as shown in FIG. 15, and therefore the length of the headers **61** can be reduced. The economizer heat exchanger **6** of the present modification can therefore also be readily made more compact.

#### INDUSTRIAL APPLICABILITY

[0082] The heat exchanger according to the present invention can be readily made more compact.

#### REFERENCE SIGNS LIST

- [0083] **6** Economizer heat exchanger (heat exchanger)
- [0084] **61** Header
- [0085] **62a1** First primary channel
- [0086] **62a2** Second primary channel
- [0087] **63** Tube-connecting member (sub-channel-forming member)
- [0088] **63a** Tube-adhering member
- [0089] **63b** Tube-immobilizing member
- [0090] **62c1** First sub-channels
- [0091] **62c2** Second sub-channels
- [0092] **64a** First flat porous tubes (first flat tubes)
- [0093] **64b** Second flat porous tubes (second flat tubes)
- [0094] **65a** First refrigerant-channel holes
- [0095] **65b** Second refrigerant-channel holes

#### CITATION LIST

##### PATENT LITERATURE

[0096] [Patent Document 1] Japanese Laid-Open Patent Application No 2007-163004

1. A heat exchanger, comprising:
  - a header having a first primary channel and a second primary channel with a first refrigerant flowing through the first primary channel, and a second refrigerant flowing through the second primary channel;
  - a first flat tube linked to the header and having a plurality of first refrigerant-channel holes, the first refrigerant flowing through the first refrigerant-channel holes, and the first flat tube being a flat porous tube; and
  - a second flat tube linked to the header and having a plurality of second refrigerant-channel holes, the second refrigerant flowing through the second refrigerant-channel holes, and the second flat tube being a flat porous tube, the header having a sub-channel-forming member that forms at least one first sub-channel and at least one second sub-channel, the first sub-channel allowing the first primary channel to be communicated with the first refrigerant-channel holes, and the second sub-channel allowing the second primary channel to be communicated with the second refrigerant-channel holes; and
  - the first flat tube and the second flat tube being in close contact, and heat being exchanged between the first refrigerant flowing through the first refrigerant-channel

- holes and the second refrigerant flowing through the second refrigerant-channel holes.
- 2. The heat exchanger according to claim 1, wherein the first flat tube and the second flat tube are linked to the header so that a cross-sectional longitudinal direction intersects a longitudinal direction of the header, the cross-sectional longitudinal direction extending along alignment directions of the first refrigerant-channel holes and the second refrigerant-channel holes.
- 3. The heat exchanger according to claim 2, wherein the first flat tube and the second flat tube are linked to the header so that the cross-sectional longitudinal direction is perpendicular to the longitudinal direction of the header.
- 4. The heat exchanger according to claim 1, wherein the sub-channel-forming member includes a tube-adhering member, end parts of the first flat tube and the second flat tube are adhered to the tube-adhering member, and the tube-adhering member is immobilized on the header.
- 5. The heat exchanger according to claim 4, wherein the sub-channel-forming member further includes a tube-immobilizing member that immobilizes the end parts of the first flat tube and the second flat tube along with the tube-adhering member.
- 6. The heat exchanger according to claim 1, wherein the at least one first sub-channel includes a plurality of first sub-channels and the at least one second sub-channel includes a plurality of second sub-channels.
- 7. The heat exchanger according to claim 1, wherein the first refrigerant and the second refrigerant are carbon dioxide.
- 8. The heat exchanger according to claim 2, wherein the sub-channel-forming member includes a tube-adhering member, end parts of the first flat tube and the second flat tube are adhered to the tube-adhering member, and the tube-adhering member is immobilized on the header.
- 9. The heat exchanger according to claim 8, wherein the sub-channel-forming member further includes a tube-immobilizing member that immobilizes the end parts of the first flat tube and the second flat tube along with the tube-adhering member.
- 10. The heat exchanger according to claim 2, wherein the at least one first sub-channel includes a plurality of first sub-channels and the at least one second sub-channel includes a plurality of second sub-channels.
- 11. The heat exchanger according to claim 3, wherein the sub-channel-forming member includes a tube-adhering member, end parts of the first flat tube and the second flat tube are adhered to the tube-adhering member, and the tube-adhering member is immobilized on the header.
- 12. The heat exchanger according to claim 11, wherein the sub-channel-forming member further includes a tube-immobilizing member that immobilizes the end parts of the first flat tube and the second flat tube along with the tube-adhering member.
- 13. The heat exchanger according to claim 3, wherein the at least one first sub-channel includes a plurality of first sub-channels and the at least one second sub-channel includes a plurality of second sub-channels.
- 14. The heat exchanger according to claim 4, wherein the at least one first sub-channel includes a plurality of first sub-channels and the at least one second sub-channel includes a plurality of second sub-channels.

15. The heat exchanger according to claim 5, wherein the at least one first sub-channel includes a plurality of first sub-channels and the at least one second sub-channel includes a plurality of second sub-channels.

\* \* \* \* \*