

(No Model.)

J. A. BROWN.
AUTOMATIC WATERING TROUGH.

No. 551,027.

Patented Dec. 10, 1895.

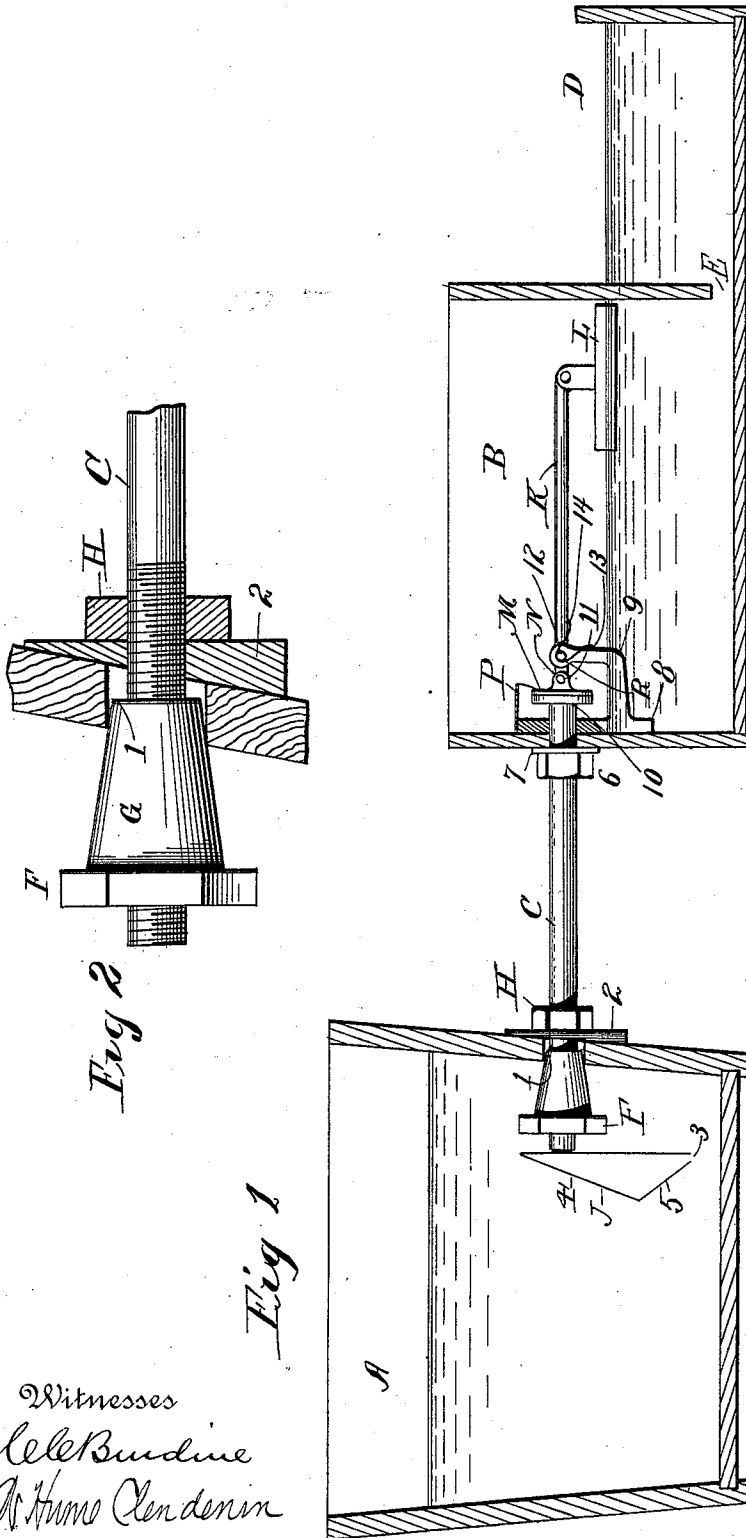

Fig 2

Fig 1

Witnesses
C. E. Budine
W. H. C. C. C. C.

Inventor
James A. Brown
per
J. G. Manahan
his Attorney.

UNITED STATES PATENT OFFICE.

JAMES A. BROWN, OF SUBLETTE, ILLINOIS.

AUTOMATIC WATERING-TROUGH.

SPECIFICATION forming part of Letters Patent No. 551,027, dated December 10, 1895.

Application filed April 12, 1893. Serial No. 470,074. (No model.)

To all whom it may concern:

Be it known that I, JAMES A. BROWN, a citizen of the United States, residing at Sublette, in the county of Lee and State of Illinois, have
5 invented certain new and useful Improvements in Automatic Watering-Troughs; and I do declare the following to be a full, clear, and exact description of the invention, such as will enable others skilled in the art to which
10 it appertains to make and use the same, reference being had to the accompanying drawings, and to the letters and figures of reference marked thereon, which form a part of this specification.

15 My invention has reference to automatic watering-troughs; and it consists of an improvement on the construction for which on July 5, 1892, Letters Patent of the United States No. 478,397 were granted to me.

20 The objection to the former method and to most if not all of the automatic watering-troughs heretofore in use where the same are governed by a float has been that the float has not sufficient power to hold the exit-valve
25 with the necessary force against the outlet end of the water-pipe, particularly where there is considerable head in the vessel from which the water is drawn, unless the float be made of such size as to be inconvenient and
30 to require a very large valve-box.

In my invention the purpose is to so arrange the fulcrum-point of the float-lever in
reference to the opening under the valve and the pivotal connection of said lever with the
35 valve that the three aforesaid points—to wit, the opening covered by the valve, the pivotal connection of the valve to the adjacent end of the float-lever, and the fulcrum of the said
40 lever—shall be in a line when the valve is seated, whereby the short end of the float-lever acts as a lock and is held in position against the pressure of the water by a very slight supporting-float at the longer end of
said lever.

45 My invention also comprises a nut having a tapering lateral elongation or sleeve adapted to encircle the end of the supply-pipe which projects into the supply-tank and to be forced
into the opening in the latter around said pipe,
50 and thereby seal said opening outside of said pipe so tightly as to prevent the usual drip-

ping of water occasioned by the pressure in the supply-tank.

My invention also comprises the placing of
a hood over the inlet end of the supply-tube
55 within the supply-tank, such hood having the inlet-opening 3 in its lower end and having its inner side oblique, whereby the water rising over the lower end of said hood forces the
60 material floating on the surface of the water away from said inlet, and also when the water lowers from an altitude above the said hood said inclined side tends to force the floating
material away from the bottom of the hood.

I obtain these advantages by the construction
65 shown in the accompanying drawings, in which—

Figure 1 is a side elevation of the operative
portions, the supply tank or reservoir, valve-
chamber, and drinking-trough being cut away
70 for the purpose of exposing the interior. Fig. 2 is a detail of the sealing-nut before referred to.

A is the usual supply-tank or water-reservoir from which it is intended to draw the
water. B is the valve-chamber, communicating
75 with the supply-tank by means of a tube C, of sufficient length to extend slightly through the adjacent walls of said chamber and tank.

D is the drinking-trough, formed against the
valve-chamber B and communicating there-
80 with through the inlet E at the bottom of the partition between B and D.

The end of the tube C which projects within
the tank A is threaded to receive a nut F,
integral with which is formed the tapering
85 sleeve G, adapted at its outer and smaller end to project into the opening 1, through which the tube C enters the tank A, and in
tightening the nut F the sleeve G is wedged
90 into said opening, thereby preventing the escape of the water through the same around the tube C.

H is an ordinary nut seated on the tube C
outside of the tank A to receive the drawing
action of the nut F. A wedge-shaped washer
95 2 is interposed between the nut H and the flaring side of the tank A.

J is a hood having a hollow interior suitably seated on and communicating with the
inlet end of the tube C and having also a
100 water-inlet 3 at its lower end. The side of the hood J opposite the pipe C is formed of

two angular sides 4 and 5, the latter projecting diagonally upward toward the center of the tank and the side 4 projecting diagonally upward from said center.

5 The tube C is threaded a short distance outside of the chamber B, and a nut 6, seated on said tube, with an interposed washer 7, seals the opening into the valve-chamber. Around the exit of the tube C within the valve-chamber there is seated against the wall of the latter a plate 8, to which is rigidly fixed the lower end of the standard 9, which is turned upward into the horizontal plane of the outlet of the tube C to serve as a fulcrum for the valve-lever K, and to the outer end of the lever is pivotally attached the float L.

10 Within the standard 9 and against the outer end 10 of the pipe C there is located the valve M, to the inner side of which there are centrally attached short horizontal ears N, to which the adjacent end of the lever K is pivoted at 11. The lever K is fulcrumed at the upper end 12 of the standard 9 in the horizontal plane of the pipe end 10 and the valve-pivot 11 when said valve is closed, in which position the lever K is substantially horizontal. Whenever the water is of sufficient height in the valve-chamber to carry the valve-lever K into a horizontal position it will be seen that the points 10, 11, and 12 are in the same horizontal line, when, the outward pressure of the water through the tube C being in the line of the pivot 11 and fulcrum-point 12, but a slight lifting action of the float L is necessary to keep the valve M seated.

35 As the float L descends with the depletion of the water the lower end of the valve M is turned away from the exit 10, permitting the

water to escape into the valve-chamber until such time as the lever K is again carried by the float L into a horizontal position.

P is a half-spherical hood seated on plate 8 and serving to cover the valve M. A spring R, coiled on the fulcrum 12, has its one end 13 bearing against standard 9 and the other end 14 under lever K to assist the float L in rising.

I find by experience that spring R is of great advantage in the combination to which it contributes, as it helps the float L to seat the valve M against the water-pressure in reservoir A, whereby I can use a smaller float and a smaller chamber for it. The weight of the lever and pressure of the water will open the valve against the spring.

What I claim as my invention, and desire to secure by Letters Patent of the United States, is—

The combination of the reservoir A, provided with opening 1, tube C, projected, from the outside, a short distance within said reservoir, nut H, seated on said tube, outside of and against said reservoir, nut F, provided with tapering sleeve G, seated on said tube within said reservoir, with said sleeve projected into opening 1 around said tube, and the hood J, seated on the inner extremity of said tube and provided at its lower end with inlet 3 and with the interior angular sides 4 and 5, substantially as shown and for the purpose described.

In testimony whereof I affix my signature in presence of two witnesses.

JAMES A. BROWN.

Witnesses:

WM. E. BROWN,
HANNAH A. BROWN.