

(No Model.)

G. W. CHASE.
INDICATOR.

No. 437,480.

Patented Sept. 30, 1890.

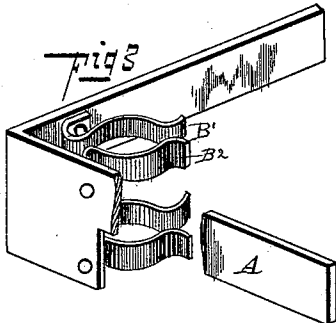
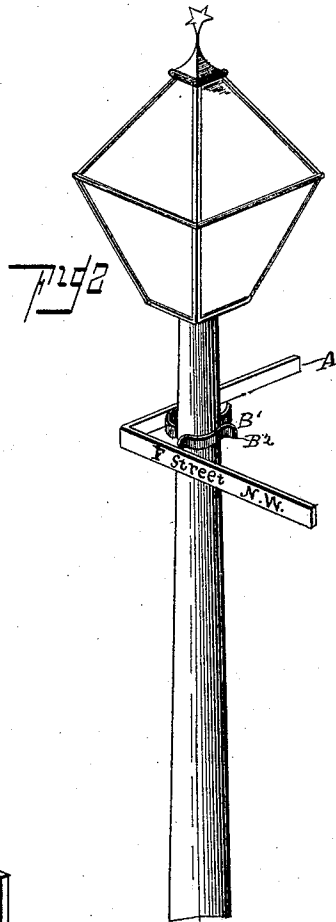
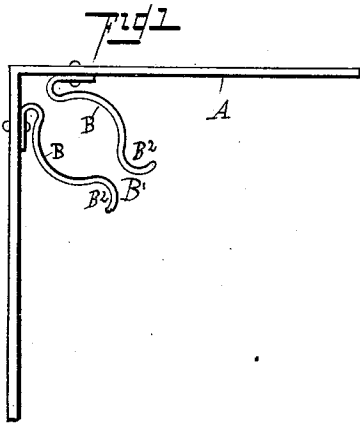

WITNESSES
T. Willoughby
J. F. Reitz

Geo. W. Chase
INVENTOR

By *W. S. Fitzgerald*
Attorney

UNITED STATES PATENT OFFICE.

GEORGE W. CHASE, OF TONAWANDA, NEW YORK.

INDICATOR.

SPECIFICATION forming part of Letters Patent No. 437,480, dated September 30, 1890.

Application filed February 20, 1890. Serial No. 341,172. (No model.)

To all whom it may concern:

Be it known that I, GEORGE W. CHASE, a citizen of the United States, residing at Tonawanda, in the county of Erie and State of New York, have invented certain new and useful Improvements in Indicators; and I do hereby declare the following to be a full, clear, and exact description of the invention, such as will enable others skilled in the art to which it appertains to make and use the same.

My invention consists in a new and improved street-indicator, which is adapted to be attached in a moment to a lamp-post or the like without requiring any nuts, bolts, screws, or other similar additional fastening devices, and my invention will be hereinafter fully described and claimed.

Referring to the accompanying drawings, Figure 1 is a top plan view of my new and improved indicator. Fig. 2 is a perspective view showing the same attached in operative position to a street-lamp, and Fig. 3 is a perspective view showing the indicator provided with an additional pair of spring-arms.

The same letters of reference indicate corresponding parts in all the figures.

Referring to the several parts by letter, A indicates the body of the indicator proper, which is constructed by joining the ends of two pieces of sheet metal or other suitable material so that the plane of their bodies will be at right angles with each other; or the indicator may be formed of a single piece of sheet metal or other suitable material bent at its center so that its two halves stand at right angles to each other and parallel with the streets the names of which are placed on them. Within the angle thus formed by the junction of the two halves of the indicator are secured the inner ends of two spring-arms B B—one to each side, as shown. The inner ends of these spring-arms curve in toward each other at B¹, and the body of each arm then curves out in a half-circle B², the free ends B curving in toward each other and their extremities being curved outward to assist the entrance of the lamp-post between them when placing them in position.

The names of the streets to be designated are placed on both sides of the two parts of the body A, so that they can be read from both sides as a matter of convenience.

My indicators can be secured in position in a moment to any lamp-post or the like by simply pressing the free ends of the spring-arms B against the post, when the post will enter between the outwardly-curved extremities of their free ends, the spring-arms giving and opening as the post thus enters between them, springing or closing around the post, as will be clearly seen, and thus securing the indicator firmly in position without requiring the use of any nuts, screws, threaded bolts, or other fastening or tying devices.

From the foregoing description, taken in connection with the accompanying drawings, the construction, operation, and advantages of my new and improved indicator will be readily understood.

It will be seen that my indicator can be sprung or fixed in a moment on any lamp-post or similar object, thus effecting an immense saving in time and labor where a great number of indicators have to be put up, as in large cities, and also materially reducing the expense of the indicators.

The indicator may be provided with two pairs of spring-arms B, as shown in Fig. 3 of the drawings, to give it additional grasping or clamping power, as when used on a smooth wooden post, without departing in the least from my invention.

Having thus described my invention, what I claim, and desire to secure by Letters Patent, is—

1. A street-indicator of the described class, having open spring-retaining arms adapted to spring or close around a post or other similar object, substantially as set forth.

2. The indicator-body A, having the open spring-arms B B secured within its angle by their inner ends, substantially as and for the purpose set forth.

3. The combination of the indicator-body A and the curved open spring-arms B B, secured within the angle of the body A by their inner ends, substantially as set forth.

In testimony whereof I affix my signature in presence of two witnesses.

GEORGE W. CHASE.

Witnesses:

GEORGE F. KARNER,
JOHN G. BROWN.