



(19)

Europäisches Patentamt
European Patent Office
Office européen des brevets



(11)

EP 0 709 747 B1

(12)

EUROPEAN PATENT SPECIFICATION

(45) Date of publication and mention
of the grant of the patent:
22.03.2006 Bulletin 2006/12

(51) Int Cl.:
G03G 15/06^(2006.01) G03G 13/08^(2006.01)

(21) Application number: **95307715.3**

(22) Date of filing: **30.10.1995**

(54) **Selection of developing bias voltage for use in electrophotographic method using photosensitive material**

Entwicklungsvorspannungsauswahl zur Verwendung in einem elektrofotografischem Verfahren, welches fotoempfindliches Material verwendet

Selection de tension de polarisation de développement à utiliser dans une procédé électrophotographique utilisant du matériau photosensible

(84) Designated Contracting States:
DE FR GB IT

(30) Priority: **31.10.1994 JP 26779294**

(43) Date of publication of application:
01.05.1996 Bulletin 1996/18

(73) Proprietor: **KYOCERA MITA CORPORATION**
Chuo-ku ,
Osaka 540 (JP)

(72) Inventors:

- **Tsujita, Mitsuji,**
c/o Mita Industrial Co., Ltd.
Osaka 540 (JP)
- **Tanaka, Nariaki,**
c/o Mita Industrial Co., Ltd.
Osaka 540 (JP)
- **Terada, Takashi,**
c/o Mita Industrial Co., Ltd.
Osaka 540 (JP)
- **Terada, Takuji,**
c/o Mita Industrial Co., Ltd.
Osaka 540 (JP)
- **Yamazato, Ichiro,**
c/o Mita Industrial Co., Ltd.
Osaka 540 (JP)

• **Miyamoto, Eiichi,**
c/o Mita Industrial Co., Ltd.
Osaka 540 (JP)

(74) Representative: **Cresswell, Thomas Anthony**
J.A. KEMP & CO.
14 South Square
Gray's Inn
London WC1R 5JJ (GB)

(56) References cited:
EP-A- 0 338 962

- **PATENT ABSTRACTS OF JAPAN vol. 009, no. 177 (P-375), 23 July 1985 & JP 60 050538 A (TOYO INK SEIZO KK), 20 March 1985,**
- **PATENT ABSTRACTS OF JAPAN vol. 018, no. 567 (P-1820), 28 October 1994 & JP 06 208271 A (FUJI XEROX CO LTD), 26 July 1994,**
- **PATENT ABSTRACTS OF JAPAN vol. 016, no. 543 (P-1451), 12 November 1992 & JP 04 204876 A (MITA IND CO LTD), 27 July 1992,**
- **PATENT ABSTRACTS OF JAPAN vol. 017, no. 390 (P-1577), 21 July 1993 & JP 05 066638 A (RICOH CO LTD), 19 March 1993,**

Note: Within nine months from the publication of the mention of the grant of the European patent, any person may give notice to the European Patent Office of opposition to the European patent granted. Notice of opposition shall be filed in a written reasoned statement. It shall not be deemed to have been filed until the opposition fee has been paid. (Art. 99(1) European Patent Convention).

EP 0 709 747 B1

DescriptionBACKGROUND OF THE INVENTION

5 1. Field of the Invention

[0001] The present invention relates to an electrophotographic method by using a photosensitive material and, particularly, an organic photosensitive material and utilizing high-sensitivity characteristics with a small amount of exposure to light. More specifically, the invention relates to an electrophotographic method by which a photosensitive material and, particularly, a photosensitive material in which the loss of electric charge becomes mild at around a half amount of exposure to light is adapted to a high-speed electrophotographic system without generating fogging.

2. Description of the Prior Art

[0002] In an electrophotographic method, a photosensitive material for electrophotography is electrically charged, exposed to image-bearing light to form electrostatic latent image, which is then developed with toner in a state where a developing bias voltage is applied thereto, and the toner image that is formed is transferred to a transfer paper followed by fixing to form an image.

[0003] As a photosensitive material used for the electrophotographic method, there have heretofore been used a selenium photosensitive material and an amorphous silicon photosensitive material. In recent years, however, organic photosensitive materials (OPC) have been extensively used. Representative examples of the organic photosensitive materials include a laminated photosensitive material of the function-separated type in which a charge-generating agent (CGM) and a charge-transporting agent (CTM) are laminated as separate layers, and a single-layer photosensitive material in which CGM and CTM are provided as a single dispersion layer.

[0004] Among these organic photosensitive materials, the single-layer photosensitive material has a charge-generating agent that is dispersed in a resin medium in which a charge-transporting agent is dissolved. In some laminated-layer photosensitive materials, furthermore, the layer of charge-generating agent has the charge-generating agent dispersed in the resin medium.

[0005] When a photosensitive material is exposed to image-bearing light as shown in Fig. 1 which illustrates a relationship between the surface potential and the time, the potential in a dark portion (D) is attenuated only slightly in response to dark attenuation whereas the potential in a bright portion (L) is quickly attenuated in response to light attenuation, whereby a potential contrast adapted to developing is formed.

[0006] The sensitivity of the photosensitive material corresponds to the rate of light attenuation and is, generally, evaluated in terms of the amount of exposure to light needed for halving the potential relative to the initial potential of before being exposed to light, i.e., evaluated in terms of a half amount of exposure to light (lux x sec).

[0007] When the photosensitive material is exposed to light, the electric charge quickly attenuates up to nearly the half amount of exposure to light. As the amount of exposure exceeds the half amount of exposure to light, however, the electric charge attenuates mildly.

[0008] To prevent the fogging due to residual potential in a bright portion, on the other hand, the amount of exposure to light must be set to a considerably large value compared with the half amount of exposure to light.

[0009] For this purpose, a source of light having a large output is necessary and a large cooling fan is needed to remove the heat generated by the source of light, resulting in an increase in the cost of the apparatus and the cost of electric power. Moreover, exposing an organic photosensitive material to a large quantity of light causes the photosensitive material to be deteriorated. On the other hand, when the source of light having a small output is used, an extended period of time is required for the step of exposure to light imposing limitation on the speed of copying and on the printing speed in the facsimile or laser printer.

SUMMARY OF THE INVENTION

[0010] The object of the present invention, therefore, is select the bias voltage for image development so as to provide an electrophotographic method which is capable of forming vivid image without fogging and, particularly, capable of forming image with a small amount of exposure to light by utilizing high-sensitivity characteristics of a photosensitive material in the zone of a small amount of exposure to light.

[0011] An advantage of the present invention is to allow an electrophotographic method to be realized using a cheaply constructed device and consumes small amounts of resources and small amounts of energy by using an organic photosensitive material.

[0012] According to the present invention, there is provided a method as defined in claim 1.

[0013] The present invention can be advantageously applied to a photosensitive material in which the loss of electric

charge becomes mild at around a half amount of exposure to light and, particularly, to an organic photosensitive material of the type in which a charge-generating agent is dispersed and, preferably, to a single-dispersion-layer photosensitive material in which a charge-generating substance is dispersed in a resin medium that includes a charge-transporting substance and, most desirably, to a single-dispersion-layer photosensitive material of the positively charged type.

[0014] In the present invention, furthermore, it is desired that the amount of exposure to light in a bright portion is so set that the absolute value of a residual potential (ER) in the bright portion is smaller than the absolute value of the bias potential (EB) during the exposure to image-bearing light. How low the residual potential be set is determined as described below. That is, the amount of exposure to light in a bright portion is so set that the residual potential (ER) in the bright portion satisfies the formula (2),

$$ER = EB - nED0 \quad \dots (2)$$

where EB is a developing bias potential, EDO is a potential at which the fogging density becomes substantially zero in relation to developing sensitivity characteristics of a combination of the photosensitive material and the developing agent, and n is a number of from 0.4 to 2.5 and, most preferably, from 0.5 to 1.0, though it may vary depending upon a light attenuation curve of potential of the photosensitive material, applied bias potential, and developing sensitivity characteristics of the photosensitive material and of the developing agent.

BRIEF DESCRIPTION OF THE DRAWINGS

[0015]

Fig. 1 is a diagram explaining the change of the surface potential when a photosensitive material is being exposed to image-bearing light;

Fig. 2 is a graph illustrating a relationship (light attenuation characteristics) between the amount of exposure to light and the surface potential concerning photosensitive materials α , β , and γ of Examples;

Fig. 3 is a diagram illustrating a method of finding a point of intersection between a line approximating the zone of a large amount of exposure to light and a line approximating the zone of a small amount of exposure to light from the plots of logarithmic values of the surface potential and the amount of exposure to light;

Fig. 4 is a graph plotting a relationship (developing sensitivity characteristics) between the voltage applied to the developing sleeve and the optical density (I.D.) of the toner layer transferred (developed) onto the non-charged photosensitive layer concerning a combination of the negatively charged toner and the non-charged photosensitive layer;

Fig. 5 is a diagram illustrating the arrangement of a device (copying machine) used for the electrophotographic method of the present invention; and

Fig. 6 is a diagram of arrangement illustrating a developing device on an enlarged scale.

DETAILED DESCRIPTION OF THE INVENTION

[0016] Referring to Fig. 2 illustrating a relationship between the amount of exposure to light and the potential on the surface of a photosensitive material, a curve α represents characteristics of a single-layer organic photosensitive material, a curve β represents characteristics of a laminated-layer organic photosensitive material and a curve γ represents characteristics of an amorphous silicon photosensitive material (their details will be described later in Examples). In all of these curves, the potentials rapidly break in the initial stage due to attenuation of light in the zone of a small amount of exposure to light but change mildly in the zone of a large amount of exposure to light so as to approach predetermined saturation values.

[0017] According to the present invention, the developing bias potential (EB) is set to be higher than a potential that corresponds to a point of intersection H where a line F approximating the zone of a large amount of exposure to light of a light attenuation characteristics curve α (β or γ) of a photosensitive material intersects a line G approximating the zone of a small amount of exposure to light in Fig. 3 where the light attenuation characteristics curve of Fig. 2 are plotted on a logarithmic scale (though the point of intersection H is shown concerning the curve α only to simplify the drawing, it should be noted that the same also holds true even for other curves).

[0018] The line F approximating the zone of a large amount of exposure to light represents high sensitivity characteristics in the zone of a small amount of exposure to light of the photosensitive material and the line G approximating the zone of a small amount of exposure to light represents low sensitivity characteristics in the zone of a large amount of exposure to light of the photosensitive material. In the present invention, therefore, the developing bias potential (EB)

is set to be higher than a potential that corresponds to the point of intersection H of these two lines in order to effectively utilize high sensitivity characteristics in the zone of a small amount of exposure to light thereby to form an electrostatic latent image of a high contrast with a small amount of exposure to light or within a short exposure time.

5 [0019] The light attenuation in the photosensitive material varies as an exponential function and can be approximated by the above-mentioned formula (1) which is the sum of two exponential functions. That is, the absolute value (volts) of potential on the surface of the photosensitive material with the amount I of exposure to light (lux-sec) is measured relative to the absolute value V_0 (volts) of the initial potential on the surface of the photosensitive material, and the measured values are substituted for the formula (1) to find values of coefficients A, B, C and D. Here, however, A and C are such that their sum is 1.

10 [0020] Light attenuation characteristics (light sensitivity characteristics) of potential of the photosensitive material can be represented by values of four coefficients A, B, C and D. It can be said that the photosensitive material having a large coefficient A is highly sensitive and that the photosensitive material having a large coefficient C loses the electric charge at a small rate when it is exposed to large amounts of light.

15 [0021] In the photosensitive material used in the present invention, it is desired that the coefficients A and C are numbers of from 0.7 to less than 1 and from greater than 0 to 0.3, respectively, under the condition that their sum is 1, that the coefficient B is from 0.1 to 1.5 lux-sec⁻¹ and that the coefficient D is less than the coefficient B and is from 0.01 to 0.2 lux-sec⁻¹. Among these coefficients, A and C affect seriously. In a single-layer organic photosensitive material, the coefficient A has a value of from 0.75 to 0.85 and in a laminated-layer organic photosensitive material, the coefficient A has a value of from 0.9 to 0.80. In an amorphous silicon photosensitive material, the coefficient A has a value of from 20 0.95 to 0.85.

[0022] The present invention can be applied particularly advantageously to a photosensitive material which loses the electric charge mildly at around a half amount of exposure to light, i.e., to an organic photosensitive material in which the charge-generating agent is dispersed and, particularly, to a single-dispersion-layer photosensitive material in which the charge-generating substance is dispersed in a resin medium which include a charge-transporting substance and, 25 most desirably, to a single-dispersion-layer photosensitive material of the positively charged type.

[0023] The suitable developing bias potential (EB) could be found by a graphic solution from a light attenuation characteristics curve of the photosensitive material shown in Fig. 2 but is found from a point of intersection H of a line F approximating the zone of a large amount of exposure to light and a line G approximating the zone of a small amount of exposure to light based upon the plotting of logarithmic values of the surface potential and the amount of exposure to light shown in Fig. 3. The method of Fig. 3 makes it possible to find the suitable developing bias potential (EB) more 30 correctly.

[0024] In general, the developing bias potential (EB) is given by the gradient of the line F approximating the zone of a small amount of exposure to light and the gradient of the line G approximating the zone of a large amount of exposure to light.

35 [0025] On the side of the zone of a small amount of exposure to light, there are employed a surface potential of 0.9 V_{0A} , the amount of exposure to light corresponding thereto, a surface potential of 0.7 V_{0A} and the amount of exposure to light corresponding thereto. This is because they give a good curve F approximating the zone of a small amount of exposure to light. On the side of the zone of a large amount of exposure to light, similarly, there are employed a surface potential of 0.9 V_{0C} , the amount of exposure to light corresponding thereto, a surface potential of 0.8 V_{0C} and the amount of exposure to light corresponding thereto. This is because they give a good curve G approximating the zone 40 of a large amount of exposure to light.

[0026] According to the present invention, furthermore, the amount of exposure to light in a bright portion is so set that the residual potential (ER) at the bright portion is lower than the bias potential (EB). As pointed out already, setting the developing bias potential (EB) to a large value means that the residual potential (ER) at the bright portion can be set to a large value during the exposure to light which, then, means that the amount of exposure to light or the exposure 45 time can be decreased.

[0027] In practice, referring to Examples appearing later, when the developing bias potential is set to lie within a range contemplated by the invention, there is obtained an image of a high density with a decreased amount of exposure to light suppressing the fogging density compared with when the developing bias potential is set to a value outside the 50 range of the present invention, which is quite an unexpected fact.

[0028] Therefore, the present invention requires a source of light of a small output and a cooling fan of a small size for removing the heat from the source of light, making it possible to decrease the cost of the apparatus and the power cost. Moreover, since the organic photosensitive material needs be irradiated with a small amount of light, the photosensitive material is less deteriorated with light, which is an advantage. When a customary source of light is used, 55 furthermore, the step of exposure to light is accomplished within short periods of time, making it possible to greatly increase the copying speed, printing speed of a facsimile and printing speed of a laser printer.

[0029] How low the residual potential be set is so determined as described below. That is, the amount of exposure to light at the bright portion is so determined that the residual potential (ER) at the bright portion satisfies the above-mentioned

formula (2) though it may vary depending upon a light attenuation characteristics curve of potential of the photosensitive material, applied bias potential, and developing sensitivity characteristics of the photosensitive material and the developing agent.

5 **[0030]** In general, when the substrate of the photosensitive material is grounded and a voltage (bias voltage) of a polarity same as the polarity of the charge of the toner is applied to the developing sleeve which supports the toner without charging the photosensitive layer, the optical density of the transferred toner on the photosensitive layer increases with an increase in the applied voltage. Even when the voltage is brought to zero, however, transfer of the toner takes place, and the toner concentration on the photosensitive layer does not become zero. In Fig. 4 are plotted a relationship (developing sensitivity characteristics) between the voltage applied to the developing sleeve and the optical density (I.D.) of the toner layer transferred (developed) onto the non-charged photosensitive layer for a combination of the negatively charged toner and the non-charged photosensitive layer. According to the diagramed results, the toner is developed even when no voltage is applied. To prevent the toner from being developed, it will be understood that a voltage (generally, a voltage of the same polarity as the photosensitive material) of a polarity opposite to the polarity of charge of the toner must be applied to the developing sleeve.

10 **[0031]** If a potential at which the fogging density becomes substantially zero is denoted as EDO concerning developing sensitivity characteristics of a combination of a particular photosensitive material and a particular developing agent, it is theoretically required that a difference between the bias potential EB and the residual potential ER of the exposed bright portion must be greater than ED0. Under practical developing conditions, however, fogging in the white portion can be eliminated if the difference is not smaller than 0.4 times of ED0.

15 **[0032]** Referring to the above-mentioned formula (2), when n is smaller than 0.4, fogging in the white portion increases, which is not desirable. When n is greater than 2.5, on the other hand, no particularly distinguished merit is obtained in regard to preventing fogging but resulting in an increase in the amount of exposure to light, which is not desirable, either.

20 [Outline of Electrophotographic Method]

25 **[0033]** Referring to Fig. 5 illustrating an apparatus (copying machine) used for the electrophotographic method of the present invention, a photosensitive layer and, particularly, an organic photosensitive layer 2 is provided on the surface of a metal drum 1 that is rotated.

30 **[0034]** Along the periphery of the drum are provided a corona charger 3 for main charging, a lamp 4, a mechanism for exposure to image-bearing light comprising a document-support transparent plate 5 and an optical system 6, a developing mechanism 8 having a developing agent 7, a corona charger 9 for transferring the toner, a corona charger 10 for separating the paper, a lamp 11 for removing electric charge, and a cleaning mechanism 12 in the order mentioned.

[0035] Briefly described below are the steps for forming image by the electrophotographic apparatus.

35 **[0036]** First, the photosensitive layer 2 is electrically charged by the corona charger 3 to a predetermined polarity. Next, the document 13 to be copied is illuminated with the lamp 4, so that the photosensitive layer 2 is exposed to light image of the document via the optical system 6 thereby to form an electrostatic latent image corresponding to the document image. The electrostatic latent image is visualized through the developing mechanism 8 to form a toner image. A transfer paper 14 is so fed as to come into contact with the surface of the drum at a position of the charger 9 for transferring the toner, and the back surface of the transfer paper 14 is subjected to the corona charging of a polarity same as that of the electrostatic image to transfer the toner image onto the transfer paper 14. The transfer paper 14 onto which the toner image is transferred is electrostatically peeled off the drum as the electric charge is removed by the corona charger 10 for separation and is sent to a processing zone such as fixing zone (not shown). Residual charge is removed from the photosensitive layer 2 after the toner has been transferred as it is exposed over its whole surface to the light from the lamp 11 for removing electric charge and, then, the residual toner is removed by the cleaning mechanism 12.

40 **[0037]** The developing device 8 which is shown on an enlarged scale in Fig. 6 includes a toner feed hopper 21, a toner feed roller 22, a developing agent stirrer roller 23, and a cylindrical developing agent conveyer sleeve 25 containing a magnet 24 in which N-pole and S-pole are alternately arranged. On the side of feeding the developing agent, there is provided a blade 26 for trimming the ear of the magnetic brush on the sleeve to a predetermined length.

45 **[0038]** In the developing device, at least either the magnet 24 or the sleeve 25 is allowed to rotate, and the direction of conveying the magnetic brush may be either the same as or opposite to the drum 1 at a position where it is in contact therewith.

50 **[0039]** The sleeve 25 is made of a nonmagnetic electrically conducting material such as aluminum, and a bias power source 27 is connected to the sleeve 25 so that a predetermined developing bias potential is applied to the developing sleeve 25, the developing bias potential having a polarity same as the polarity of the electric charge on the surface of the photosensitive material.

55 **[0040]** In the device shown in Fig. 4, the exposure to image-bearing light is effected by a mechanism for exposure to image-bearing light constituted by the lamp 4, document-support transparent plate 5 and optical system 6. However,

the exposure to image-bearing light can also be effected using an exposure device based upon a widely known laser beam or an array of light-emitting diodes (LEDs).

[0041] According to the present invention, developing is effected by setting the developing bias potential (EB) applied across the sleeve 25 and the photosensitive drum 1 to be greater than a potential that corresponds to a point of intersection H (Fig. 3) of a line approximating the zone of a large amount of exposure to light in the light attenuation characteristics curve of the photosensitive layer 2 and the line approximating the zone of a small amount of exposure to light.

[0042] The amount of exposure to light at the bright portion is so set that the residual potential (ER) at the bright portion becomes smaller than the bias potential (EB) and, more preferably, that the value n in the formula (2) is from 0.4 to 2.5 and, particularly, from 0.5 to 2.0.

[Photosensitive Material]

[0043] The photosensitive material used in the present invention may be either an organic photosensitive material or an inorganic photosensitive material provided it satisfies the above-mentioned formula (1).

[0044] Great effects are exhibited by an organic photosensitive material and, particularly, by an organic photosensitive material in which a charge-generating agent is dispersed in a resin medium and, particularly, distinguished effects are exhibited by a single-dispersion-layer photosensitive material which contains a charge-transporting agent and, particularly, a positive hole-transporting agent and a charge-generating agent in a resin medium.

[0045] It is allowable to use the photosensitive material of the present invention as a matter of course, as well as to use a laminated-layer photosensitive material of a charge-transporting layer containing a charge-transporting agent and a charge-generating layer containing a charge-generating agent. In this case, the charge-generating layer (CGL) and the charge-transporting layer (CTL) may be laminated in this order or in an opposite order.

[0046] Examples of the charge-generating agent include selenium, selenium-tellurium, amorphous silicon, pyrylium salt, azo pigment, dis-azo pigment, tris-azo pigment, anthanthrone pigment, phthalocyanine pigment, indigo pigment, threne pigment, toluidine pigment, pyrazoline pigment, pyranthrone pigment, perylene pigment and quinacridone pigment, which may be used in a single kind or in a mixture of two or more kinds to exhibit an absorption wavelength over a desired region.

[0047] Among them, phthalocyanine pigment, perylene pigment and dis-azo pigment are preferred.

[0048] A variety of resins can be used as resin media for dispersing the charge-generating agent. Examples include olefin polymers such as styrene polymer, acrylic polymer, styrene-acrylic polymer, ethylene-vinyl acetate copolymer, polypropylene, ionomer, etc. and polyvinyl chloride, vinyl chloride-vinyl acetate copolymer, polyester, alkyd resin, polyamide, polyurethane, epoxy resin, polycarbonate, polyarylate, polysulfone, dialylphthalate resin, silicone resin, ketone resin, polyvinyl butyral resin, polyether resin and phenolic resin, and photocurable resins such as epoxyacrylate. These binder resins may be used in a single kind or in a mixture of two or more kinds. Preferred resins are styrene polymer, acrylic polymer, styrene-acrylic polymer, polyester, alkyd resin, polycarbonate, polyarylate, etc.

[0049] A particularly preferred resin is a polycarbonate derived from a phosgene and bisphenols represented by the following general formula (8),

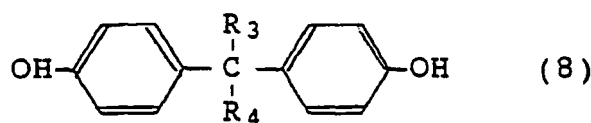

wherein R3 and R4 are hydrogen atoms or lower alkyl groups, and R3 and R4, being coupled together, may form a cyclic ring such as a cyclohexane ring together with carbon atoms bonded thereto.

[0050] The charge transporting agent (CTM) may have electron-transporting property or positive hole-transporting property. Or, they may be used in combination. Suitable examples include electron attractive substances such as paradiphenoquinone derivatives, benzoquinone derivatives, naphthoquinone derivatives, tetracyanoethylene, tetracyanoquinodimethane, chloroanil, bromoanil, 2,4,7-trinitro-9-fluorenone, 2,4,5,7-tetranitro-9-fluorenone, 2,4,7-trinitro-9-dicyanomethylene fluorenone, 2,4,5,7-tetranitroxanthone, and 2,4,8-trinitrothioxanthone, as well as high molecules derived from those electron attractive substances.

[0051] Among them, paradiphenoquinone derivatives and, particularly, asymmetrical paradiphenoquinone derivatives are excellent in solubility and in electron-transporting property.

[0052] Paradiphenoquinone derivatives represented by the following general formula (9) are used,

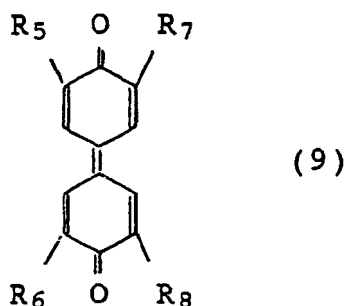

wherein R5, R6, R7 and R8 are hydrogen atoms, alkyl groups, cycloalkyl groups, aryl groups, aralkyl groups or alkoxy groups.

[0053] It is desired that the substituents R5, R6, R7 and R8 exist in asymmetrical forms. Among the substituents R5, R6, R7 and R8, it is desired that two of them are lower alkyl groups, and other two are branched chain alkyl groups, cycloalkyl groups, aryl groups or aralkyl groups.

[0054] Though there is no particular limitation, suitable examples include 3,5-dimethyl-3',5'-di-t-butylidiphenylquinone, 3,5-dimethoxy-3',5'-di-t-butylidiphenylquinone, 3,3'-dimethyl-5,5'-di-t-butylidiphenylquinone, 3,5'-dimethyl-3',5'-di-t-butylidiphenylquinone, 3,5,3',5'-tetramethyldiphenylquinone, 2,6,2',6'-tetra-t-butylidiphenylquinone, 3,5,3',5'-tetraphenylidiphenylquinone, 3,5,3',5'-tetracyclohexyldiphenylquinone and the like. These diphenylquinone derivatives have low molecular symmetry, exhibit small mutual action among the molecules and are excellent in solubility.

[0055] As the positive hole-transporting substances, the following substances have been known. Among them, those compounds having excellent solubility and positive hole-transporting property are used:

pyrene;
 N-ethylcarbazole;
 N-isopropylcarbazole;
 N-methyl-N-phenylhydrazino-3-methylidene-9-carbazole;
 N,N-diphenylhydrazino-3-methylidene-9-ethylcarbazole;
 N,N-diphenylhydrazino-3-methylidene-10-ethylphenothiazine;
 N,N-diphenylhydrazino-3-methylidene-10-ethylphenoxazine;
 p-diethylaminobenzaldehyde-N,N-diphenylhydrazine;
 p-diethylaminobenzaldehyde- α -naphthyl-N-phenylhydrazine;
 p-pyrrolidinobenzaldehyde-N,N-diphenylhydrazine;
 1,3,3-trimethylindolenine- ω -aldehyde-N,N-diphenylhydrazine;
 p-diethylbenzaldehyde-3-methylbenzthiazolinone-2-hydrazine;
 and salts of those hydrazone;
 2,5-bis(p-diethylaminophenyl)-1,3,4-oxadiazole;
 1-phenyl-3-(p-diethylaminostyryl)-5-(p-diethylaminophenyl)pyrazoline;
 1-[quinonyl(2)]-3-(p-diethylaminostyryl)-5-(p-diethylaminophenyl)pyrazoline;
 1-[pyridyl(2)]-3-(p-diethylaminostyryl)-5-(p-diethylaminophenyl)pyrazoline;
 1-[6-methoxy-pyridyl(2)]-3-(p-diethylaminostyryl)-5-(p-diethylaminophenyl)pyrazoline;
 1-[pyridyl(3)]-3-(p-diethylaminostyryl)-5-(p-diethylaminophenyl)pyrazoline;
 1-[lepidyl(3)]-3-(p-diethylaminostyryl)-5-(p-diethylaminophenyl)pyrazoline;
 1-[pyridyl(2)]-3-(p-diethylaminostyryl)-4-methyl-5-(p-diethylaminophenyl)pyrazoline;
 1-[pyridyl(2)]-3-(α -methyl-p-diethylaminostyryl)-3-(p-diethylaminophenyl)pyrazoline;
 1-phenyl-3-(p-diethylaminostyryl)-4-methyl-5-(p-diethylaminophenyl)pyrazoline; and spiropyrazoline;

oxazole compounds such as:

2-(p-diethylaminostyryl)-3-diethylaminobenzoxazole; and
 2-(p-diethylaminophenyl)-4-(p-dimethylaminophenyl)-5-(2-chlorophenyl)oxazole; thiazole compounds such as:
 2-(p-diethylaminostyryl)-6-diethylaminobenzothiazole;

triarylmethane compounds such as:

bis(4-diethylamino-2-methylphenyl)phenylmethane;

polyarylanes such as:

- 5 1,1-bis(4-N,N-diethylamino-2-methylphenyl)heptane;
1,1,2,2-tetrakis(4-N,N-dimethylamino-2-methylphenyl)ethane;

benzidine compounds such as:

- 10 N,N'-diphenyl-N,N'-bis(methylphenyl)benzidine;
N,N'-diphenyl-N,N'-bis(ethylphenyl)benzidine;
N,N'-diphenyl-N,N'-bis(propylphenyl)benzidine;
N,N'-diphenyl-N,N'-bis(butylphenyl)benzidine;
N,N'-bis(isopropylphenyl)benzidine;
15 N,N'-diphenyl-N,N'-bis(secondary butylphenyl)benzidine;
N,N'-diphenyl-N,N'-bis(tertiary butylphenyl)benzidine;
N,N'-diphenyl-N,N'-bis(2,4-dimethylphenyl)benzidine; and
N,N'-diphenyl-N,N'-bis(chlorophenyl)benzidine; and
triphenylamine;
20 poly-N-vinylcarbazole;
polyvinyl pyrene;
polyvinyl anthracene;
polyvinyl acridine;
poly-9-vinylphenyl anthracene;
25 pyrene-formaldehyde resin; and
ethylcarbazole formaldehyde resin.

[0056] Among them, the benzidine transporting agents and, particularly, the transporting agents represented by the general formula (10),

30

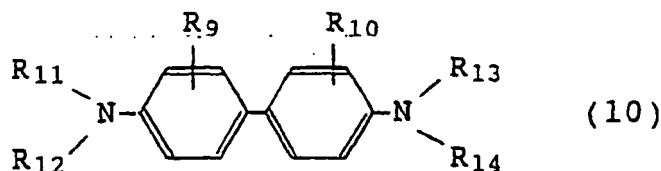

35

40 wherein R9 and R10 are lower alkyl groups such as methyl groups or ethyl groups, R₁₁, R₁₂, R₁₃ and R₁₄ are alkyl groups, cycloalkyl groups, aryl groups, alkaryl groups or aralkyl groups with not more than 18 carbon atoms, and the carbazole hydrazone transporting agents and, particularly, those transporting agents represented by the general formula (11)

45

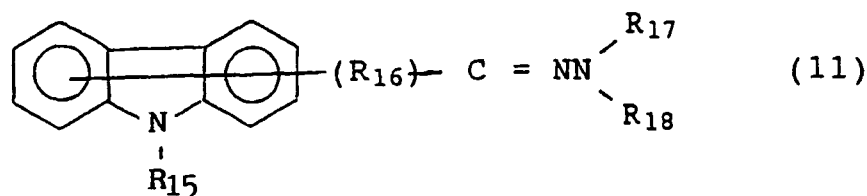

50

55 wherein R₁₅ is a hydrogen atom, alkyl group or acyl group, R₁₆ is a divalent organic group such as alkylene group, and R₁₇ and R₁₈ are each alkyl group, cycloalkyl group, aryl group, alkaryl group or aralkyl group with not more than 18 carbon atoms,

are preferred owing to their solubility and positive hole-transporting property.

[0057] In the single-dispersion-layer photosensitive material used in the present invention, it is desired that the

charge-generating agent (CGM) is contained in the photosensitive layer in an amount of from 1 to 7% by weight and, particularly, from 2 to 5% by weight per the solid component and the charge-transporting agent (CTM) is contained in the photosensitive layer in an amount of from 20 to 70% by weight and, particularly, from 25 to 60% by weight per the solid component.

5 **[0058]** From the standpoint of sensitivity and broadening the application such as enabling the reversal development, furthermore, it is desired that the electron-transporting agent (ET) and the positive hole-transporting agent (HT) are used in combination. In this case, it is most desired that weight ratio of ET:HT is from 10:1 to 1:10 and, particularly, from 1:5 to 1:1.

10 **[0059]** The composition for forming the photosensitive material used in the present invention may be blended with a variety of blending agents that have been widely known within ranges in which they do not adversely affect the electro-photographic characteristics, such as anti-oxidizing agent, radical trapping agent, singlet quencher, UV-absorbing agent, softening agent, surface reforming agent, defoaming agent, filler, viscosity-imparting agent, dispersion stabilizer, wax, acceptor, donor and the like.

15 **[0060]** When a steric hindrance phenolic anti-oxidizing agent is blended in an amount of from 0.1 to 50% by weight per the whole solid component, furthermore, it is allowed to drastically improve the durability of the photosensitive layer without adversely affecting the electrophotographic properties.

20 **[0061]** As the electrically conducting substrate for providing a photosensitive layer, there can be used a variety of materials having electrically conducting property such as single metals like aluminum, copper, tin, platinum, gold, silver, vanadium, molybdenum, chromium, cadmium, titanium, nickel, indium, stainless steel, brass, plastic materials on which the above-mentioned metals are vaporized or laminated, and glasses coated with aluminum iodide, tin oxide or indium oxide.

[0062] The shape of the photosensitive material that is used is not limited to only those of the drum type but may be those of the type of belt or sheet.

25 **[0063]** In the single-dispersion-layer photosensitive material of the present invention, it may be employed an aluminum blank tube, preferably an alumite-treated tube having 1 to 50 μm in thickness of alumite layer on the surface, since there does not develop any interference fringe.

[0064] The single-dispersion-layer photosensitive material is obtained by blending the charge-generating material, charge-transporting material and binder resin according to a customary method using, for example, roll mill, ball mill, Attritor, paint shaker or an ultrasonic dispersing device, and applying them relying upon a customary application means, followed by drying.

30 **[0065]** Though there is no particular limitation, the photosensitive layer has a thickness of usually from 10 to 40 μm and, particularly, from 20 to 35 μm .

35 **[0066]** A variety of organic solvents can be used for obtaining a coating solution. Examples include alcohols such as methanol, ethanol, isopropanol, butanol, etc., aliphatic hydrocarbons such as n-hexane, octane, cyclohexane, etc., aromatic hydrocarbons such as benzene, toluene, xylene, etc., halogenated hydrocarbons such as dichloromethane, dichloroethane, carbon tetrachloride, chlorobenzene, etc., ethers such as dimethyl ether, diethyl ether, tetrahydrofuran, ethylene glycol dimethyl ether, diethylene glycol dimethyl ether, etc., ketones such as acetone, methyl ethyl ketone, cyclohexanone, etc., esters such as ethyl acetate, methyl acetate, etc., as well as dimethyl formamide, dimethyl sulfoxide, etc., which may be used in one kind or being mixed in two or more kinds. The coating solution should contain a solid component at a concentration of, usually, from 5 to 50%.

40 **[0067]** In the case of the laminated-layer photosensitive material, it is desired that the charge-generating agent (CGM) is contained in an amount of from 30 to 90% by weight and, particularly, from 40 to 80% by weight per the solid component in the charge-generating layer (CGL). It is further desired that the charge-transporting agent (CTM) is contained in an amount of from 20 to 70% by weight and, particularly, from 30 to 60% by weight per the solid component in the charge-transporting layer (CTL).

45 **[0068]** The components in the coated layers comply with the components in the single dispersion layer.

[0069] In the case of the substrate/CGL/CTL photosensitive material, it is desired that CGL has a thickness which, usually, lies within a range of from 0.1 to 0.5 μm and CTL has a thickness which lies within a range of from 5 to 40 μm and, particularly, from 10 to 25 μm .

50 **[0070]** In the case of the substrate/CTL/CGL photosensitive material, it is desired that CTL has a thickness of from 5 to 40 μm and, particularly, from 10 to 25 μm , and CGL has a thickness of from 0.1 to 0.5 μm .

[0071] It is further allowable to provide a widely known protecting layer on the CGL.

[0072] The present invention can be applied even to an inorganic photosensitive material provided it has surface potential vs. amount of exposure to light characteristics represented by the formula (1). Such an inorganic photosensitive material can be exemplified by an amorphous silicon photosensitive material.

55 **[0073]** Any widely known amorphous silicon (a-Si) photosensitive layer can be used, such as the one precipitated on an electrically conducting substrate such as an aluminum blank tube by the decomposition of a silane gas with a plasma. This amorphous silicon photosensitive layer may be doped with hydrogen or halogen and, further, with an element of the Group III or the Group V of periodic table, such as boron or phosphorus.

[0074] From the standpoint of resistance against oxidation, the surface layer of the amorphous silicon photosensitive material should exist in the form of a-Si:C. Most desirably, therefore, it is recommended to use a three-layer structure consisting of an a-Si:C surface layer, an a-Si layer and an a-Si:C, B or O barrier layer. It is desired that the amorphous silicon photosensitive layer has a total thickness of from 20 to 100 μm and, particularly, from 25 to 90 μm , and the SiC surface layer has a thickness of from 0.2 to 1 μm and, particularly, from 0.3 to 0.8 μm . When the lower barrier layer is provided, its thickness may be from 0.5 to 5 μm and, particularly, from 1 to 3 μm .

[0075] A representative amorphous silicon photosensitive material has such physical values as a dark electric conductivity of $\leq 10^{-12} \Omega^{-1} \cdot \text{cm}^{-1}$, activation energy of $< 0.85 \text{ eV}$, a photoelectric conductivity of $> 10^{-7} \Omega^{-1} \cdot \text{cm}^{-1}$, and an optical band gap of from 1.7 to 1.9 eV. Moreover, the amount of bonded hydrogen is from 10 to 20 atomic %, and the dielectric constant of the film is from 11.5 to 12.5.

[Electrophotographic Process]

[0076] The photosensitive material may be mainly charged by corona charging using Corotron, Scorotron or the like, or by a widely known contact-type charging device using a charging brush, charging roll or charging blade. In general, it is desired that the main charging is effected such that the saturation charging potential (VS) is from 400 to 1500 V and, particularly, from 600 to 1200 V. In the case of the corona charging, therefore, it is desired that a voltage of from 4 to 10 KV is applied to the charger. In the contact-type charging, on the other hand, it is desired that a voltage which is from 3 to 6 times as great as the charge starting voltage of the photosensitive material is applied to the charging device.

[0077] In the present invention, the photosensitive material after it is mainly charged is exposed to image-bearing light to form an electrostatic latent image. The source of light for exposure to light may be any source of visible light such as halogen lamp, fluorescent lamp, cold cathode tube, or red or green neon lamp. It is, however, also allowable to use a source of hypochromic light such as red, yellow or green LED. It is further allowed to use a source of laser beam such as semiconductor laser beam.

[0078] In this case, the amount of exposure to light (IB) at a bright portion is such that the residual potential (ER) at the bright portion is lower than the bias potential (EB) and is, more preferably, such that the residual potential (ER) at the bright portion lies within a range defined by the formula (7).

[0079] The developing is effected by applying a developing bias potential (EB) and the developing bias potential (EB) having the same polarity as the potential of the photosensitive material and being higher than a potential that corresponds to the point of intersection H (Fig. 3) of a line F approximating the zone of a large amount of exposure to light and a line G approximating the zone of a small amount of exposure to light in the light attenuation characteristics curve of the photosensitive material.

[0080] It is desired that the developing is effected by the magnetic brush developing. For this purpose, a one-component or a two-component magnetic developing agent is used. This is because, in the present invention, the developing is effected in a state of a potential contrast which is rather lower than that of the conventional method. In this respect, magnetic properties of the toner seriously affect the setting of threshold developing value without fogging.

[0081] The one-component magnetic developing agent used in the present invention contains a magnetic powder in the toner, and the two-component magnetic developing agent comprises a mixture of a toner and a magnetic carrier.

[0082] To obtain a high density image by developing in a state of low potential contrast without generating fogging, it is desired that the amount of electric charge possessed by the toner is maintained at a relatively low level. In general, it is desired that the amount of electric charge of the toner is maintained within a range of from 10 to 30 $\mu\text{C/g}$ and, particularly, from 15 to 25 $\mu\text{C/g}$.

[0083] As the binder resin which is a toner component, there can be used a thermoplastic resin, an uncured thermosetting resin, or a thermosetting resin of an initial condensation product. Suitable examples include, in order of suitability, vinyl aromatic resin such as polystyrene, styrene-acrylic copolymer resin, acrylic resin, polyvinyl acetal resin, polyester resin, epoxy resin, phenol resin, petroleum resin, olefin resin and the like.

[0084] To adjust the toner charge to lie within the above-mentioned range, there are used, as required, a charge control agent like an oil-soluble dye such as Nigrosine base (CI 50415), oil black (CI 26150), spiron black or the like, or metal complex dye, metal salt of naphthenic acid, metal soap of fatty acid, and salt of resin acid.

[0085] It is further allowable to impart a minimum degree of charge control action necessary for the developing by utilizing the charge control action possessed by the resin. That is, there can be used a copolymerized resin or a resin composition having anionic or cationic polar group as part of the fixing resin medium in the toner that is used. As the cationic polar groups, there can be exemplified basic nitrogen-containing groups such as primary, secondary or tertiary amino group, quaternary ammonium group, amide group, imino group, imido group, hydrazino group, guanidino group and amidino group. As the anionic groups, there can be exemplified carboxyl group, sulfone group, phosphone group, etc. As the above-mentioned resins, furthermore, there can be exemplified resins obtained by polymerizing a cationic or anionic polar group-containing monomer with other monomers or resins by such means as random copolymerization, block copolymerization or graft copolymerization.

[0086] As the coloring agent to be contained in the resin, there can be used the following inorganic or organic pigments and dyes in a single kind or in a combination of two or more kinds, though there is no particular limitation: carbon black such as furnace black or channel black; iron black such as tri-iron tetroxide; rutile or anatase type titanium dioxide; Phthalocyanine Blue; Phthalocyanine Green, cadmium yellow, molybdenum orange; Pyrazolone Red; Fast Violet B; and the like.

[0087] The above-mentioned coloring agent is used in an amount of from 5 to 20 parts by weight and, particularly, 10 to 15 parts by weight per 100 parts by weight of a fixing resin medium.

[0088] The above-mentioned resin may contain, as a release agent for thermal fixing, a variety of waxes and low molecular olefin resins. Here, the olefin resins may have a number average molecular weight (Mn) of from 1000 to 10000 and, particularly, from 2000 to 6000. As the olefin resin, there can be used polypropylene, polyethylene or propylene-ethylene copolymer. Among them, polypropylene is particularly preferred.

[0089] As the magnetic materials to be added to the toner or to be used as a magnetic carrier, there can be used widely known magnetic materials such as tri-iron tetroxide (Fe_3O_4), iron sesquioxide ($\gamma\text{-Fe}_2\text{O}_3$), zinc iron oxide (ZnFe_2O_4), yttrium iron oxide ($\text{Y}_3\text{Fe}_5\text{O}_{12}$), cadmium iron oxide (CdFe_2O_4), gadolinium iron oxide ($\text{Gd}_3\text{Fe}_5\text{O}_{12}$), copper ion oxide (CuFe_2O_4), lead iron oxide ($\text{PbFe}_{12}\text{O}_{19}$), nickel iron oxide (NiFe_2O_4), neodymium iron oxide (NdFeO_3), barium iron oxide ($\text{BaFe}_{12}\text{O}_{19}$), magnesium iron oxide (MgFe_2O_4), manganese iron oxide (MnFe_2O_4), lanthanum iron oxide (LaFeO_3), iron powder (Fe), cobalt powder (Co), nickel powder (Ni) and the like. It is desired that these magnetic materials generally have saturation magnetization of from 30 to 70 emu/g.

[0090] In the case of the one-component toner, it is desired that the magnetic fine powder is contained in an amount of from 20 to 50% by weight relative to the toner.

[0091] As the magnetic carrier, on the other hand, there can be used tri-iron tetroxide, ferrite or iron powder that has been widely known. The magnetic carrier of the ferrite type is particularly suited. It is desired that the magnetic carrier has an average particle diameter of from 60 to 150 μm , and the magnetic carrier having a particle diameter of not larger than 44 μm occupies 3 to 15% by weight. The magnetic carrier, usually, has a density of from 3.50 to 6.50 g/cm^3 and, particularly, from 4.00 to 5.50 g/cm^3 though it may vary depending upon the carrier concentration C/D.

[0092] It is desired that the saturation magnetization of the carrier is from 30 to 70 emu/g and, particularly, from 53 to 65 emu/g. The magnetic carrier is desirably a ferrite carrier and, particularly, a spherical ferrite carrier satisfying the above-mentioned conditions. The particle size distribution satisfies the above-mentioned conditions but should desirably have a normal distribution or a distribution close thereto. The carrier that is used may not be coated or may be coated with a widely known resin such as silicone resin, acrylic resin, epoxy resin or fluorine-containing resin.

[0093] The electric resistance of the ferrite carrier varies depending upon its chemical composition but also varies depending upon its particle structure, production method, kind of coating and the thickness. In general, the volume resistivity should be from 5×10^8 to $5 \times 10^{11} \Omega\text{-cm}$ and, particularly, from 1×10^9 to $1 \times 10^{11} \Omega\text{-cm}$.

[0094] It is desired that the weight percentage of the toner T/D in the developing agent is, usually, from 3 to 8% and, particularly, from 3.5 to 7.5%. It is further desired that the developing agent as a whole has an electric resistance of from 1×10^9 to $1 \times 10^{11} \Omega\text{-cm}$ and, particularly, from 5×10^9 to $5 \times 10^{11} \Omega\text{-cm}$.

[0095] It is better to use toner particles having an average particle diameter of from 5 to 15 μm and, particularly, from 8 to 12 μm . The particles may have an irregular shape as prepared by the melt-kneading method or pulverization method, or may have a spherical shape as prepared by the dispersion or suspension polymerization method.

[0096] The toner can be produced by any known method such as pulverization-classification method, melt-granulation method, spray-granulation method or polymerization method. The pulverization-classification method, however, is generally employed.

[0097] The toner components are mixed in advance by a mixer such as Henschel's mixer and are kneaded by using a kneader such as a biaxial extruder. The kneaded composition is then cooled, pulverized and is classified to obtain a toner.

[0098] As an agent to be externally added to the toner, furthermore, use is made of magnetic fine particles and hydrophobic silica in combination from the standpoint of preventing fogging on the white paper exposed to light and improving image density.

[0099] As the magnetic fine particles, use is made of the above-mentioned magnetic fine particles having a particle diameter of from 0.1 to 0.5 μm . The magnetic powder which is particularly adapted to this purpose is a fine particulate tri-iron tetroxide (magnetite). The preferred magnetite has an ortho-octahedral shape. The magnetite particles may be treated for their surfaces with a silane coupling agent or a titanium coupling agent. The magnetite particles of which the surfaces are treated with the titanium coupling agent are desirable from the standpoint of resistance against environment.

[0100] The hydrophobic silica that is externally added is obtained by treating vapor-phase silica, i.e., by treating fine silica obtained by subjecting silicon chloride to a high-temperature (flame) hydrolysis with an organic silicon compound such as silanes like dimethyl dichlorosilane, trimethyl chlorosilane or the like, and by blocking silanol on the surface with organosilane.

[0101] To peel thin deteriorated layer on the surface of the photosensitive material, furthermore, a toner to which an abrasive or a polishing material is externally added can be used for the developing agent of any type.

[0102] Any known abrasive or polishing material can be used having an average particle diameter of from 0.1 to 5 μm and, particularly, from 0.15 to 1 μm . It is desired that these abrasive or polishing material usually has a Mohs' hardness of from 5 to 10.

[0103] Though there is no particular limitation, preferred examples of the abrasive or the polishing material include oxide ceramics such as alumina (Al_2O_3), zirconia (ZrO_2), mullite ($3\text{Al}_2\text{O}_3 \cdot 2\text{SiO}_2$), cordierite ($2\text{MgO}/2\text{Al}_2\text{O}_3/5\text{SiO}_2$), titania (TiO_2), steatite ($\text{MgO}_2 \cdot \text{SiO}_2$), silica, and silica alumina; carbide ceramics such as silicon carbide (SiC), tungsten carbide (WC), and zirconium carbide (ZrC); nitride ceramics such as boron nitride (BN), titanium nitride (TiN), and silicon nitride (Si_3N_4); boride ceramics such as zirconium boride (ZrB_2) and titanium boride (TiB_2); silicate ceramics such as tungsten silicate (WSi_2) and molybdenum silicate (MoSi_2); as well as diamond, corundum, chromium oxide, cerium oxide, and the like.

[0104] The amount of the abrasive or the polishing material added to the toner varies depending upon the kind of the abrasive or the polishing material and cannot be definitely determined. Generally, however, the amount of addition may be selected over a range of from 0.1 to 10% by weight and, particularly, from 0.5 to 5% by weight with respect to the toner, so that optimum scraping amount is obtained. That is, relationships are found between the amount of the toner added and the scraping amount for the abrasives or the polishing materials and the amount of blending the abrasive or the polishing material may be so determined that an optimum scraping amount (oxidation degree on the surface of the photosensitive material) is obtained.

[0105] In the electrophotographic method of the present invention, the toner image is transferred, the paper is separated and the cleaning is effected by using known means under known conditions.

EXAMPLES

[0106] The present invention will be described by way of the following Examples.

[0107] The photosensitive material used in Examples was prepared as described below.

Preparation of the Single-Layer Photosensitive Material (Photosensitive Material α) for Electrophotography:

[0108] The following composition for a photosensitive layer was mixed and dispersed in a ball mill for 50 hours to prepare a coating solution for forming a single-layer photosensitive layer. The obtained coating solution was immersion-applied to the surface of an aluminum cylinder having an outer diameter of 78 mm which is an electrically conducting base material, and was dried with the hot air heated at 100 $^\circ\text{C}$ for 60 minutes to form a single-layer photosensitive material having a thickness of 25 μm to obtain a positively charged photosensitive material for electrophotography.

Bisazo dye (following formula 12)	10 parts by weight
N,N,N',N'-tetrakis(3-methylphenyl)-m-phenylene diamine	100 parts by weight
3,5,3',5'-tetraphenyldiphenone	50 parts by weight
Polycarbonate resin	100 parts by weight
Dichloromethane	800 parts by weight

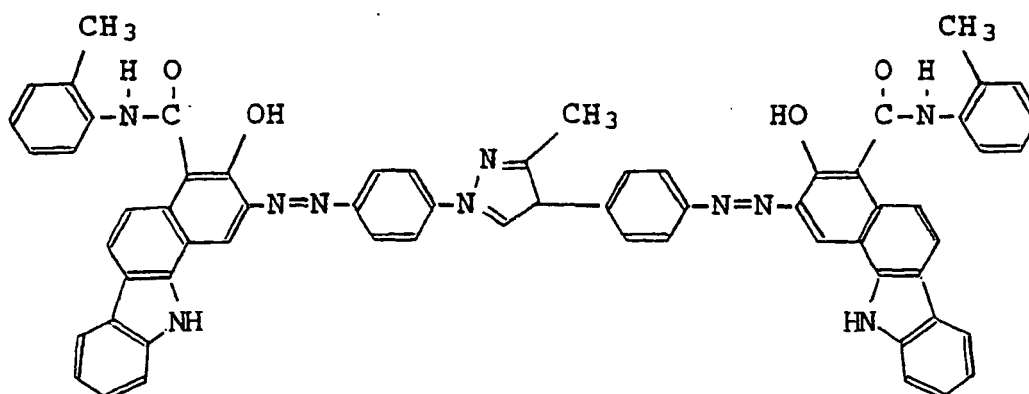

(12)

Preparation of a Laminated-Layer Photosensitive Material (Photosensitive Material β) for Electrophotography:

(1) Preparation of a charge-generating layer

5 **[0109]** The following composition for a photosensitive layer was mixed and dispersed in a ball mill for 50 hours to prepare a coating solution for generating electric charge. The obtained coating solution was immersion-applied to the surface of an aluminum cylinder having an outer diameter of 78 mm which is an electrically conducting base material, and was dried with the hot air heated at 100 °C for 60 minutes to form a charge-generating layer having a thickness of 0.5 μm .

10	Bisazo dye (above-mentioned formula 12)	2 parts by weight
	Polyvinyl butyral resin	1 part by weight
	Dichloromethane	120 parts by weight

15 (2) Preparation of a charge-transporting layer

20 **[0110]** The following composition for a photosensitive layer was mixed and dispersed in a ball mill for 24 hours to prepare a coating solution for transporting electric charge. The obtained coating solution was immersion-applied onto the above-mentioned charge-generating layer and was dried with the hot air heated at 90 °C for 60 minutes to form a charge-transporting layer having a thickness of 15 μm in order to form a laminated-layer photosensitive material.

25	N,N,N',N'-tetrakis(3-methylphenyl)-m-phenylene diamine	80 parts by weight
	Polycarbonate resin	100 parts by weight
	Dichloromethane	800 parts by weight

[0111] The developing agent used in the experiments was prepared as described below.

30	Negatively charged toner I.	
	Styrene-acrylic polymer	100 parts by weight
	Carbon black	6 parts by weight
	Chromium complex dye (charge control agent)	1 part by weight
	Low molecular polypropylene (release agent)	2 parts by weight

35 **[0112]** The above-mentioned components were melt-kneaded in a biaxial extruder, pulverized in a jet mill, and were subjected to the pneumatic classification using a classifier to obtain toner particles having an average particle diameter of 11 μm .

40 **[0113]** The above toner particles and the hydrophobic silica fine particles (R972 produced by Japan Aerosil Co.) were mixed and dispersed at a ratio of 0.3% by weight with respect the total amount of the toner to obtain a negatively charged toner I.

45	Negatively charged toner II.	
	Styrene-acrylic polymer	100 parts by weight
	Carbon black	6 parts by weight
	Chromium complex dye (charge control agent)	1 part by weight
	Low molecular polypropylene (release agent)	2 parts by weight

50 **[0114]** The above-mentioned components were melt-kneaded in a biaxial extruder, pulverized in a jet mill, and were subjected to the pneumatic classification using a classifier to obtain toner particles having an average particle diameter of 8 μm .

55 **[0115]** The above toner particles and the hydrophobic silica fine particles (R972 produced by Japan Aerosil Co.) were mixed and dispersed at a ratio of 0.5% by weight with respect to the total amount of the toner to obtain a negatively charged toner II.

EP 0 709 747 B1

	Positively charged toner III [for OPC]	
	Styrene-acrylic polymer	100 parts by weight
	Carbon black	9 parts by weight
5	Nigrosine dye (charge control agent)	1 part by weight
	Low molecular polypropylene (release agent)	2 parts by weight

[0116] The above-mentioned components were treated in the same manner as the negatively charged toner I to obtain toner particles having an average particle diameter of 10 μm .

10 [0117] The above toner particles and the hydrophobic silica fine particles (RA130H produced by Japan Aerosil Co.) were mixed and dispersed at a ratio of 0.3% by weight with respect to the total amount of the toner to obtain a positively charged toner C having an average particle diameter of 10 μm .

	Negatively charged toner IV [for a-Si]	
	Styrene-acrylic polymer	100 parts by weight
	Carbon black	6 parts by weight
	Chromium complex dye (charge control agent)	1 part by weight
	Low molecular polypropylene (release agent)	2 parts by weight

15 [0118] The above-mentioned components were melt-kneaded in a biaxial extruder, pulverized in a jet mill, and were subjected to the pneumatic classification using a classifier to obtain toner particles having an average particle diameter of 10 μm .

20 [0119] To the above toner particles were mixed and dispersed hydrophobic silica fine particles (R972 produced by Japan Aerosil Co.) at a ratio of 0.3% by weight and aluminum oxide (Aluminum Oxide C produced by Japan Aerosil Co.) at a ratio of 0.2% by weight with respect to the total amount of the toner to obtain a negatively charged toner (IV). Developing agent for +OPC (positively charged organic photosensitive material) and for a-Si photosensitive material.

25 [0120] The negatively charged toners I, IV were blended with a ferrite carrier having an average particle diameter of 100 μm of which the surfaces were coated with an acrylic resin and a melamine resin, and the negatively charged toner II was blended with a ferrite carrier having an average particle diameter of 80 μm with stirring to homogeneously mix them together in order to obtain a two-component developing agent having a toner concentration of 3.5%.

30 Developing agent for -OPC.

35 [0121] The positively charged toner III was blended with a ferrite carrier having an average particle size of 80 μm of which the surfaces were coated with an acrylic resin and a melamine resin with stirring to homogeneously mix them together in order to prepare a two-component developing agent having a toner concentration of 40%.

40 [0122] An amorphous silicon (a-Si) photosensitive material (photosensitive material γ) was also used in addition to the photosensitive material α (single-layer organic photosensitive material) and photosensitive material β (laminated-layer organic photosensitive material). That is, the photosensitive material having the same specifications as the a-Si photosensitive material mounted on the electrophotographic copying machine DC-6090 produced by Mita Kogyo Co. was prepared in such a size that can be mounted on a machine modified from the electrophotographic copying machine DC-4556 produced by Mita Kogyo Co.

45 [0123] Characteristics of the photosensitive material were found as described below.

[Measurement of light attenuation characteristics]

50 [0124] The above-mentioned photosensitive materials α , β and γ were mounted on the machine modified from the electrophotographic copying machine DC-4556 produced by Mita Kogyo Co. shown in Figs. 5 and 6, the surface potential at the developing positions was set to be 800 V, and the surface potential was measured while changing the amount of irradiation light.

[0125] The negatively charged laminated-layer organic photosensitive materials measured by changing the main charging, developing bias, transfer and power transformer of separator shift bias into those of the negative polarity.

[0126] The results of measurement were as shown in Table 2. The potentials are in absolute values V_0 .

55 [0127] Table 1 shows the values A to D found in compliance with the aforementioned formula (1) for the photosensitive materials α , β and γ , as well as point-of-intersection voltages (EH) found from Fig. 3.

Table 1

Photosensitive material	(α)	(β)	(γ)
Value A	0.8	0.9	0.9
Value B	0.58	0.65	1.2
Value C	0.2	0.1	0.1
Value D	0.18	0.04	0.11
EH	164	75	68

[Forming the image]

[0128] The above-mentioned photosensitive materials α , β and γ were mounted on the machine modified from the electrophotographic copying machine DC-4556 produced by Mita Kogyo Co. shown in Figs. 5 and 6. By using combinations of photosensitive material α -toner (I), photosensitive material α -toner (II), photosensitive material β -toner (III) and photosensitive material γ -toner (IV) as developing agents, images were formed while changing the developing bias potential in order to confirm developing characteristics.

[0129] By using the Munsell grey scale (manufactured by Nippon Shikiken Co.), the amount of exposure to light was so adjusted that a difference in the image density between N8.0 and N9.5 was 0.005 as measured by a reflection densitometer. ID represents image density (image density with respect to N1.5) and FD represents image fogging (difference between the density of N9.0 and density of non-transferred paper). The results were as shown in Table 2.

[Bias developing]

[0130] By using the machine modified from the electrophotographic copying machine DC-4556 produced by Mita Kogyo Co., bias potentials (fogging-preventing potentials) were found with which the fogging found from the bias developing characteristics shown in Fig. 4 became FD = 0.000 for the combinations of the photosensitive materials and the developing agents.

[0131] Experiment was conducted without applying voltage to the main charger (MC) and changing the voltage applied to the developing sleeve by using an external power source (Model 1041 manufactured by Kikusui Co.) in order to find image density relative to the voltage applied to the developing bias. The results were as shown in Table 2.

[0132] According to the results of Table 2, it is obvious that the fogging density increases and the amount of exposure to light increases when the developing bias potential (EB) is smaller than the point-of-intersection potential (EH). When the developing bias potential (EB) is set to be higher than the point-of-intersection potential (EH), however, the fogging density decreases yet maintaining a high image density, and the amount of exposure to light can be decreased.

[0133] According to the present invention, a bias potential (absolute value) applied during the developing is set to be higher than a potential (absolute value) that corresponds to an intersecting point of a line approximating the zone of a large amount of exposure to light and a curve approximating the zone of a small amount of exposure to light in the light attenuation characteristics curve of the photosensitive material, in order to entirely utilize the high-sensitivity characteristics in the zone of a small amount of exposure to light and, hence, to form image of a high density without fogging but sacrificing low-sensitivity characteristics in the zone of a large amount of exposure to light to a small degree, i.e., sacrificing a potential drop to a small degree.

[0134] Moreover, since the bias potential is set to a relatively large value, the amount of exposure to light only needs to be small and, hence, the source of light may have a small output, requiring a cooling fan of a small size for removing the heat from the source of light. This makes it possible to decrease the cost of the apparatus and the power cost. Moreover, since the organic photosensitive material needs to be irradiated with a small amount of light, the photosensitive material is less deteriorated by light, which is an advantage. Furthermore, the step of exposure to light is accomplished within a short period of time, making it possible to greatly increase the copying speed, printing speed of a facsimile and printing speed of a laser printer.

Table 2
Developing bias potential and developing fogging

	<u>Drum</u>	<u>Toner</u>	<u>Fogging- preventing potential</u>	<u>Developing bias potential</u>	<u>ID</u>	<u>FD</u>	<u>Amount of exposure to light</u>
Example 1	photosensitive material α	toner I	80	250	1.48	0.002	7.0
Example 2	photosensitive material α	toner I	80	280	1.43	0.001	4.8
Example 3	photosensitive material α	toner I	80	310	1.42	0.001	3.0
Comparative Example 1	photosensitive material α	toner I	80	150	1.48	0.012	10.0
Example 4	photosensitive material α	toner II	60	250	1.45	0.001	4.0
Example 5	photosensitive material α	toner II	60	300	1.42	0.001	2.7
Example 6	photosensitive material β	toner III	60	150	1.48	0.002	4.5
Example 7	photosensitive material β	toner III	60	250	1.45	0.002	2.5
Comparative Example 2	photosensitive material β	toner III	60	120	1.46	0.010	7.0
Example 8	photosensitive material γ	toner IV	60	130	1.45	0.002	3.5
Example 9	photosensitive material γ	toner IV	60	200	1.43	0.001	2.0
Comparative Example 3	photosensitive material γ	toner IV	60	100	1.46	0.010	6.0

Claims

1. A method of setting the developing bias voltage for use in an electrophotographic method comprising:

(a) providing a photosensitive material having light attenuation characteristics represented by formula (1),

$$V = V_0 \{ A \cdot \exp(-B \cdot I) + C \cdot \exp(-D \cdot I) \} \quad (1)$$

wherein I is the amount of exposure to light (lux.sec), V is the absolute potential (volts) at the surface of the photosensitive material when the amount of exposure to light is I, V_0 is the absolute initial potential (volts) at the surface of the photosensitive material, A is from 0.7 to less than 1, and C is larger than 0 and not larger than 0.3, the total of A and C being 1, B is a coefficient from 0.1 to 1.5 lux⁻¹sec⁻¹, and D is a coefficient of from 0.01 to 0.2 lux⁻¹sec⁻¹ but less than coefficient B;

(b) electrically charging the photosensitive material;

(c) exposing the photosensitive material to image-bearing light to form an electrostatic latent image; and

(d) developing the electrostatic latent image under the application of a developing bias voltage, wherein the developing bias voltage is set to a potential which has a polarity the same as the polarity of the electric charge of the photosensitive material, wherein the setting method comprises determining the potential (E_H) corresponding to the point of intersection between light attenuation characteristic curves approximating (i) the zone of large amount of exposure to light represented by a straight line obtained by connecting a point at which the electric potential is 0.9 V_0C and a point at which the electric potential is 0.8 V_0C and (ii) the zone of small amount of exposure to light represented by a straight line obtained by connecting a point at which the electric potential is 0.9 V_0A and a point at which the electric potential is 0.7 V_0A , in a graph plotting logarithmic values of the surface potential against the amount of exposure to light and setting the absolute value of the developing voltage to be higher than E_H .

2. A method according to claim 1, wherein an organic photosensitive material is used as the photosensitive material.

3. A method according to claim 2, wherein a single-dispersion-layer photosensitive material is used as the photosensitive material.

Patentansprüche

1. Verfahren zur Einstellung der Entwicklungsvorspannung zur Verwendung in einem elektrophotografischen Verfahren, umfassend:

(a) das Bereitstellen eines lichtempfindlichen Materials mit Lichtabschwächungseigenschaften, die durch die folgende Formel (1) wiedergegeben werden

$$V = V_0 \{ A \cdot \exp(-B \cdot I) + C \cdot \exp(-D \cdot I) \} \quad \dots \quad (1)$$

wobei I der Betrag der Belichtung mit Licht (lux.sec) bedeutet, V das absolute Potential (Volt) an der Oberfläche des lichtempfindlichen Materials, wenn der Belichtungsbetrag mit Licht I ist, bedeutet, V_0 das absolute anfängliche Potential (Volt) an der Oberfläche des lichtempfindlichen Materials bedeutet, A einen Wert von 0,7 bis weniger als 1 hat und C größer als 0 und nicht größer als 0,3 ist, wobei der Gesamtwert von A und C 1 beträgt, B einen Koeffizienten von 0,1 bis 1,5 lux⁻¹sec⁻¹ bedeutet und D einen Koeffizienten von 0,01 bis 0,2 lux⁻¹sec⁻¹ bedeutet, jedoch kleiner als der Koeffizient B ist;

(b) das elektrische Aufladen des lichtempfindlichen Materials;

(c) das Belichten des lichtempfindlichen Materials mit bildtragendem Licht unter Bildung eines elektrostatischen latenten Bildes; und

(d) das Entwickeln des elektrostatischen latenten Bildes unter Anlegen einer Entwicklungsvorspannung, wobei die Entwicklungsvorspannung auf ein Potential eingestellt wird, dessen Polarität gleich mit der Polarität der elektrischen Ladung des lichtempfindlichen Materials ist,

wobei das Einstellverfahren folgendes umfasst: das Bestimmen des Potentials (E_H), das dem Schnittpunkt zwischen Kurven der Lichtabschwächungscharakteristik entspricht, die sich annähern (i) an die Zone eines hohen Belichtungsbetrags, die durch eine Gerade wiedergegeben wird, die man durch Verbinden eines Punkts, an dem das elektrische Potential 0,9 V_0C beträgt, mit einem Punkt, an dem das elektrische Potential 0,8 V_0C beträgt, erhält, und (ii) an die Zone eines geringen Belichtungsbetrags, die durch eine Gerade wiedergegeben wird, die man durch Verbinden eines Punkts, an dem das elektrische Potential 0,9 V_0A beträgt, mit einem Punkt, an dem das elektrische Potential 0,7 V_0A beträgt, erhält, und zwar in einem Diagramm, in dem die logarithmi-

schen Werte des Oberflächenpotentials gegen den Belichtungsbetrag aufgetragen sind, und das Einstellen des absoluten Werts der Entwicklungsvorspannung auf einen Wert, der größer als E_H ist.

2. Verfahren nach Anspruch 1, wobei ein organisches lichtempfindliches Material als lichtempfindliches Material verwendet wird.

3. Verfahren nach Anspruch 2, wobei ein lichtempfindliches Material in Form einer Einzeldispersionschicht als lichtempfindliches Material verwendet wird.

Revendications

1. Procédé pour régler la tension de polarisation de développement pour usage dans un procédé électrophotographique comprenant :

(a) la fourniture d'un matériau photosensible ayant des caractéristiques d'atténuation de lumière représentées par la formule (1),

$$V = V_0 \{ A \cdot \exp(- B \cdot I) + C \cdot \exp(- D \cdot I) \} \dots (1)$$

où I est la quantité d'exposition à la lumière (lux.s), V est le potentiel absolu (volts) à la surface du matériau photosensible lorsque la quantité d'exposition à la lumière est I, V_0 est le potentiel initial absolu (volts) à la surface du matériau photosensible, A est compris entre 0,7 et moins de 1, et C est plus grand que 0 et n'est pas plus grand que 0,3, le total de A et C étant 1, B est un coefficient compris entre 0,1 et $1,5 \text{ lux}^{-1} \cdot \text{s}^{-1}$, et D est un coefficient compris entre 0,01 et $0,2 \text{ lux}^{-1} \cdot \text{s}^{-1}$ mais inférieur au coefficient B ;

(b) la charge électriquement du matériau photosensible ;

(c) l'exposition du matériau photosensible à de la lumière porteuse d'image pour former une image latente électrostatique ; et

(d) le développement de l'image latente électrostatique sous application d'une tension de polarisation de développement, la tension de polarisation de développement étant réglée à un potentiel qui a la même polarité que la polarité de la charge électrique du matériau photosensible, dans lequel le procédé de réglage comporte la détermination du potentiel (E_H), correspondant au point d'intersection entre les courbes de caractéristique d'atténuation de lumière qui sont une approximation (i) de la zone de grande quantité d'exposition à la lumière représentée par une ligne droite obtenue en reliant un point en lequel le potentiel électrique est $0,9 V_0 C$ et un point en lequel le potentiel électrique est $0,8 V_0 C$ et (ii) de la zone de petite quantité d'exposition à la lumière représentée par une ligne droite obtenue en reliant un point en lequel le potentiel électrique est $0,9 V_0 A$ et un point en lequel le potentiel électrique est $0,7 V_0 A$, dans un graphique représentant des valeurs logarithmiques du potentiel de surface en fonction de la quantité d'exposition à la lumière et le réglage de la valeur absolue de la tension de polarisation de développement pour être supérieure à E_H .

2. Procédé selon la revendication 1, dans lequel un matériau photosensible organique est utilisé en tant que matériau photosensible.

3. Procédé selon la revendication 2, dans lequel un matériau photosensible à couche de dispersion unique est utilisé en tant que matériau photosensible.

FIG. 1

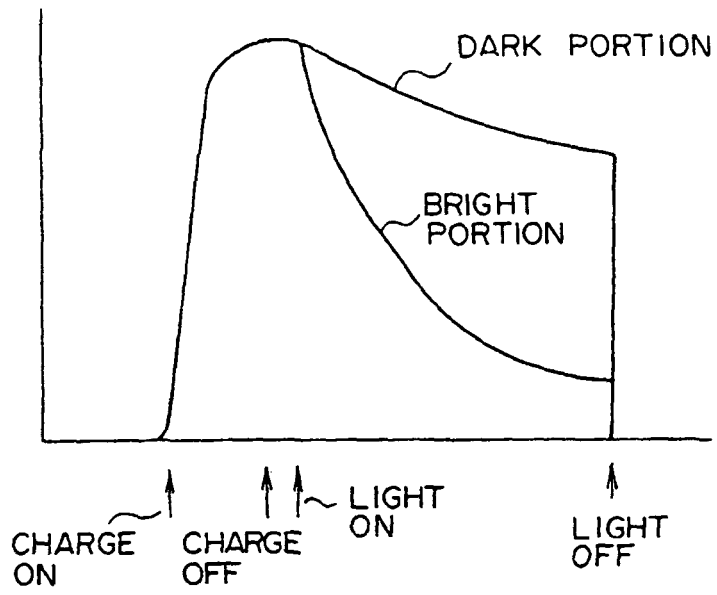

FIG. 2

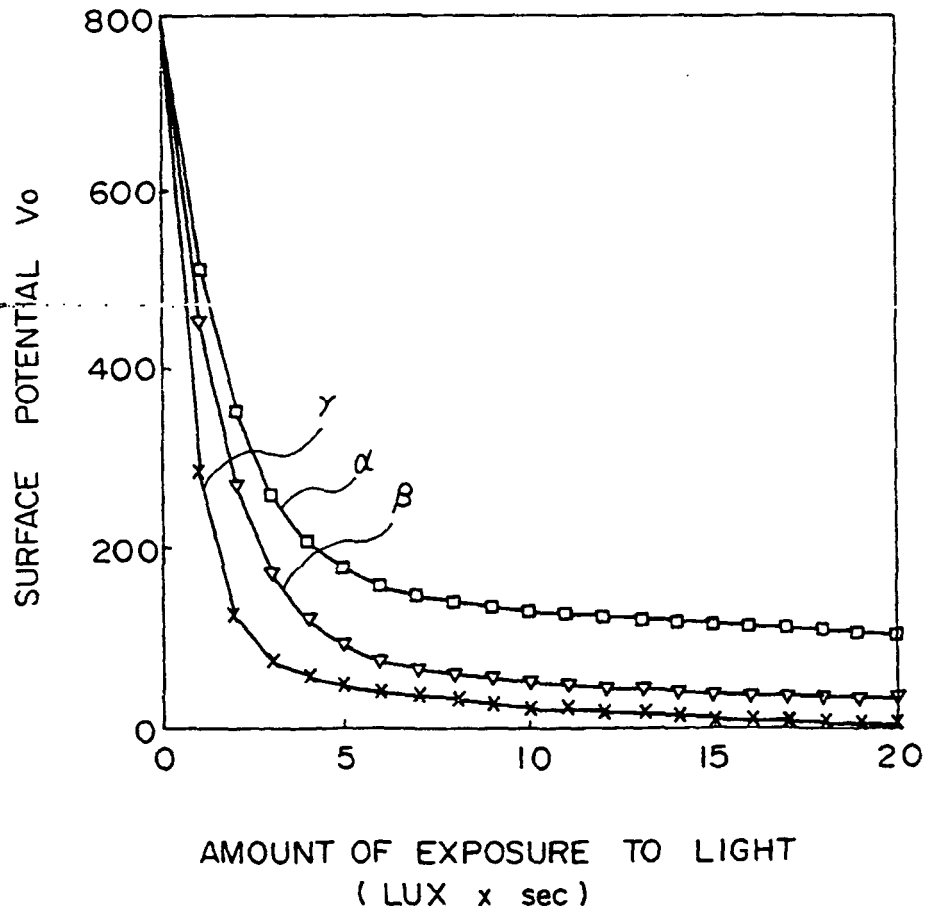

FIG. 3

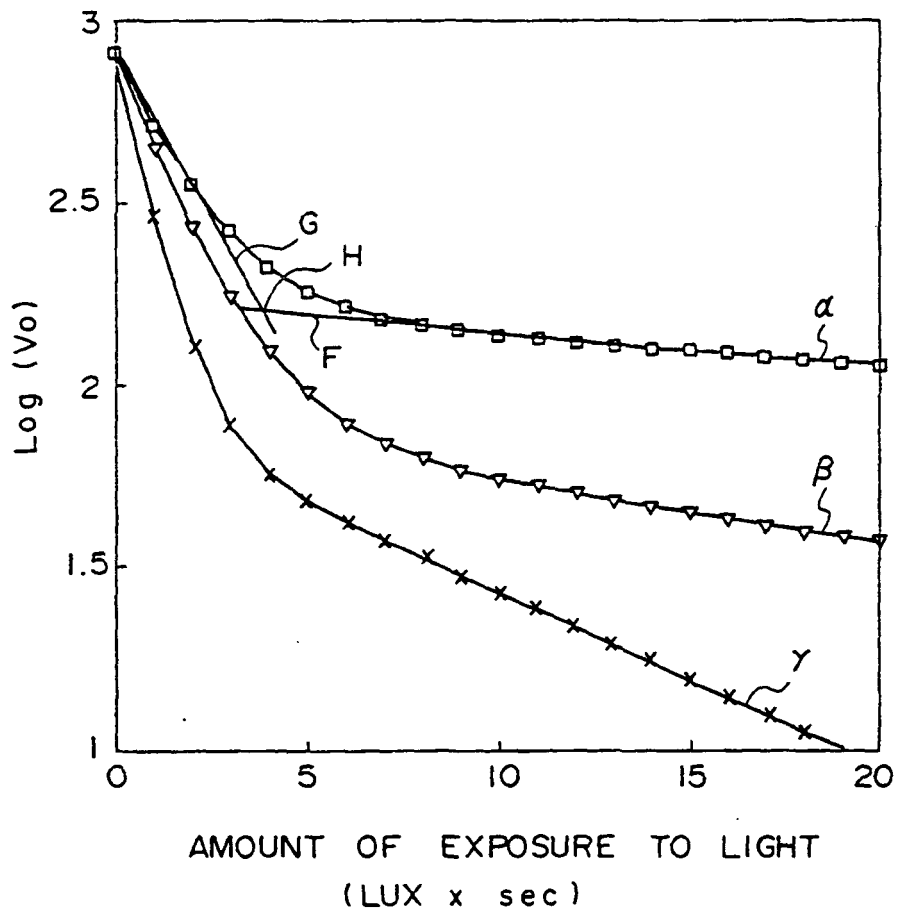

FIG. 4

CURVE REPRESENTING DEVELOPING SENSITIVITY

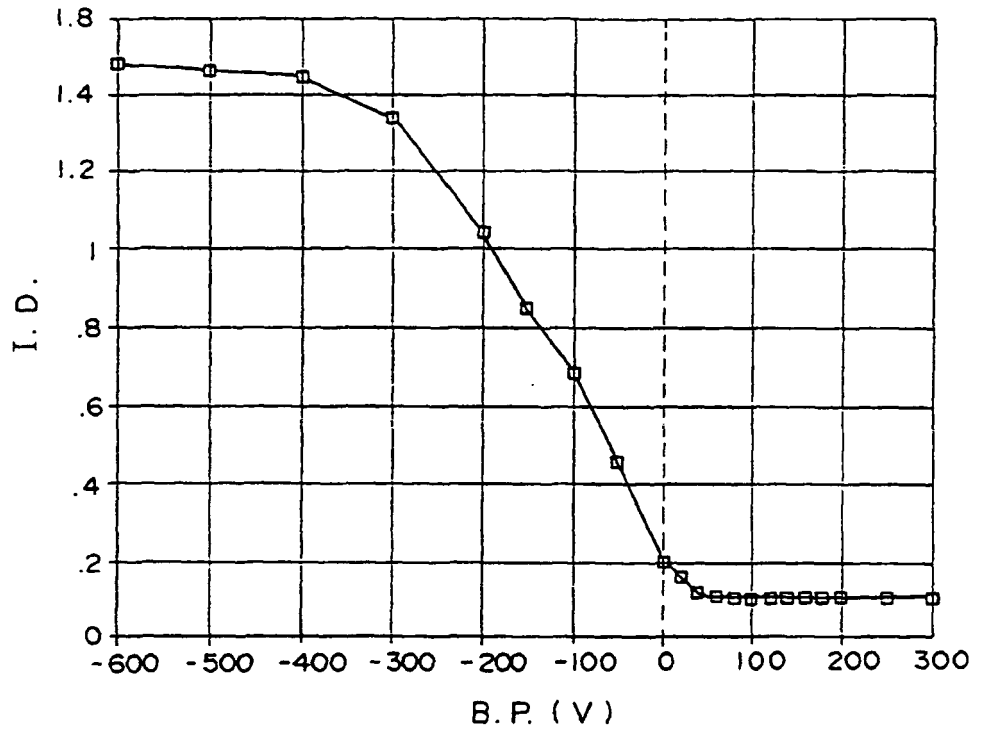

FIG. 5

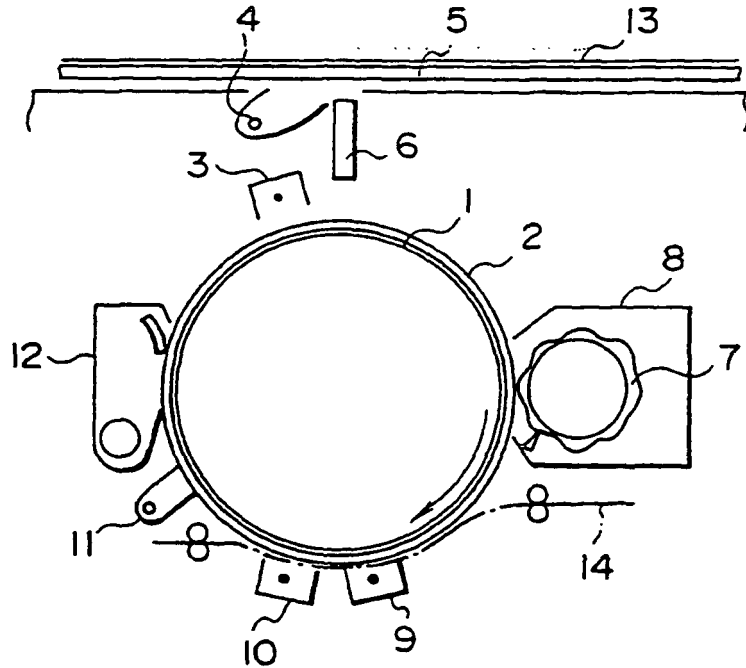

FIG. 6

