

(No Model.)

A. LEVEDAHL.

DRIVING MECHANISM FOR COTTON PICKING FINGERS.

No. 526,158.

Patented Sept. 18, 1894.

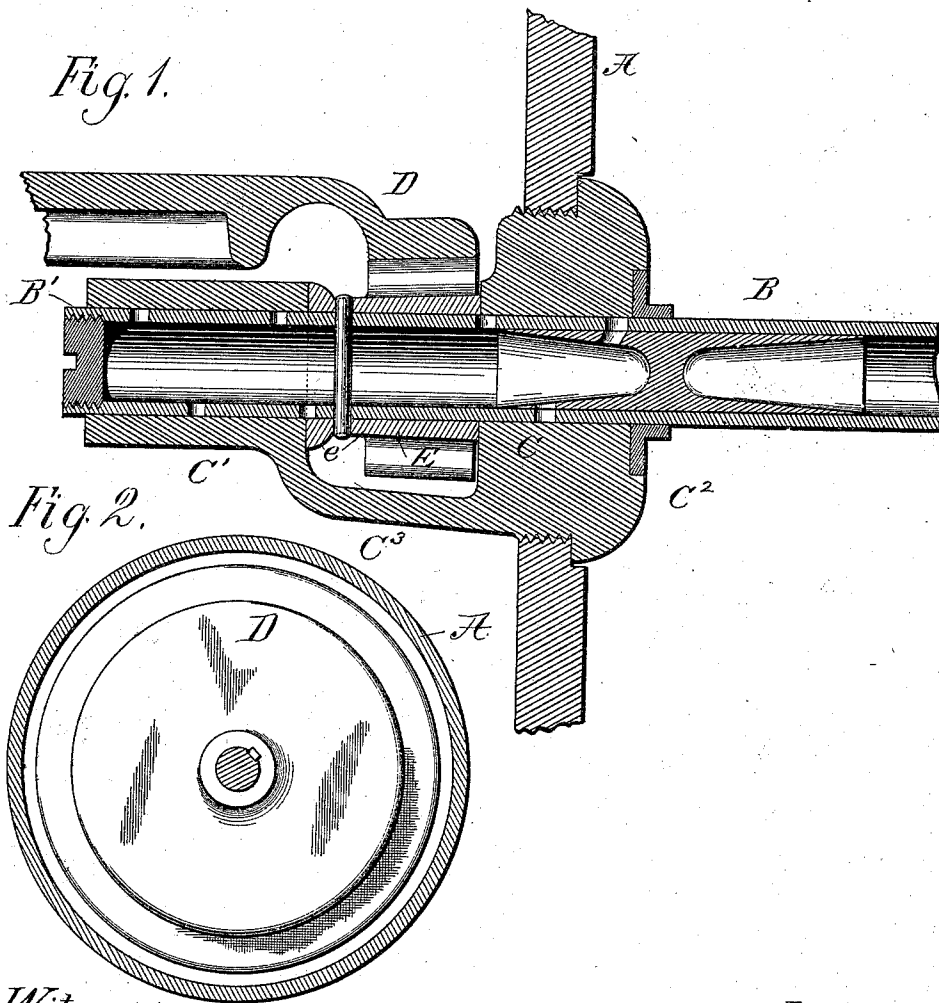

Witnesses.
C. H. Robinson
Louis H. F. Whitehead.

Inventor.
Axel Levedahl
by Dayton Pool & Brown
Attys.

UNITED STATES PATENT OFFICE.

AXEL LEVEDAHL, OF AURORA, ILLINOIS, ASSIGNOR TO THE GARDNER SEWING MACHINE COMPANY, OF SAME PLACE.

DRIVING MECHANISM FOR COTTON-PICKING FINGERS.

SPECIFICATION forming part of Letters Patent No. 526,158, dated September 18, 1894.

Application filed April 21, 1892. Serial No. 430,109. (No model.)

To all whom it may concern:

Be it known that I, AXEL LEVEDAHL, of Aurora, in the county of Kane and State of Illinois, have invented certain new and useful Improvements in Driving Mechanism for Cotton-Picker Fingers; and I do hereby declare that the following is a full, clear, and exact description thereof, reference being had to the accompanying drawings, and to the letters of reference marked thereon, which form a part of this specification.

This invention relates to the class of cotton picking machines in which a rotating hollow cylinder or drum carries a large number of radial, rotating picker fingers or stems which are rotated by gearing within the drum consisting of beveled pinions on the picker finger shafts engaged by beveled racks or beveled gear wheels mounted in the drum. In this class of machines it is necessary in order to secure the desired speed of each picker finger without giving rotation to the driving gears, that said gears should be made as large as possible, thus necessitating the placing of the pinions on the picker fingers as close as possible to the wall of the drum.

The object of this invention is to enable such relation of parts to be secured without sacrificing the necessary length and rigidity of bearing for the picker finger shaft, and to this end the invention consists in an improved construction in such bearings which will be fully understood from the following description of a construction embodying my invention.

Referring to the accompanying drawings in illustration of my invention, Figure 1 of said drawings represents a part of the drum, the picker finger shaft, the bearing of said finger shaft, the pinion of said shaft and a part of the driving wheel, all in axial section. Fig. 2 is a plan view of a drum and a driving wheel within the drum.

A is the drum.

B is a picker finger of which B' is the shaft. C is the bearing for the shaft B'.

D is a driving wheel, and E is the pinion secured upon the finger shaft B'.

It will be observed that the bearing C is shown as an integral casting composed of the

two parts C' C² connected by the arm C³. The parts C' C² are both apertured to receive the shaft B' of the picker finger and are separated from each other by a space occupied by the hub e of the pinion E, which space is adjacent to the inner surface of the drum A. By the division of the bearing and the transposition of the pinion E from the inner extremity of the finger shaft to the position here indicated, the driving wheel or rack D is made much larger in diameter and enough larger to enable it to be made non-rotative or stationary and yet to produce the desired high speed of the picker fingers which are rotated thereby.

It is obvious that the driving wheels D may be held from rotation by any one of various suitable devices, as for example, by a squared or splined, non-rotative shaft passing through the wheels in the axis of the drum, as indicated in Fig. 2.

The improved bearing, as described, is simple and inexpensive to manufacture and, while securing a firm support for the picker finger, enables the parts to be so arranged that the driving gears may be of the largest practical diameter.

I claim as my invention—

In a cotton picker, the combination with a finger carrying drum, and a radial rotative picker finger projecting through an aperture in said drum, of an integral two-part bearing for the picker finger shaft adapted to be inserted through said aperture and the separated parts of which are connected at one side by an arm integral with said parts, the outer part of the bearing being secured within and closing the aperture, a pinion fixed to the picker finger shaft between the parts of the bearing, and a driving gear mounted within the drum and engaging said pinion, substantially as described.

In testimony that I claim the foregoing as my invention I affix my signature in presence of two witnesses.

AXEL LEVEDAHL.

Witnesses:

M. E. DAYTON,
TAYLOR E. BROWN.