

(No Model.)

4 Sheets—Sheet 1.

G. F. BROTT.  
Steam Boiler.

No. 235,124.

Patented Dec. 7, 1880.

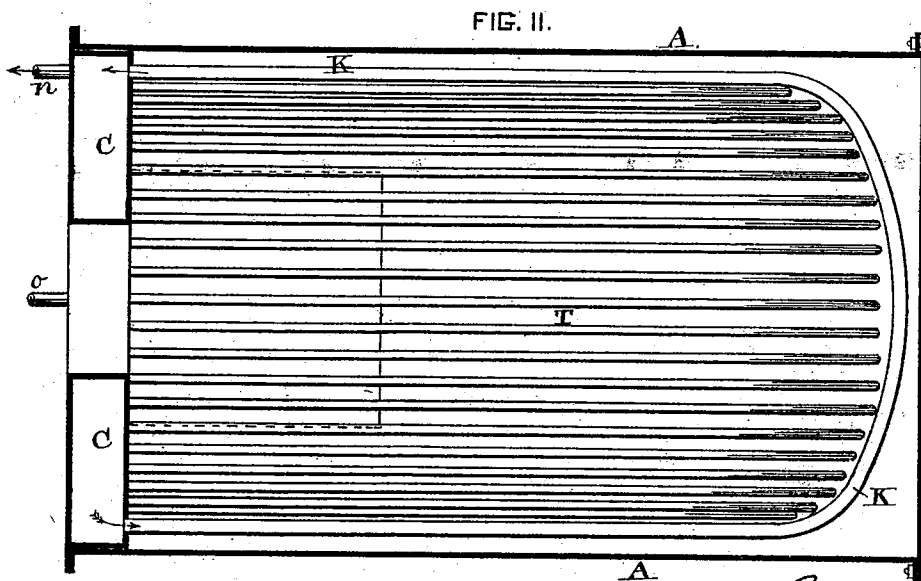
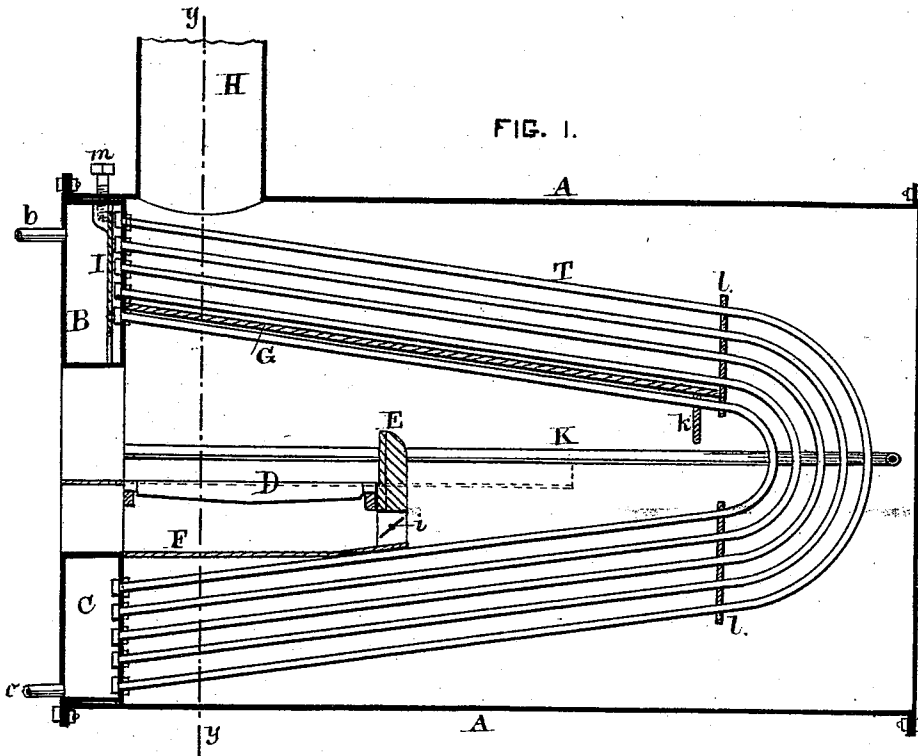

*George F. Brott.*  
INVENTOR:

WITNESSES:  
*James Nich & Coles*  
*M. S. Callan*

(No Model.)

4 Sheets—Sheet 2.

G. F. BROTT.  
Steam Boiler.

No. 235,124.

Patented Dec. 7, 1880.

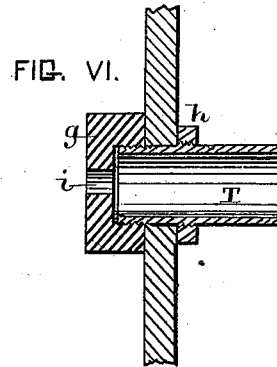
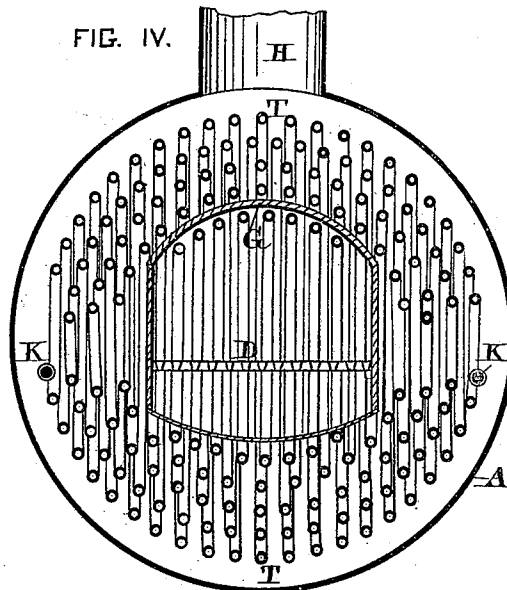
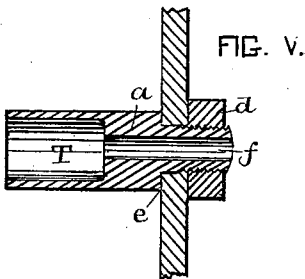
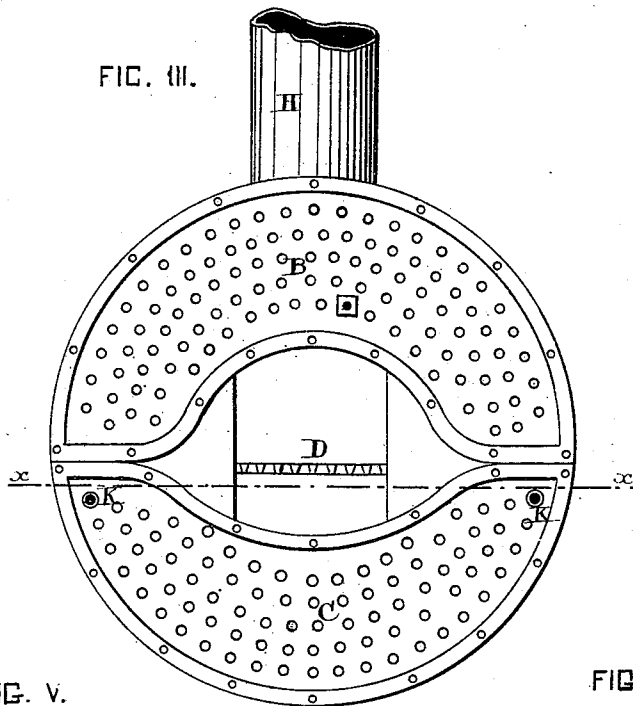

*George F. Brott*

INVENTOR:

WITNESSES:

*James Nich. Ballan*

*M. S. Ballan*

(No Model.)

4 Sheets—Sheet 3.

G. F. BROTT.  
Steam Boiler.

No. 235,124.

Patented Dec. 7, 1880.

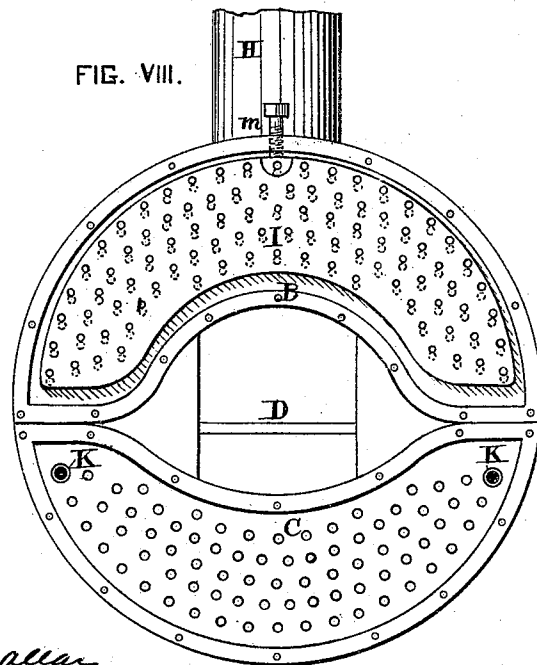
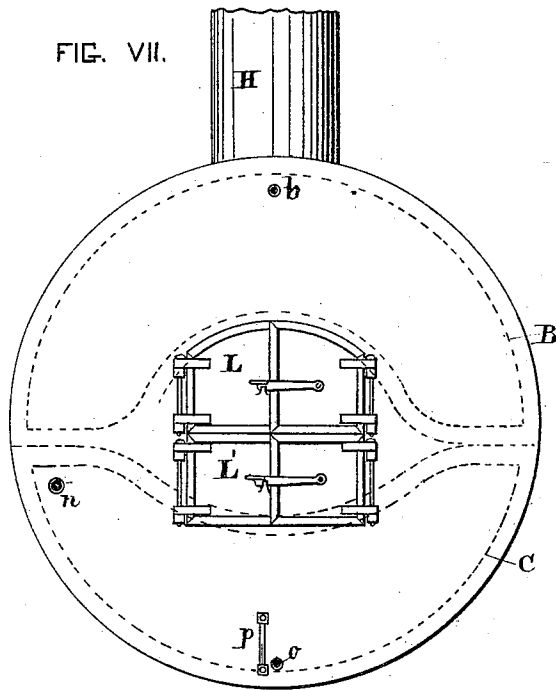

WITNESSES:

*James Mich-Sullivan*  
*M. S. Callan*

*George F. Brot*  
INVENTOR:

(No Model.)

4 Sheets—Sheet 4.

G. F. BROTT.  
Steam Boiler.

No. 235,124.

Patented Dec. 7, 1880.

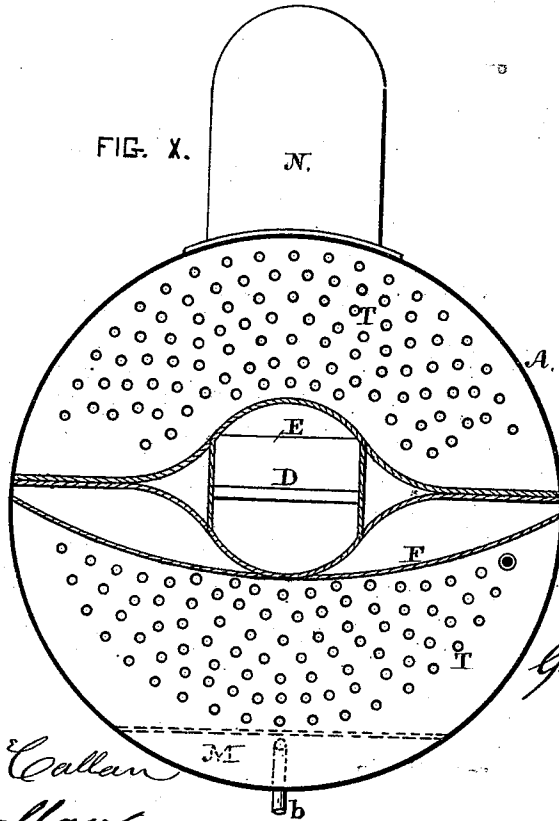
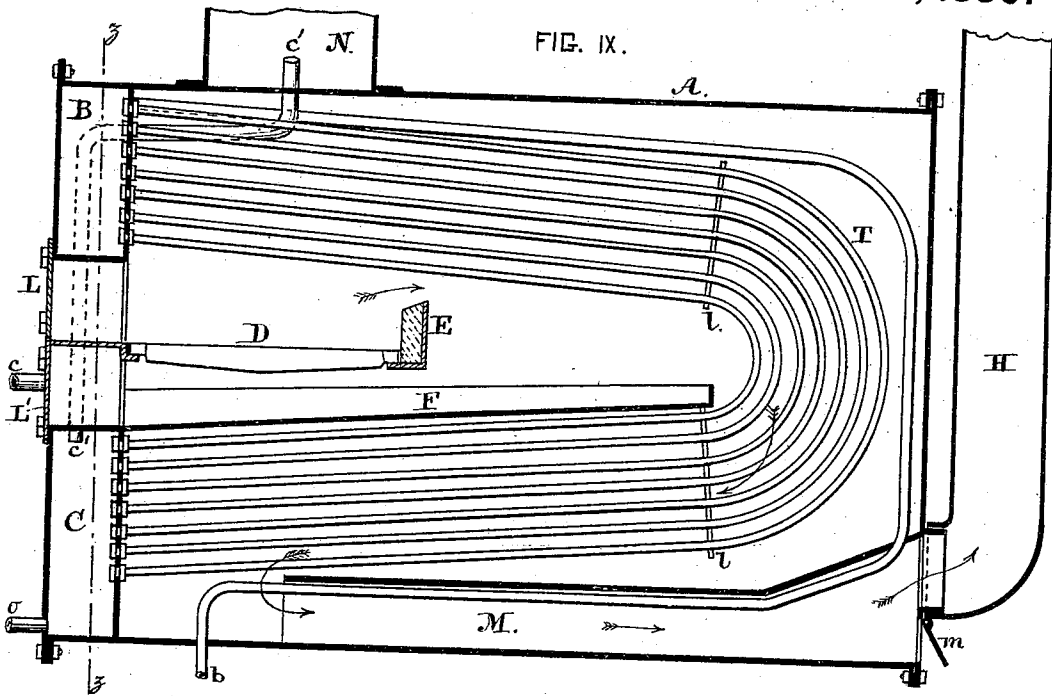

WITNESSES,

*James Mich Callan*  
*M. S. Callan*

*George F. Brott,*  
INVENTOR.

# UNITED STATES PATENT OFFICE.

GEORGE F. BROTT, OF WASHINGTON, DISTRICT OF COLUMBIA.

## STEAM-BOILER.

SPECIFICATION forming part of Letters Patent No. 235,124, dated December 7, 1880.

Application filed May 8, 1880. (No model.)

To all whom it may concern:

Be it known that I, GEORGE F. BROTT, a citizen of Washington city, residing at Washington city, in the county of Washington, District of Columbia, have invented certain new and useful Improvements in Steam Boilers or Generators; and I do hereby declare the following to be a full, clear, and exact description of the invention, such as will enable others skilled in the art to which it appertains to make and use the same, reference being had to the accompanying drawings, and to letters or figures of reference marked thereon, which form a part of this specification.

My invention relates to steam boilers or generators of the class called "sectional;" and the object is to produce a boiler or generator that will generate steam very rapidly, is entirely free from danger by explosion, can be constructed at very small cost, and its parts can expand and contract freely.

The invention consists in the construction and arrangement of the parts of the boiler, as will be hereinafter described, reference being had to the accompanying drawings, in which—

Figure I represents a vertical longitudinal section. Fig. II is a horizontal section on line *x x*, Fig. III. Fig. III is an end view with the head removed. Fig. IV is a cross-section on line *y y*, Fig. I. Figs. V and VI show tube-fastenings on an enlarged scale. Fig. VII is a front view of the boiler. Fig. VIII is a front view with the head removed, showing a valve or plate for governing the size of tube-inlet. Fig. IX is a longitudinal section of a modification. Fig. X is a cross-section on line *z z*, Fig. IX.

In the drawings, A is an outer shell, to which, at its front end, is secured, in any suitable manner—preferably by bolts, so as to be removable—two chambers or hollow heads, B C. The chamber B at the upper side of the boiler forms the water-chamber, into which the feed-water is introduced by a pipe, *b*, while the lower chamber forms the steam-chamber, from which the steam generated is withdrawn through pipe *c*.

To the inner side of the chambers B C are attached a number of U-shaped tubes, T, which are preferably held in place as shown in Figs.

V and VI. In Fig. V the tubes are provided with a solid part, *a*, which is provided at its outer end with a screw-thread for the nut *d*, while the inner end forms a shoulder, *e*, which bears against the tube-sheet. A hole, *f*, of smaller diameter than the diameter of the tube, is bored through the nut, so as to limit and regulate the supply of water to a minimum. As a modification of this tube-fastening, the one shown in Fig. VI may be employed, which consists of a recessed nut, *g*, in which the tube end is held, while a collar, *h*, may be welded to the tube, or in its place a nut may be employed. The hole *i* through the nut *g* is also of reduced diameter in this instance.

Between the tubes is arranged a suitable grate, D, or a proper pan or receptacle for oil when it is desired to burn hydrocarbons. At the rear end of the grate is a bridge-wall, E, and this is provided with a damper, *i*, below it, for the admission of air. Below the grate is arranged a plate or receptacle, F, into which the ashes fall and can be withdrawn.

Between any of the rows of tubes is arranged, preferably, a cast-iron plate, G, extending to near the back of the tube. This plate may be of any other material and may be covered with any refractory material. This plate serves to guide the products of combustion toward the rear end of the boiler before passing into the chimney H. Said plate may be provided with a pendent deflector, *k*.

The tubes are held in proper position at the rear end by any suitable bars or braces *l*. In the upper chamber, B, and as close as possible to the mouth of the tubes, is arranged a sliding plate, I, (best seen in Fig. VIII,) provided with the same number of holes corresponding to the number of tubes, and it is raised and lowered by a screw, *m*, and by this plate the exact quantity of water that is to be admitted into the tubes is regulated.

A horizontal tube, K, extending from one side of the chamber C to the other side around the U-shaped tubes and passing through the heating-space, serves to superheat the steam. The steam is withdrawn from the chamber C by a pipe, *n*, (seen in Fig. VII,) and a suitable pipe, *o*, serves as the blow-off pipe.

A water-gage, *p*, is attached to the front of

the boiler, by which the amount of water accumulating in the chamber C is indicated, which can thus be regulated by the plate I.

Suitable furnace and ash-pit doors L L' are attached to the front of the boiler.

I prefer to construct the chambers B C of cast or malleable iron, although other material, such as sheet or wrought iron, may be used.

In the modification shown in Figs. IX and X is represented a double return-tube boiler, in which the plate F forms the ash-pit bottom, and is extended to the rear of the tubes, and around the end of this plate the products of combustion pass, as shown by the arrows, and thence through the lower space, M, into the chimney. A door, *m*, is arranged in the rear end for cleaning out this space.

The feed-pipe *b* may be passed into the space M and thence upward through the fire-space, in which the feed-water is heated.

A steam-dome, N, can be arranged on top of the boiler, into which dome the steam can be led by a pipe, *c'*, extending into the steam-chamber.

The advantages of my invention are, that a large amount of heating-surface is obtained in a very small space. There being no large steam-space explosions cannot occur, as the proper amount of water only is admitted to the tubes and generated into steam. Any of the parts can be easily repaired or replaced when out of order, and when a tube becomes injured in any manner the nuts are simply taken off and the tube can be withdrawn by removing the heads. There is no liability of leakage, as the parts are free to expand and contract. The tubes can be readily cleaned out by a scraper or in any other suitable manner. It has all the advantages of the coil-boiler in the rapid circulation of water being converted into steam in its passage from the upper to the lower chamber without the disadvantage of clogging up. Sufficient water can be admitted into the tubes to thoroughly clean them out and wash out all sediment in a semi-fluid state. It can be made of any length desired. It is in its action the same as a return-flue boiler. It can be adapted for locomotives,

stationary, or marine engines. The downward incline of the tubes will cause the water to pass through them by its own gravity, and is vaporized in its passage through the hot surface. The ends of the tubes being in the water and steam chambers are thereby protected from the heat of the flame, having no joints exposed to the fire.

The operation is as follows: Water is admitted through the feed-pipe *b* into chamber B, and the amount desired regulated by plate I, and passes backward and downward to the front chamber, C, in the form of steam, from where it is withdrawn by the steam-pipe U. The steam in passing from one side of the chamber C to the other through the pipe K becomes highly superheated.

Having thus described my invention, what I claim, and desire to secure by Letters Patent, is—

1. A steam-boiler having the separate water-chamber B arranged above the steam-chamber C and united by U-shaped tubes T, substantially as and for the purpose described.

2. The combination of the water-chamber B, steam-chamber C, and U-shaped tubes T with a plate, G, and furnace-grate, arranged substantially as specified.

3. The combination of a water-chamber, B, steam-chamber C, and tubes T with a plate, I, for regulating the amount of water desired, substantially as shown and set forth.

4. The combination of a water-chamber, B, steam-chamber C, and U-shaped tubes T with a shell, A, and furnace D, provided with bridge-wall E, having damper *i*, as and for the purpose specified.

5. The combination, in a boiler, of the water-chamber B, steam-chamber C, and tubes T with a curved steam-pipe, K, arranged substantially as specified.

In testimony whereof I affix my signature in presence of two witnesses.

GEORGE F. BROTT. [L. S.]

Witnesses:

JAMES NICHOLS. CALLAN,  
M. S. CALLAN.