



(12) **DEMANDE DE BREVET CANADIEN
CANADIAN PATENT APPLICATION**

(13) **A1**

(86) **Date de dépôt PCT/PCT Filing Date:** 2017/12/15
 (87) **Date publication PCT/PCT Publication Date:** 2018/06/28
 (85) **Entrée phase nationale/National Entry:** 2019/06/04
 (86) **N° demande PCT/PCT Application No.:** EP 2017/083004
 (87) **N° publication PCT/PCT Publication No.:** 2018/114659
 (30) **Priorité/Priority:** 2016/12/22 (DE10 2016 125 452.5)

(51) **Cl.Int./Int.Cl. F01D 5/28** (2006.01),
B29C 53/62 (2006.01), **B29C 70/32** (2006.01),
B29D 99/00 (2010.01), **F03D 1/06** (2006.01),
B29C 53/58 (2006.01), **B64C 27/473** (2006.01)
 (71) **Demandeur/Applicant:**
 WOBVEN PROPERTIES GMBH, DE
 (72) **Inventeur/Inventor:**
 BURKNER, FALKO, DE
 (74) **Agent:** OYEN WIGGS GREEN & MUTALA LLP

(54) **Titre : PROCÉDE DE FABRICATION D'UNE PALE DE ROTOR D'EOLIENNE ET PALE DE ROTOR D'EOLIENNE**
 (54) **Title: METHOD FOR PRODUCING A WIND TURBINE ROTOR BLADE AND WIND TURBINE ROTOR BLADE**

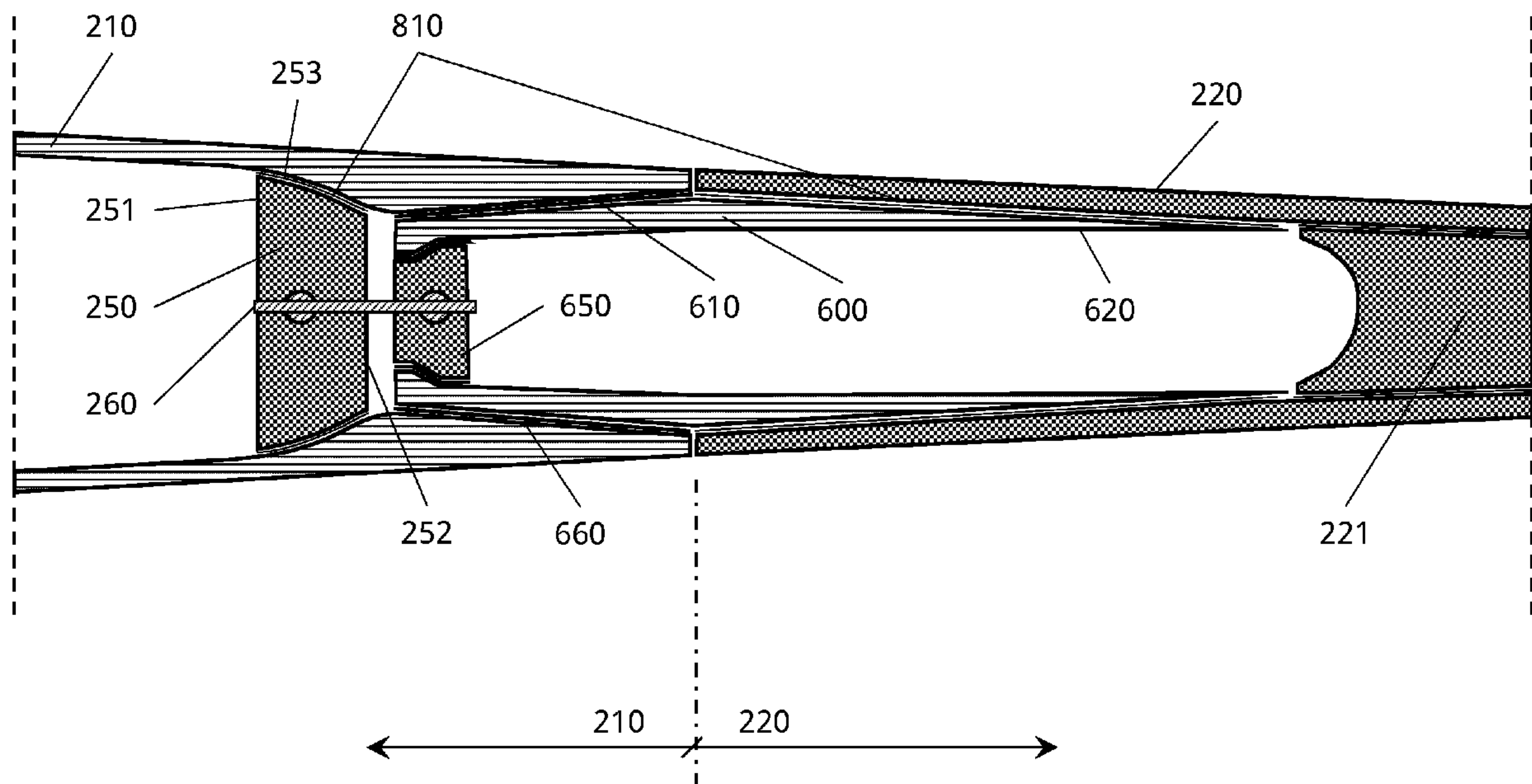

Fig. 5

(57) **Abrégé/Abstract:**

A method for producing a wind turbine rotor blade (200) is disclosed. The wind turbine rotor blade (200) has at least one inner blade section (210) and an outer blade section (220) as well as a connection element (600). The inner blade section (210) is wound on a winding form which has a first and a second winding section. The first and second winding sections are secured to one another in a releasable manner by means of a screw connection. The second winding section has a conical design so that, after the winding of the inner blade section (210), a sleeve is produced at one end of the inner blade section (210).

Abstract

A method of producing a wind turbine rotor blade (200). The wind turbine rotor blade (200) has at least an inner blade portion (210) and an outer blade portion (220), as well as a connecting element (600). The inner blade portion (210) is wound on a winding form having a first and a second winding portion. The first and second winding portions are releasably fixed to each other by way of a screw connection. The second winding portion is of a conical configuration so that after winding of the inner blade portion (210) a sleeve is produced at an end of the inner blade portion (210).

(Figure 2)

Method for producing a wind turbine rotor blade
and wind turbine rotor blade

5

The present invention concerns a method of producing a wind turbine rotor blade and a wind turbine rotor blade.

10

US 2007/0253824 A1 discloses a modular rotor blade of a wind turbine. The rotor blade is of a two-part configuration and has an inner blade portion and an outer blade portion. The inner blade portion and the outer blade portion can be fixed to each other or fixed together by means of a connecting element. Transport of the rotor blade can be considerably simplified by virtue of the multi-part structure of the rotor blade. The connection between the inner blade portion and the outer blade portion is effected by vacuum infusion. Vacuum infusion at that location however is difficult and time-consuming.

15

On the German patent application from which priority is claimed the German Patent and Trade Mark Office searched the following documents: US 2007/0253825 A1, DE 32 39 804 A1, DE 10 2008 055 513 B4 and US 2014/0169978 A1.

20

Therefore an object of the present invention is to provide a wind turbine rotor blade which is of a multi-part configuration and at least partially overcomes the above-indicated disadvantages. In particular an object of the present invention is to provide a wind turbine rotor blade which is of a multi-part configuration and which has an improved connection between the respective parts.

25

That object is attained by a method of producing a wind turbine rotor blade according to claim 1 and by a wind turbine rotor blade according to claim 5.

30

Thus there is provided a method of producing a wind turbine rotor blade. The wind turbine rotor blade has at least an inner blade portion and an outer blade portion, as well as a connecting element. The inner blade

portion is wound on a winding form having a first and a second winding portion. The first and second winding portions are releasably fixed to each other by way of a screw connection. The second winding portion is of a conical configuration so that after winding of the inner blade portion a sleeve is produced at an end of the inner blade portion.

According to an aspect of the present invention the connecting element is wound on a winding form. The connecting element has a first and a second portion.

According to a further aspect of the present invention a form having a conical internal shape is pushed on to the first portion of the connecting element before the winding laminate is hardened in order to provide a first portion of a conical configuration and having a smooth surface.

According to a further aspect of the present invention the at least one inner blade portion and the at least one outer blade portion are releasably connected together or adhesively bonded together by way of the connecting element.

The invention also concerns a wind turbine rotor blade comprising an inner blade portion, an outer blade portion, and a connecting element for connecting the inner blade portion and the outer blade portion. The inner blade portion has a sleeve at a first end, which is achieved by winding of the inner blade portion. The at least one inner blade portion and at least one outer blade portion can be fixed together by way of a screw connection so that the inner blade portion is fixed to the outer blade portion by way of the connecting element.

In a further aspect of the present invention the inner blade portion can have at least one first web which is glued thereto. The connecting element is introduced into the sleeves of the inner blade portion with its first end which has a second web glued therein. The second end of the connecting element can be glued in an end of the outer blade portion.

The wind turbine rotor blade is at least of a two-part configuration and has an inner blade portion and an outer blade portion. The inner blade portion has for example the rotor blade root and is secured to a hub of the wind turbine. At an opposite end the inner blade portion has a receiving

unit or sleeve into which a connecting element can be partially introduced. The rotor blade further has an outer blade portion which can be fixed to the inner blade portion by means of the connecting element.

5 With the wind turbine rotor blade according to the invention it is possible to avoid complicated and laborious milling operations at both sides of the blade separation junction. In addition complicated and expensive flange laminates can be avoided in the region of the outer blade.

10 According to an aspect of the present invention the blade separation junction can also be displaced outwardly. That makes it possible to better divide up the units for transport. Furthermore inexpensive inner blade production can be expanded by virtue of the winding laminate. In addition quicker assembly can be made possible on the building site. Finally, it is also possible to avoid a thickening of the profile configuration, as in the case of a classic transverse bolt connection.

15 According to an aspect of the present invention a contact plane between the sleeve of the inner blade portion and the push-in member (connecting element) is of a conical configuration involving a given angle in order to permit clean assembly and separation of the connection. A gap can be defined by virtue thereof between the inner blade and the outer
20 blade. That concerns the position of the blade parts in the longitudinal direction after being fitted together and braced in position. Furthermore the cross-section of the contact plane can be not round but for example elliptical in order also to be able to better transmit torsional loads without having to rely only on frictional forces. Furthermore the contact plane can
25 be of such a configuration that only two regions are in contact at the beginning and at the end in the longitudinal direction. That can provide for load transfer in a more defined and more predictable fashion. The regions of high accuracy are reduced and the clamping action by virtue of the biasing effect is enhanced. By virtue of the precise shaping of the sleeve
30 by virtue of a precisely manufactured winding form it is possible to provide that the surfaces are of the desired shape without having to be subsequently milled.

The precise shaping of the push-in member (connecting element) can be achieved by a precisely produced negative form which is pushed on to the winding laminate which has been freshly wound and has not yet hardened without having to mill the surface after hardening to impart the
5 desired shape.

Further configurations of the invention are subject-matter of the appendant claims.

Advantages and embodiments by way of example of the invention are described in greater detail hereinafter with reference to the drawing.

10 Figure 1 shows a diagrammatic view of a wind turbine according to the invention,

Figure 2 shows a diagrammatic view of an inner blade portion during manufacture thereof,

15 Figure 3 shows a diagrammatic sectional view of a connecting element upon manufacture thereof,

Figure 4 shows a diagrammatic side view of a connecting element during manufacture thereof,

Figure 5 shows a diagrammatic sectional view of a part of a wind turbine rotor blade,

20 Figure 6 shows a diagrammatic sectional view of an inner blade portion during manufacture thereof,

Figure 7 shows a diagrammatic sectional view of an inner blade portion during manufacture thereof,

25 Figure 8 shows a diagrammatic sectional view of an inner blade portion during manufacture thereof,

Figure 9 shows a diagrammatic sectional view of an inner blade portion during manufacture thereof,

Figure 10 shows a diagrammatic sectional view of the connecting element during manufacture thereof,

30 Figure 11 shows a further diagrammatic sectional view of a connecting element during manufacture thereof, and

Figure 12 shows a further diagrammatic sectional view of a connecting element during manufacture thereof.

Figure 1 shows a diagrammatic view of a wind turbine. The wind turbine 100 has a tower 102 and a pod 104. A rotor 106 having three rotor blades 200 and a spinner 110 is provided on the pod 104. The rotor 106 is driven in rotation in operation by the wind and drives a generator in the pod 104 to generate electric energy.

The rotor blade 200 has at least two parts, namely an inner blade portion 210 and an outer blade portion 220. The outer blade portion 220 is fixed to the inner blade portion 210.

Figure 2 shows a diagrammatic sectional view of an inner blade portion during manufacture thereof. The inner blade portion 210 is wound according to the invention. For that purpose there is provided a winding core 300 with a first winding form 310 and a second winding form 320 which are fixed to each other or connected together by way of an interface 330. The first winding form portion 310 is supported by way of a bearing 340a and the second winding form portion 320 is supported by way of a further bearing 340b so that the winding form 300 can rotate.

The first winding portion 320 has a first end 311 and a second end 312. The first end 311 is coupled to the bearing 340a. The second end 312 is coupled by way of the connecting interface 3w30 to a first end 321 of the second winding portion 320. By way of example the first and second winding portions 310, 320 can be releasably fixed to each other by way of a screw connection. Optionally the diameter of the first winding portion 310 can decrease from the first end 311 to the second end 312. The diameter of the second winding portion 320 can increase from the first end 321 to the second end 322. Thus the winding form 300 can be of the smallest diameter in the region of the interface 330. That configuration of the winding unit 300 can provide that an inner blade portion with an undercut configuration 213 can be produced.

Fibre composite fabrics are wound on to the winding form 310, 320. After the inner blade portion 210 has been produced the screw connection in the region of the interface 330 can be released and the first and second winding portions 310, 320 can be separated out so that only the inner blade portion 210 in particular with the undercut configuration 213

remains. The inner blade portion 210 has a first end 211 and a second end 212. A thickening of the winding material or a flange thickening for a transverse bolt connection (for example in relation to the rotor hub) can be provided in the region of the first end 211.

5 The second winding portion 320 can be provided in the form of a sleeve shape in order to provide a sleeve in the region of the second end 212 of the inner blade portion. That sleeve serves in particular to receive an end of the connecting element.

10 According to an aspect of the present invention the first and second winding portions 310, 320 can be made from a metal like for example steel. That is particularly advantageous because it is possible in that way to provide a smooth surface on the first and second winding portions 310, 320. In particular the smooth surface of the first and/or second winding portion 320 can provide a smooth inside surface 215, 216 and in particular
15 a sleeve portion in the region of the second end 212 of the inner blade portion which is also smooth.

Figure 3 shows a diagrammatic sectional view of a connecting element upon manufacture thereof. A winding form 700 is provided for producing a connecting element 600 which for example can be in the form
20 of a connecting beam. The winding form 700 has a first and a second end 701, 702 as well as a transitional portion 703. The outside diameter of the winding form 700 is increased in the region between the transition of the first end 701 and the transitional region 703. Fibre-darkening material can be wound on to the winding form 700 which is supported for example by
25 means of bearing 710 on a foundation 400 by rotation of the winding form 700 in the material.

The connecting element 600 has a first end 611 and a second end 621. In addition the connecting element 600 has a first portion 610 in the region of the first end 611 and a second portion 620 in the region of the
30 second portion 610, 620. A central portion 630 is provided between those two portions 610, 620.

In order to achieve a smooth surface for the first portion 610 a steel form 500 can be provided for example on wheels 520. The steel form 500

is of an inside diameter 510 which narrows to a closed end 530. After the winding element 600 has been wound and before the material has hardened the steel form 500 is pushed on to the first end 610 so that the insides of the steel form bear against the first portion 610. In that way the
5 outer region of the first portion 610 can be produced as being very smooth.

Figure 4 shows a diagrammatic sectional view of a connecting element during manufacture thereof. Figure 4 shows how the steel form 500 has been pushed on to the first portion 610 of the connecting element 600 while the winding material of the connecting element 600 is still on the
10 winding form 700.

Figure 5 shows a diagrammatic sectional view of a part of a wind turbine rotor blade. Figure 5 shows in particular a blade separation junction between the inner blade portion 210 and the outer blade portion 220. The connection between the inner blade portion 210 and the outer
15 blade portion 220 is made by way of the connecting unit 600. The connecting unit 600 has a first portion 610 which has been produced as described with reference to Figures 3 and 4 and preferably has a smooth surface. The first portion 610 is introduced into the sleeve 212 of the inner blade portion 210.

20 The connecting element 600 can have a web 650 which is glued therein. A further web 250 can be glued in place in the region of the thickening portion or the undercut configuration 213. The two webs 650, 250 can be screwed together or fixed to each other by means of a transverse bolt 260. The second portion 620 of the connecting unit is
25 pushed into an open end of the outer blade 220 and preferably glued by means of an adhesive 810.

In optimum fashion an anti-friction coating 660 can be provided in the region of the sleeve. The first end of the connecting element can thus be pushed into the sleeve portion 212 and fixed by means of the webs 250,
30 650 and the transverse bolt 260.

That makes it possible to achieve a reversible fixing option between the inner blade portion and the outer blade portion.

Figure 6 shows a diagrammatic sectional view of an inner blade portion during manufacture thereof. Figure 6 shows an alternative winding form 340 in relation to the winding form shown in Figure 2. While the winding form in Figure 2 comprises steel the winding form 340 in Figure 6
5 comprises for example a fibre composite material. The winding form 340 does not have to be removed from the inner blade portion but can remain therein. Accordingly the winding form 340 represents a lost winding form because it remains in the inner blade portion.

The winding form 340 has a first end 341 and a second end 342 as
10 well as a steel connection 344, by way of which the winding form is connected to a bearing 340a. The bearing 340a can be provided on a foundation 400. The winding form 340 can for example have a plurality of transverse stiffening members 343. By virtue of the fact that the winding form 340 does not have to be removed from the blade portion the first end
15 211 of the inner blade portion 210 can be wider so that a flange thickening configuration for example for making transverse bolt connections can be provided. The material of the inner blade portion 210 can be wound on to the winding form 340. The winding form 340 can be coupled to a second winding form 320 for example by way of a screw connection. In that case
20 that second winding form 320 corresponds to the winding form 320 shown in Figure 2. That winding form is intended in particular to produce a sleeve shape for the inner blade. After the inner blade portion 210 has been produced the second sleeve form 320 can be removed by releasing the screw connections. Optionally the steel connection 344 can remain in the
25 winding form 340 or removed.

Figure 7 shows a diagrammatic sectional view of an inner blade portion during manufacture thereof. Figure 7 shows in particular how the material is wound on to the winding form 310, 320. Optionally the winding form 310 can have studs 310a and the second winding form 320 can have
30 studs 310b. According to the invention therefore a winding laminate can be applied to the winding form.

After a first layer of winding laminate has been applied to the winding form at least one layer of unidirectional UD rovings can be applied. In that case the rovings can be applied around the studs 310a, 310b.

Optionally the outside of the first winding laminate layer can be of a substantially straight configuration so that the unidirectional UD rovings can be simply placed thereon.

Figure 9 shows a diagrammatic sectional view of an inner blade portion during manufacture thereof.

Figure 10 shows a diagrammatic sectional view of the connecting element during manufacture thereof.

Figures 10 to 12 show in particular the production of the connecting element 600. A first layer of winding laminate FKV1 is applied to the winding form 700 so that a straight line is provided at the outside. Unidirectional UD rovings can be provided thereon by means of the rovings. In particular the rovings can be wound around the studs 700a, 700b. A second layer of winding laminate FKV can then be applied.

CLAIMS

1. A method of producing a wind turbine rotor blade which has at
5 least one inner blade portion (210) and at least one outer blade portion
(220) and a connecting element (600) for connecting the at least one inner
blade portion (210) and the at least one outer blade portion (220),
comprising the steps:

winding the inner blade portion (210) on a winding form (310)
10 having a first and a second winding portion (310, 320), wherein the first
and second winding portions (310, 320) are fixed to each other,

wherein the second winding portion (220) is of a conical
configuration so that after winding of the inner blade portion (210) a sleeve
is produced at an end of the inner blade portion (210).

15

2. A method according to claim 1 comprising the step:

winding the connecting element (600) for connecting the inner blade
portion (210) and the outer blade portion (220) on a winding form (700),

wherein the connecting element (600) has a first and a second
20 portion (610, 620).

3. A method according to claim 2 wherein

a form (500) having a conical shape is pushed on to the first portion
of the connecting element (600) before the winding laminate is hardened in
25 order to provide a first portion (610) of a conical configuration and having a
smooth surface.

4. A method according to one of claims 1 to 3 wherein

the at least one inner blade portion (210) and the at least one outer
30 blade portion (220) are releasably connected together or adhesively
bonded together by way of the connecting element (600).

5. A wind turbine rotor blade (200) comprising
at least one inner blade portion (210),

at least one outer blade portion (220), and
a connecting element (600) for connecting the inner blade portion
(210) and the outer blade portion (220),

wherein the inner blade portion (210) has a sleeve (216) at a first
5 end, which is achieved by winding of the inner blade portion (210),

wherein the at least one inner blade portion (210) and at least one
outer blade portion (220) are releasably fixed together so that the inner
blade portion (210) is fixed to the outer blade portion (220) by way of the
connecting element (600).

10

6. A wind turbine rotor blade according to claim 5

wherein the inner blade portion (210) has at least one first web
(250) which is glued in,

wherein the connecting element (600) is introduced into the sleeves
15 (216) of the inner blade portion with its first end (260) which has a second
web (650) which is glued in,

wherein the second end (620) of the connecting element (600) is
glued in a first end of an outer blade portion (220).

20

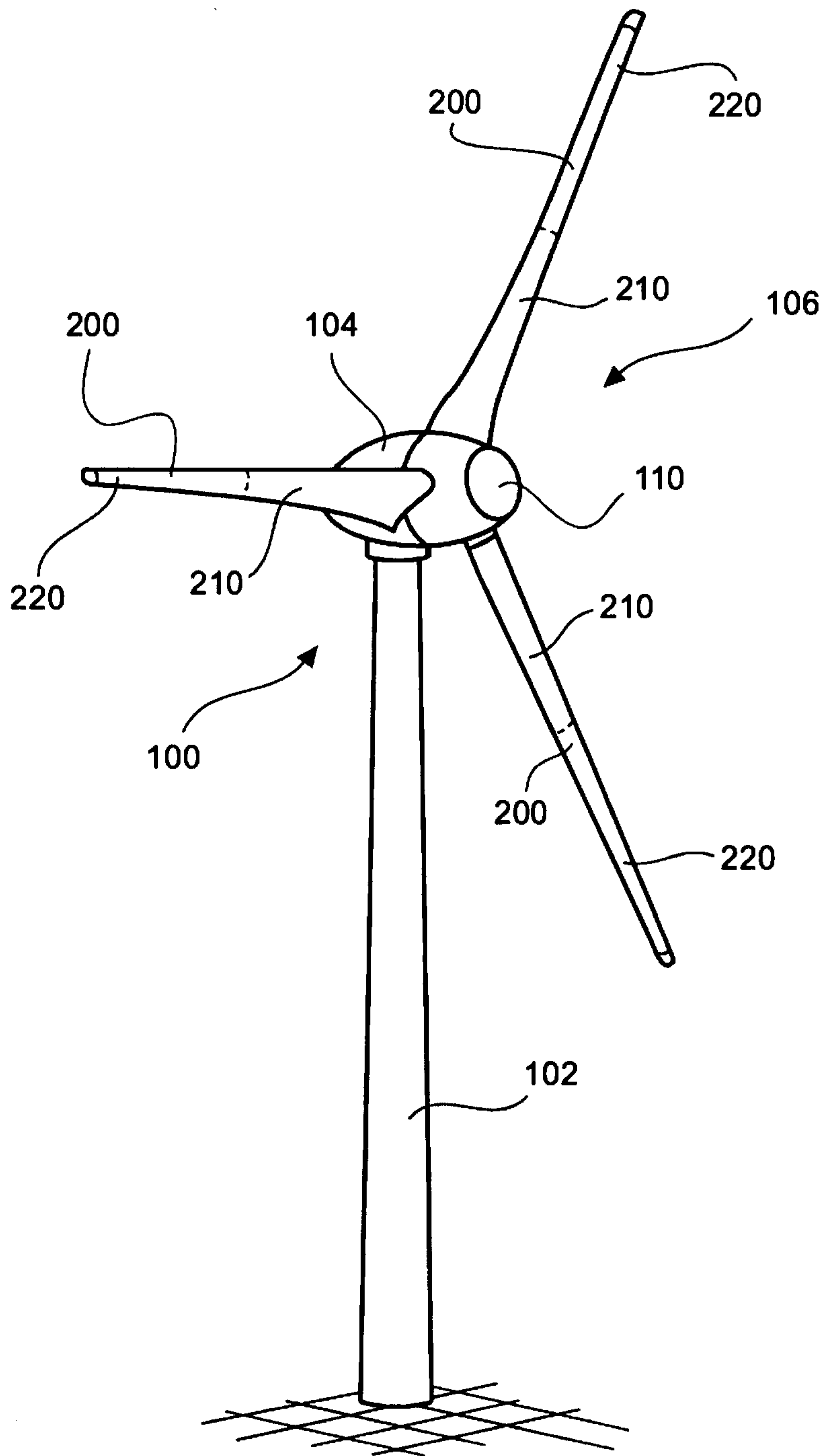

Fig. 1

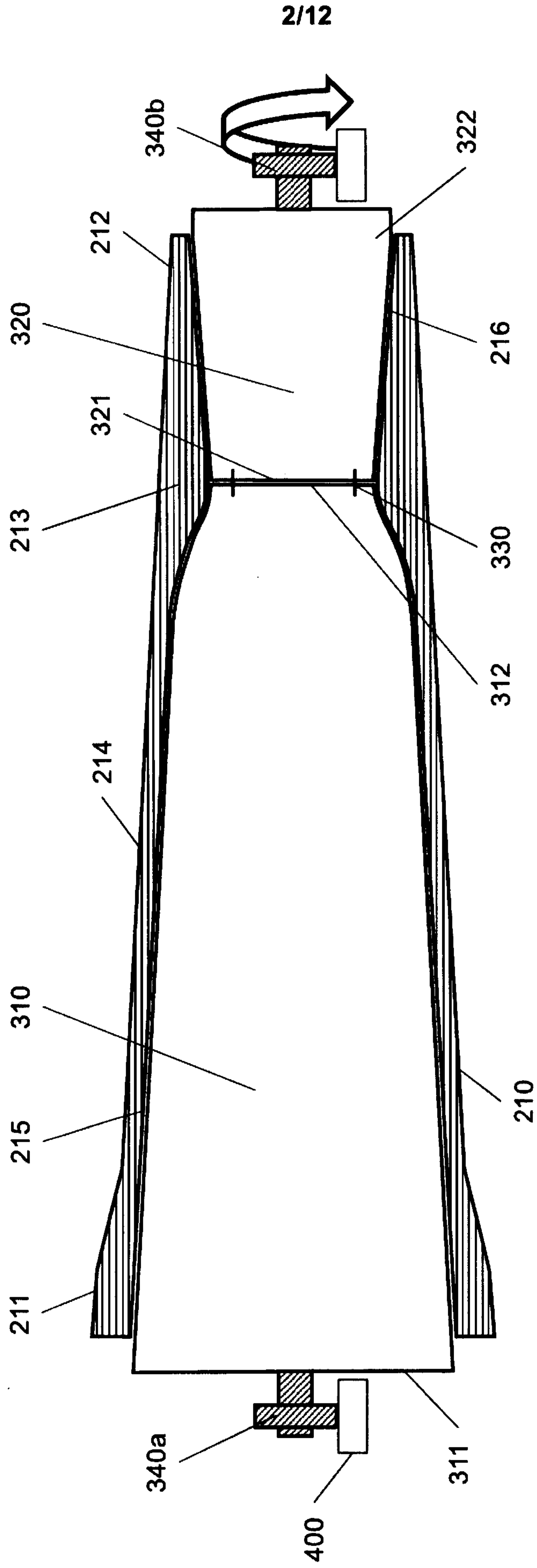

Fig. 2

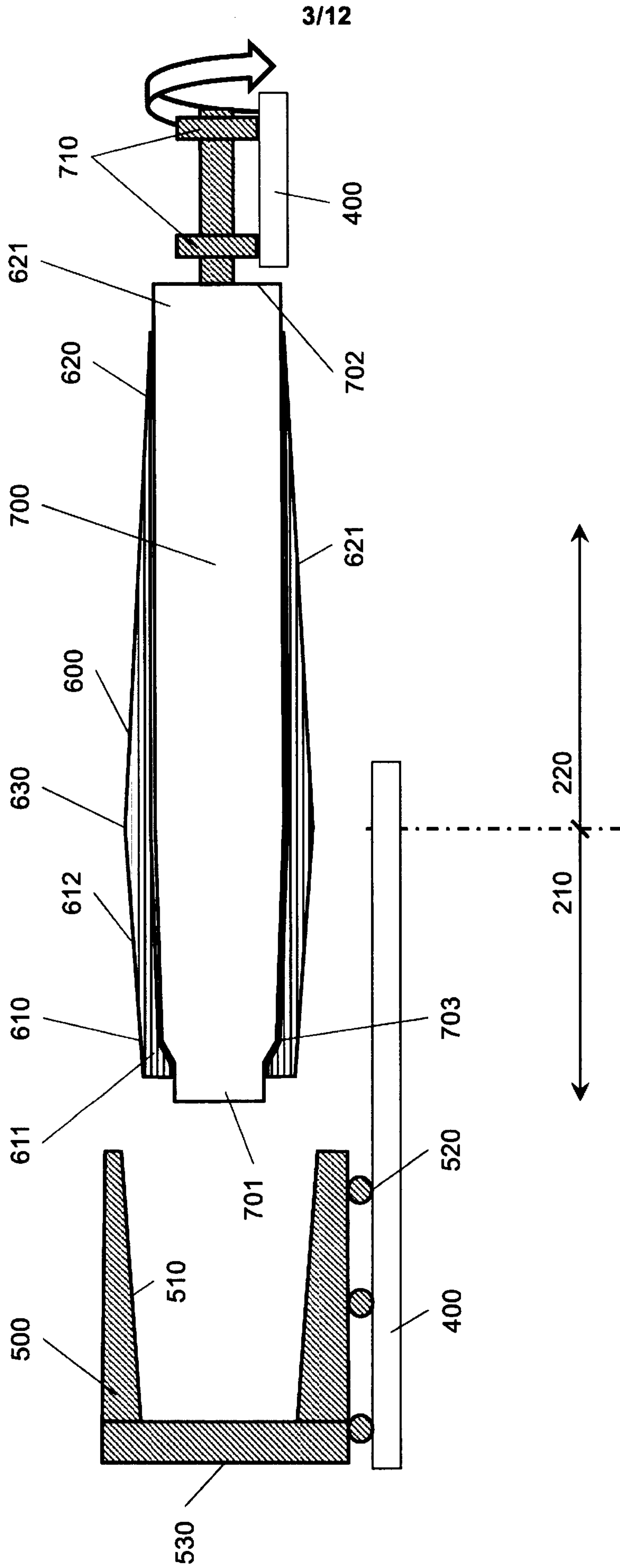

Fig. 3

4/12

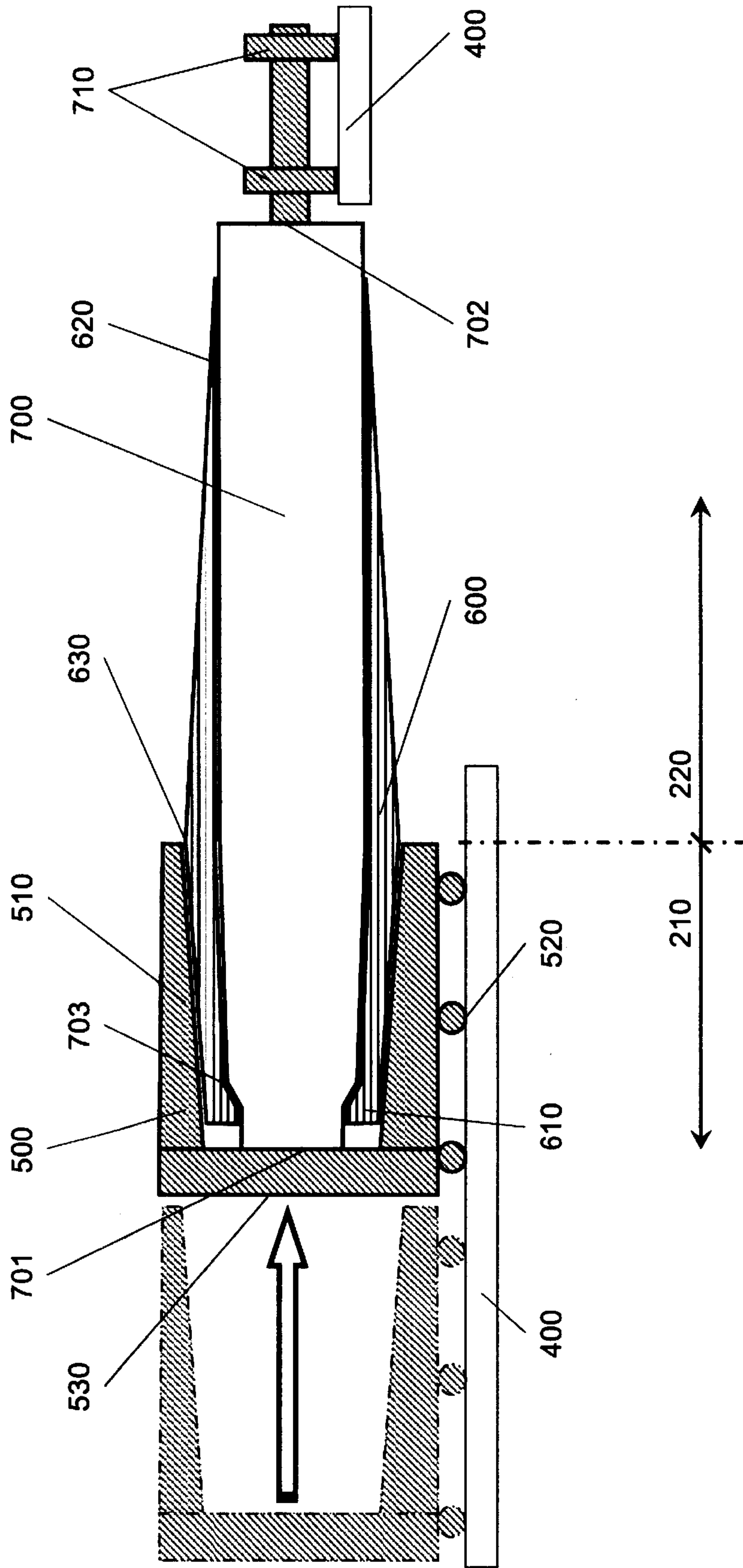

Fig. 4

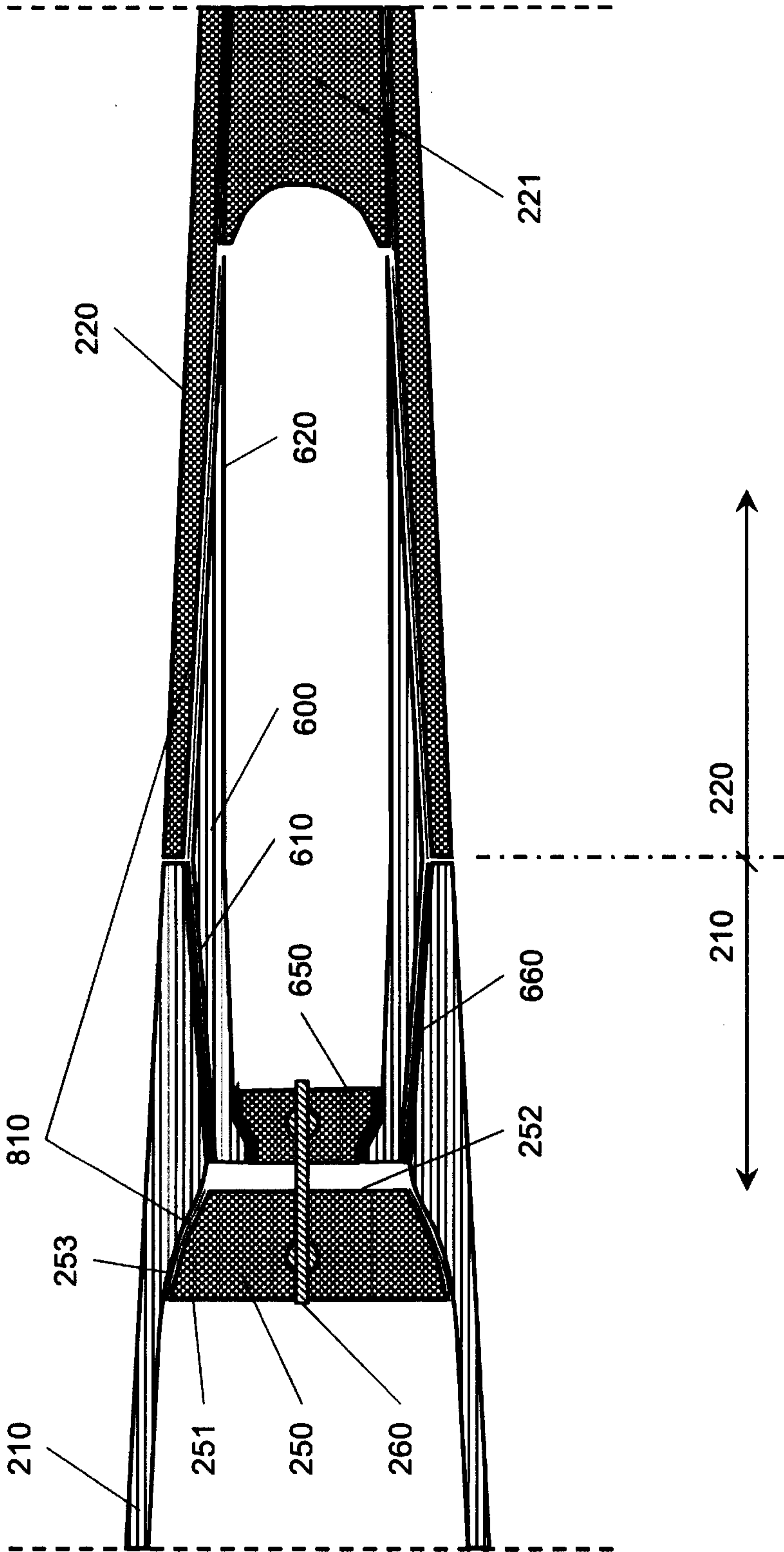

Fig. 5

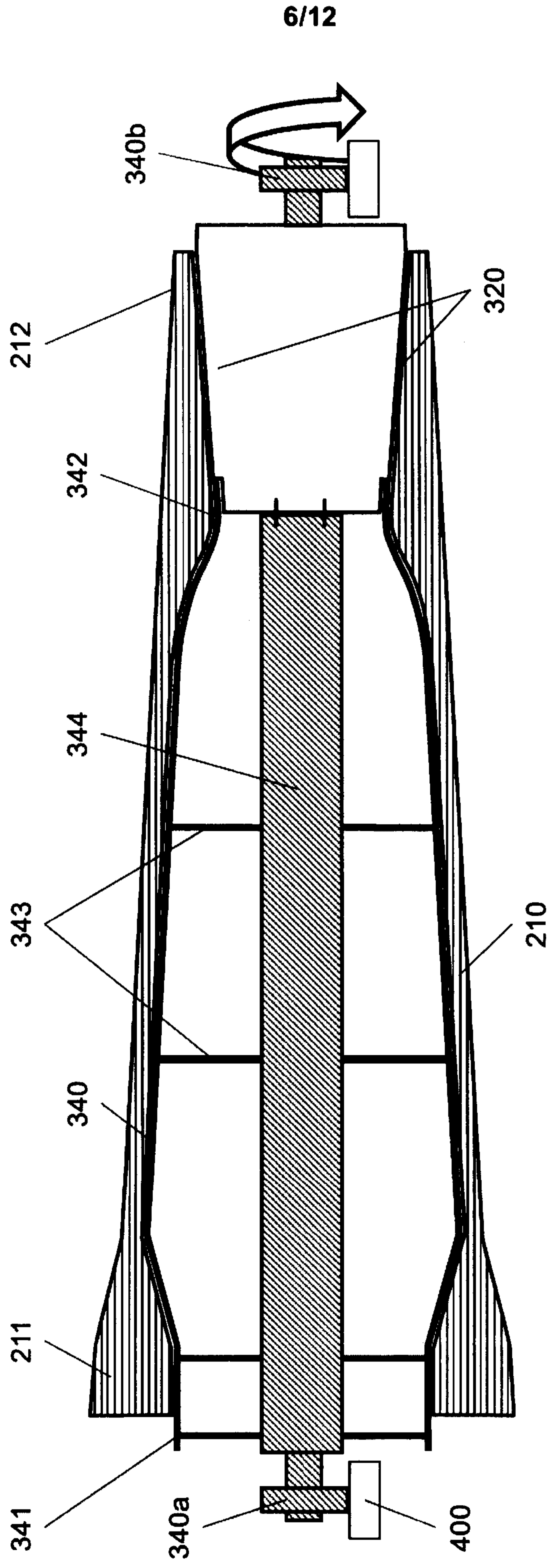

Fig. 6

7/12

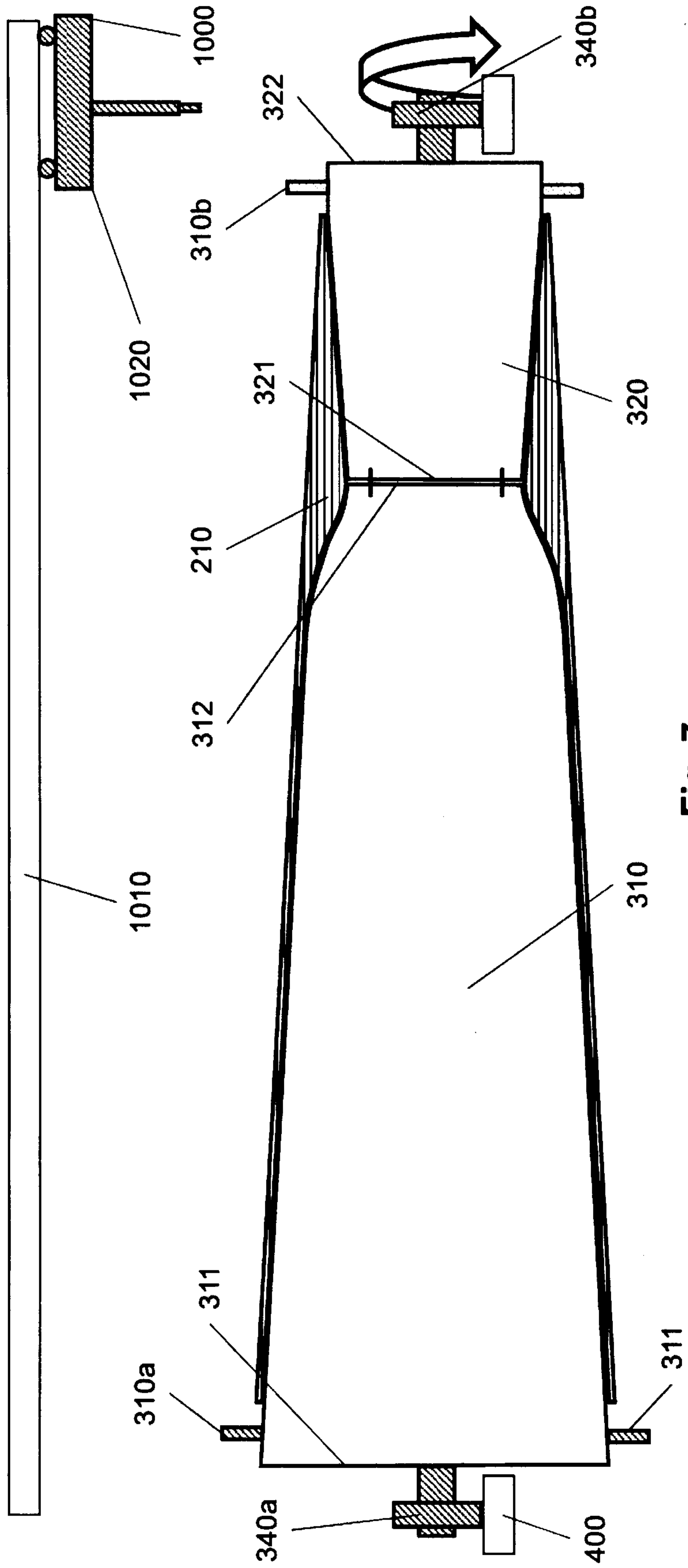

Fig. 7

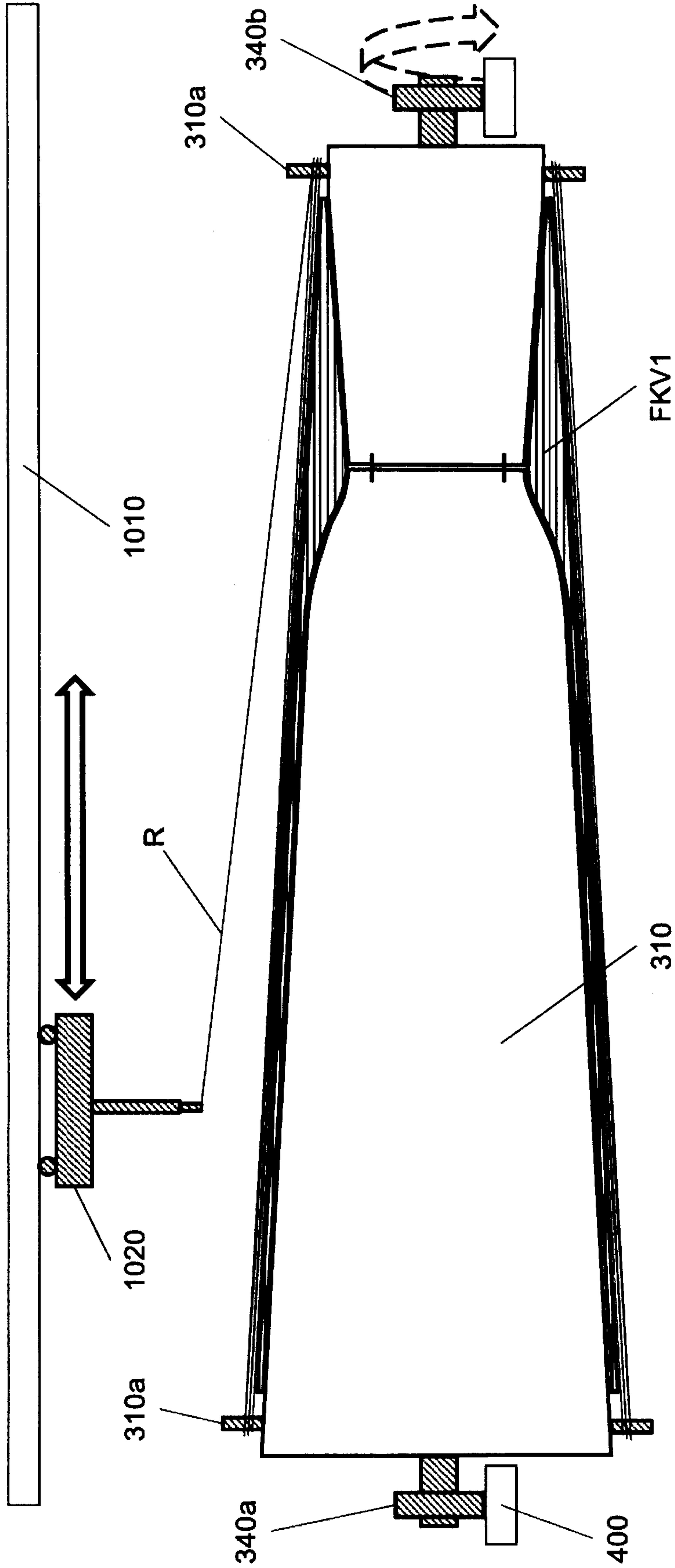

Fig. 8

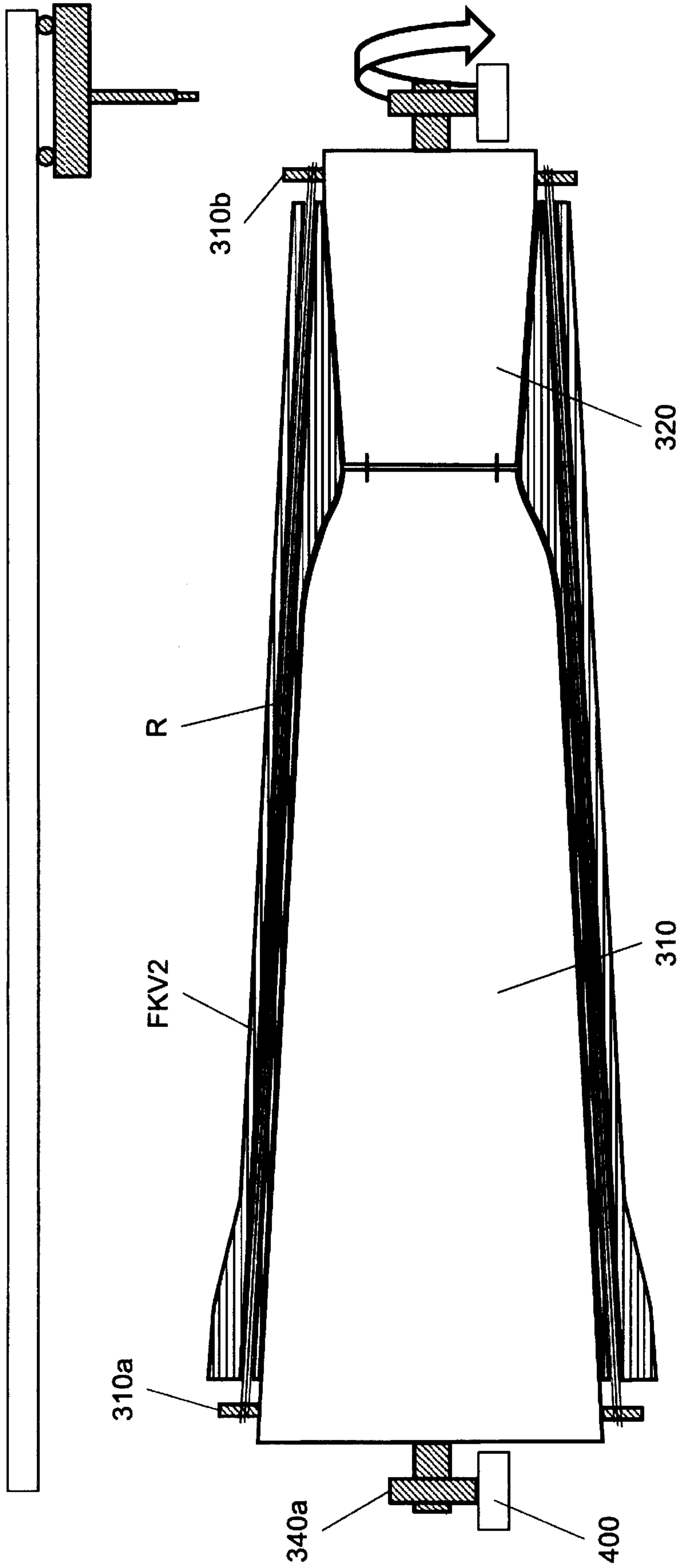

Fig. 9

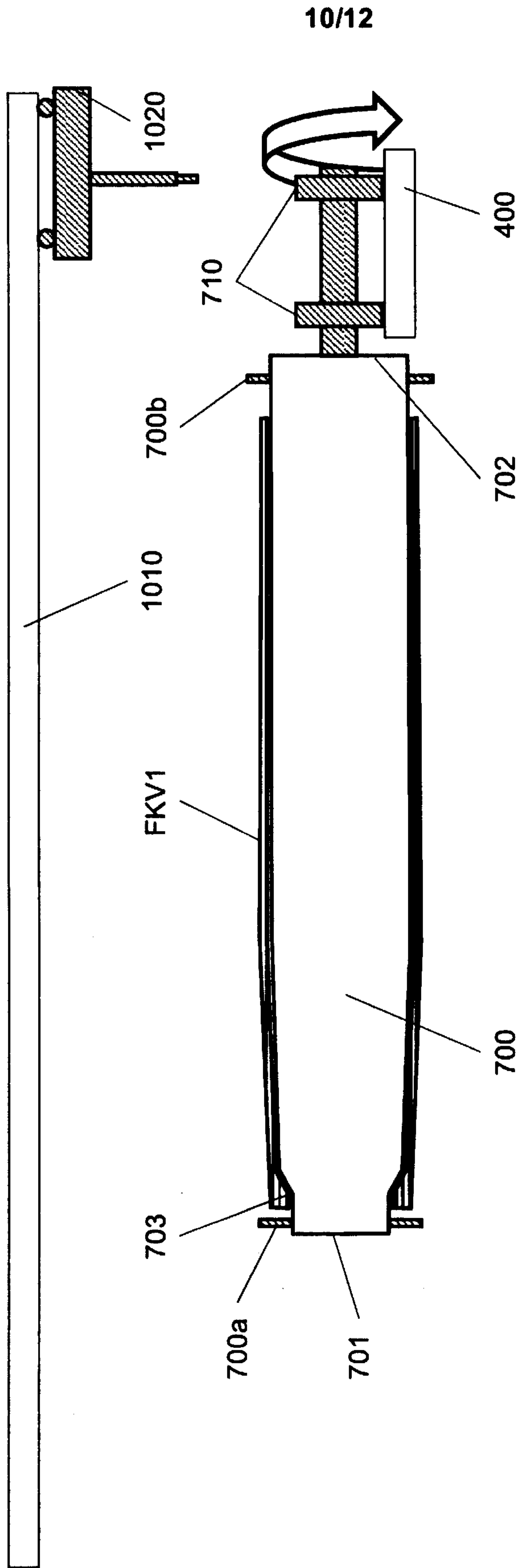

Fig. 10

11/12

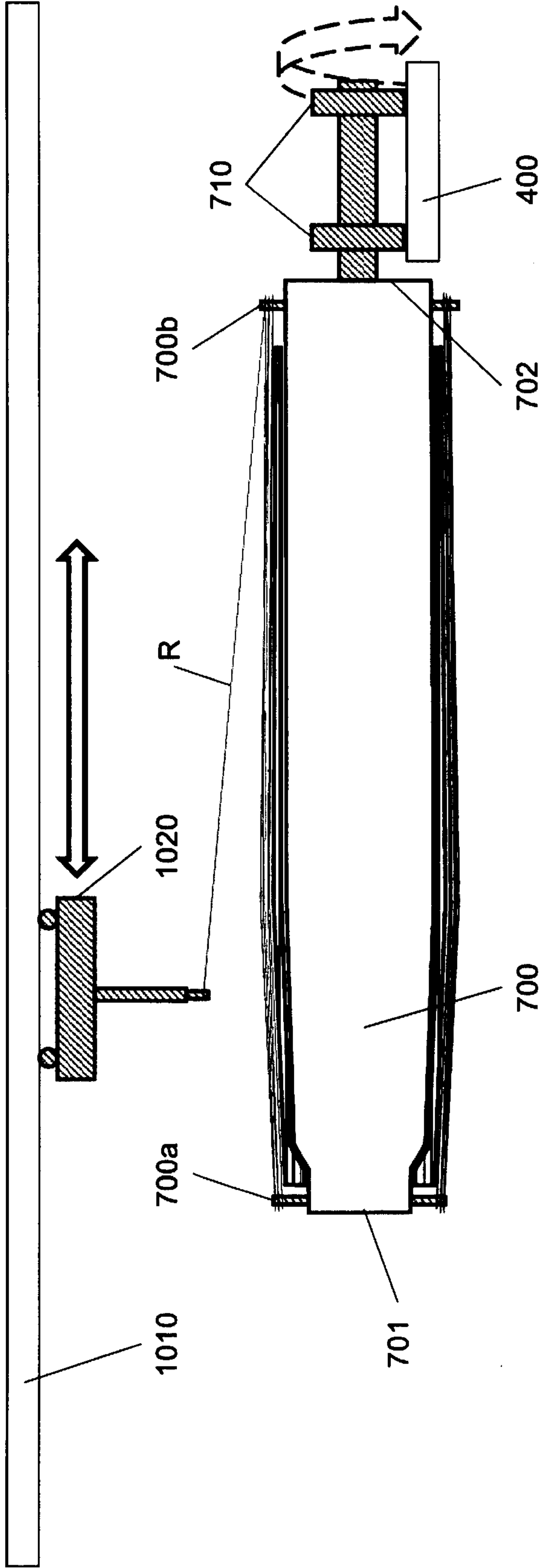

Fig. 11

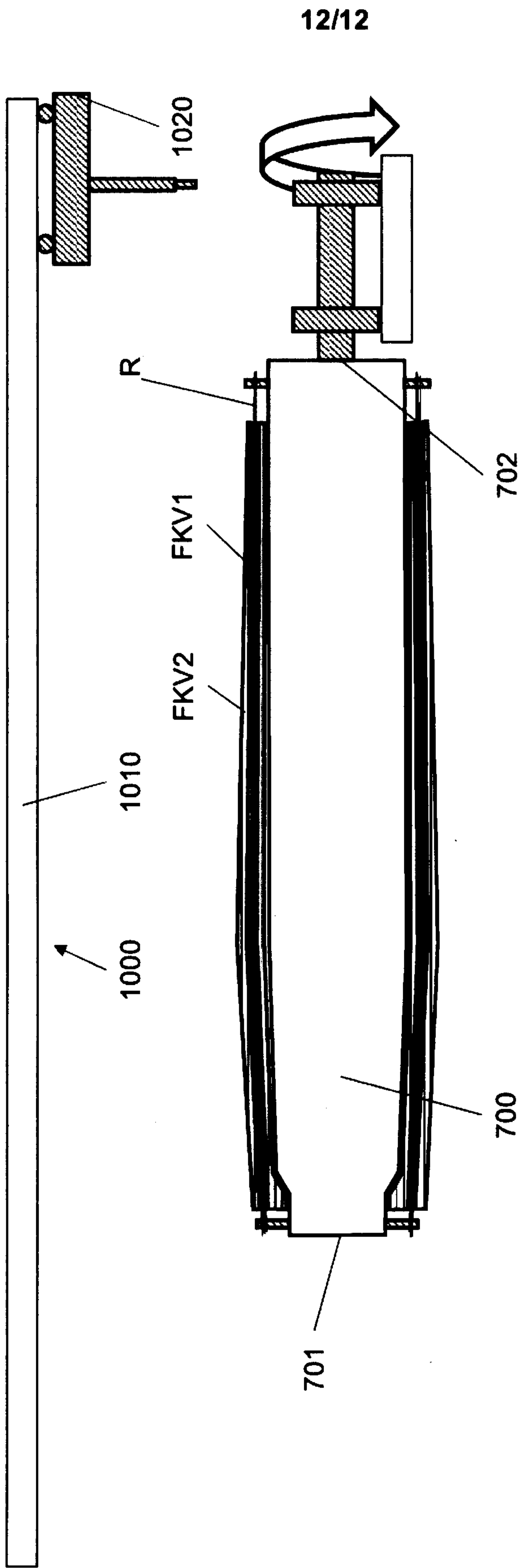

Fig. 12

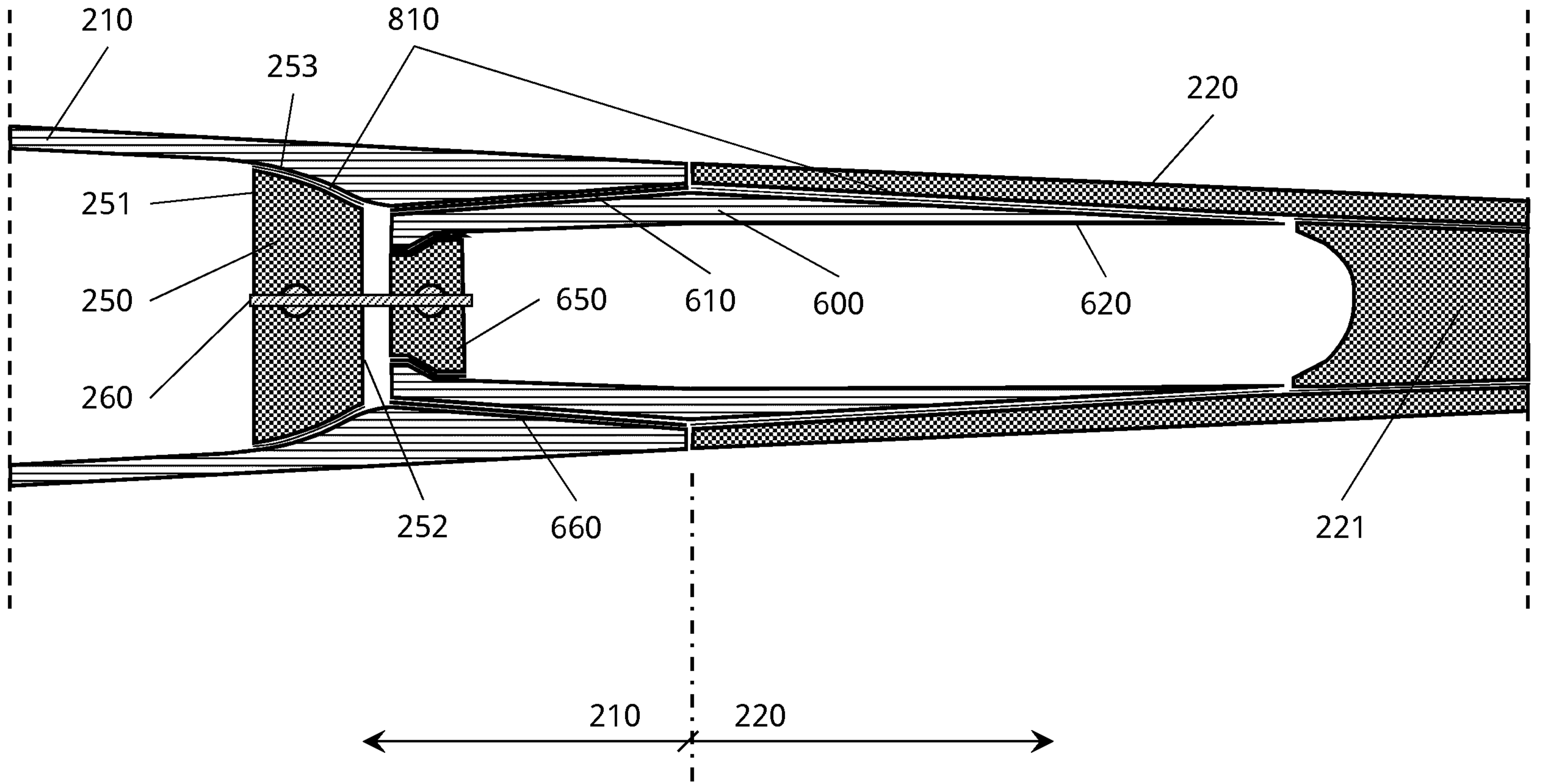

Fig. 5