

(19) World Intellectual Property Organization  
International Bureau



(43) International Publication Date  
13 November 2008 (13.11.2008)

PCT

(10) International Publication Number  
**WO 2008/135802 A1**

- (51) International Patent Classification:  
*H01Q 1/24* (2006.01)
  - (21) International Application Number:  
PCT/IB2007/001821
  - (22) International Filing Date: 2 May 2007 (02.05.2007)
  - (25) Filing Language: English
  - (26) Publication Language: English
  - (71) Applicant (for all designated States except US): **NOKIA CORPORATION** [FI/FI]; Keilalahdentie 4, FIN-02150 Espoo (FI).
  - (72) Inventor; and
  - (75) Inventor/Applicant (for US only): **BREITER, Richard** [DK/DK]; Bakkegaards Alle 9, 2 tv, DK-1804 Frederiksberg C (DK).
  - (74) Agents: **HIGGIN, Paul** et al.; Swindell & Person, 48 Friar Gate, Derby DE1 1GY (GB).
  - (81) Designated States (unless otherwise indicated, for every kind of national protection available): AE, AG, AL, AM, AT, AU, AZ, BA, BB, BG, BH, BR, BW, BY, BZ, CA, CH, CN, CO, CR, CU, CZ, DE, DK, DM, DZ, EC, EE, EG, ES, FI, GB, GD, GE, GH, GM, GT, HN, HR, HU, ID, IL, IN, IS, JP, KE, KG, KM, KN, KP, KR, KZ, LA, LC, LK, LR, LS, LT, LU, LY, MA, MD, MG, MK, MN, MW, MX, MY, MZ, NA, NG, NI, NO, NZ, OM, PG, PH, PL, PT, RO, RS, RU, SC, SD, SE, SG, SK, SL, SM, SV, SY, TJ, TM, TN, TR, TT, TZ, UA, UG, US, UZ, VC, VN, ZA, ZM, ZW.
  - (84) Designated States (unless otherwise indicated, for every kind of regional protection available): ARIPO (BW, GH, GM, KE, LS, MW, MZ, NA, SD, SL, SZ, TZ, UG, ZM, ZW), Eurasian (AM, AZ, BY, KG, KZ, MD, RU, TJ, TM), European (AT, BE, BG, CH, CY, CZ, DE, DK, EE, ES, FI, FR, GB, GR, HU, IE, IS, IT, LT, LU, LV, MC, MT, NL, PL, PT, RO, SE, SI, SK, TR), OAPI (BF, BJ, CF, CG, CI, CM, GA, GN, GQ, GW, ML, MR, NE, SN, TD, TG).
- Published:**  
— with international search report

(54) Title: AN ANTENNA ARRANGEMENT

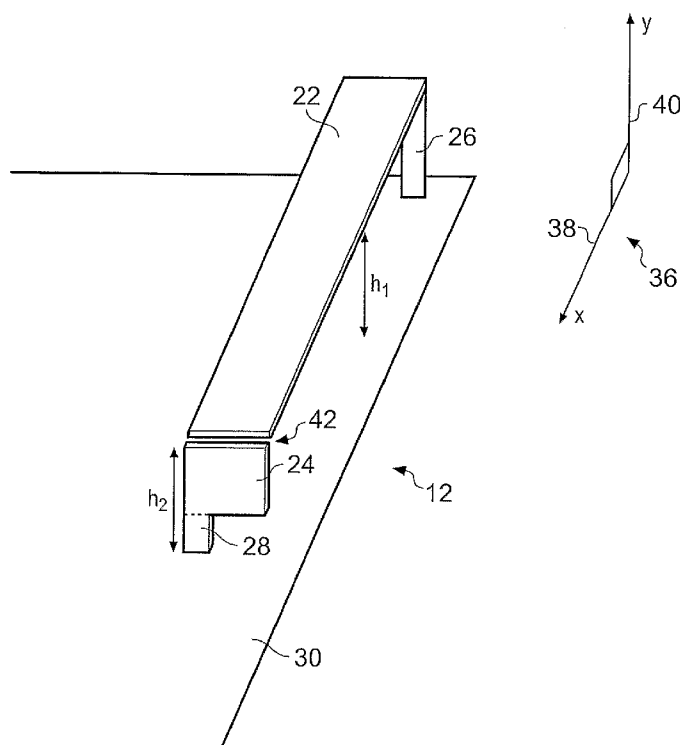

Fig. 2

(57) Abstract: An antenna arrangement comprising: a first element operable in a first resonant mode at a first resonant frequency band; and a second element arranged to couple with the first element to enable the first element to resonate in a second resonant mode having a second resonant frequency band, the second element having an impedance at the first resonant frequency band which substantially suppresses coupling between the first element and the second element.

WO 2008/135802 A1

## TITLE

An Antenna Arrangement

## 5 FIELD OF THE INVENTION

Embodiments of the present invention relate to an antenna arrangement. In particular, embodiments of the present invention relate to an antenna arrangement for a mobile cellular telephone.

10

## BACKGROUND TO THE INVENTION

In recent years, the number of radio frequency bands and protocols in which a wireless device (such as a mobile cellular telephone) may operate has increased and it has become desirable for such devices to be capable of operating in a plurality of these frequency bands and protocols. As a consequence of this, the volume of the antenna arrangements for such devices has correspondingly increased in order to isolate the antennas from one another to reduce interference.

20

However, there is also a desire in the industry to reduce the size of such devices. Consequently, the antenna arrangement for such a device may limit the extent to which the size of a device may be reduced and/or limit the number of other electronic components which may be housed within a device of a given size.

25

It would therefore be desirable to provide an alternative antenna arrangement.

## BRIEF DESCRIPTION OF THE INVENTION

30

According to one embodiment of the invention there is provided an antenna arrangement comprising: a first element operable in a first resonant mode at a first resonant frequency band; and a second element arranged to couple with

the first element to enable the antenna arrangement to resonate in a second resonant mode having a second resonant frequency band, the second element having an impedance at the first resonant frequency band which substantially suppresses coupling between the first element and the second element.

The antenna arrangement may further comprise a first matching circuit. The first matching circuit may be connected to the first element via a first feed point. The first matching circuit may have an impedance at the first resonant frequency band which enables the first element to operate in the first resonant frequency band.

The first matching circuit may have an impedance at the second resonant frequency band which substantially prevents the transmission and reception of signals therethrough. The first matching circuit may include a low pass filter.

The antenna arrangement may further comprise a second matching circuit. The second matching circuit may be connected to the second element via a second feed point. The second matching circuit may have an impedance at the first resonant frequency band which substantially prevents coupling between the first element and the second element.

The second matching circuit may have an impedance at the second resonant frequency band which enables the transmission and reception of signals therethrough. The second matching circuit may include a high pass filter.

The antenna arrangement may further comprise a ground plane. The second element may be oriented substantially perpendicular relative to the ground plane. The second element may be substantially planar relative to the ground plane.

3

The first element may include a first end and a second end, opposite to the first end. The first element may be connected to a feed point at the first end. The second element may be positioned adjacent the second end of the first element.

5

The second element may capacitively couple with first element.

According to another embodiment of the present invention, there is provided an apparatus comprising the antenna arrangement as described in the preceding paragraphs.

10

According to a further embodiment of the present invention, there is provided a mobile cellular telephone comprising the antenna arrangement as described in the preceding paragraphs.

15

According to some embodiments of the invention there is provided a method of manufacturing a wireless apparatus comprising: providing a first element that is a resonant antenna at a first frequency band and is connected to a feed for the first frequency band; providing a second element that is connected to a feed for a second frequency band and that has an impedance at the first frequency band which substantially suppresses coupling, and an impedance at the second frequency band which enables coupling; and positioning the first and second elements such that the second element couples with the first element to form an antenna arrangement that is resonant at the second frequency band.

20

25

According to one embodiment of the invention there is provided an antenna arrangement comprising: a first element that is resonant at a first frequency band and is connected to a first feed for the first frequency band; a second element that is connected to a second feed for a second frequency band and is arranged to couple with the first element to enable the antenna arrangement to resonate at the second resonant frequency band, the second

30

4

element having an impedance at the first frequency band which substantially suppresses coupling between the first element and the second element.

#### BRIEF DESCRIPTION OF THE DRAWINGS

5

For a better understanding of the present invention reference will now be made by way of example only to the accompanying drawings in which:

10 Fig. 1A illustrates a schematic diagram of an apparatus including an antenna arrangement according to one embodiment of the invention;

Fig. 1B illustrates a schematic diagram of an apparatus including an antenna arrangement according to another embodiment of the invention;

15 Fig. 2 illustrates a perspective diagram of an antenna arrangement according to an embodiment of the invention; and

Fig. 3 illustrates a perspective diagram of an antenna arrangement according to another embodiment of the invention;

20

Fig. 4 illustrates a perspective diagram of an antenna arrangement according to a further embodiment of the invention;

25 Fig. 5 illustrates a perspective diagram of an antenna arrangement according to another embodiment of the invention; and

Fig. 6 illustrates a perspective diagram of an antenna arrangement according to a further embodiment of the invention.

#### 30 DETAILED DESCRIPTION OF EMBODIMENTS OF THE INVENTION

The figures illustrate an antenna arrangement 12 comprising: a first element 22 operable in a first resonant mode at a first resonant frequency band; and a

5

second element 24 arranged to couple with the first element 22 to enable the antenna arrangement 12 to resonate in a second resonant mode having a second resonant frequency band, the second element 24 having an impedance at the first resonant frequency band which substantially suppresses coupling between the first element 22 and the second element 24.

In more detail, Fig. 1A illustrates an apparatus 10 such as a portable electronic device (for example, a mobile cellular telephone or a personal digital assistant), a cellular base station, other radio communication device or module for such devices.

The apparatus 10 comprises an antenna arrangement 12, a first matching circuit 14, a second matching circuit 16, a transceiver 18 and functional circuitry 20. The antenna arrangement 12 includes a first element 22 and a second element 24. The first matching circuit 14 is connected to the first element 22 via a first feed point 26 and is also connected to a first RF port 21 of the transceiver 18. The second matching circuit 16 is connected to the second element 24 via a second feed point 28 and is also connected to a second RF port 23 of the transceiver 18. The functional circuitry 20 is connected to the transceiver 18 and is operable to provide signals to, and receive signals from the transceiver 18.

In the embodiment where the apparatus 10 is a mobile cellular telephone, the functional circuitry 20 may include a processor, a memory and input/output devices such as a microphone, a loudspeaker and a display. The electronic components that provide the first matching circuit 14, the second matching circuit 16, the transceiver 18 and the functional circuitry 20 are interconnected via a printed wiring board (PWB) 30. In various embodiments the PWB 30 may be used as a ground plane for the antenna arrangement 12. In other embodiments, the antenna arrangement 12 may not have a ground plane.

The first element 22 is an antenna element which is operable to resonate in a first resonant mode at a first resonant frequency band. In various

6

embodiments, the first element 22 is a multi-band antenna element and operable in a plurality of resonant frequency bands. The first element 22 may be any suitable antenna and may be for example, a PIFA antenna, a PILA antenna, a loop antenna or a helical antenna.

5

The functional circuitry 20 is operable to provide signals to and/or receive signals from the first element 22 via the transceiver 18, first matching circuit 14 and the first feed point 26. The first matching circuit 14 is arranged such that the first element 22 has an impedance at the first resonant frequency band which enables it to operate at that frequency band (it may have an impedance of 50 ohms at the first resonant frequency band for example). The first matching circuit 14 is also arranged such that it has an impedance (substantially different to 50 ohms for example) at a second resonant frequency band (different to the first resonant frequency band) which substantially prevents the transmission and reception of signals having a frequency within the second resonant frequency band through the first matching circuit 14.

In an embodiment where the first resonant frequency band is lower in frequency than the second resonant frequency band, the first matching circuit 14 may include a low pass filter 32 which is arranged to block frequencies greater than the first resonant frequency band.

The second element 24 is arranged in the antenna arrangement 12 such that it capacitively couples with the first element 22 to enable the antenna arrangement 12 (i.e. the first element 22 and the second element 24 in this embodiment) to resonate in a second resonant mode having a second resonant frequency band. The second element 24 in isolation (i.e. without the first element 22) is unable to transmit and receive signals in the first resonant frequency band or the second resonant frequency band.

The second matching circuit 16 is arranged such that the second element 24 has an impedance (which may be 50 ohms for example) at the second

7

resonant frequency band which enables the second element 24 to capacitively couple with the first element 22. Additionally, the impedance of the second matching circuit 16 enables the transmission and reception of signals within the second resonant frequency band through the second  
5 matching circuit 16.

The second matching circuit 16 is also arranged such that the second element 24 has an impedance (substantially different to 50 ohms for example) at the first resonant frequency band which substantially prevents the second  
10 element from coupling with the first element 22. In the embodiment where the first resonant frequency band is lower in frequency than the second resonant frequency band, the second matching circuit may include a high pass filter 34 which is arranged to block frequencies which are lower than the second resonant frequency band.

15

Embodiments of the present invention provide an advantage in that the coupling with the second element 24 enables the first element 22 to operate in its second resonant mode and thereby provide an additional resonant frequency band. Additionally, since the second element 24 has an impedance  
20 at the first resonant frequency band which substantially suppresses coupling between the first element 22 and the second element 24, the second element 22 does not affect the performance of the first element 22 when the first element 22 is operating in the first resonant frequency band.

25 Fig. 1B illustrates a schematic diagram of an apparatus 10 including an antenna arrangement 12 according to another embodiment of the invention. The apparatus 10 is similar to the apparatus illustrated in Fig. 1A and where the features are similar, the same reference numerals are used.

30 The apparatus illustrated in Fig. 1B differs from the apparatus illustrated in Fig. 1A in that it comprises a first transceiver 18<sub>1</sub> connected to the first matching circuit 14 and to the functional circuitry 20, and a second transceiver 18<sub>2</sub> connected to the second matching circuit 16 and to the functional circuitry

20. The first transceiver  $18_1$  and the second transceiver  $18_2$  may be in the same integrated circuit package or in different integrated circuit packages.

5 The first transceiver  $18_1$  operates according to a different radio communication protocol to the second transceiver  $18_2$ . For example, the first transceiver  $18_1$  may be for cellular communications (e.g. GSM) whereas the second transceiver  $18_2$  may be for GPS.

10 Fig. 2 illustrates a perspective diagram of an antenna arrangement 12 according to one embodiment of the invention. A Cartesian coordinate system 36 is provided in the figure which has an X axis 38 and a Y axis 40 which are orthogonal with respect to one another.

15 The first element 22 is a Planar Inverted L Antenna which extends from the first feed point 26 in the +X direction until its end point 42. The first element 22 is planar with respect to the ground plane 30 and has a height  $h_1$  above the ground plane 30 measured in the +Y direction.

20 The second element 24 extends from the second feed point 28 in the +Y direction to a height  $h_2$  and is therefore oriented perpendicularly relative to the ground plane 30. In this embodiment, the height of the second element  $h_2$  is substantially equal to the height  $h_1$  of the first element 24.

25 The second element 24 is positioned adjacent the end 42 of the first element 22. When the first element 22 is operating, the electric field E of the first element 22 is at its maximum at the end 42. Consequently, one advantage of positioning the second element 24 adjacent the end 42 of the first element 22 is that the capacitive coupling between the elements 22 and 24 is maximised.

30 Another advantage provided by the antenna arrangement 12 illustrated in Fig. 2 is that it occupies a relatively low volume. Since the second element 24 is oriented perpendicular to the ground plane 30 and the first element 22 and does not extend beyond the height  $h_1$  of the first element 22, it occupies very

little volume. Consequently, an additional resonant mode may be excited in the first element 22 with little extra volume required for the antenna arrangement 12.

5 Fig. 3 illustrates a perspective diagram of an antenna arrangement 12 according to another embodiment of the invention. The embodiment illustrated in Fig. 3 is similar to the embodiment illustrated in Fig. 2 and where the features are similar, the same reference numerals are used.

10 The embodiment illustrated in Fig. 3 differs from the embodiment illustrated in Fig. 2 in that the second element 24 extends from the second feed point 28 in the  $-X$  direction until its end point 44 and is generally planar with respect to the ground plane 30 and may be coplanar with the first element 22. The end point 44 of the second element 24 is positioned adjacent the end 42 of the  
15 first element 22.

Fig. 4 illustrates a perspective diagram of antenna arrangement 12 according to a further embodiment of the invention. The embodiment illustrated in Fig. 4 is similar to the embodiment illustrated in Figs. 2 and where the features are  
20 similar, the same reference numerals are used.

It should be appreciated that the Cartesian coordinate system 36 illustrated in Fig. 4 also has a Z axis 45 which is orthogonal to the x axis 38 and to the y axis 40.

25

The embodiment illustrated in Fig. 4 differs from the embodiment illustrated in Fig. 2 in that the second element 24 is positioned adjacent a side 46 of the first element 22 and proximal to the end 42 of the first element 22. In the illustrated embodiment, the side 46 of the first element 22 is the side of the  
30 first element 22 which has the highest positive z axis value.

Fig. 5 illustrates a perspective diagram of an antenna arrangement 12 according to another embodiment of the invention. The embodiment

illustrated in Fig. 5 is similar to the embodiment illustrated in Fig. 4 and where the features are similar, the same reference numerals are used.

The embodiment illustrated in Fig. 5 differs from the embodiment illustrated in Fig. 4 in that the second element 24 extends from the second feed point 28 in the  $-Z$  direction until its end point 44 and is generally planar with respect to the ground plane 30 and may be coplanar with the first element 22. The end point 44 of the second element 24 is positioned adjacent the side 46 of the first element 22 and proximal to the end 42 of the first element 22.

It should be appreciated that the embodiments illustrated in Figs. 2, 3, 4 and 5 provide examples of how the first element 22 and the second element 24 may be arranged. In other embodiments of the invention, the first element 22 and the second element 24 may have alternative arrangements which provide coupling between the first element 22 and the second element 24.

Fig. 6 illustrates a perspective diagram of an antenna arrangement 12 according to a further embodiment of the invention. The embodiment illustrated in Fig. 6 is similar to the embodiment illustrated in Fig. 2 and where the features are similar, the same reference numerals are used.

It should be appreciated that the Cartesian coordinate system 36 illustrated in Fig. 6 also has a Z axis 45 which is orthogonal to the x axis 38 and to the y axis 40.

The embodiment illustrated in Fig. 6 differs from the embodiment illustrated in Fig. 2 in that the first element 22 is an L-shaped PILA. The first element 22 has a first portion 48 which extends from the feed point 26 in the  $+X$  direction until an end 42 and a second portion 50 which extends from the feed point 26 in the  $+Z$  direction until an end 52.

The first portion 48 and the second portion 50 of the first element 22 have different electrical lengths which allow them to resonate in different resonant

frequency bands. For example, in the illustrated embodiment, the first portion 48 has a smaller electrical length than the second portion 50. Consequently, the first portion 48 resonates in a higher frequency band (e.g. GPS 1575.42 MHz) than the second portion 50 (e.g. GSM900).

5

The second element 24 is positioned adjacent the end 42 of the first portion 48 of the first element 22. The second element 24 is arranged to couple with the first portion 48 and cause it to resonate in its resonant frequency band. The first feed point 26 causes the second portion 50 to resonate in its resonant frequency band.

10

This embodiment provides an advantage in that the two resonant modes of the first element 22 can be tuned independently of one another by changing the lengths of the first portion 48 and the second portion 50.

15

Additionally, the same structure may be used to provide the first resonant mode and the second mode, i.e. the two feed points 26 and 28 excite different modes in the same structure since the first feed point 26 excites one mode (e.g. GSM900 mode) and the second feed point 28 excites another mode (e.g. GPS mode).

20

In one embodiment (with respect to Figs. 1B, 2, 3, 4, 5 and 6), the first resonant frequency band is GSM 900 MHz and the second resonant frequency band is GPS 1.5 GHz. However, it should be appreciated that embodiments of the present invention are not limited to these frequency bands and protocols and may use any radio frequency band or protocol. For example, the different frequency bands and protocols may include (but are not limited to) DVB-H 470 to 702 MHz, US-GSM 850 (824-894 MHz); EGSM 900 (880-960MHz); GPS 1575.42 MHz, PCN/DCS1800 (1710-1880 MHz); US-WCDMA1900 (1850-1990) band; WCDMA2100 band (Tx: 1920-1980I Rx: 2110-2180); PCS1900 (1850-1990 MHz); 2.5 GHz WLAN/BT, 5 GHz WLAN, DRM (0.15 – 30.0 MHz), FM (76 – 108 MHz), AM (0.535 – 1.705 MHz), DVB – H [US] (1670 – 1675 MHz), WiMax (2300 – 2400 MHz, 2305 – 2360 MHz,

25

30

12

2496 – 2690 MHz, 3300 – 3400 MHz, 3400 – 3800 MHz, 5150 – 5875 MHz), RFID (LF [125-134kHz], HF[13.56MHz]) UHF [433MHz, 865 – 956 MHz or 2.45GHz), and UWB 3.0 to 10.6 GHz.

5 Although embodiments of the present invention have been described in the preceding paragraphs with reference to various examples, it should be appreciated that modifications to the examples given can be made without departing from the scope of the invention as claimed. For example, the first matching circuit 14 may include a diplexer connected to a matching circuit for  
10 the first resonant frequency band and connected to another matching circuit for the second resonant frequency band.

A lumped capacitor may be connected to the ends of the first element 22 and the second element 24 (e.g. between the ends 42 and 44 illustrated in Fig. 3)  
15 to improve the coupling between the first element 22 and the second element 24.

High permittivity material may be provided between the ends of the first element 22 and the second element 24 (e.g. between the ends 42 and 44  
20 illustrated in Fig. 3). This may provide an advantage in that it may allow the gap between the ends 42 & 44 of the first element 22 and second element 24 respectively to be increased which may make the antenna arrangement 12 less sensitive to production tolerances and therefore easier to construct.

25 The embodiments illustrated in Figs. 3 and 5 may be adapted so that the height  $h_2$  of the second element 24 is less than the height  $h_1$  of the first element 22 and so that the second element 24 at least partly extends under the first element 22. This arrangement may improve the coupling between the first element 22 and the second element 24.

30

It should be appreciated that an antenna arrangement 12 may comprise a plurality of second elements 24 for providing the same function and advantages as described above. Furthermore, more than one second

13

element 24 may be provided for coupling to a resonant element such as the first element 22.

5 Whilst endeavoring in the foregoing specification to draw attention to those features of the invention believed to be of particular importance it should be understood that the Applicant claims protection in respect of any patentable feature or combination of features hereinbefore referred to and/or shown in the drawings whether or not particular emphasis has been placed thereon.

10 I/we claim:

## CLAIMS

1. An antenna arrangement comprising:
  - 5 a first element operable in a first resonant mode at a first resonant frequency band; and
  - 10 a second element arranged to couple with the first element to enable the antenna arrangement to resonate in a second resonant mode having a second resonant frequency band, the second element having an impedance at the first resonant frequency band which substantially suppresses coupling between the first element and the second element.
  
- 15 2. An antenna arrangement as claimed in claim 1, further comprising a first matching circuit, connected to the first element via a first feed point, having an impedance at the first resonant frequency band which enables the first element to operate in the first resonant frequency band.
  
- 20 3. An antenna arrangement as claimed in claim 2, wherein the first matching circuit has an impedance at the second resonant frequency band which substantially prevents the transmission and reception of signals therethrough.
  
4. An antenna arrangement as claimed in claim 3, wherein the first matching circuit includes a low pass filter.
  
- 25 5. An antenna arrangement as claimed in any of the preceding claims, further comprising a second matching circuit, connected to the second element via a second feed point, having an impedance at the first resonant frequency band which substantially prevents coupling between the first element and the second element.
  
- 30 6. An antenna arrangement as claimed in claim 5, wherein the second matching circuit has an impedance at the second resonant frequency band which enables the transmission and reception of signals therethrough.

7. An antenna arrangement as claimed in claim 6, wherein the second matching circuit includes a high pass filter.
- 5 8. An antenna arrangement as claimed in any of the preceding claims, further comprising a ground plane, wherein the second element is oriented substantially perpendicular relative to the ground plane.
9. An antenna arrangement as claimed in any of claims 1 to 7, further  
10 comprising a ground plane, wherein the second element is substantially planar relative to the ground plane.
10. An antenna arrangement as claimed in any of the preceding claims, wherein the first element includes a first end and a second end, opposite to  
15 the first end, the first element being connected to a feed point at the first end and the second element being positioned adjacent the second end of the first element.
11. An antenna arrangement as claimed in any of the preceding claims,  
20 wherein the second element capacitively couples with first element.
12. An apparatus comprising the antenna arrangement as claimed in any of the preceding claims.
- 25 13. A module for a wireless device comprising the antenna arrangement as claimed in any one of claims 1 to 11.
14. A method of manufacturing a wireless apparatus comprising:  
providing a first element that is a resonant antenna at a first frequency  
30 band and is connected to a feed for the first frequency band;  
providing a second element that is connected to a feed for a second frequency band and that has an impedance at the first frequency band which

16

substantially suppresses coupling, and an impedance at the second frequency band which enables coupling; and

5 positioning the first and second elements such that the second element couples with the first element to form an antenna arrangement that is resonant at the second frequency band.

15. An antenna arrangement comprising:

a first element that is resonant at a first frequency band and is connected to a first feed for the first frequency band;

10 a second element that is connected to a second feed for a second frequency band and is arranged to couple with the first element to enable the antenna arrangement to resonate at the second resonant frequency band, the second element having an impedance at the first frequency band which substantially suppresses coupling between the first element and the second element.

15

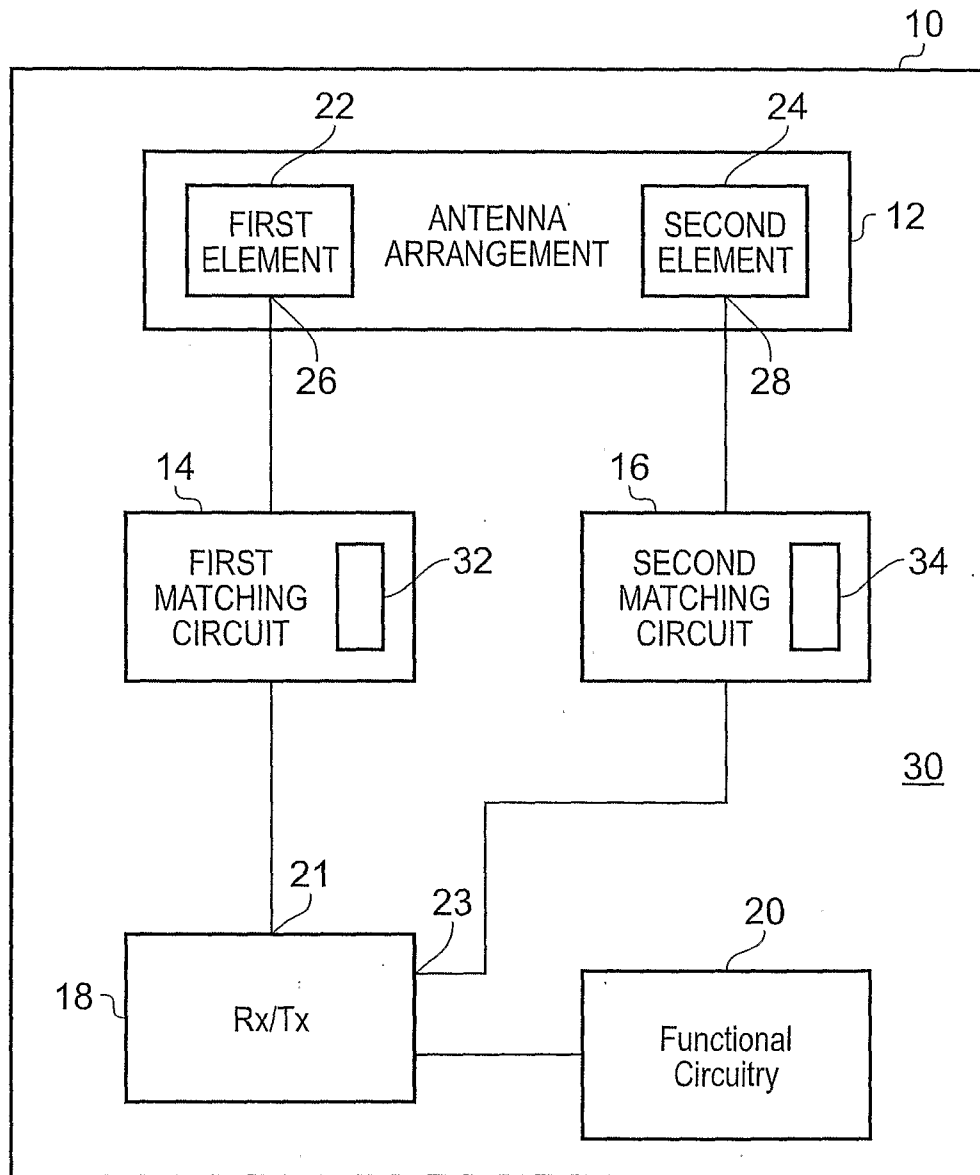

Fig. 1A

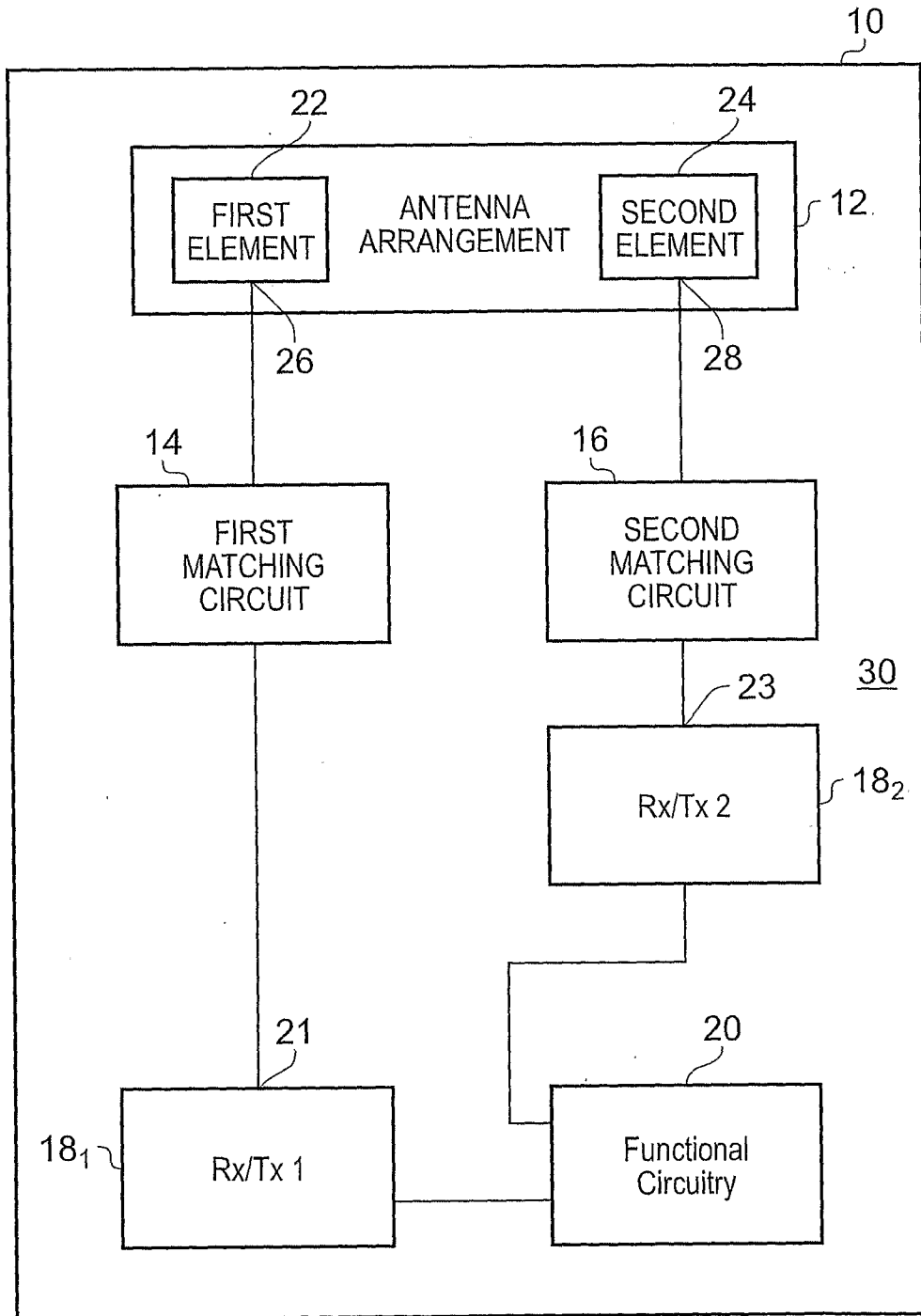

Fig. 1B

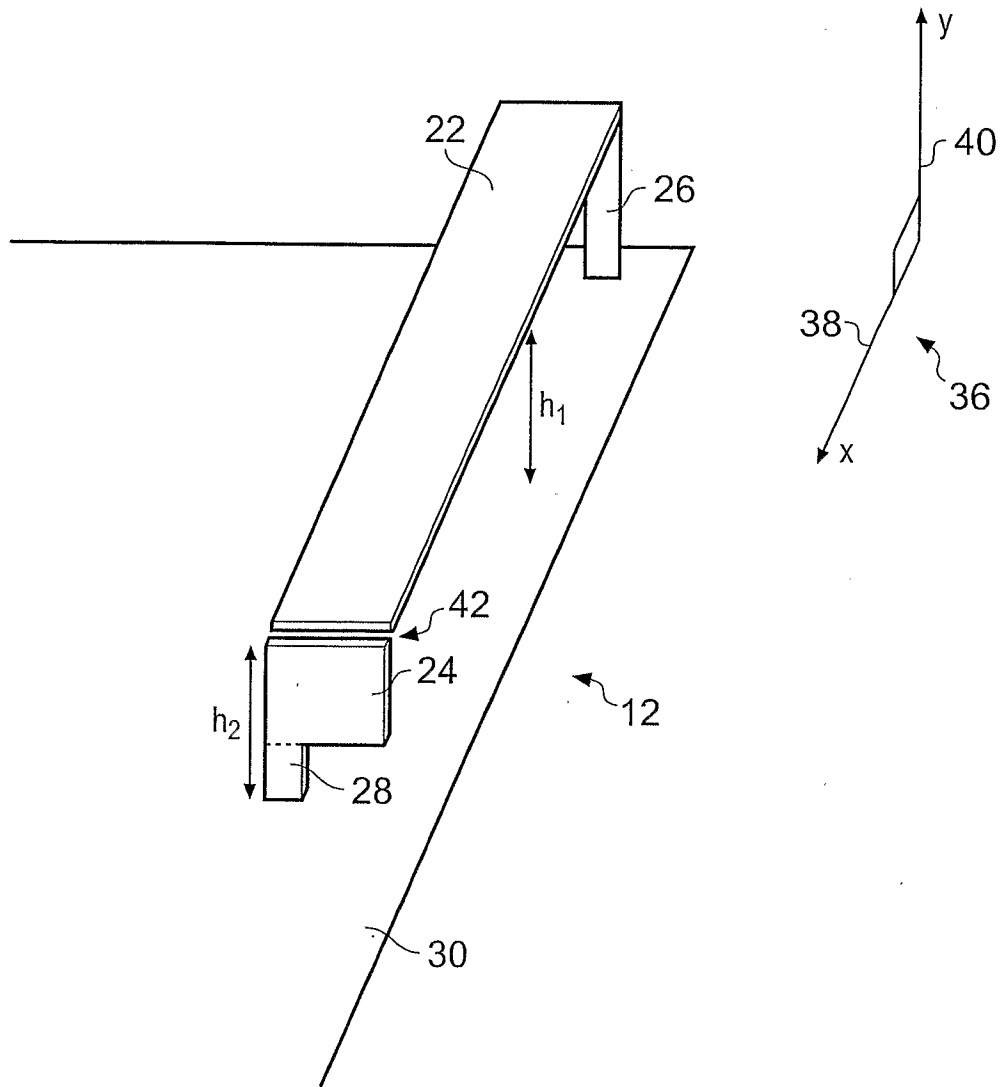

Fig. 2

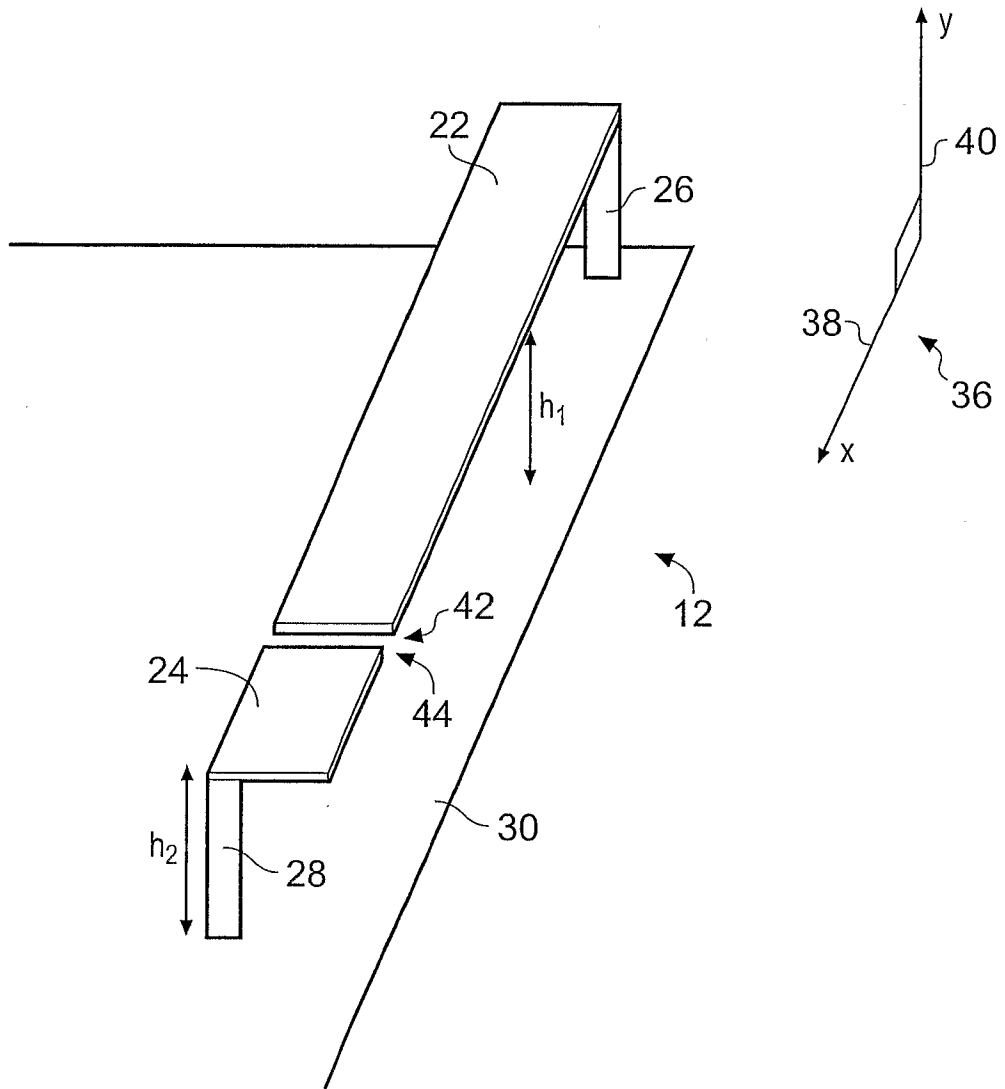

Fig. 3

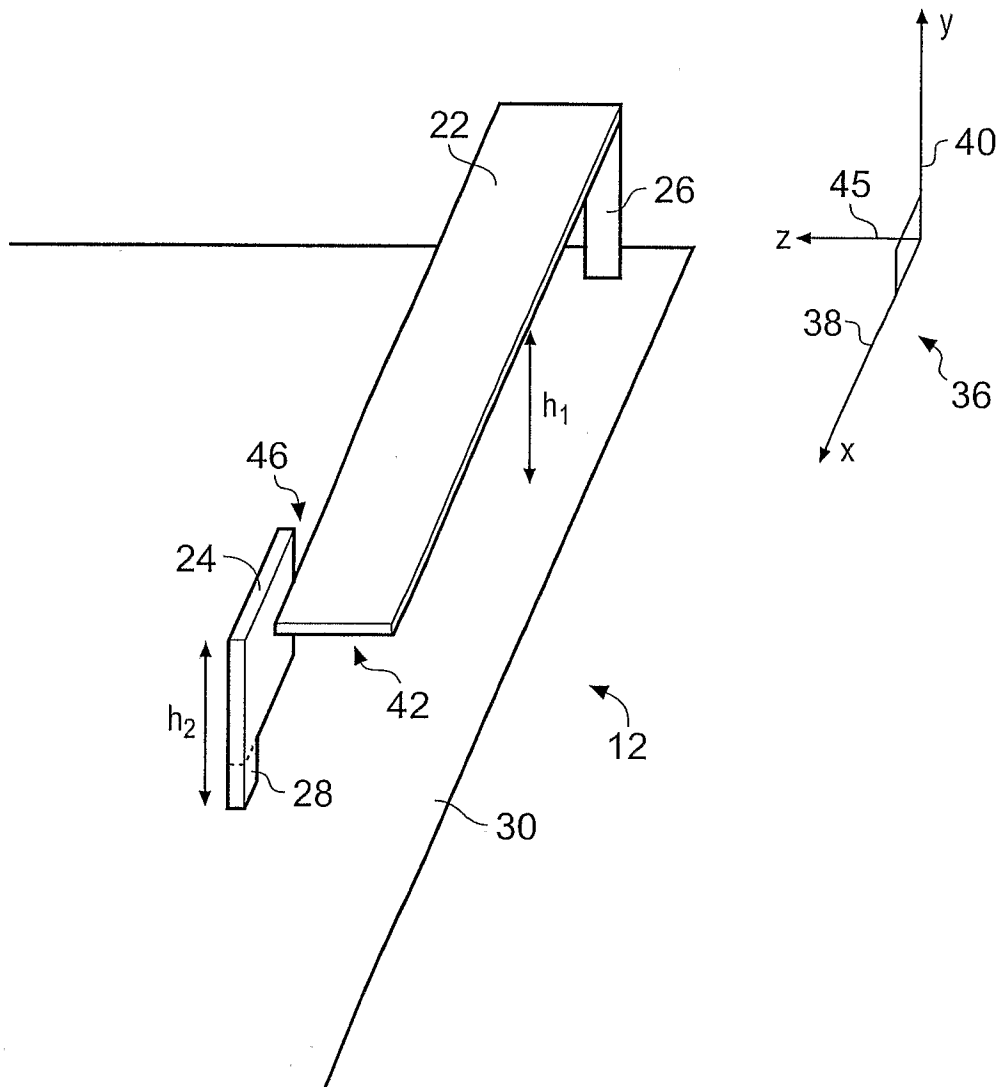

Fig. 4

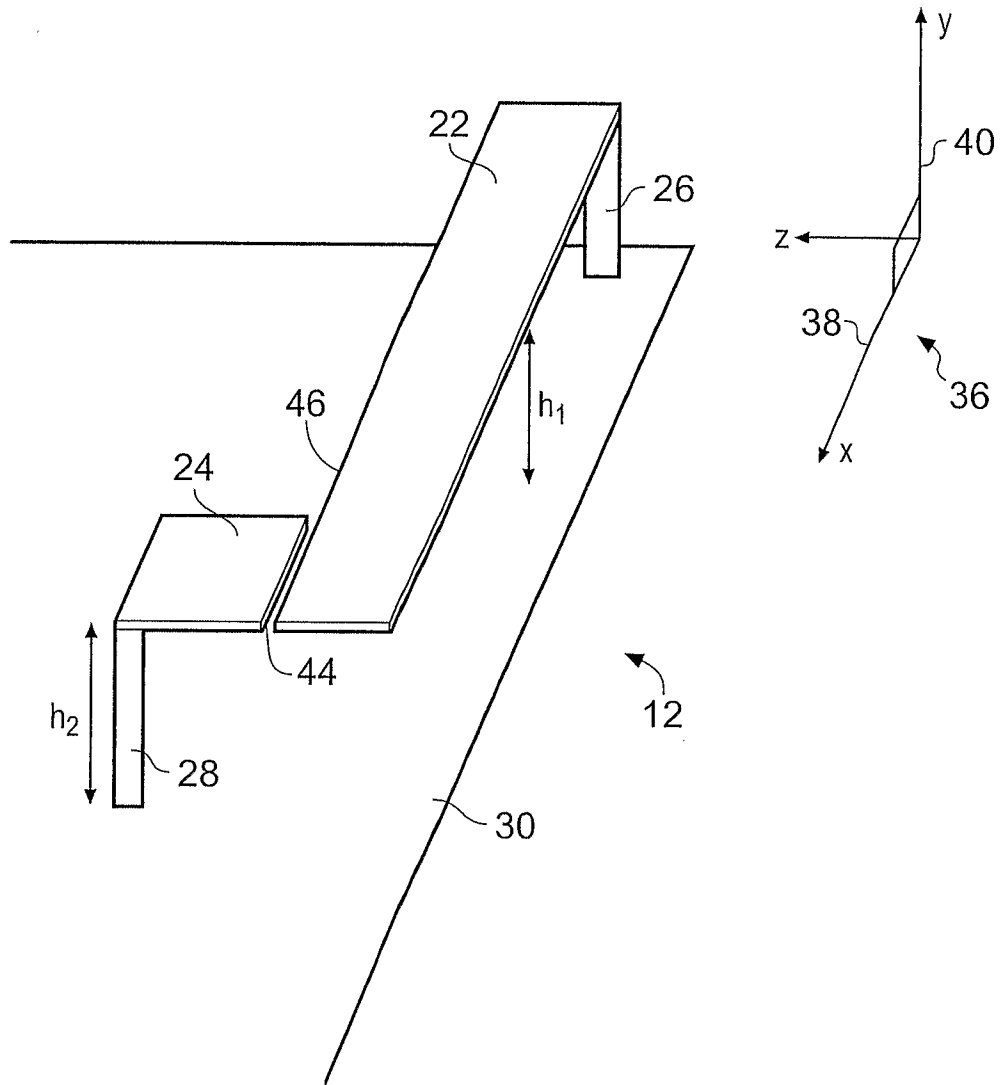

Fig. 5

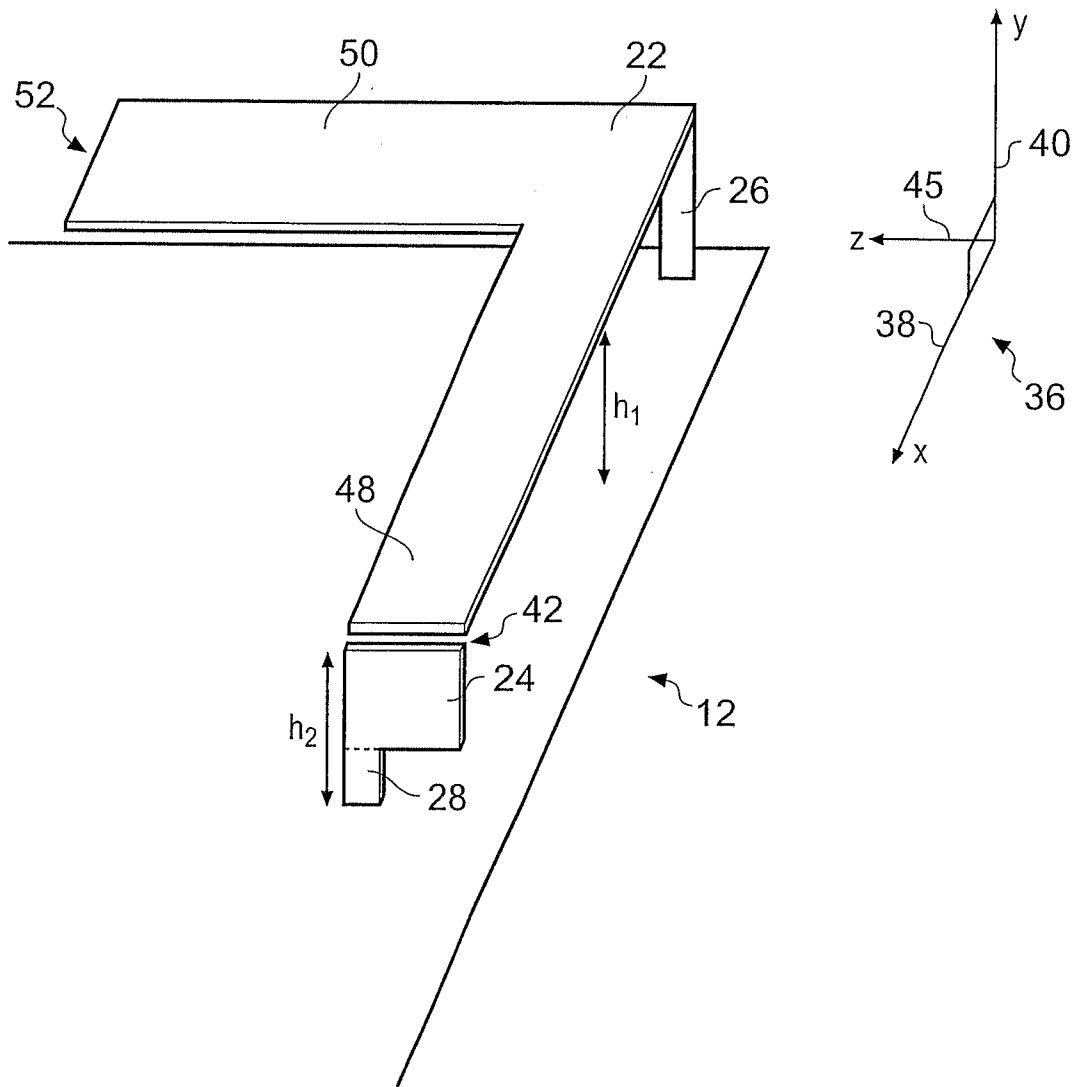

Fig. 6

## INTERNATIONAL SEARCH REPORT

International application No.

PCT/IB2007/001821

## A. CLASSIFICATION OF SUBJECT MATTER

IPC: see extra sheet

According to International Patent Classification (IPC) or to both national classification and IPC

## B. FIELDS SEARCHED

Minimum documentation searched (classification system followed by classification symbols)

IPC: H01Q

Documentation searched other than minimum documentation to the extent that such documents are included in the fields searched

SE,DK,FI,NO classes as above

Electronic data base consulted during the international search (name of data base and, where practicable, search terms used)

EPO-INTERNAL, WPI DATA, PAJ

## C. DOCUMENTS CONSIDERED TO BE RELEVANT

Category*	Citation of document, with indication, where appropriate, of the relevant passages	Relevant to claim No.
A	US 20040227675 A1 (HARANO, N), 18 November 2004 (18.11.2004), paragraph [0007], figure 2 --	1-15
A	WO 02078124 A1 (TELEFONAKTIEBOLAGET LM ERICSSON), 3 October 2002 (03.10.2002), page 2, line 20 - page 3, line 16, figure 1 --	1-15
A	US 20060227052 A1 (TAVASSOLI HOUZOURI, B), 12 October 2006 (12.10.2006), figure 1d, claim 1 --	1-15
A	US 20030112185 A1 (FANG, S-T ET AL), 19 June 2003 (19.06.2003), figure 5, paragraph [0013] --	1-15

 Further documents are listed in the continuation of Box C.
  See patent family annex.

* Special categories of cited documents:	"T" later document published after the international filing date or priority date and not in conflict with the application but cited to understand the principle or theory underlying the invention
"A" document defining the general state of the art which is not considered to be of particular relevance	"X" document of particular relevance: the claimed invention cannot be considered novel or cannot be considered to involve an inventive step when the document is taken alone
"E" earlier application or patent but published on or after the international filing date	"Y" document of particular relevance: the claimed invention cannot be considered to involve an inventive step when the document is combined with one or more other such documents, such combination being obvious to a person skilled in the art
"L" document which may throw doubts on priority claim(s) or which is cited to establish the publication date of another citation or other special reason (as specified)	"&" document member of the same patent family
"O" document referring to an oral disclosure, use, exhibition or other means	
"P" document published prior to the international filing date but later than the priority date claimed	

Date of the actual completion of the international search

17 January 2008

Date of mailing of the international search report

18 -01- 2008

 Name and mailing address of the ISA/  
 Swedish Patent Office  
 Box 5055, S-102 42 STOCKHOLM  
 Facsimile No. +46 8 666 02 86

Authorized officer

 Rune Bengtsson/CC  
 Telephone No. +46 8 782 25 00

## INTERNATIONAL SEARCH REPORT

International application No.

PCT/IB2007/001821

C (Continuation). DOCUMENTS CONSIDERED TO BE RELEVANT

Category*	Citation of document, with indication, where appropriate, of the relevant passages	Relevant to claim No.
A	US 6476769 B1 (LEHTOLA, A), 5 November 2002 (05.11.2002), whole document  -- -----	1-15

**International patent classification (IPC)**  
**H01Q 1/24 (2006.01)**

**Download your patent documents at [www.prv.se](http://www.prv.se)**

The cited patent documents can be downloaded at [www.prv.se](http://www.prv.se) by following the links:

- In English/Searches and advisory services/Cited documents (service in English) or
- e-tjänster/anförda dokument (service in Swedish).

Use the application number as username.

The password is **URRWYDLADQ**.

Paper copies can be ordered at a cost of 50 SEK per copy from PRV InterPat (telephone number 08-782 28 85).

Cited literature, if any, will be enclosed in paper form.

INTERNATIONAL SEARCH REPORT  
Information on patent family members

International application No.  
PCT/IB2007/001821

US	20040227675	A1	18/11/2004	CN	1316678	C	16/05/2007
				CN	1525594	A	01/09/2004
				EP	1453138	A	01/09/2004
				JP	3721168	B	30/11/2005
				JP	2004260434	A	16/09/2004
				US	7026996	B	11/04/2006

---

WO	02078124	A1	03/10/2002	GB	0107239	D	00/00/0000
				GB	2373637	A,B	25/09/2002
				US	6950065	B	27/09/2005
				US	20040233109	A	25/11/2004

---

US	20060227052	A1	12/10/2006	EP	1867005	A	19/12/2007
				US	7242352	B	10/07/2007
				WO	2006110564	A	19/10/2006

---

US	20030112185	A1	19/06/2003	TW	506163	B	00/00/0000
----	-------------	----	------------	----	--------	---	------------

---

US	6476769	B1	05/11/2002	CN	1409437	A	09/04/2003
				CN	100342585	C	10/10/2007
				DE	60200508	D,T	30/06/2005
				EP	1296410	A	26/03/2003
				SE	1296410	T3	
				JP	2003124730	A	25/04/2003

---