

No. 844,687.

PATENTED FEB. 19, 1907.

J. W. MILLER & J. C. HORNING.

DRYING FRAME.

APPLICATION FILED SEPT. 18, 1906.

3 SHEETS—SHEET 1.

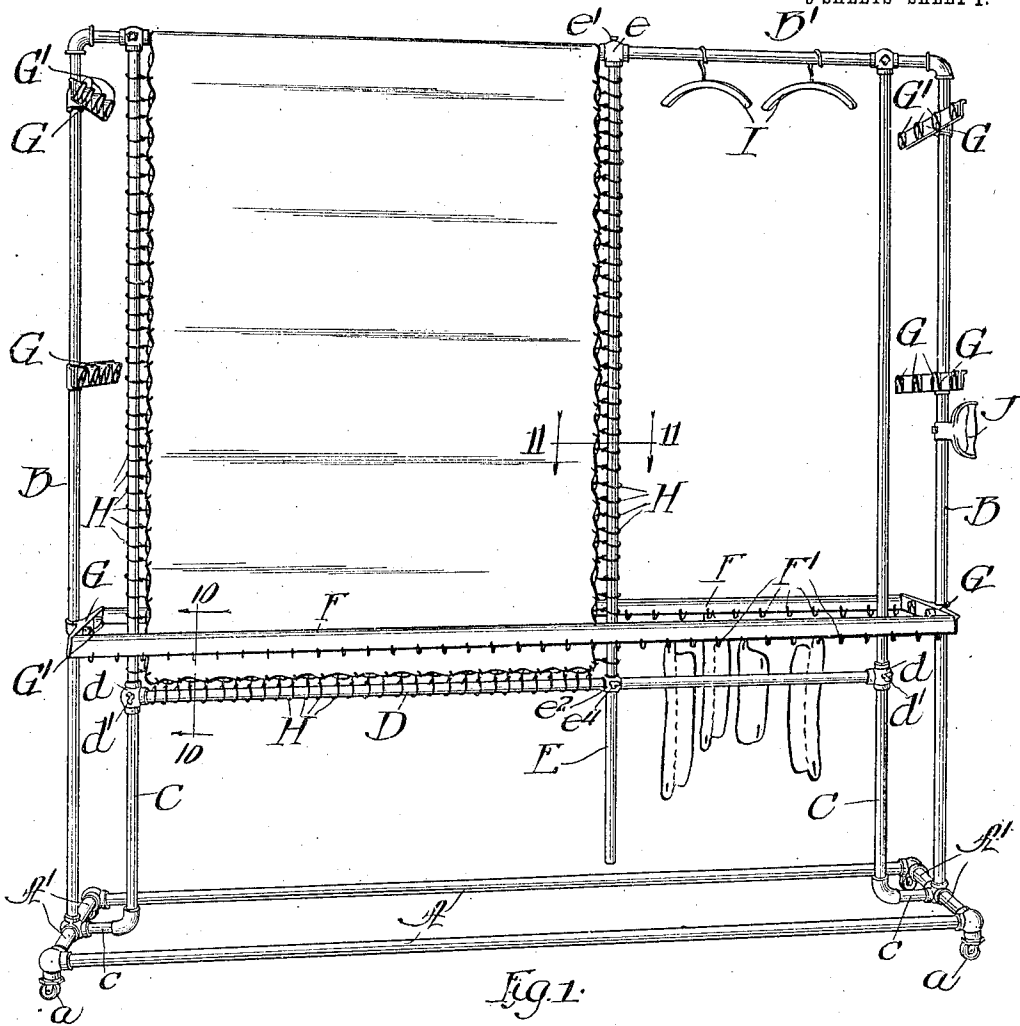

Fig. 1.

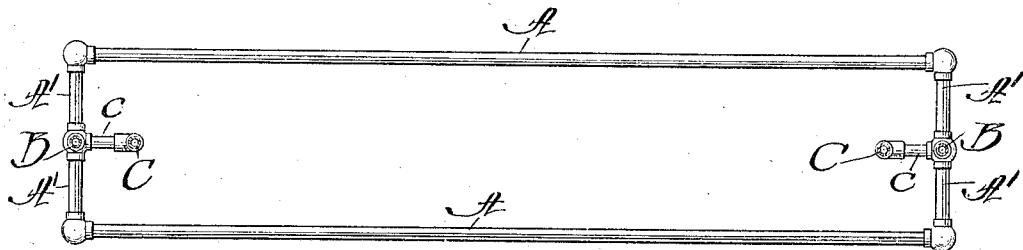

Fig. 2.

Witnesses:
J. H. Alford
W. V. Hall

Inventors:
John W. Miller
Jacob C. Horning
 by *Coak Brown*
 their Attys.

No. 844,687.

PATENTED FEB. 19, 1907.

J. W. MILLER & J. C. HORNING.
DRYING FRAME.

APPLICATION FILED SEPT. 18, 1906.

3 SHEETS—SHEET 2.

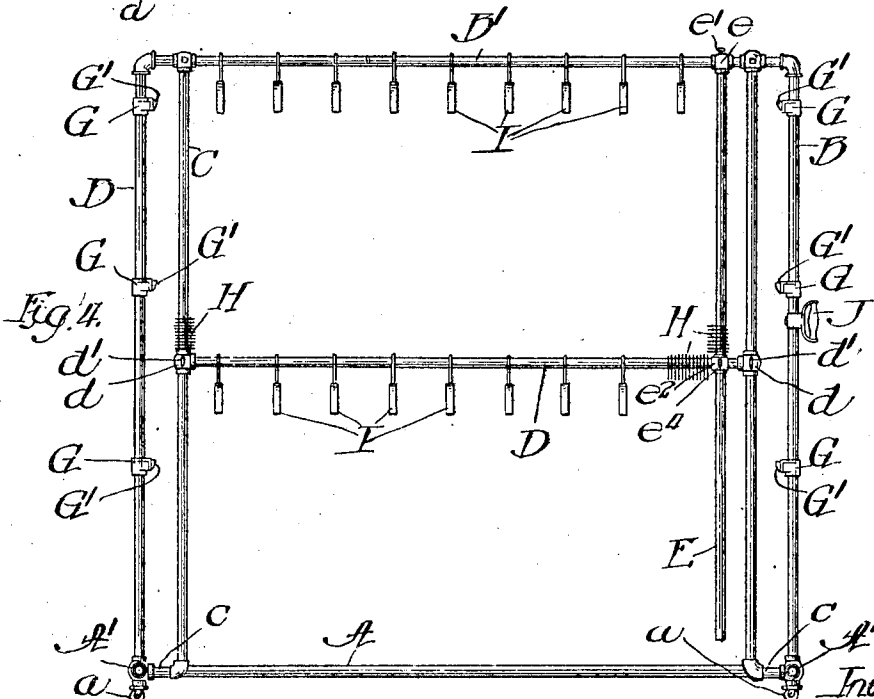
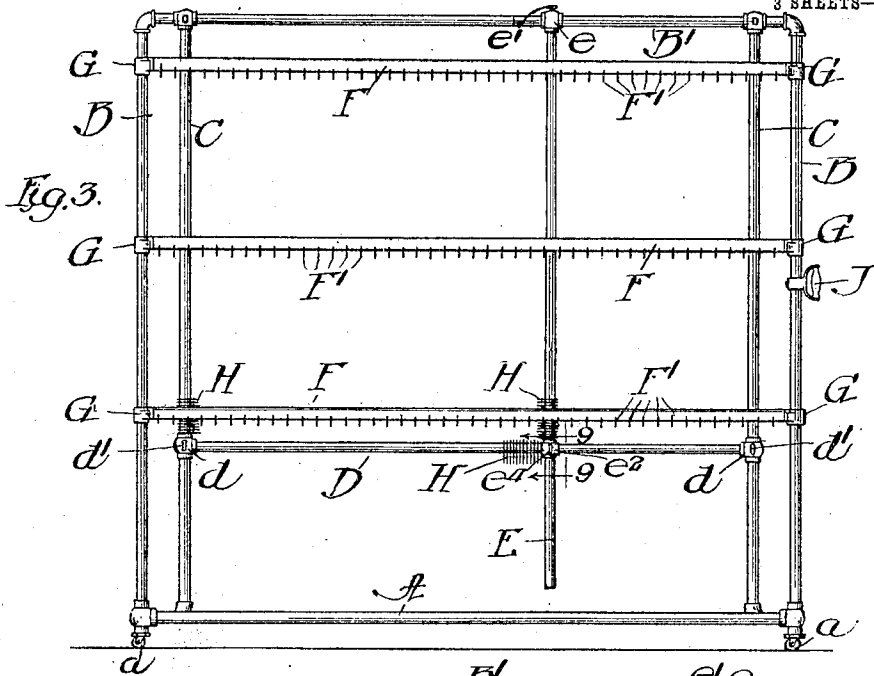

Witnesses:
J. H. Hyde
M. W. Hall

Inventors
John W. Miller
Jacob C. Horning
 by *Coald Brown*
 their Attys.

No. 844,687.

PATENTED FEB. 19, 1907.

J. W. MILLER & J. C. HORNING.

DRYING FRAME.

APPLICATION FILED SEPT. 18, 1906.

3 SHEETS—SHEET 3.

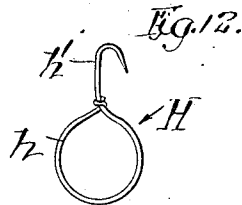
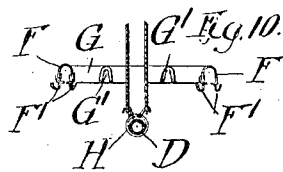
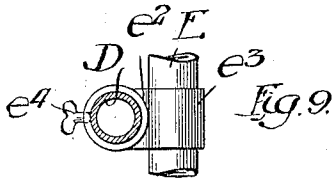
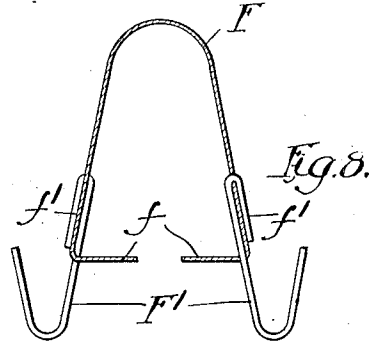
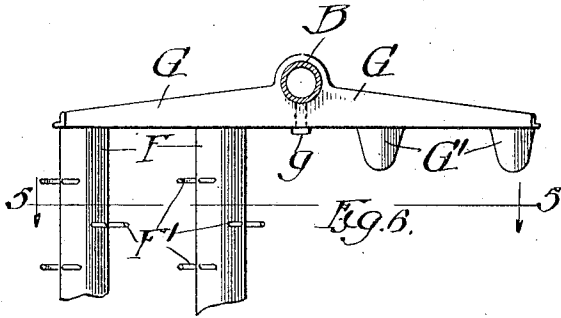
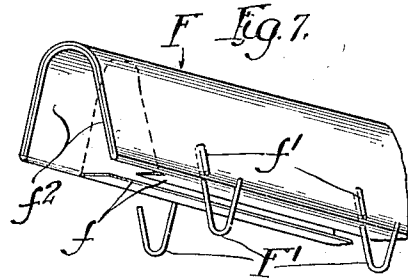
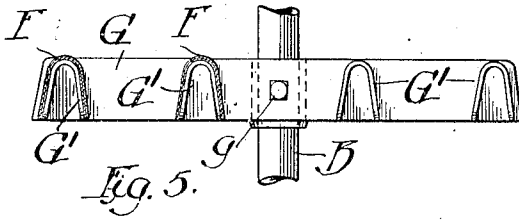

Witnesses:
J. W. Miller
W. Hall

Inventors:
John W. Miller
Jacob C. Horning
 by *Paul Brown*
 their Attys

UNITED STATES PATENT OFFICE.

JOHN W. MILLER AND JACOB C. HORNING, OF CHICAGO, ILLINOIS.

DRYING-FRAME.

No. 844,687.

Specification of Letters Patent.

Patented Feb. 19, 1907.

Application filed September 18, 1906. Serial No. 335,073.

To all whom it may concern:

Be it known that we, JOHN W. MILLER and JACOB C. HORNING, citizens of the United States, of Chicago, in the county of Cook and State of Illinois, have invented certain new and useful Improvements in Drying-Frames; and we do hereby declare that the following is a full, clear, and exact description thereof, reference being had to the accompanying drawings, and to the letters of reference marked thereon, which form a part of this specification.

This invention relates to improvements in drying-frames upon which articles to be dried are suspended or stretched and the frames thereafter moved into a suitable drying-room, in which heated air is passed over the articles to dry the same. The frame when used in this manner may be mounted on a suitable truck, by which the frame is supported and is moved from place to place.

Among the principal objects of our invention is to provide a frame of this character which combines in a single structure a plurality of members, some of which are adjustable and adapted to support in a suspended position for drying shirts, collars, cuffs, and the like, and to also provide a drying and stretching frame for curtains and like articles. The said frame is so constructed that it may be used at its full capacity for drying any one kind of such articles, while being adjustable to provide for drying at the same time a number of or less than all the articles mentioned.

The invention consists in the matters hereinafter set forth, and more particularly pointed out in the appended claims.

As shown in the drawings, Figure 1 is a perspective view of a drying-frame made in accordance with our invention, showing it adjusted for drying at the same time shirts and collars and cuffs and a curtain or the like. Fig. 2 is a horizontal section showing the base or truck members of the device. Fig. 3 is a front elevation illustrating the frame adjusted for drying collars and cuffs. Fig. 4 is a vertical section showing the frame adjusted for drying shirts and like garments. Fig. 5 is a vertical section taken on line 5 5 of Fig. 6. Fig. 6 is a plan view of the parts shown in Fig. 5. Fig. 7 is a fragmentary perspective view of one of the hook-equipped collar and cuff supporting bars. Fig. 8 is a transverse section taken through said bar. Fig. 9 is a

vertical section taken on line 9 9 of Fig. 3. Fig. 10 is a fragmentary section taken on line 10 10 of Fig. 1. Fig. 11 is a horizontal section taken on line 11 11 of Fig. 1. Fig. 12 illustrates one of the hook-rings for fixing a curtain on the stretcher and drying form.

As shown in the drawings, A A and A' A' designate, respectively, the side and end members of a truck frame or base, preferably provided with rollers or casters *a*, whereby the frame may be readily moved from place to place. B B B' designate, respectively, the side members and the top or connecting member of the principal or non-adjusting members of the drying-frame. Said truck members and the frame drying members, as well as the adjustable members of the frame, are preferably made of pipe of suitable weight and diameter joined at their meeting ends by suitable fittings or connections.

C C designate two inner vertical members fixed at their lower ends to the end members of the truck and at their upper ends to the top member of the main frame. They are located a fixed distance inside the side members of the main frame and are connected at their lower ends with the end members of the truck-frame by outwardly-turned portions *c*, as more clearly shown in Figs. 1, 2, and 4.

D designates a horizontal member which is adjustably connected at its end by means permitting vertical adjustment thereof with the inner frame members C C. For this purpose the bars are shown as provided at their ends with apertured fittings *d*, which have sliding engagement with the vertical bar C, and said fittings *d* are fixed in adjustable positions on the bars C by means of set-screws *d'*.

E designates a vertical bar parallel with the bars C C, and it is adjustably connected at its upper end with the horizontal bar B' of the main frame and near its lower end is adjustably connected with the horizontal bar D, whereby said bar E may be adjusted toward and from the inner bars C. The adjustable connection of the bar E with the frame member B' comprises an apertured fitting *e*, that is adjustably connected to the bar B' by means of a set-screw *e'*. The fitting *e* for adjustably connecting the vertical bar E with the horizontal bar D is shown in detail in Fig. 9 and comprises a casting that has a vertical opening through which extends the bar E, and an apertured portion *e*², through which extends the horizontal bar D.

The said fitting e^2 is adjustably connected with the horizontal bar by means of a set-screw e^4 .

F F designate a plurality of horizontal collar and cuff supporting bars which extend between and are supported on the vertical members B B of the main frame. The said bars are shown in detail in Figs. 5 to 8. They are herein shown as made of sheet metal bent to general inverted-U form. Said bars are fitted with hooks F' F' , designed to receive and support collars, cuffs, and the like in suspended position. The said collar and cuff suspending bars constructed as described are supported at their ends on cross-arms G G, adjustably fixed to and extending at right angles to the vertical members B of the main frame. The said cross-bars for the purpose of adjustment are provided with vertical openings through which the bars B extend, and the arms are adjustably fastened to said bars by means of set-screws g . The cross-arms are provided with inwardly-extending short lugs G' , similar in cross-section to that of the bars F, and the ends of the bars are fitted over the said lugs in the manner clearly shown in Figs. 5 and 6. The said bars are thus firmly supported in place, but when desired may be lifted off the lugs to detach the same from the drying-frame.

The lower margins of the inverted-U-shaped bars F are shown as provided with intumed stiffening-flanges ff , made integral with the side walls of the bars. Said flanges are employed for the purpose of strengthening the bar and also for the purpose of facilitating the attachment of the type of hook F' herein shown thereto. The hooks may be made of aluminium or like non-corrosive metal, as herein shown. Their shanks extend upwardly through openings in the marginal flanges f and along the inner faces of the walls of the U-shaped bars and thence extend outwardly through openings in walls and are provided with terminals f' , which are folded downwardly over the outer faces of said walls. This arrangement affords a firm connection of the hooks with the bars, and for that reason is recommended, although other means for connecting the hooks with the bars may be employed.

In order to strengthen the ends of the bars F, which engage the lugs G' of the cross-arms, the sheet-metal blanks from which said bars are made are provided with stiffening-pieces f^2 f^2 , which are folded inwardly and upwardly against the inner faces of the side walls of the U-shaped bars and meet at the tops of said bars, as more clearly shown in Fig. 7. As herein shown, three opposing pairs of cross-arms are employed, and each cross-arm is provided with four supporting lugs G' , located two on each side of the frame member B. A suitable handle J is em-

ployed attached to one of the vertical frame members B, by which the drying-frame is moved on its truck from place to place.

A portion of the upper member B' of the main frame, one of the inner members C, the bar E, and the lower bar D constitutes the curtain stretching and drying frame, the curtain being herein shown as doubled upon itself about the upper frame member B' and adapted to be detachably connected with the side members C and E of the curtain-frame and the bottom member thereof. The detachable fastening devices comprise hooks H, (shown in detail in Fig. 12,) each comprising a ring member h and a hooked member h' . The ring members are adapted to be slipped over the side and bottom bars of the curtain-frame, while the hooks engage the double side and bottom margins of the curtain, as clearly shown in Figs. 1, 10, and 11. The form of curtain stretcher and drier shown is a convenient one for use with the particular construction of frame herein shown, but may be varied to suit other specific forms of the drying-frame. Hangers I may be suspended on the upper frame member B' and on the lower horizontal bar D, (the latter bar being adjustable vertically to proper position,) upon which shirts and like garments may be suspended for drying.

In Fig. 3 the frame is shown as adjusted to form a collar and cuff drying frame, the frame for this purpose being provided with a full equipment of the hook-equipped bars F and cross-arms G. It will be understood that in the arrangement disclosed there are four U-shaped bars for each pair of oppositely-disposed cross-arms, thereby providing twelve of said hook-equipped bars. The vertical members C and E do not in their adjustment interfere with the arrangement of the bars and the articles suspended therefrom, inasmuch as there is sufficient space between the two inner bars F of each set for said members C and E.

As shown in Fig. 4, the drying-frame is arranged for suspending shirts and like garments or articles for drying, the hangers I, upon which said garments are suspended, being arranged upon the upper members B' of the main frame and on the vertically-adjustable horizontal bar D. In this adjustment said bar D is raised to a proper height to afford practically equal spaces below said bars to receive garments of equal lengths.

As shown in Fig. 1, the frame is arranged as a combination-frame to receive a curtain stretched over the curtain-frame to receive at one side of the curtain-frame hangers I, upon which may be supported shirts or like garments, and to receive the collar and cuff suspending bars F. When using the device partially as a curtain stretching and drying frame and partially as a cuff and collar drying frame, preferably but two of said bars F

for each pair of opposing cross-arms are employed in order to afford free access of the drying air to the curtain, although the four bars of each set may be used if the collars and cuffs be suspended from the outermost hooks only of the two inner bars of each set.

It will thus be seen that we have provided an exceedingly simple and economical drying-frame which may with facility be adjusted to receive the various articles mentioned to be dried thereon and which is capable of being adjusted to receive any one of such articles or more than one at the same time. It will also be observed, by reason of the adjustment of the members of the frame described, that we may use the upper portion of the frame for drying shirts and like garments and the lower portion of the frame for suspending collars, cuffs, and the like for drying.

We claim as our invention—

1. A drying-frame embracing means for receiving a stretched curtain thereon to be dried, combined with means for receiving articles in suspended position to be dried, embracing a permanent rigid frame, and horizontal and vertical bars adjustably mounted on the frame, certain of said bars being arranged on the permanent frame to constitute parts of a vertical curtain-frame, and adjustable to occupy more or less of the space in the permanent frame, whereby the device may serve in part as a curtain-drying frame and in part a suspending-frame.

2. A drying-frame embracing means for receiving a stretched curtain thereon to be dried, combined with means for receiving articles in suspended position to be dried, embracing a permanent rigid frame, and horizontal and vertical bars adjustably mounted on the frame, certain of said bars being arranged on the permanent frame to constitute parts of a vertical curtain-frame, and adjustable to occupy more or less of the space in the permanent frame, whereby the device may serve in part as a curtain-drying frame and in part a suspending-frame, and means whereby the bars which constitute part of the curtain-frame may be adjusted out of the position which they occupy when forming part of the curtain-frame, whereby the drying-frame may be used, as a whole, for receiving articles suspended thereon.

3. A drying-frame for the purpose set forth embracing in part, a vertical curtain stretching and drying frame and comprising in part horizontal members located at the side of the curtain-frame, adapted to support in suspended position articles to be dried.

4. A drying-frame for the purpose set forth embracing in part adjustable members designed to form a vertical adjustable curtain stretcher and drier, and in part horizontal, vertically-adjustable bars located laterally at the side of the curtain-frame

adapted to support in suspended position articles to be dried.

5. A drying-frame for the purpose set forth comprising a vertical main frame, bars supported on said frame for receiving articles to be dried thereon in a suspended position, and a vertical adjustable curtain stretching and drying frame supported within the main frame for the purpose set forth.

6. In a drying-frame for the purpose set forth, the combination with the main frame comprising vertical members and a horizontal member connecting the upper ends of the vertical members, of horizontal bars supported on the vertical members for supporting garments in suspended position, and a curtain stretching and drying frame located intermediate said bars for the purpose set forth.

7. In a drying-frame for the purpose set forth, a main frame, two vertical frame members located inside the main frame, a vertical bar adjustable toward and from said inner frame members, and a horizontal bar supported on said inner frame members and vertically adjustable thereon.

8. In a drying-frame for the purpose set forth, a main frame, two vertical frame members located inside the main frame, a vertical bar adjustable toward and from said inner frame members, a horizontal bar supported on said inner frame members and vertically adjustable thereon, and hooks mounted on one of said inner frame members, the said vertical member and said horizontal member, for the purpose set forth.

9. A drying-frame for the purpose set forth comprising a main frame consisting of vertical members and a top member connecting said vertical members, horizontal suspending members mounted on said frame, and a vertical curtain stretching and drying frame supported by the main frame and composed, as a part thereof, of the upper member of the main frame.

10. A drying-frame for the purpose set forth comprising a main frame, consisting of vertical members and a top member connecting the vertical members, two vertical frame members inside said vertical members of the frame fixed at their upper and lower ends to the top and bottom of the frame, respectively, a horizontal bar having vertically-adjustable connections with said frame, a vertical bar having horizontal adjustment on said horizontal bar and the top member of the frame, and hooks on one of said inner vertical members, said vertical bar and the horizontal bar adapted to engage the margins of a curtain folded over the top frame member.

11. A drying-frame for the purpose set forth comprising a base, a main frame comprising vertical members rising therefrom and connected at their tops by a top mem-

ber, two inner frame members connected at their lower ends with the base and at their upper ends with the top member, a horizontal bar supported by and having vertical adjustment on said inner members, a vertical member supported on and having horizontal adjustment on said top member and said adjustable horizontal bar, vertically-adjustable hook-equipped bars supported on said frame at the sides of said horizontally-adjustable vertical member and said inner frame members.

12. A drying-frame for the purpose set forth comprising a base, a main frame comprising vertical members rising therefrom and connected at their tops by a top member, two inner frame members fixed at their lower ends with said base member and at their upper ends with the top member, a horizontal bar supported on and having vertical adjustment on said inner frame members, a vertical bar supported on and having horizontal adjustment on said top member and said adjustable horizontal bar, vertically-adjustable hook-equipped bars supported on said frame at the sides of said horizontally and vertically adjustable bars and said inner frame members, and suspending devices for shirts and like garments adapted to be suspended on said top member and on said vertically-adjustable bar.

13. A drying-frame for the purpose described, consisting of a main frame embracing vertical members and a connecting top member, cross-arms vertically adjustable on said vertical members of the frame and suspending-bars extending between and supported at their ends on said cross-arms.

14. A drying-frame for the purpose described, consisting of a main frame embracing vertical members and a connecting top member, cross-arms vertically adjustable on said vertical members of the frame and hook-equipped bars extending between and supported at their ends on said cross-arms, said bars being made of inverted-U shape in cross-section and the hooks thereof being attached to and depending from the margins of said bars.

15. A drying-frame for the purpose described, consisting of a main frame embracing vertical members and a connecting top member, cross-arms vertically adjustable on said vertical members of the frame, suspending-bars extending between and supported at their ends on said cross-arms, said

bars being made of inverted-U shape in cross-section and hooks attached to and depending from the margins of said bars, the margins of said bars being provided with inwardly-turned flanges and hooks extending upwardly through said flanges and attached to the side members of the bars.

16. A drying-frame for the purpose set forth comprising a main frame comprising vertical members and a top member connecting the same, cross-arms supported on and adjustable vertically of said vertical members of the frame, bars of U shape in cross-section extending between said cross-arms, and lugs extending inwardly from said cross-arms upon which said U-shaped bars are supported.

17. A drying-frame for the purpose set forth comprising a main frame comprising vertical members and a top member connecting the same, cross-arms supported on and adjustable vertically of said vertical members of the frame, bars of U-shape cross-section extending between said cross-arms, lugs extending inwardly from said cross-arms with which said U-shaped bars fit and by which they are supported on said arms, said U-shaped bars being made of sheet metal and the ends thereof which engage said lugs being reinforced for the purpose set forth.

18. In a drying-frame for the purpose set forth, a hook-equipped suspending-bar of U-shape cross-section provided at its lower margins with inwardly-extending stiffening-flanges for the purpose set forth.

19. In a drying-frame for the purpose set forth, a hook-equipped suspending-bar of U-shape cross-section provided at its lower margins with inwardly-extending stiffening-flanges for the purpose set forth, the hooks being provided with shanks which extend through said flanges and thence outwardly through openings in the side wall of said bar and provided with terminal portions which are folded against the outer faces of said side walls.

In testimony that we claim the foregoing as our invention we affix our signatures, in the presence of two witnesses, this 14th day of September, A. D. 1906.

JOHN W. MILLER.
JACOB C. HORNING.

Witnesses:

TAYLOR E. BROWN,
A. M. BURN.