

Feb. 2, 1937.

H. H. RUMPEL ET AL

2,069,331

VIBRATORY SCREEN

Filed Aug. 13, 1934

3 Sheets-Sheet 1

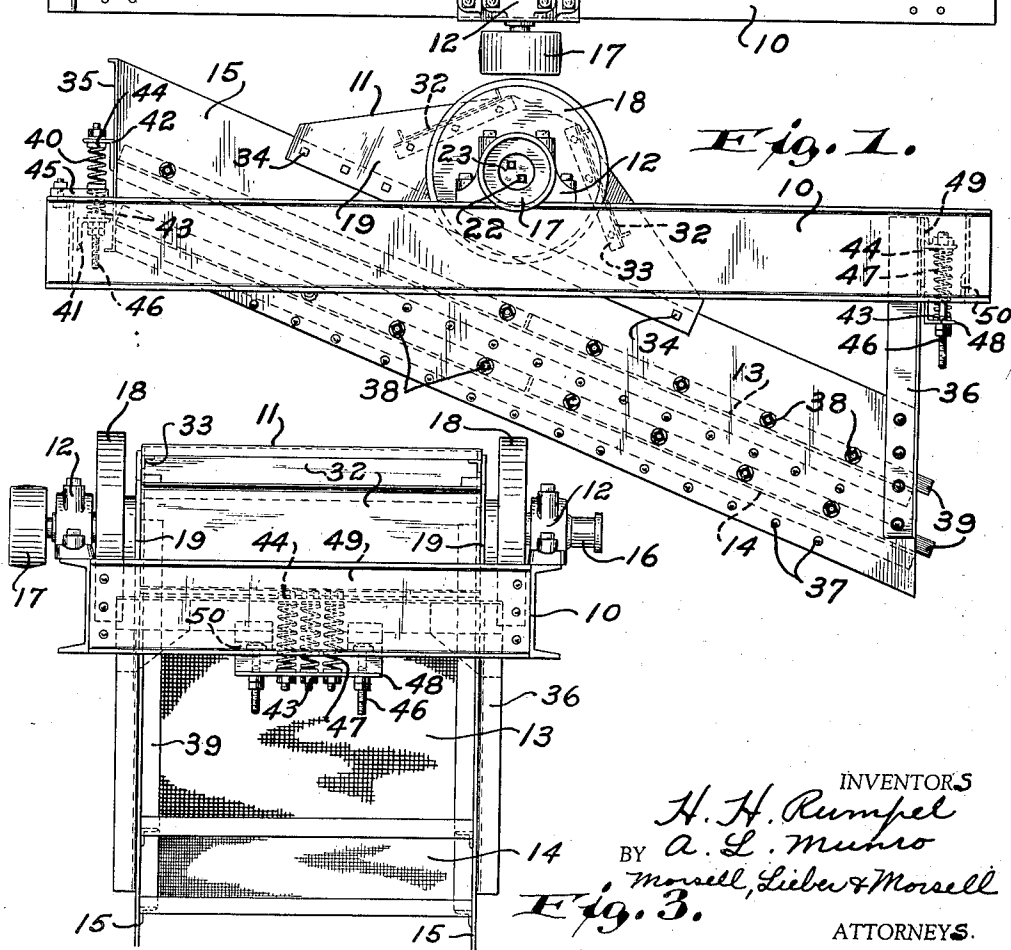
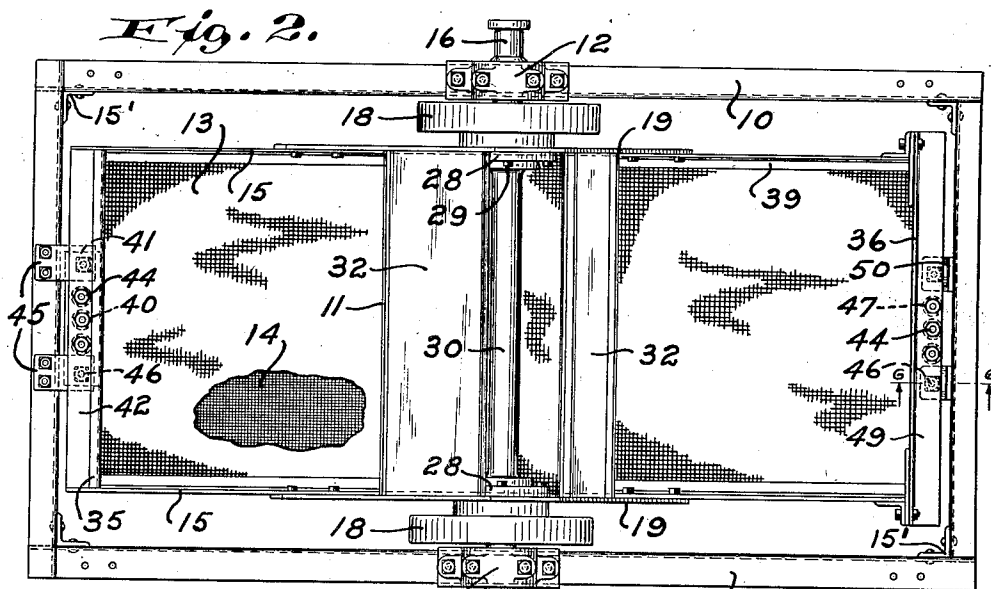

Feb. 2, 1937.

H. H. RUMPEL ET AL

2,069,331

VIBRATORY SCREEN

Filed Aug. 13, 1934

3 Sheets-Sheet 2

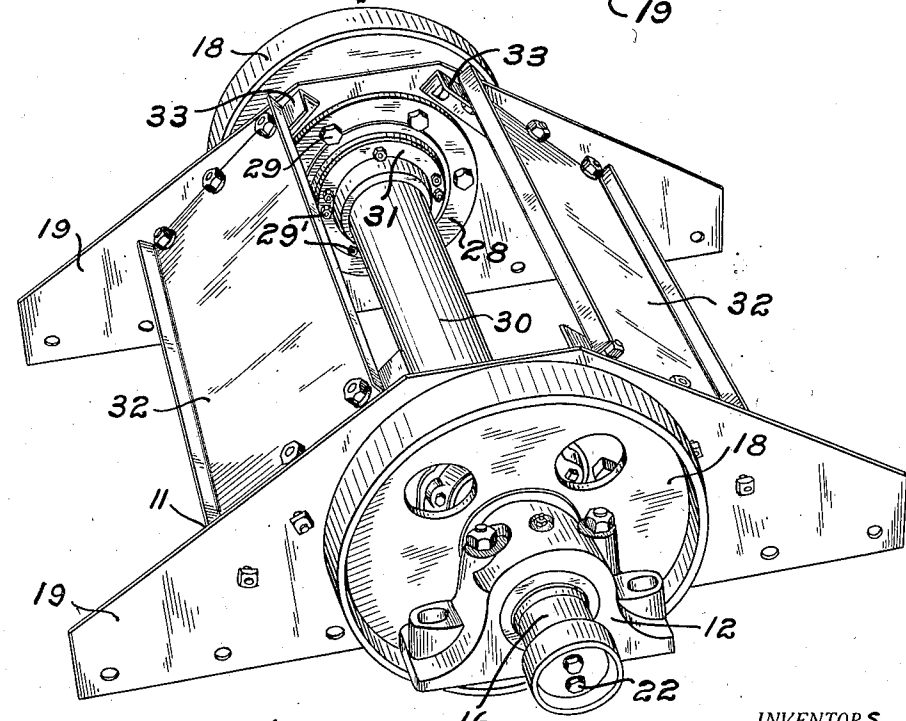
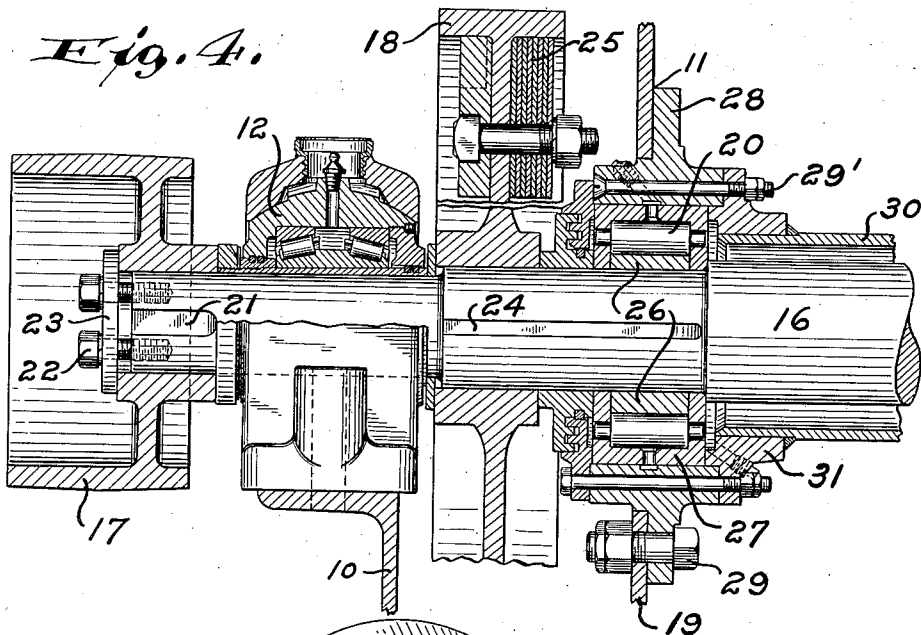

Fig. 5.

INVENTORS
H. H. Rumpel
BY *A. L. Munro*
Morsell, Lieber & Morsell
ATTORNEYS.

Feb. 2, 1937.

H. H. RUMPEL ET AL

2,069,331

VIBRATORY SCREEN

Filed Aug. 13, 1934

3 Sheets-Sheet 3

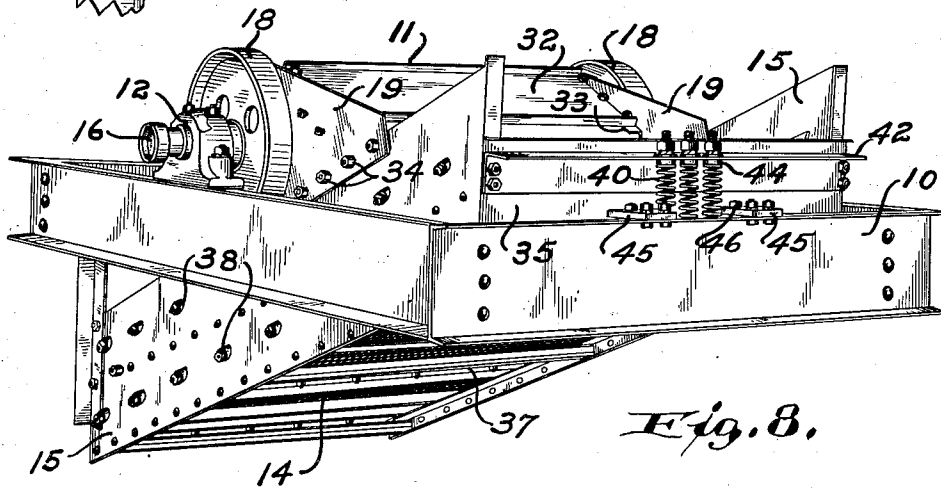
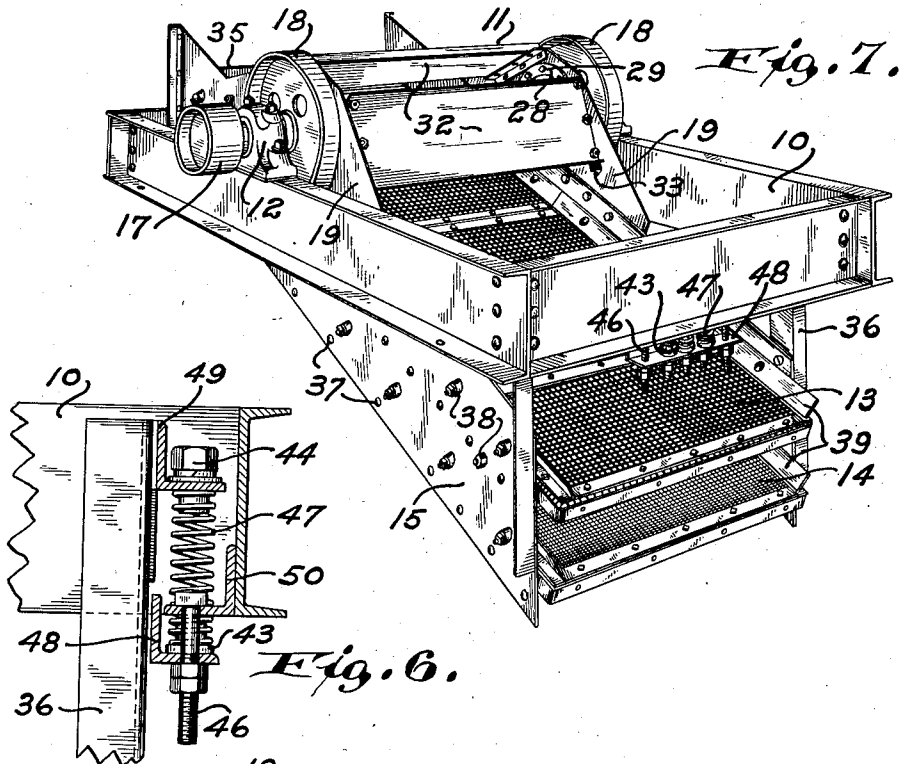

INVENTORS
H. H. Rumpel
BY A. L. Munro
Morsell, Lieber & Morsell
ATTORNEYS.

UNITED STATES PATENT OFFICE

2,069,331

VIBRATORY SCREEN

Harvey H. Rumpel and Alexander L. Munro, Milwaukee, Wis., assignors to Smith Engineering Works, Milwaukee, Wis., a corporation of Wisconsin

Application August 13, 1934, Serial No. 739,516

8 Claims. (Cl. 209—326)

The present invention relates in general to improvements in the art of separating or grading granular materials, and relates more specifically to various improvements in the construction and operation of vibratory screens or the like.

Generally defined, an object of the present invention is to provide a durable and readily adjustable vibratory screen structure, which is highly efficient under various conditions of use.

The matter of constructing a durable and effective vibratory screen, operable at desirably high speed and with minimum destructive effect upon bearings, joints, and supports, especially when the screen is to be operated under variable conditions, presents many perplexing problems which cannot be readily solved. Altho many different forms and types of vibratory screens have heretofore been proposed and are now being marketed, all of these prior devices are deficient in one or more respects, and fail to function efficiently under all conditions of operation to which such apparatus is normally subjected. Most of the prior screening mechanisms fail to provide for uniform and most effective vibration thru-out the entire screening area by failing to incorporate properly located resilient supports for the screening decks. Then too, the prior screen structures do not provide sufficient flexibility in the adjustment of parts, so as to most effectively meet variable operating conditions, while maintaining most efficient vibration regardless of the position of adjustment. The prior screens, moreover, do not sufficiently guard the frames and driving mechanisms against excessive stresses, and are therefore relatively short lived and require frequent, costly repairs; and are, in most cases, so complicated that the frequent and necessary repairs entail extreme time losses. These are only some of the numerous objectionable features which cooperated to make all of the prior vibratory screens more or less objectionable and unable to satisfactorily meet commercial requirements.

It is therefore a more specific object of the present invention to provide an improved vibratory screen which overcomes all of the objections existing in prior structures of this general class.

Another specific object of the invention is to provide an improved resilient support for one or more screening decks, which insures maintenance of uniform and most efficient vibration thru-out the entire screening area.

A further specific object of the present invention is to provide simple and effective mechanism

for varying the number of decks and the angularity of a screen, while retaining substantially equal resilient reaction on all portions of the screening surface.

Still another specific object of the invention is to provide an improved mounting for a vibrating screen, whereby the driving or operating mechanism therefor is substantially relieved from the dead weight of the screening elements.

An additional specific object of the invention is the provision of a durable screen assemblage wherein the frame and driving mechanisms are relieved from undue stresses due to non-uniformity in loading and other causes.

A further specific object of the invention is to provide a screening structure which can be readily and quickly repaired, and wherein the screening units may be conveniently replaced by others in order to vary the capacity and range of grading.

The present invention furthermore contemplates provision of a vibratory screen assemblage which is compact and can be mounted on relatively frail supports without danger of imparting destructive vibration to the supporting structure.

The invention additionally involves the provision of an improved vibrating unit for screens or the like, which is durable in structure, and which may be bodily removed from one screen assembly and applied to another.

The improvement also contemplates the provision of screening mechanism operable at any desired speed and upon materials having a wide range of characteristics, and which may be manufactured and operated at minimum cost.

These and other specific objects and advantages will be apparent from the following detailed description.

A clear conception of an embodiment of the invention, and of the mode of constructing, installing, and of operating vibratory screens built in accordance with the improvement, may be had by referring to the drawings accompanying and forming a part of this specification, in which like reference characters designate the same or similar parts in the various views.

Fig. 1 is a side elevation of a double deck vibratory screen embodying the improvement;

Fig. 2 is a top view of the double deck vibratory screen of Fig. 1;

Fig. 3 is an end view of the screen structure, looking toward the discharge end thereof;

Fig. 4 is an enlarged, fragmentary section taken transversely of the screen assembly thru one set of side bearings of the vibrating unit;

Fig. 5 is a perspective view of one of the vibrating units, removed from the screen assembly;

Fig. 6 is an enlarged, fragmentary section thru the discharge end supporting spring assemblage, the section being taken along the line 6—6 of Fig. 2;

Fig. 7 is a perspective view of the completely assembled screen structure, looking toward the delivery end and driving side; and

Fig. 8 is another perspective view of the assembled screen structure, looking toward the feed end and opposite side.

While the invention has been illustrated and described herein as being specifically applied to a double-deck, inclined, spring-supported screen adapted to be belt driven, it is not intended to limit the scope by such specific disclosure since some of the improved features may also be applicable to other types of screening apparatus.

Referring to the drawings, the improved vibratory screen shown therein comprises in general a rectangular, normally fixed frame or member 10 adapted to be mounted directly upon a suitable support or to be suspended by cables from overhead structure; a vibrating unit 11 mounted in anti-friction side bearings 12 carried by the medial portions of the opposite sides of the frame member 10; and one or more superimposed, inclined screen decks 13, 14 mounted between spaced side plates 15, the upper medial portions of which are rigidly but detachably secured to the unit 11.

The frame member 10 may be formed of heavy channel bar sections rigidly united by means of corner angles 15' riveted and welded in place, and this member is preferably disposed in a substantially horizontal plane, as shown in Figs. 1, 7, and 8. The interior of the frame member 10 is entirely free from obstruction for reception of the screening elements, and the side bars of this frame may be provided with attaching or suspending holes as shown in Fig. 2.

The vibrating unit 11 is illustrated in detail in Figs. 4 and 5, and consists of a rotary horizontal shaft 16 coaxing directly with the side bearings 12 which are carried by the frame member 10, and spanning this member; a driving pulley 17 attachable to either of the projecting ends of the shaft 16; a pair of eccentrically weighted, balancing rotors 18 for the eccentrics secured to the shaft 16 adjacent the bearings 12; spaced side plates 19 suspended from the shaft 16 thru eccentric roller bearings 20; and a plurality of rigid elements connecting the two side plates 19 so as to maintain the same in definitely spaced relationship. The pulley 17 may be either of the cone or grooved type and is detachably connectable to either end of the shaft 16 by means of a key 21 and cap screws 22 coaxing with a clamping plate 23. The rotors 18 attached to the rotating shaft 16 by keys 24, are provided with balancing weights 25 composed of a plurality of laminations, any number of which may be added or removed so as to effect perfect balancing of the eccentrics. The inner eccentric races 26 of the bearings 20 are also attached to the shaft 16 by means of the keys 24, and the outer rings 27 of these bearings are carried by annular brackets 28 which are rigidly connected to the suspension plates 19 by means of bolts 29 as shown in Figs. 4 and 5. The adjacent sides of the brackets 28 are rigidly interconnected by means of a tubular connecting element 30 which surrounds and confines the medial portion of the shaft 16, and the bolts 29' coaxing with ring members 31 attached by welding to the ends of the tubular element 30, also serve to estab-

lish such interconnection. The side plates 19 are additionally rigidly connected at points remote from the shaft 16 and element 30, by means of two relatively inclined, channel-shaped plate elements 32 bolted to angle irons 33 which are firmly attached to the inner sides of the plates 19, thereby providing a rigid screen supporting cradle which is suspended from the rotary shaft 16 thru the eccentric roller bearings 20.

The screen deck mounting plates 15 are adapted to be attached at their medial upper portions directly to the lower elongated ends of the cradle plates 19, by means of a series of removable bolts 34 as illustrated in Fig. 1. These mounting side plates are spaced apart and rigidly interconnected by means of an upper flat beam 35 at the feed end, a U-shaped beam 36 at the discharge end, and a series of parallel, transverse spacer bars 37 located intermediate said ends and beneath the screen decks 13, 14. The upper and lower screen decks 13, 14 are firmly but removably attached to the side plates 15 by means of bolts 38 coaxing with clamping strips 39, and these decks may be disposed either parallel or at a slight angle to each other. The use of the U-shaped spacing beam 36 at the delivery end of the screen provides clearance for unobstructed discharge of the separated materials.

The resilient mountings for the opposite ends of the screen deck support are associated with the medial portions of the spacer beams 35, 36 respectively and with the adjacent medial portions of the transverse end beams of the supporting frame member 10. The feed end resilient mounting comprises one or more laterally deflectable coil springs 40, the lower ends of which rest upon a vertically adjustable, horizontally disposed angle plate 41, and the upper ends of which react against a horizontally disposed angle plate 42 rigidly attached to and substantially forming a part of the upper flat spacer beam 35. The lower and upper ends of the springs 40 are fitted over confining lugs 43, 44 secured to the angle plates 41, 42 respectively; and the lower plate 41 is vertically adjustably connected to spaced, flat plates 45 rigidly attached to the frame member 10, by means of adjusting bolts 46. The discharge end resilient mounting comprises one or more laterally deflectable coil springs 47, the lower ends of which rest upon a vertically adjustable, horizontally disposed angle plate 48, and the upper ends of which react against a horizontally disposed angle plate 49 forming the upper, medial portion of the U-shaped spacer beam 36. The lower and upper ends of the springs 47 are again fitted over confining lugs 43, 44 secured to the angle plates 48, 49 respectively; and the lower plate 48 is vertically adjustably connected to laterally spaced angular plates 50 rigidly attached to the frame member 10, by means of adjusting bolts 46. It is to be noted that these spring mountings for the screen ends are confined to the central, longitudinal plane of the screen assemblage; and that by properly adjusting the bolts 46, the springs 40, 47 may be caused to carry the dead weight of the vibratory screen structure, thereby entirely relieving the bearings 12, 20 of this weight. It is also to be observed that both the eccentric bearings 20 and the main bearings 12 are of the anti-friction type and are effectively guarded and packed against the entry of dust and other foreign matter.

During normal operation of the improved screening mechanism, the frame member 10 is properly supported in substantially horizontal

position, as shown in Fig. 1, and the shaft 16 of the vibrating unit is being rotated at high speed by power applied to the pulley 17. The rotating shaft 16 carries with it the eccentric bearing

5 races 26 and their balancing rotors 18, and the eccentrics 26 impart rapid vibratory motion to the screen decks 13, 14 thru the suspension plates 19 and side plates 15, while the rotors 18 prevent transmission of the vibrations to the frame 10. 10 The material to be screened is delivered to the upper surface of the upper deck 13 over the end beam 35, and travels downwardly over this upper deck. During its advancement over the upper deck 13, all particles of material which are capable of passing thru this deck are deposited upon the upper surface of the lower deck 14, and the oversize material from the upper deck 13 is eventually discharged at the lower end thereof and is precipitated into a suitable receiving compartment. The material passing along the lower deck 14 is separated into the fines, which pass thru this deck, and the intermediate size material, which is eventually discharged from the lower end of the deck 14 into another suitable receiving compartment. 25

By proper adjustment of the bolts 46, the end springs 40, 47 may readily be caused to substantially relieve the bearings 12, 20 of the dead load or weight of the vibratory parts, and of some of the weight of the material. When the material is deposited upon the screen decks, some of the weight thereof may be borne by the bearings 12, 20, but these bearings may, by proper adjustment of the springs 40, 47, be practically relieved of pressure other than that introduced by the driving belt, when the screen is unloaded. 30

The disposition of the resilient supports comprising the springs 40, 47, near the central, longitudinal plane of the screen structure, causes uniform distribution of the pressures upon these supports. By proper adjustment of the bolts 46, it is also possible to vary the inclination of the screen decks, thereby varying the rapidity with which the material travels along these decks. 35 The horizontal disposition of the frame member 10 permits convenient mounting of the screen structure upon any kind of a foundation, and the rate of travel of the material along the screen decks may also be varied by slightly, longitudinally tilting the supporting frame 10. The location of the vibrating bearings 20 and the counterbalancing rotors 18 therefor, on opposite sides of the plane of support of the screen decks, also results in the impartation of minimum vibration to the frame member 10. 40 45

The vibrating unit 11 may be conveniently removed from the screen deck assembly by releasing the bolts 34, and a substitute deck assembly having either a greater or lesser number of decks or decks of different mesh, may then be substituted for the removed assemblage. This change can be made quickly and with minimum inconvenience. The cradle of the unit 11 is of extremely rigid construction by virtue of the provision of the connecting tubular element 30 surrounding the shaft 16, and the additional provision of the U-shaped bracing plates 32 disposed remote from the tubular element 30. The extreme width of the side plates 19 of the unit 11 also insures maximum rigidity in the entire structure and prevents possible weaving of the screen deck supporting frames consisting of the side plates 15 and the end beams 35, 36. The balancing rotors 18, disposed closely adjacent to the screen vibrating eccentrics 26, prevent unde-

sirable transmission of vibrations to the main supports and thereby protect the foundations.

From the foregoing disclosure, it will be apparent that the present invention provides an extremely simple and highly efficient vibratory screen structure which is relatively flexible in use and adaptation. The assemblage is readily adjustable so as to permit operation with minimum power consumption and with minimum destructive vibration and can be conveniently mounted upon any desired type of supports. The improved vibratory screen has proven highly successful in actual commercial operation and is extremely durable in construction. 10 15

It should be understood that it is not desired to limit the invention to the exact details of construction and to the precise mode of operation herein shown and described, for various modifications within the scope of the claims may occur to persons skilled in the art. 20

It is claimed and desired to secure by Letters Patent:

1. A vibratory screen, comprising, a normally fixed substantially horizontal frame support, an inclined screen member extending downwardly through said support, vibrating means carried by said support on opposite sides of said member and coacting with the latter between its upper and lower ends, and vertically adjustable spring means coacting with said member and with said support only at the medial portions of the ends of said member. 25 30

2. A vibratory screen, comprising, a stationary supporting frame, an angularly adjustable inclined screen deck located near said frame, vibrating means carried by said frame and extending across and coacting with said deck intermediate its upper and lower ends, vertically adjustable spring means coacting with said deck and with said frame only near the central longitudinal plane of said deck, and means for adjusting said spring means so as to relieve said vibrating means from the dead weight of said deck. 35 40

3. In a vibratory screen, a normally fixed frame having spaced side beams interconnected by end beams, a shaft mounted in bearings carried by said side beams, an inclined screen deck suspended from said shaft and extending downwardly through said frame between said side and end beams, and vertically adjustable resilient supports coacting with the medial portions only of said end beams and of the ends of said deck. 45 50

4. In a vibratory screen, a rotary shaft, spaced eccentrics carried by said shaft, side plates suspended from said shaft thru said eccentrics, a tubular element surrounding said shaft and rigidly connecting said side plates near said shaft, plate elements rigidly interconnecting said side plates remote from said tubular element to form a cradle, and a screen deck having permanent side supports detachably suspended from said cradle plates. 55 60

5. In a vibratory screen, a rotary horizontal shaft, spaced eccentrics carried by the medial portion of said shaft, vertical side plates suspended from said shaft thru anti-friction bearings coacting with said eccentrics, a tubular element rigidly interconnecting said plates near said eccentrics, U-shaped plate elements rigidly interconnecting said plates remote from said eccentrics to form a cradle, and an inclined screen deck having permanent side supports detachably suspended from said cradle side plates. 65 70

6. In a vibratory screen, a rotary shaft, ec- 75

centric means carried by said shaft, spaced side plates suspended from said shaft thru said eccentric means, an element rigidly interconnecting said plates near said eccentric means, other
5 elements rigidly interconnecting said plates remote from said eccentric means to form a cradle, a screen deck having permanent side supports detachably suspended from said cradle plates, and means coacting with said deck for relieving
10 said eccentric means from the dead weight of said deck and of said plates and the interconnecting elements.

7. A vibratory screen, a rotary shaft, bearings for said shaft, eccentric means carried by
15 said shaft, a cradle suspended from said shaft thru said eccentric means, a screen deck sus-

pendent from said cradle, and vertically adjustable resilient means coacting with the opposite medial end portions of said deck for relieving said bearings and said eccentric means from the
5 dead weight of said cradle and of said deck.

8. In a vibratory screen, a rotary shaft, eccentric means carried by said shaft, a cradle coacting with said eccentric means, a screen deck suspended from said cradle, laterally deflectable
10 vertically disposed coiled springs coacting with the opposite medial portions of the ends of said deck, and means for effecting bodily vertical adjustment of said springs.

HARVEY H. RUMPEL.
ALEXANDER L. MUNRO.