

Marrin & Seely,

Steam-Boiler Water-Tube.

N^o 1746.

Patented Aug. 28, 1840.

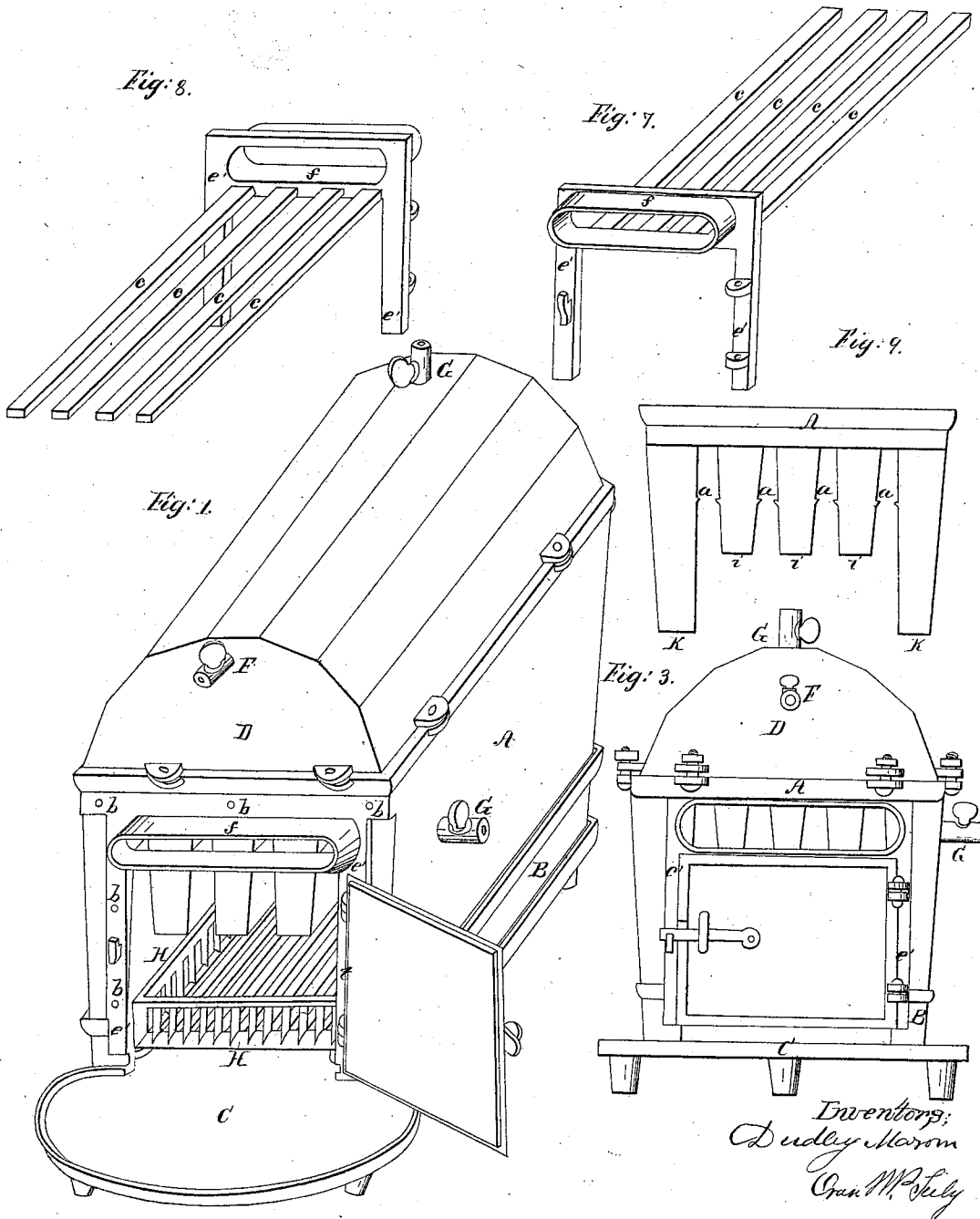

Inventors:
Dudley Marrin
Gerrit M. Seely

Marrin & Seely,

Steam-Boiler Water Tube.

N^o 1746.

Patented Aug. 28, 1840.

Fig: 5.

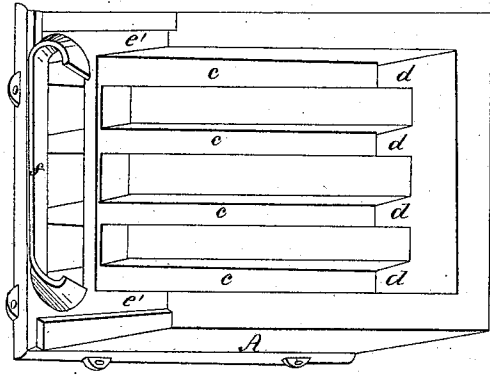

Fig: 4.

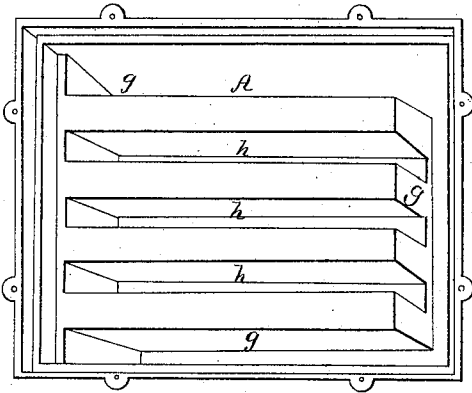

Fig: 6.

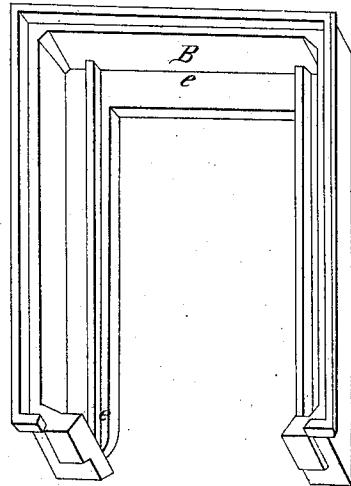
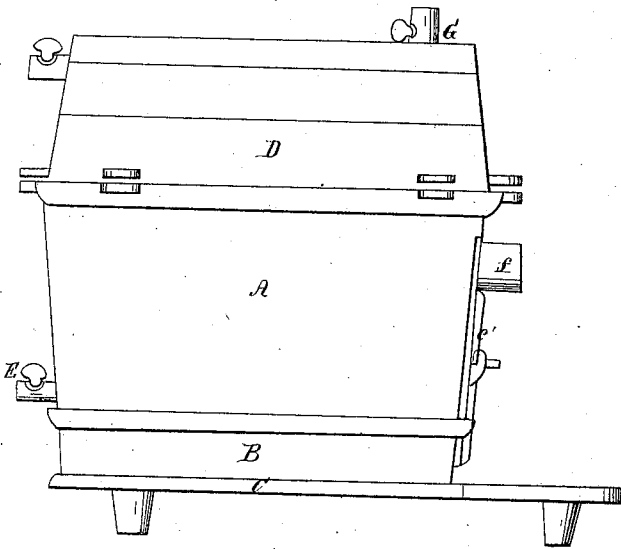

Fig: 2.



Inventors:
 Dudley Marrin
 Grant W. Seely

UNITED STATES PATENT OFFICE.

DUDLEY MARVIN; OF NEW YORK, AND ORAN W. SEELY, OF SODUS,
NEW YORK.

IMPROVEMENT IN STEAM-BOILERS AND EVAPORATORS.

Specification forming part of Letters Patent No. 1,746, dated August 28, 1840.

To all whom it may concern:

Be it known that we, DUDLEY MARVIN, of the city of New York, in the State of New York, and ORAN W. SEELY, of the town of Sodus, in the county of Wayne, in said State, have invented a new and Improved Boiler or Evaporator for Cooking and Performing other Operations by Steam; and we do hereby declare that the following is a full and exact description of the construction and operation of the same, reference being had to the annexed drawings, making a part of this specification.

The nature of our invention consists in the particular manner in which we construct a boiler for generating steam for the purpose of cooking or of steaming articles of various kinds, by which construction a large heating-surface is presented to the action of the fire and by which fuel is greatly economized, and also in so forming the principal part of said boiler as to admit of its being readily molded without the use of dry cores and cast in one entire piece. Said improvement is designed to place within the convenient use of farmers the advantages of submitting articles of food for their cattle, swine, &c., to the action of heat or the cooking process through the intermedium of steam. It is also applicable to various mechanical and manufacturing purposes, such as dyeing, bleaching, and distilling, as likewise for culinary purposes generally.

In constructing our boiler or evaporator the principal casting or main body of the stove, which constitutes the receptacle for water, is so constructed as that its sides and ends shall contain water, and that by means of certain depressions, which we denominate "water-cells," the heated air from the fuel may be carried back and forth or reverberated through flues of a peculiar construction. This water-receptacle is usually placed upon another casting, which we denominate a "pedestal," within which is contained the fire-grate for the reception of fuel. This pedestal rests on a stool or bottom plate furnished with legs, and being similar in all respects to the ordinary bottom plate of stoves. We generally cast the grate in one piece and make it to draw in and out; but this does not constitute an essential part of the structure, as wood or any other fuel may be employed and the

fire-chamber be adapted thereto. Above the principal casting or water-receptacle is a cap or cover, which incloses the top of the boiler and forms a steam-chamber, from which the steam that is generated is to be conducted through suitable cocks or openings, wherever may be required. This cap or cover may be made of cast-iron or sheet metal.

To enable the mechanic and all for whose use our improvement is intended to construct or cause the same to be constructed, we will now describe the same, and the better to do so we have annexed several perspective and sectional drawings, in which—

Figure 1 is a perspective view of the whole of the boiler. Fig. 2 is a longitudinal side view thereof. Fig. 3 is a front elevation. These last two figures show the tapering form of the principal casting, which is made smaller at the bottom than at top, thus having an easy draft from the top of it on the inside, as it has also on all the sides of the water-cells, and the sides of the cavities for the passage of heat, thus enabling the molder to form the mold for the casting with but one pair of flasks and without cores. Fig. 4 is a top perspective view showing the arrangement and construction of the water-cells of the principal casting, the cap or cover being removed in order to exhibit these parts distinctly. Fig. 5 is a perspective view of the bottom and front end of the same, but having the bottom plate and pedestal removed and a portion of the flange of the smoke-flue left out, showing the internal arrangement of the lower part or bottom of the water-cells and of the division-piece, which will be hereinafter described and its use explained. Fig. 6 is a perspective view of the pedestal-piece next above the stool or bottom plate, upon which the principal casting is placed, and forms, with the grate, the lower part of the furnace of the boiler.

Fig. 7 is a front perspective view of what we denominate the "division-piece," forming the reverberating flues of the boiler or principal casting. The bars *ccc* of this piece are made to slide into their places in the principal casting and rest on bearers or projecting knobs between the water-cells. (Shown at *aaa*, Fig. 9.) This division-piece may be secured to the principal casting by rivets, as

shown at *b b b*, Fig. 1. To the front *e' e' e'* of this piece the door of the furnace is hung, and the bars *c c c c*, Figs. 5, 7, and 8, dividing the spaces between the water-cells horizontally and extending from the front nearly to the back end of these spaces, form flues and carry back the draft of heat to the back part of the furnace, and by the openings or flues at *d d d d* return it forward to the smoke-flue situated in front of the boiler. This division, by which a return-flue for the volume of heat is secured, prevents a suspension of the draft when the door of the furnace is open and produces a more perfect combustion of the fuel and a more complete expenditure of the heat in generating steam.

Fig. 8 is a back perspective view of the division-piece, and Fig. 9 is a sectional front view of the principal casting, showing the bearings or projections *a a a* for the support of the division-piece when the parts are put together, and also distinctly showing the taper of the water-cells and the divisions between them, so as to cause the whole to draw freely from the mold in the operation of casting.

The parts thus shown, when taken collectively and properly combined, as shown at Fig. 1, constitute a boiler of seven pieces of casting, viz: first, the stool; secondly, the pedestal-piece; thirdly, the principal casting; fourthly, the cap or steam-chamber, being a succession of four main pieces from the bottom to the top with the additions of, fifthly, the division-piece; sixthly, the grate, and, seventhly, the door-piece. This number of pieces, however, may be varied and the parts may undergo some change without essentially altering the nature of our invention.

A A A A A, Figs. 1, 2, 3, 4, 5, and 9, is the principal casting formed with parallel water-cells, as seen at Fig. 4, and having four parallel spaces between them for the passage of the heat, as seen at Fig. 5. The cells *g g g*, surrounding those of the center *h h h*, extend around the two sides and the back part of the boiler and also down to the bottom of the principal casting, and thus give to three sides of the furnace a bank of protection and an extended surface exposed to heat. The three center cells *h h h* are less deep, giving the capacity or space necessary to the furnace over which they are located. These make together five parallel receptacles for water or water-cells, which are connected or combined by means of the cross-cell at the back part, thus admitting a free circulation of the water from one part of the boiler to the other and forming between the five parallel cells by the aid of the division-bars *c c c* four parallel flues for the passage of the flame and circulation of the heat acting upon the sides thereof.

In Fig. 9, *i i i* are the bottoms of the middle, and *k k* of the outer, water-cells, which latter rest upon the pedestal.

B B B B, Figs. 1, 2, 3, and 6, is the pedestal, upon which the principal casting is placed, resting upon the stool *C* and making at *e e*,

Fig. 6, a seat for the grate and below an ash-pan.

C C C, Figs. 1, 2, and 3, is a stool or ordinary bottom plate with legs.

D D D, Figs. 1, 2, and 3, is a cap forming the steam-chamber. The same may be fastened by screw-bolts, as shown at Fig. 3, and may be constructed of cast or of sheet metal.

E, Fig. 2, is a valve or cock in the boiler of the principal casting for the introduction of the supply of water, which may be taken from any tub or cistern standing alongside of or at any convenient distance from the boiler, it being connected therewith by means of a pipe. By placing a supply-tub at a proper height and leaving it open at top the height of the water may be readily determined, as its level will be the same in the supply-tub and in the boiler.

F F, Figs. 1 and 3, is a valve or cock which may open into the smoke-pipe when it is desired to let off the steam in that way.

G G G G, Figs. 1, 2, and 3, are valves or cocks from which the steam may be conducted to the object required to be acted upon. There may be several such inserted into the cap to suit the convenience of the operator—as, for instance, if for cooking potatoes or other vegetables for the food of cattle or for analogous operations, we connect a valve by a pipe to the bottom of a tub containing the vegetable, passing the same through the bottom and covering the top thereof. The steam is then let on and the process perfected, and in like manner and from any part of the cap the steam may be conducted to any distilling, bleaching, dyeing, or refining apparatus for heating rooms in dwellings and factories and for various culinary and mechanical purposes.

H H, Fig. 1, is a grate under the boiler, which may be made to slide out on suitable ways, and will be found the most convenient mode of construction when coal is used as fuel.

Operation: When put into operation, the volume of heated air is drawn to the back part of the furnace, passes up at the back ends of the plates of the division-piece, and thence toward the front. The openings marked *d d d d*, Fig. 5, constitute the passage into the reverberating flues at the ends of the division-piece. The draft is returned forward to openings inclosed within the flange *f*, Figs. 1, 5, 7, and 8, and escapes up the smoke-flue.

It may be observed that no further precaution is necessary in the use of this boiler than to note that some one of the valves be always open, so that there may be an escape for steam—that is, when all the valves are thrown out of use and closed upon objects acted upon the valve connected with the smoke-pipe should be opened—and also to note that the water in the supply-tub be kept up, so as to secure the immersion of all the surfaces of the boiler which are exposed to the direct heat of the furnace.

For manufacturing and mechanical purposes with power conveniently at hand a force-

pump may be added to contribute to the supply of water, or a jet or conductor from a flume or other reservoir of water may be taken in quantity more than a supply and graduate the level desired by a waste-weir; but for all temporary purposes the supply-tub sufficiently filled at the commencement of its use is all that is necessary.

Having thus fully described the nature of our invention and the manner in which we carry the same into operation, what we claim therein, and desire to secure by Letters Patent, is—

1. The manner in which we have constructed and combined the respective parts of our boiler or steam-generator with each other, as above described—that is to say, the formation of the water-cells, consisting of one which surrounds the three sides of what we have denominated the “principal casting,” extending down to the lower edge of said casting and having three or any preferred number of water-cells intermediate between the cells at the sides of the principal casting, said intermediate cells extending down so far as to leave the requisite space for the fire-chamber, and having spaces between them which are to be converted into reverberating flues by means of partition or division pieces, lo-

cated and operating in the manner herein set forth.

2. The forming or making of that part which we have denominated the “principal casting” in one single piece of cast-iron by giving to the respective parts thereof the designated taper and otherwise constructing the pattern in the way described, so that it will draw from the mold and may be cast in a single pair of flasks without the employment of cores.

It is to be distinctly understood that, although we have given specific directions for forming the respective parts of our boiler, we do not intend to limit ourselves to the precise form and number of parts, but to vary these as we may think proper, while we attain the same end by means substantially the same. It may be found convenient, for example, to cast the bars of the division-piece separate from each other instead of connecting them to a front piece to which the door is hinged. This we give as an example of changes that would not alter the real construction or mode of action.

DUDLEY MARVIN.
ORAN W. SEELY.

Witnesses:

B. K. MORSELL,
W. THOMPSON.