

W. M. PIATT.
EJECTOR ATTACHMENT FOR HARVESTERS.

APPLICATION FILED AUG. 13, 1902.

NO MODEL.

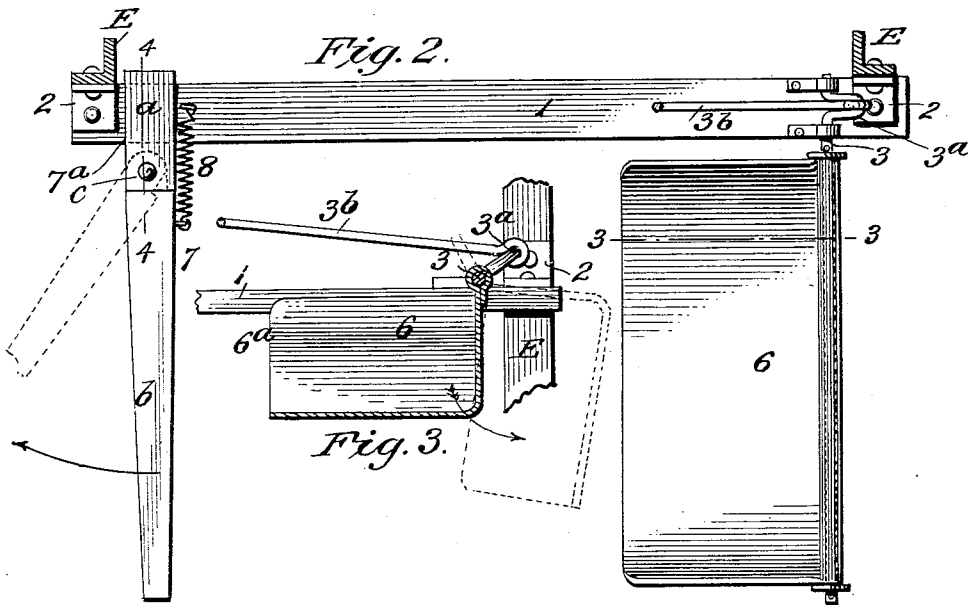
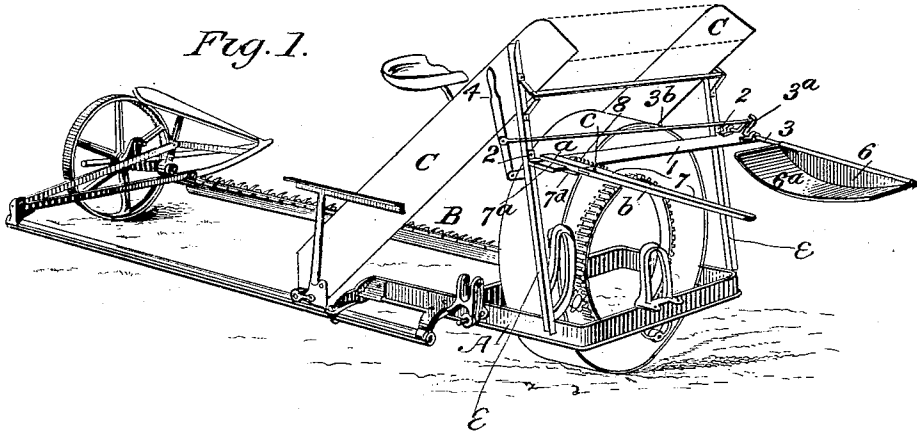

Fig. 3.

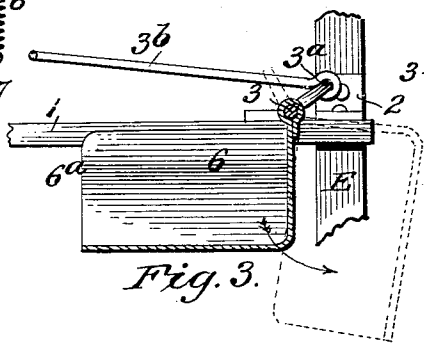
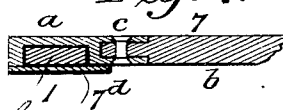

Fig. 4.



WITNESSES:

Louis Dieperich
L. M. Wentzell

INVENTOR

William M Piatt

BY

Fred G. Dietrich & Co.
ATTORNEYS

UNITED STATES PATENT OFFICE.

WILLIAM M. PIATT, OF WEST LIBERTY, OHIO.

EJECTOR ATTACHMENT FOR HARVESTERS.

SPECIFICATION forming part of Letters Patent No. 745,902, dated December 1, 1903.

Application filed August 13, 1902. Serial No. 119,570. (No model.)

To all whom it may concern:

Be it known that I, WILLIAM M. PIATT, residing at West Liberty, in the county of Logan and State of Ohio, have invented a new and Improved Ejector Attachment for Harvesters, of which the following is a specification.

My invention seeks to provide a novel construction of ejector mechanism especially designed for attachment to the ordinary type of harvesters and grain-binders and corn-shockers, and it can be readily applied to the said type of harvesting-machines without materially changing the detailed arrangement of the operating parts thereof.

My invention in its generic nature comprehends an ejector means arranged to be connected to that part of the harvester immediately under the usual binder devices when the said devices are located at the rear of the elevator or at such points where the bound bundle is discharged from the elevator, and it includes in its make-up a vertically-tiltable support for catching and holding the butt-ends of the stalks in bundles, a lever mechanism adapted to be operated from the driver's seat for dumping the said support, and a supporting member for the top end of the shock automatically held in a rigid position while supporting the shock in its horizontal condition and adapted when the shock is dumped to a vertical position to automatically pass over the upper end thereof and resume its normal position after it has passed over said shock.

In its more subordinate features my invention consists in certain details of construction and novel combination of parts, all of which will hereinafter be fully described, and specifically pointed out in the appended claims, reference being had to the accompanying drawings, in which—

Figure 1 is a perspective view of my improvements applied for use, so much of a harvesting-machine being shown as is necessary to illustrate the practical application of my invention. Fig. 2 is a plan view of the attachment. Fig. 3 is a vertical section of the same on the line 3 3 of Fig. 2, the tiltable support being shown dumped to set the shock vertically. Fig. 4 is a transverse section of the hinged sectional supporting member for the

upper end of the shock, taken practically on the line 4 4 of Fig. 2.

In the drawings, A designates the main frame of a harvesting-machine; B, the sickle-bar; C C, the side members of the usual elevator-frame, and E the vertical bars or supports that connect the main frame and the outer end of the elevator-frame members C C, all of said parts being of any approved construction, as they *per se* form no part of my invention.

In the preferred arrangement of a harvester equipped with my improvements the binding apparatus, (not shown,) which may also be of the usual well-known construction, is located at the rear end of the machine and is designed to bind the top of the shock of corn and eject it at the discharge end of the elevator, all of which is accomplished by any well-known means usually employed in harvesting-machines for this purpose.

My improved attachments, as will be readily seen by referring to Fig. 1, are connected to the harvester-frame at such point relatively to the binder so as to receive the elevated shock with the butt-end portions in line with the sickle-bar. The attachment comprises a bar or platform 1, which is disposed in a plane parallel with the elevator and which is made fast to the frame members E E by the angle-plates 2 2 or other suitable means. On the forward end of the supporting member 1 is journaled a rock-shaft 3, disposed transversely of the said member 1 and extended out at right angles from the delivery end of the machine. The shaft 3 has a crank member 3^a, with which connects the link or rod 3^b, that joins with the foot or hand lever 4, disposed adjacent to the driver's seat and in position to be conveniently operated by the driver, as clearly shown in Fig. 1. Upon the outer end of the shaft 3 is fixedly connected a scoop or trough like member 6, concaved in the direction of its length and open at the rear side, as indicated by 6^a, the said open end facing rearwardly for the reason presently explained. At a point to the rear of the trough 6 is mounted a supporting member 7, which is provided for catching and sustaining the upper end of the shock, and the said member 7, which projects outwardly in a plane with the butt-holding member 6, is adjustably se-

cured to the platform or bar 1, whereby it can be moved away from or toward the member 6, as the length of the shock may make necessary.

5 To provide for conveniently moving the member 7 on the bar 1, it is socketed, as at 7^a, to slide on the said bar 1, and it is also provided with a keeper 7^d, as clearly shown in Fig. 4. By thus fitting the member 7 on
10 the bar 1 it can be moved to the position desired. The supporting member 7 is made up of two sections—an inner one, *a*, which is slidably connected to the bar 1, and an outer one, *b*, that joins to the part *a* by a blade-hinge *c*,
15 which is so arranged relatively to the member 6 that the pressure of the shock ends when disposed horizontally or out of a vertical direction will not affect the rigidity of the said support; but when the said shock is dumped
20 to a vertical position and the member *b* engages the said vertically-disposed shock edgewise it will be necessary to contact with the stock and the horizontal pressure thereagainst to be swung backward in a horizontal plane
25 to the position shown in dotted lines in Fig. 2, and by reason thereof pass by the said shock.

A spring 8 is provided for pulling the member *b* back to its normal position when it passes the shock or is relieved from edgewise pressure.
30

From the foregoing, taken in connection with the accompanying drawings, it is believed the advantages of my invention will be readily apparent to those skilled in the art to which it appertains. In the practical operation the butts of the stalks as they pass from the elevator will be received into the scoop or holder 6 and are held thereby as the tops of the stalks are embraced by the binder devices,
40 it being understood the binder devices receive the tops of the stalks from the elevator at the rear of the machine and bind them in the usual manner. After the stalks are bound at the upper end the bound ends are dropped onto the horizontally-swingable arm 7, and after
45 the bound shock is thus caught and supported on the parts 6 and 7 the driver at predetermined times, by a proper manipulation of the foot and hand lever that joins with the crank-shaft 3, that carries the butt-holder 6, rocks the said shaft 3, so as to tilt the member 6 to a vertical position, as indicated in dotted lines in Fig. 3, and thereby allow the unbound end of the shock to fall to the ground, the member
50 7 then serving to bring the said shock to a vertical position. When the shock reaches a vertical position, the pressure on the member 7 will then be directed in the horizontal line, and the member 7, by reason of the said horizontal pressure, will then yield backward (see dotted lines, Fig. 8) and pass back of the upper end of the vertically-disposed shock, after which, on account of its spring tension, the section *b'* of the said member 7 will again
55 resume its normal position, ready to receive the bound end of the next shock, it being understood that at this time the member 6 will

have been returned to its horizontal or normal position.

Slight changes in the details of construction may be made without departing from my invention or the scope of the appended claims.

Having thus described my invention, what I claim, and desire to secure by Letters Patent, is—
75

1. An attachment for harvesters of the character described, comprising a vertically-tiltable support for receiving the unbound or butt ends of a shock, a horizontally-swingable arm for sustaining the bound or head ends of a shock, said arm being automatically swingable by lateral contact with the shock, said vertically-tilted support and said horizontally-swingable arm normally holding
80 the shock in a horizontal position; means for tilting the tiltable support to discharge the unbound or butt ends of the shock, so that the said shock will assume a vertical position for the purposes specified.
90

2. The combination with the shock-delivery end of a harvester; of a supporting member secured thereon in a plane below the point of discharge of the bound shock, a vertically-tiltable support mounted on one end of the supporting member to receive the butt-ends
95 of the shock, a horizontally-swingable supporting-arm mounted on the supporting member, and disposed to receive the heads or tops of the shock, a lever mechanism for tilting the butt-holding support, whereby to dump the shock to a vertical position, the said horizontally-swingable arm being arranged to swing back by endwise contact with the shock, when the latter is set in a vertical position,
105 and automatically returnable to its normal position when it passes over the shock, as set forth.

3. In a harvester, a shock catching and setting mechanism, comprising a supporting member disposed in a plane below the shock-ejector end of the harvester, a rock-shaft journaled on one end thereof, and projected outwardly at right angles thereto, and in the same longitudinal direction as the sickle-bar,
110 an open-end scoop-like member secured to the rock-shaft, a lever mechanism for tilting the rock-shaft to bring the scoop-like member to a vertical position, an arm secured to the other end of the supporting member, and projected at right angles therefrom, said arm being disposed relatively to the ejector end of the harvester to catch the heads or top ends of the shock, and the said arm including a pivotal member rearwardly swingable in a horizontal plane, means for normally holding said pivotal member to its shock-supporting position, said member being arranged to swing rearwardly automatically when its edge engages the dumped
120 shock, as set forth.
125

4. A shock catcher and setting mechanism, comprising means for catching the shock and sustaining it in a horizontal plane as it is

ejected from the discharge or binder end of the machine, said means comprising a vertically-tiltable support for sustaining the butt-end of the shock, means for tilting the said support, an arm for sustaining the head or top end of the shock rigidly supported when the shock lies horizontally thereon, and provided with the horizontally and rearwardly swinging member adapted to be moved back to pass over the upper end of the shock by engagement with the said shock when the latter is in its vertical position.

WILLIAM M. PIATT.

Witnesses:

R. N. JORDAN,
ROE THOMPSON.