



US011664345B2

(12) **United States Patent**
Ho et al.

(10) **Patent No.:** **US 11,664,345 B2**
(45) **Date of Patent:** **May 30, 2023**

(54) **SEMICONDUCTOR PACKAGE ELEMENT**

- (71) Applicant: **PANJIT INTERNATIONAL INC.**,
Kaohsiung (TW)
- (72) Inventors: **Chung-Hsiung Ho**, Kaohsiung (TW);
Chih-Hung Chang, Kaohsiung (TW);
Chi-Hsueh Li, Tainan (TW)
- (73) Assignee: **PANJIT INTERNATIONAL INC.**,
Kaohsiung (TW)

(*) Notice: Subject to any disclaimer, the term of this patent is extended or adjusted under 35 U.S.C. 154(b) by 24 days.

(21) Appl. No.: **17/353,836**

(22) Filed: **Jun. 22, 2021**

(65) **Prior Publication Data**
US 2022/0406750 A1 Dec. 22, 2022

(51) **Int. Cl.**
H01L 23/00 (2006.01)
H01L 23/31 (2006.01)
H01L 21/56 (2006.01)

(52) **U.S. Cl.**
CPC **H01L 24/96** (2013.01); **H01L 21/561**
(2013.01); **H01L 23/3114** (2013.01); **H01L**
24/97 (2013.01); **H01L 2224/04105** (2013.01);
H01L 2224/48091 (2013.01); **H01L 2924/014**
(2013.01); **H01L 2924/181** (2013.01)

(58) **Field of Classification Search**
None
See application file for complete search history.

(56) **References Cited**

U.S. PATENT DOCUMENTS

- 10,134,687 B1 * 11/2018 Kim H01L 24/73
- 2013/0181338 A1 * 7/2013 Lu H01L 23/3157
257/737
- 2016/0035663 A1 * 2/2016 Huang H01L 23/49861
257/668
- 2018/0151478 A1 * 5/2018 Chen H01L 21/561

FOREIGN PATENT DOCUMENTS

TW 202109782 A 3/2021

* cited by examiner

Primary Examiner — Jay C Chang

(74) *Attorney, Agent, or Firm* — Winston Hsu

(57) **ABSTRACT**

A semiconductor package element includes a die, a passive layer, a conductive structure and an encapsulation layer. The die includes a first surface, a second surface and a third surface. The second surface is opposite to the first surface. The third surface is connected between the first surface and the second surface. The passive layer is disposed on the first surface and formed with a hole. The conductive structure is electrically coupled to the die through the hole. The encapsulation layer covers the first surface and the third surface of the die, wherein the passive layer is embedded in the encapsulation layer, a portion of the conductive structure is embedded in the encapsulation layer, and the other portion of the conductive structure protrudes from an etched surface of the encapsulation layer, the etched surface is formed by plasma etching.

6 Claims, 8 Drawing Sheets

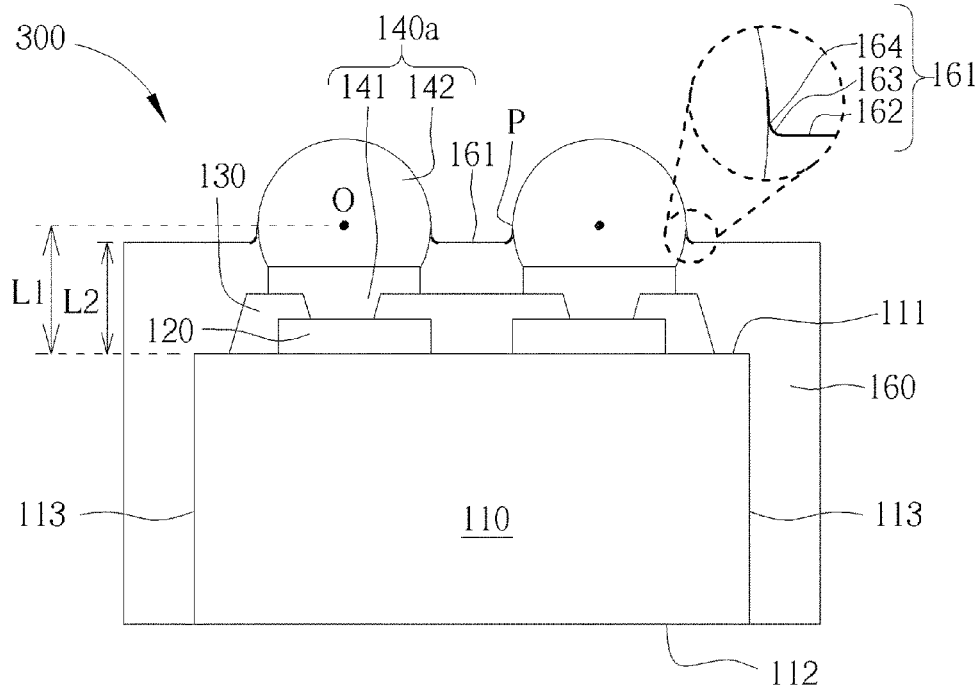

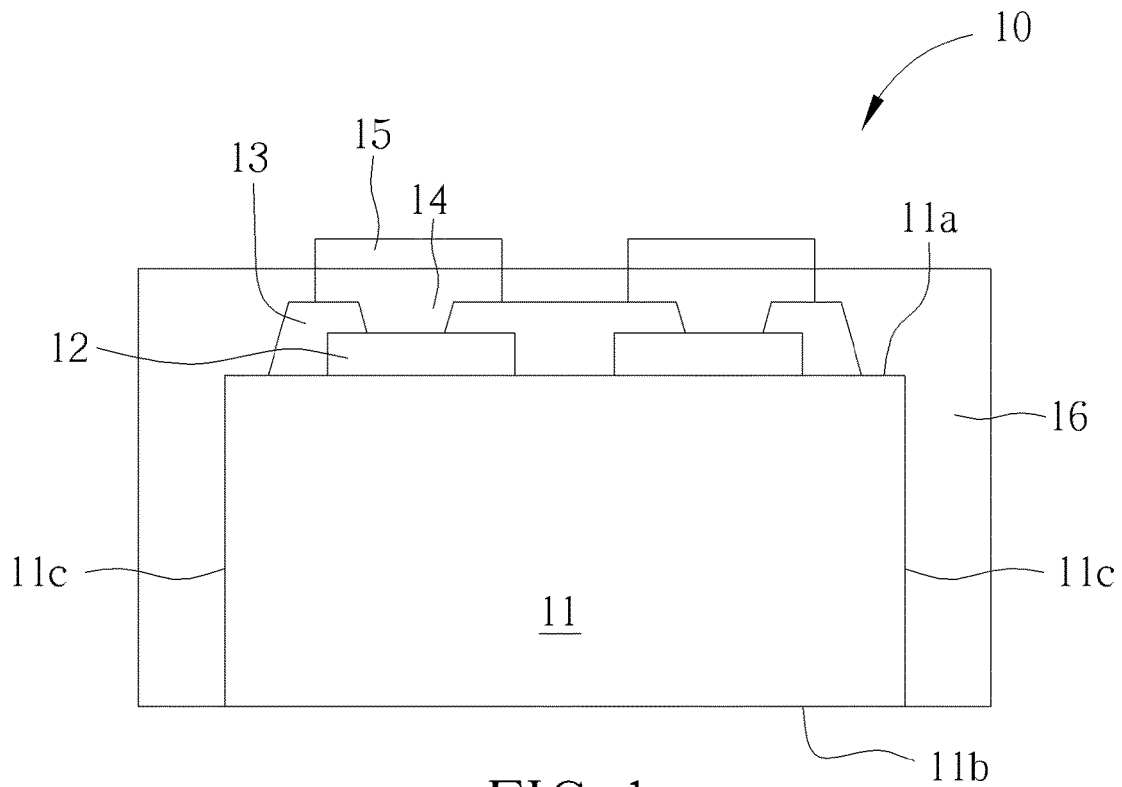

FIG. 1

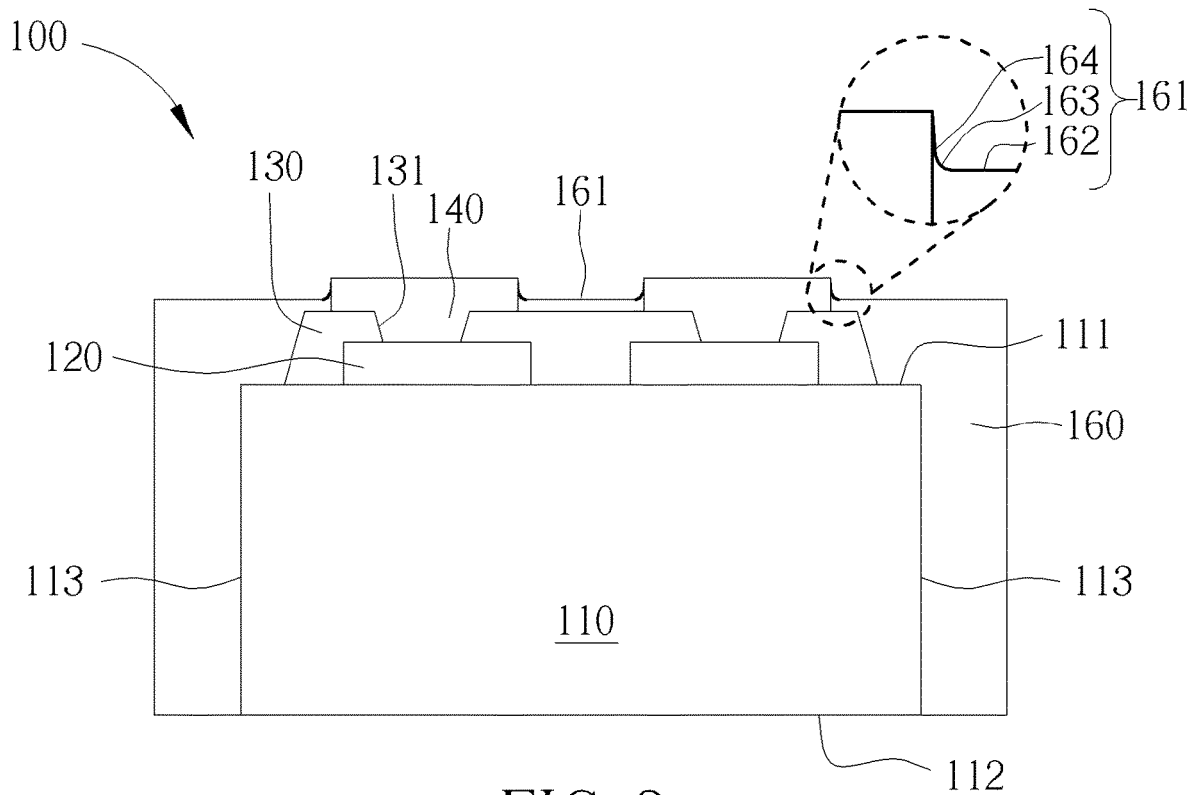

FIG. 2

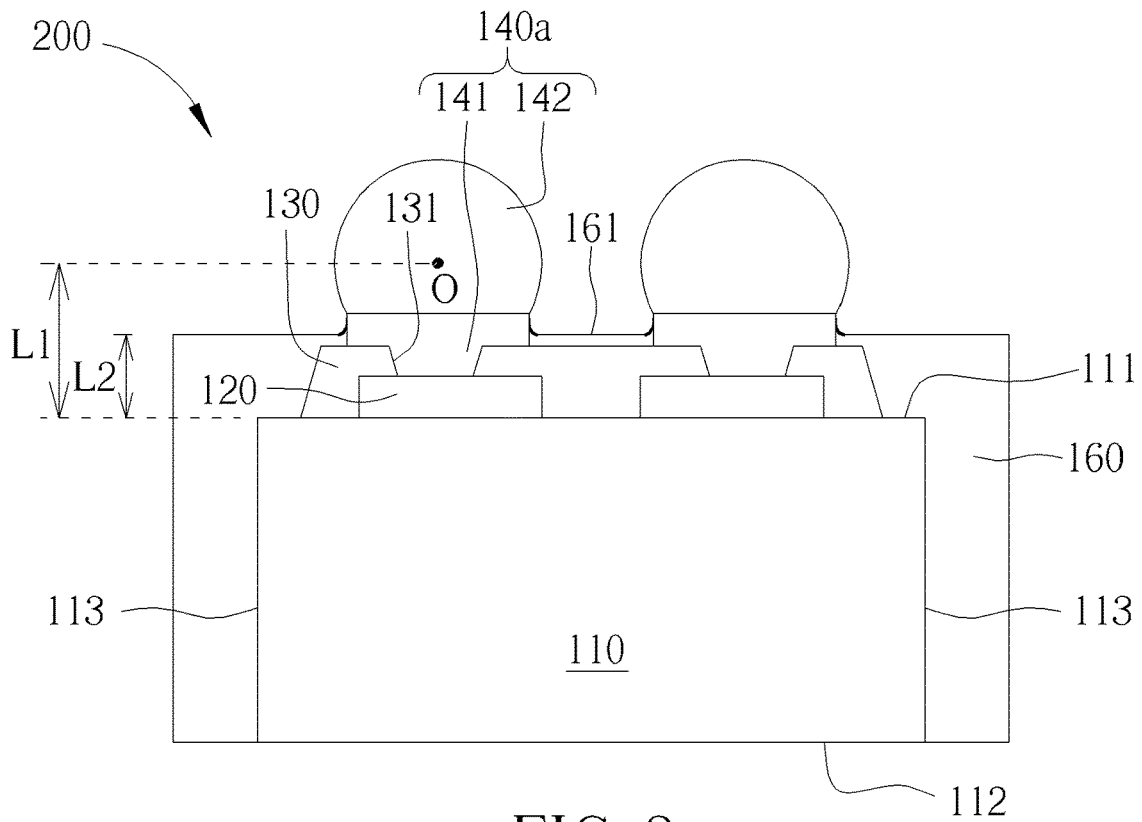

FIG. 3

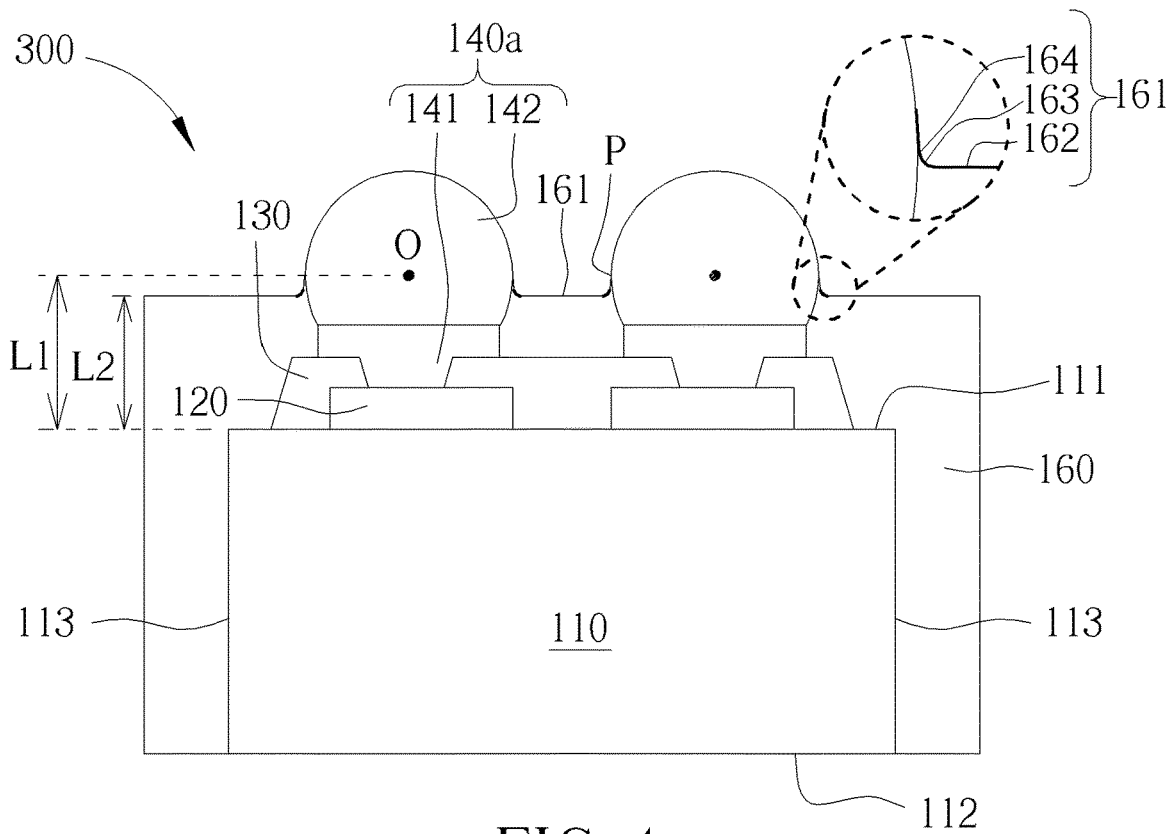
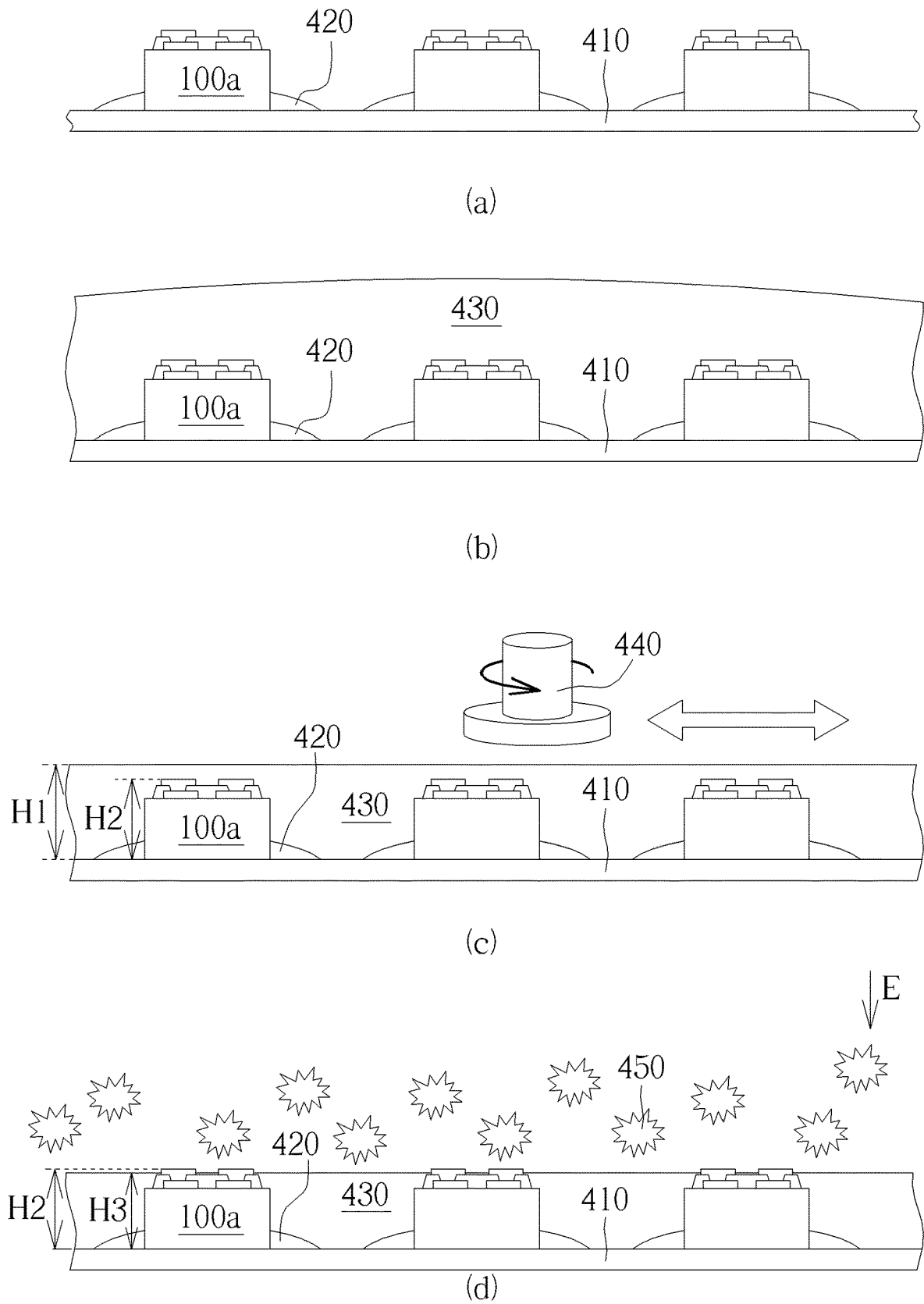
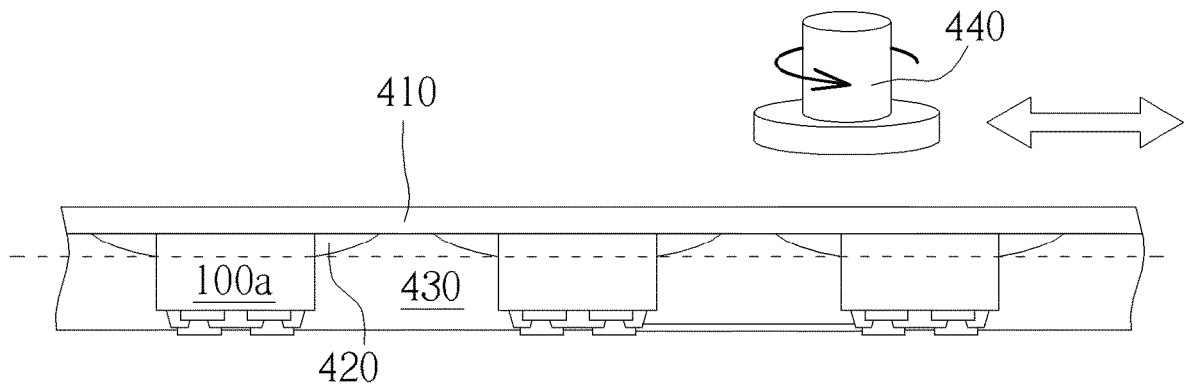
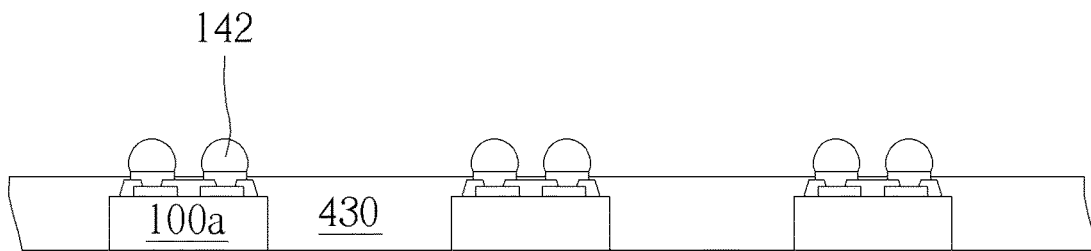

FIG. 4





(a)



(b)

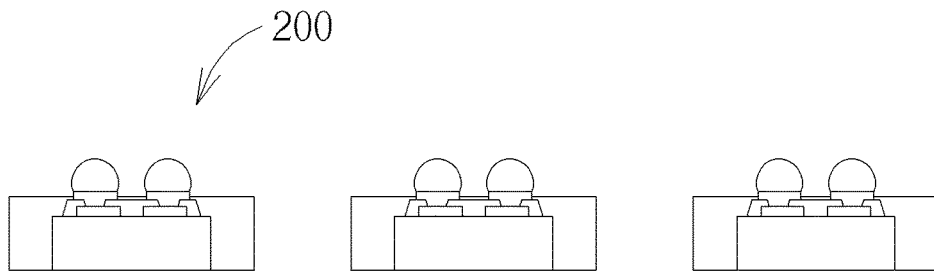

(c)

FIG. 6

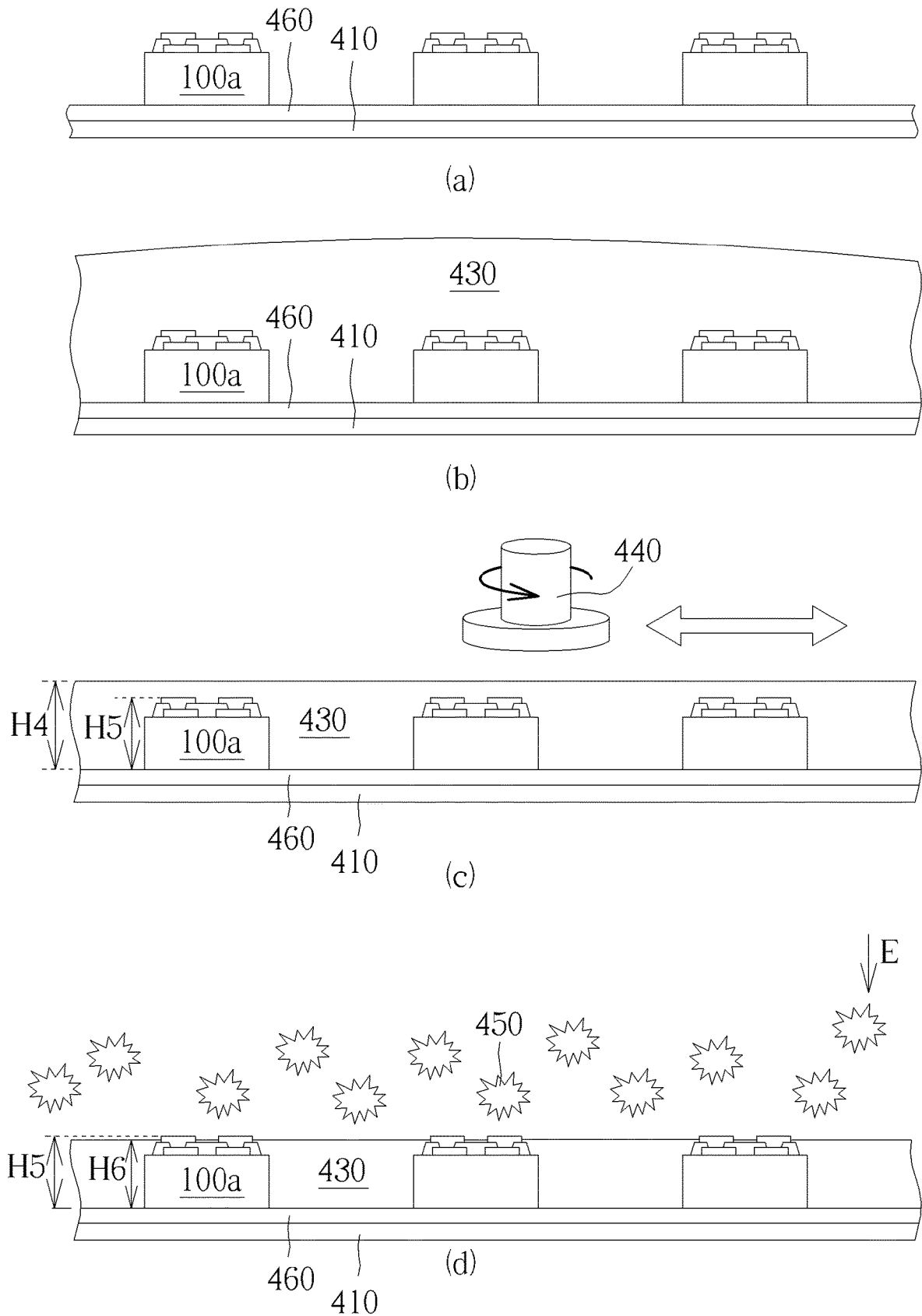
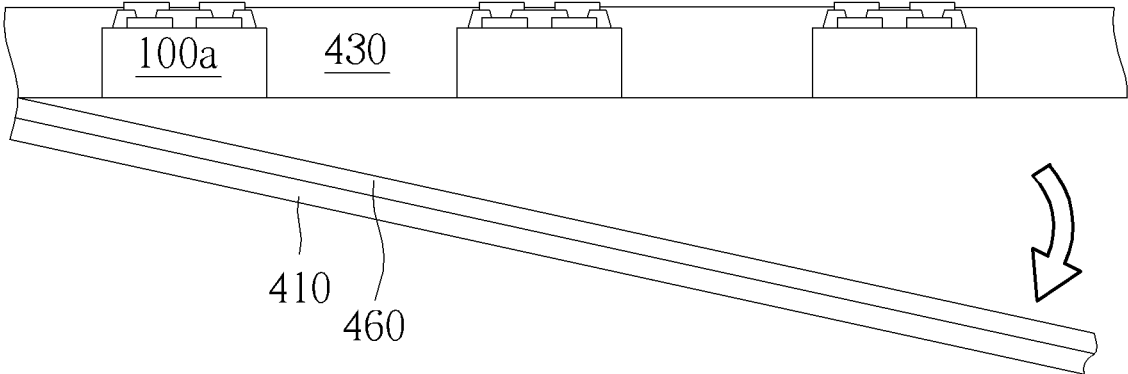
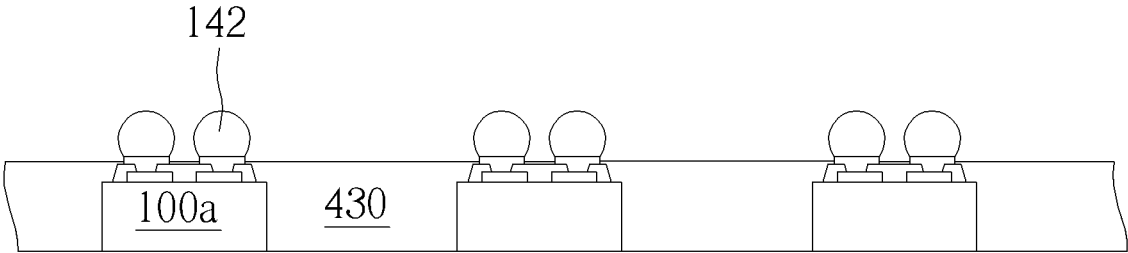

FIG. 7



(a)



(b)

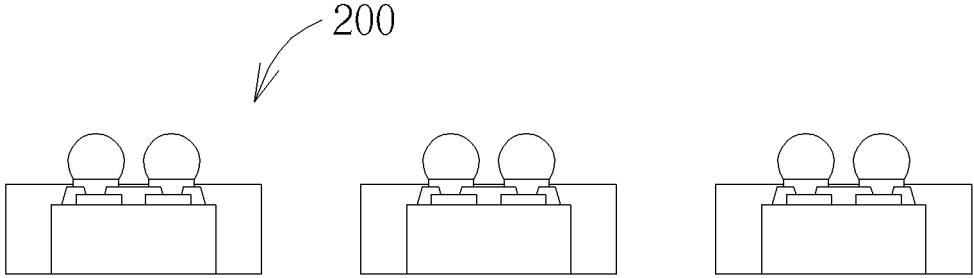

(c)

FIG. 8

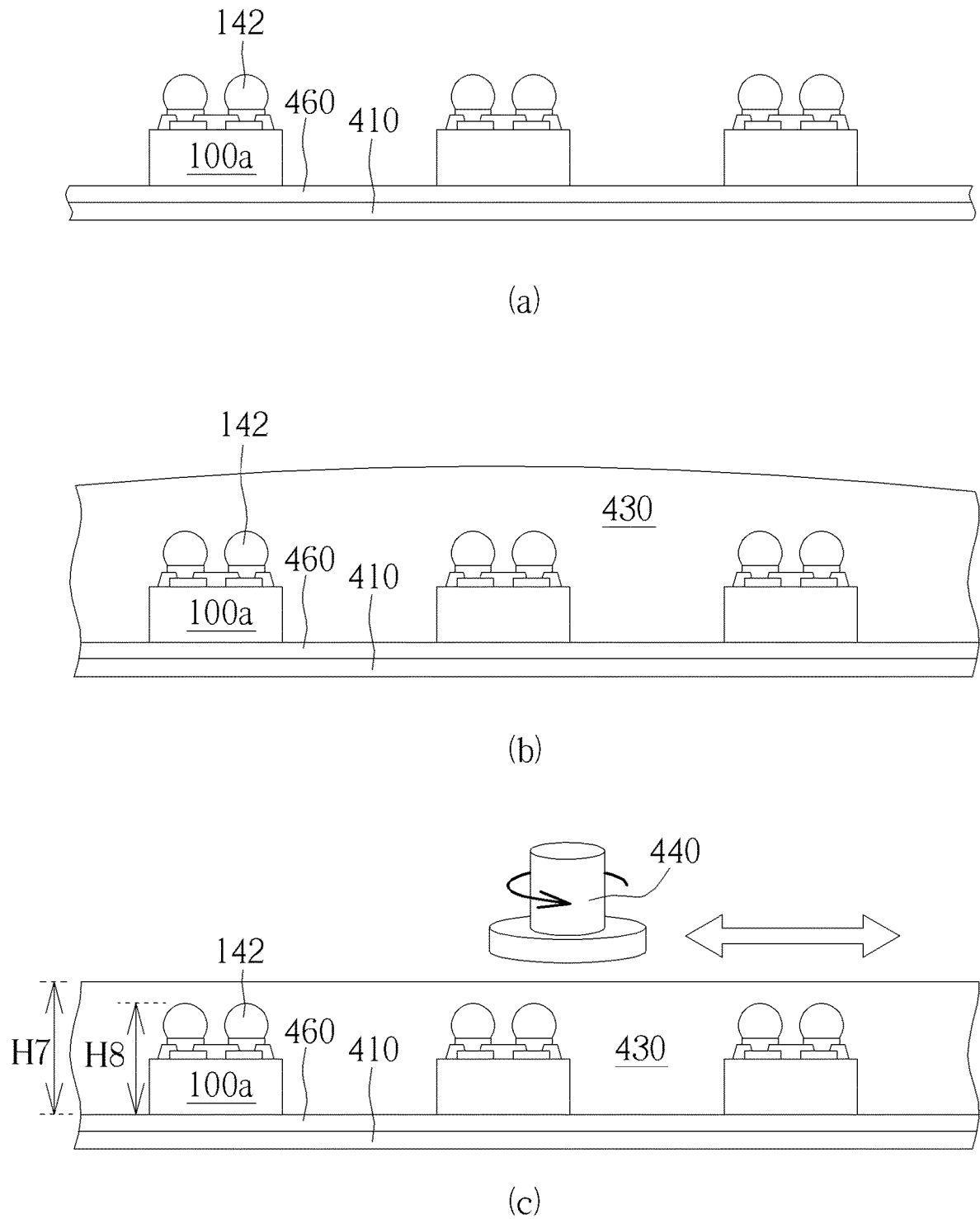

FIG. 9

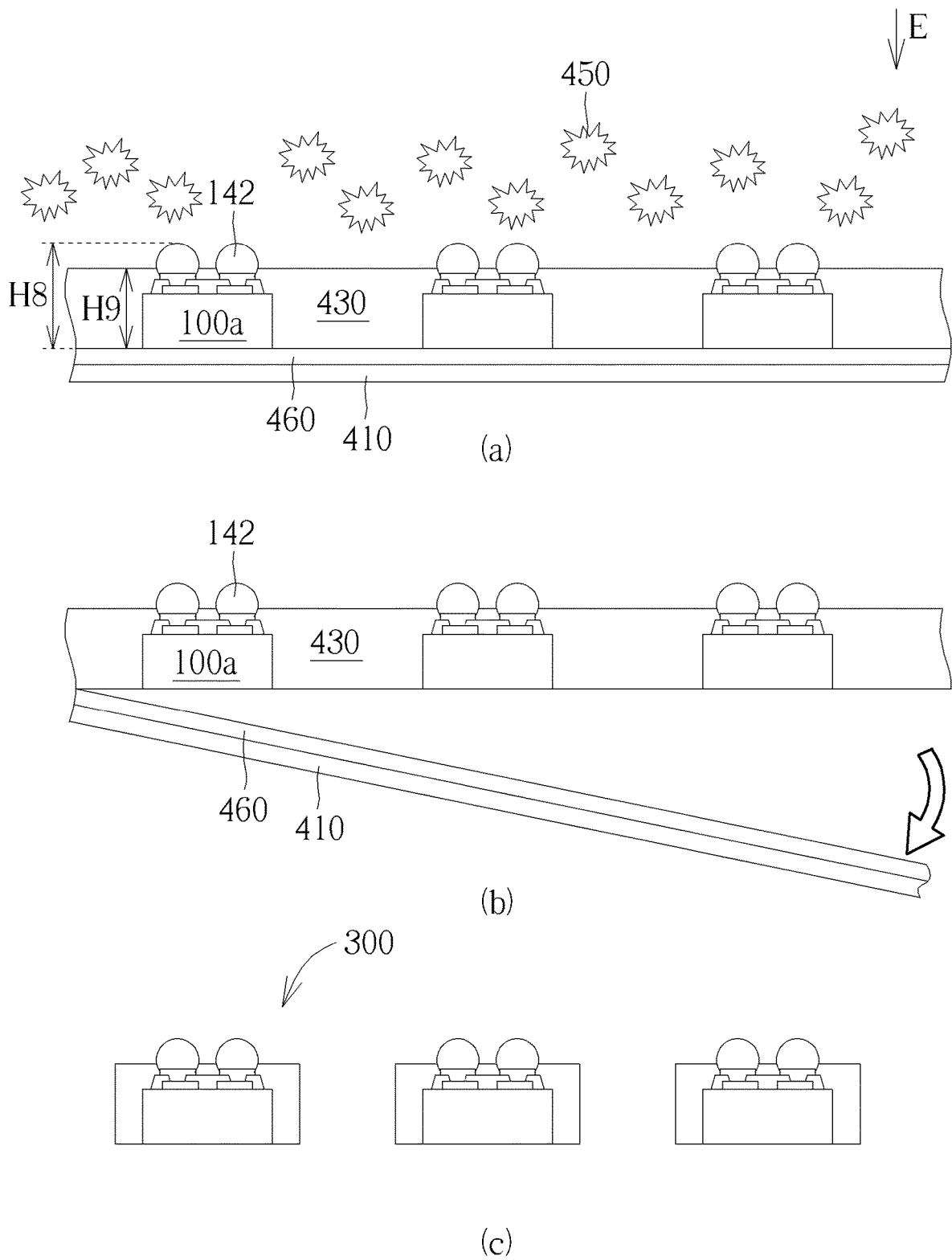

FIG. 10

SEMICONDUCTOR PACKAGE ELEMENT

BACKGROUND OF THE INVENTION

1. Field of the Invention

The present disclosure relates to a semiconductor package element, and more particularly, to a semiconductor package element in which an encapsulating material above a conductive structure is removed by plasma etching to expose the conductive structure.

2. Description of the Prior Art

With the development of miniaturization of semiconductor die, high-end microelectronic packaging technology is developing from lead frame and wire bonding toward bumps.

Please refer to FIG. 1, which is a cross-sectional view showing a conventional semiconductor package element **10** with bumps **15**. The method for manufacturing the semiconductor package element **10** is as follows. First, two metal pads **12**, a passive layer **13** and two copper pillars **14** are sequentially formed on a first surface **11a** of the die **11**, and then the third surface **11c**, the first surface **11a**, the passive layer **13** and the copper pillars **14** on the first surface **11a** of the die **11** are completely encapsulated with an encapsulating material. After the encapsulating material is cured, through a grinding process, such as a chemical mechanical planarization process, the encapsulating material and the copper pillars **14** are grind, such that the encapsulating material and the copper pillars **14** are equal in height and the copper pillars **14** are exposed. Afterwards, bumps **15** are formed on the copper pillars **14**, and the remaining encapsulating material is the encapsulation layer **16**.

However, during the grinding process, surface burrs, surface scratches and residual stresses may generate on the copper pillar **14**, which affects the performance of the semiconductor package element **10**. Furthermore, the hardness of copper pillar **14** is high, which will reduce the life of the grinding tool. In addition, the copper pillars **14** need to reserve a height for grinding, which requires a longer process time and higher material costs.

SUMMARY OF THE INVENTION

According to an embodiment of the present disclosure, a semiconductor package element includes a die, a passive layer, a conductive structure and an encapsulation layer. The die includes a first surface, a second surface and a third surface. The second surface is opposite to the first surface. The third surface is connected between the first surface and the second surface. The passive layer is disposed on the first surface and formed with a hole. The conductive structure is electrically coupled to the die through the hole. The encapsulation layer covers the first surface and the third surface of the die, wherein the passive layer is embedded in the encapsulation layer, a portion of the conductive structure is embedded in the encapsulation layer, and the other portion of the conductive structure protrudes from an etched surface of the encapsulation layer. The etched surface is formed by plasma etching.

These and other objectives of the present invention will no doubt become obvious to those of ordinary skill in the art after reading the following detailed description of the preferred embodiment that is illustrated in the various figures and drawings.

BRIEF DESCRIPTION OF THE DRAWINGS

FIG. 1 is a cross-sectional view showing a conventional semiconductor package element with bumps.

FIG. 2 is a cross-sectional view showing a semiconductor package element according to one embodiment of the present disclosure.

FIG. 3 is a cross-sectional view showing a semiconductor package element according to another embodiment of the present disclosure.

FIG. 4 is a cross-sectional view showing a semiconductor package element according to yet another embodiment of the present disclosure.

FIG. 5 and FIG. 6 are schematic diagrams showing a manufacturing process of a semiconductor package element according to one embodiment of the present disclosure.

FIG. 7 and FIG. 8 are schematic diagrams showing a manufacturing process of a semiconductor package element according to another embodiment of the present disclosure.

FIG. 9 and FIG. 10 are schematic diagrams showing a manufacturing process of a semiconductor package element according to yet another embodiment of the present disclosure.

DETAILED DESCRIPTION

In the following detailed description of the embodiments, reference is made to the accompanying drawings which form a part thereof, and in which is shown by way of illustration specific embodiments in which the disclosure may be practiced. In this regard, directional terminology, such as up, down, left, right, front, back, etc., is used with reference to the orientation of the Figure (s) being described. As such, the directional terminology is used for purposes of illustration and is in no way limiting. In addition, identical numeral references or similar numeral references are used for identical elements or similar elements in the following embodiments.

According to the present disclosure, when two elements are substantially parallel to each other, it refers that an angle is between the two elements, and the angle is 0 ± 10 degrees. Alternatively, the angle is 180 ± 10 degrees. When two elements are substantially perpendicular to each other, it refers that an angle is between the two elements, and the angle is 90 ± 10 degrees.

Please refer to FIG. 2, which is a cross-sectional view showing a semiconductor package element **100** according to one embodiment of the present disclosure. The semiconductor package element **100** includes a die **110**, a passive layer **130**, two conductive structures **140** and an encapsulation layer **160**.

The die **110** is a semiconductor die, such as a logic die and a memory die. The die **110** includes a first surface **111**, a second surface **112** and a third surface **113**. The second surface **112** is opposite to the first surface **111**. The third surface **113** is connected between the first surface **111** and the second surface **112**. Two metal pads **120** can be disposed on the first surface **111**. The metal pads **120**, such as aluminum pads, are used as input/output pads (I/O pad) of the die **110**.

The passive layer **130** is disposed on the first surface **111** and formed with two holes **131**. The material of the passive layer **130** can be epoxy resin or polyimide. The passive layer **130** can be formed on the first surface **111** by spin coating, lamination, etc. The holes **131** can be formed by exposure and development technology.

Each of the conductive structures **140** is electrically coupled to the die **110** through the hole **131**. In the embodiment, the conductive structure **140** can be a metal layer and disposed on the metal pad **120** directly. In other embodiment, a re-distribution layer (RDL) can be disposed between the conductive structure **140** and the metal pad **120**. The material of the metal layer can be nickel, copper or a combination thereof. The metal layer can be formed by evaporation or sputtering.

The encapsulation layer **160** covers the first surface **111** and the third surface **113** of the die **110**, wherein the passive layer **130** is embedded in the encapsulation layer **160**, a portion of the conductive structure **140** is embedded in the encapsulation layer **160**, and the other portion of the conductive structure **140** protrudes from an etched surface **161** of the encapsulation layer **160**. The etched surface **161** is formed by plasma etching. The material of the encapsulation layer **160** can be a dielectric material, such as polypropylene or epoxy molding compound (EMC). With the encapsulation layer **160**, the die **110** can be provided with the ability to withstand impact. The phrase "the etched surface **161** is formed by plasma etching" means that the encapsulating material forming the encapsulation layer **160** completely covers the first surface **111** of the die **110**, the passive layer **130** and the conductive structures **140** in the beginning, the portion of the encapsulating material above the conductive structure **140** is removed by plasma etching, such that the conductive structure **140** is exposed, and the remaining encapsulating material is the encapsulation layer **160**. The surface of the encapsulation layer **160** etched by the plasma is the etched surface **161**. Since the plasma etching is directional, the plasma etching has an etching direction (which can refer to an etching direction E in the part (d) of FIG. 5) substantially perpendicular to the first surface **111**. The etched surface **161** can include a first etched portion **162**, a second etched portion **163** and a third etched portion **164**. The third etched portion **164** is connected between the conductive structure **140** and the second etched portion **163**. The second etched portion **163** is connected between the third etched portion **164** and the first etched portion **162**, i.e., the second etched portion **163** is located between the conductive structure **140** and the first etched portion **162**. The first etched portion **162** is substantially perpendicular to the etching direction. The third etched portion **164** is substantially parallel to the etching direction. A cross section of the second etched portion **163** is an arc. That is, a substantially vertical etching contour can be obtained by plasma etching. By using plasma etching to remove the encapsulating material above the conductive structure **140**, the drawbacks of the conventional grinding process can be avoided.

Please refer to FIG. 3, which is a cross-sectional view showing a semiconductor package element **200** according to another embodiment of the present disclosure. Compared with the semiconductor package element **100** in FIG. 2, the conductive structure **140a** includes a metal layer **141** (herein, an under-bump metallization layer) and a bump **142**. The metal layer **141** is disposed above the first surface **111**, and the bump **142** is disposed above the metal layer **141**. The bump **142** defines a geometric center O, a distance L1 between the geometric center O and the first surface **111** is greater than a distance L2 between the etched surface **161** and the first surface **111**. Herein, the bump **142** is exemplary a solder ball, and the geometric center O is a ball center of the solder ball.

Please refer to FIG. 4, which is a cross-sectional view showing a semiconductor package element **300** according to yet another embodiment of the present disclosure. The

difference between the semiconductor package element **200** in FIG. 3 and the semiconductor package element **300** in FIG. 4 is the height of the etched surface **161** (herein the height of the etched surface **161** is represented by the height of the first etched portion **162** with larger area). In FIG. 3, the etched surface **161** is aligned with the metal layer **141**. In FIG. 4, the etched surface **161** is aligned with the bump **142**. Specifically, when manufacturing the semiconductor package element **200**, the encapsulation layer **160** can be formed firstly and then the bumps **142** are formed. Therefore, the encapsulation layer **160** does not cover the bumps **142**. When manufacturing the semiconductor package element **300**, the bumps **142** are formed firstly and then the encapsulation layer **160** is formed. Therefore, the encapsulation layer **160** can encapsulate a portion of the bumps **142**. For other details, references can be made to the related description of FIG. 5 to FIG. 10. When each of the bumps **142** is a solder ball, and a distance L1 between the geometric center O (i.e., the ball center) and the first surface **111** is greater than or equal to a distance L2 between the etched surface **161** and the first surface **111**, a height of the connection point P of the third etched portion **164** and the solder ball is substantially equal to a height of the ball center. The structural feature is resulted in the etching direction of plasma etching being downward, and the solder ball having a largest lateral length at the ball center. Therefore, the encapsulating material below the point P cannot be etched by the plasma.

Please refer to FIG. 5 and FIG. 6, which are schematic diagrams showing a manufacturing process of a semiconductor package element according to one embodiment of the present disclosure, and can be applied to manufacture the semiconductor package element **200** in FIG. 3.

In the part (a) of FIG. 5, a plurality of independent and unpackaged first elements **100a** are fixed on a substrate **410**, such as fixed on the substrate **410** through the glue **420**. Each of the first element **100a** includes a die **110**, two metal pads **120**, a passive layer **130** and two metal layers **141** (shown in FIG. 3). The substrate **410** can be a wafer or a panel. The material of the panel can be glass, ceramic or other supporting materials. The shape of the substrate **410** can be an arbitrary shape, such as a circle or a rectangle. In the part (b) of FIG. 5, the first elements **100a** are completely encapsulated with the encapsulating material **430**, such as by dispensing and printing. Then the encapsulating material **430** is cured. In the part (c) of FIG. 5, a portion of the encapsulating material **430** is initially removed, in which a grinding tool **440** can be used to grind the encapsulating material **430**, such that a height H1 of the encapsulating material **430** is slightly higher than a height H2 of the first element **100a**. In the part (d) of FIG. 5, a portion of the encapsulating material **430** is removed by plasma etching, such that a height H3 of the encapsulating material **430** is lower than the height H2 of the first element **100a**, and the metal layers **141** are exposed. The etching direction E of the plasma **450** E is downward and perpendicular to the first surface **111** or the substrate **410**. The gas used in plasma etching depends on the encapsulating material **430**. For example, the gas can be oxygen, carbon tetrafluoride, or a combination thereof.

In the part (a) of FIG. 6, the substrate **410** is removed. For example, the substrate **410** can be removed by grinding with the grinding tool **440**, and the glue **420** can be removed by further grinding to the dotted line. In the part (b) of FIG. 6, the bumps **142** are formed. The bumps **142** can be formed by a ball drop process. Alternatively, a tin layer can be firstly formed by evaporation, printing, etc., and then a reflow process is performed to obtain the bumps **142** with desired

5

shapes. In the part (c) of FIG. 6, a sawing step is performed, such that a plurality of independent semiconductor package elements **200** are obtained, and the remaining encapsulating material **430** is the encapsulation layer **160**. In other embodiment, when the step shown in the part (b) of FIG. 6 is omitted, the semiconductor package element **100** in FIG. 2 can be obtained.

Please refer to FIG. 7 and FIG. 8, which are schematic diagrams showing a manufacturing process of a semiconductor package element according to another embodiment of the present disclosure, and can be applied to manufacture the semiconductor package element **200** in FIG. 3.

In the part (a) of FIG. 7, a plurality of independent and unpackaged first elements **100a** are fixed on the substrate **410**, such as fixed on the substrate **410** through a thermal release film **460**. In the part (b) of FIG. 7, the first elements **100a** are completely encapsulated with the encapsulating material **430**. In the part (c) of FIG. 7, a portion of the encapsulating material **430** is initially removed, such that a height **H4** of the encapsulating material **430** is slightly higher than a height **H5** of the first element **100a**. In the part (d) of FIG. 7, a portion of the encapsulating material **430** is removed by plasma etching, such that a height **H6** of the encapsulating material **430** is lower than the height **H5** of the first element **100a**, and the metal layers **141** are exposed.

In the part (a) of FIG. 8, the substrate **410** is removed. For example, the viscosity of the thermal release film **460** can be reduced by heating, and the thermal release film **460** together with the substrate **410** can be easily peeled off. In the part (b) of FIG. 8, the bumps **142** are formed. In the part (c) of FIG. 8, a sawing step is performed, such that a plurality of independent semiconductor package elements **200** are obtained. For details of FIG. 7 and FIG. 8, references can be made to the related description of FIG. 5 and FIG. 6.

Please refer to FIG. 9 and FIG. 10, which are schematic diagrams showing a manufacturing process of a semiconductor package element according to yet another embodiment of the present disclosure, and can be applied to manufacture the semiconductor package element **300** in FIG. 4. Compared to FIG. 7 and FIG. 8, the bumps **142** are firstly formed on each of the first element **100a** in FIG. 9 and FIG. 10. Hereinafter, the combination of the bumps **142** and the first element **110a** is called as the second element (not labeled).

In the part (a) of FIG. 9, a plurality of independent and unpackaged second elements are fixed on the substrate **410**. In the part (b) of FIG. 9, the second elements are completely encapsulated with the encapsulating material **430**. In the part (c) of FIG. 9, a portion of the encapsulating material **430** is initially removed, such that a height **H7** of the encapsulating material **430** is slightly higher than a height **H8** of the second element.

In the part (a) of FIG. 10, a portion of the encapsulating material **430** is removed by plasma etching, such that a height **H9** of the encapsulating material **430** is lower than the height **H8** of the second element, and the bumps **142** are exposed. In the part (b) of FIG. 10, the substrate **410** is removed. In the part (c) of FIG. 10, a sawing step is performed, such that a plurality of independent semiconductor package elements **300** are obtained. In the embodiment, since the bumps **142** are formed firstly, and then the encapsulation layer **160** is formed, the encapsulation layer **160** can cover a portion of each of the bumps **142**. In addition, the exposed height of each of the bumps **142** can be determined by controlling the parameters of plasma etching. When the depth of plasma etching is deeper, and the height **H9** of the encapsulating material **430** is lowered to

6

align with the metal layer **141**, the semiconductor package element **200** in FIG. 3 can be obtained. For details of FIG. 9 and FIG. 10, references can be made to the related description of FIG. 5 to FIG. 8.

According to another embodiment of the present disclosure, a method **500** for manufacturing a semiconductor package element is disclosed. The method **500** includes Steps **510** to **580**, in which Steps **530**, **560** and **570** are optional.

In Step **510**, a plurality of independent and unpackaged elements are fixed on a substrate.

In Step **520**, the elements are completely encapsulated with an encapsulating material.

In Step **530**, a portion of the encapsulating material is removed by a grinding tool.

In Step **540**, a portion of the encapsulating material is removed by plasma etching, such that a conductive structure of each of the elements is exposed.

In Step **550**, the substrate is removed.

In Step **560**, a laser marking step is performed, such that information, such as specifications and manufacturer are indicated on the die.

In Step **570**, a plurality of bumps are formed.

In Step **580**, a sawing step is performed, such that a plurality of independent semiconductor package elements are obtained.

Compared to the prior art, the semiconductor package element of the present disclosure has advantages as follows.

First, the semiconductor package element has a conductive structure, and does not require the traditional lead frames, substrates and wire bonding, which is beneficial to the development of miniaturization. Second, the encapsulating material above the conductive structure is removed by plasma etching, which can avoid surface burrs, surface scratches and residual stress generated on the conductive structure due to grinding, and can extend the life of the grinding tool. Third, the conductive structure does not need to reserve a height for grinding, which can save process time and material costs. Fourth, according to the present disclosure, a plurality of dies are packaged at the same time then are divided by sawing, which is applicable for wafer level package and panel level package. Fifth, according to the present disclosure, the element is completely encapsulated with an encapsulating material, and then the upper encapsulating material is removed, which is beneficial to improve the structural strength of the package.

Those skilled in the art will readily observe that numerous modifications and alterations of the device and method may be made while retaining the teachings of the invention. Accordingly, the above disclosure should be construed as limited only by the metes and bounds of the appended claims.

What is claimed is:

1. A semiconductor package element, comprising:
 - a die, comprising:
 - a first surface;
 - a second surface opposite to the first surface; and
 - a third surface connected between the first surface and the second surface;
 - a passive layer disposed on the first surface and formed with a hole;
 - a conductive structure electrically coupled to the die through the hole, wherein the conductive structure comprises a metal layer and a bump, the metal layer is disposed above the first surface, and the bump is disposed above the metal layer; and

an encapsulation layer covering the first surface and the third surface of the die, wherein the passive layer is embedded in the encapsulation layer, a portion of the conductive structure is embedded in the encapsulation layer, another portion of the conductive structure protrudes from an etched surface of the encapsulation layer, the etched surface is formed by plasma etching, the etched surface directly connects a sidewall of the metal layer, the etched surface comprises a first etched portion and a second etched portion, the second etched portion is located between the conductive structure and the first etched portion, and a cross section of the second etched portion is an arc.

2. The semiconductor package element of claim 1, wherein the plasma etching has an etching direction, the first etched portion is substantially perpendicular to the etching direction.

3. The semiconductor package element of claim 2, wherein the etched surface further comprises a third etched portion connected between the conductive structure and the second etched portion, the third etched portion is substantially parallel to the etching direction.

4. The semiconductor package element of claim 1, wherein the bump defines a geometric center, a distance between the geometric center and the first surface is greater than or equal to a distance between the etched surface and the first surface.

- 5. A semiconductor package element, comprising:
 - a die, comprising:
 - a first surface;
 - a second surface opposite to the first surface; and
 - a third surface connected between the first surface and the second surface;
 - a passive layer disposed on the first surface and formed with a hole;
 - a conductive structure electrically coupled to the die through the hole, wherein the conductive structure comprises a metal layer and a bump, the metal layer is disposed above the first surface, and the bump is disposed above the metal layer; and

an encapsulation layer covering the first surface and the third surface of the die, wherein the passive layer is embedded in the encapsulation layer, a portion of the conductive structure is embedded in the encapsulation

layer, another portion of the conductive structure protrudes from an etched surface of the encapsulation layer, the etched surface is formed by plasma etching, the etched surface directly connects a sidewall of the conductive structure, the bump defines a geometric center, a distance between the geometric center and the first surface is greater than or equal to a distance between the etched surface and the first surface, the bump is a solder ball, the geometric center is a ball center of the solder ball, the etched surface includes a first etched portion, a second etched portion and a third etched portion, the third etched portion is connected between the conductive structure and the second etched portion, the second etched portion is connected between the third etched portion and the first etched portion, and a height of a connection point of the third etched portion and the solder ball is substantially equal to a height of the ball center.

- 6. A semiconductor package element, comprising:
 - a die, comprising:
 - a first surface;
 - a second surface opposite to the first surface; and
 - a third surface connected between the first surface and the second surface;
 - a passive layer disposed on the first surface and formed with a hole;
 - a conductive structure electrically coupled to the die through the hole, wherein the conductive structure comprises a solder ball; and
 - an encapsulation layer covering the first surface and the third surface of the die, wherein the passive layer is embedded in the encapsulation layer, a portion of the conductive structure is embedded in the encapsulation layer, and another portion of the conductive structure protrudes from an etched surface of the encapsulation layer, the etched surface is formed by plasma etching, the etched surface comprises a third etched portion substantially parallel to a normal of the first surface, and a height of a connection point of the third etched portion and the conductive structure is substantially equal to or less than a height of a ball center of the solder ball.

* * * * *