

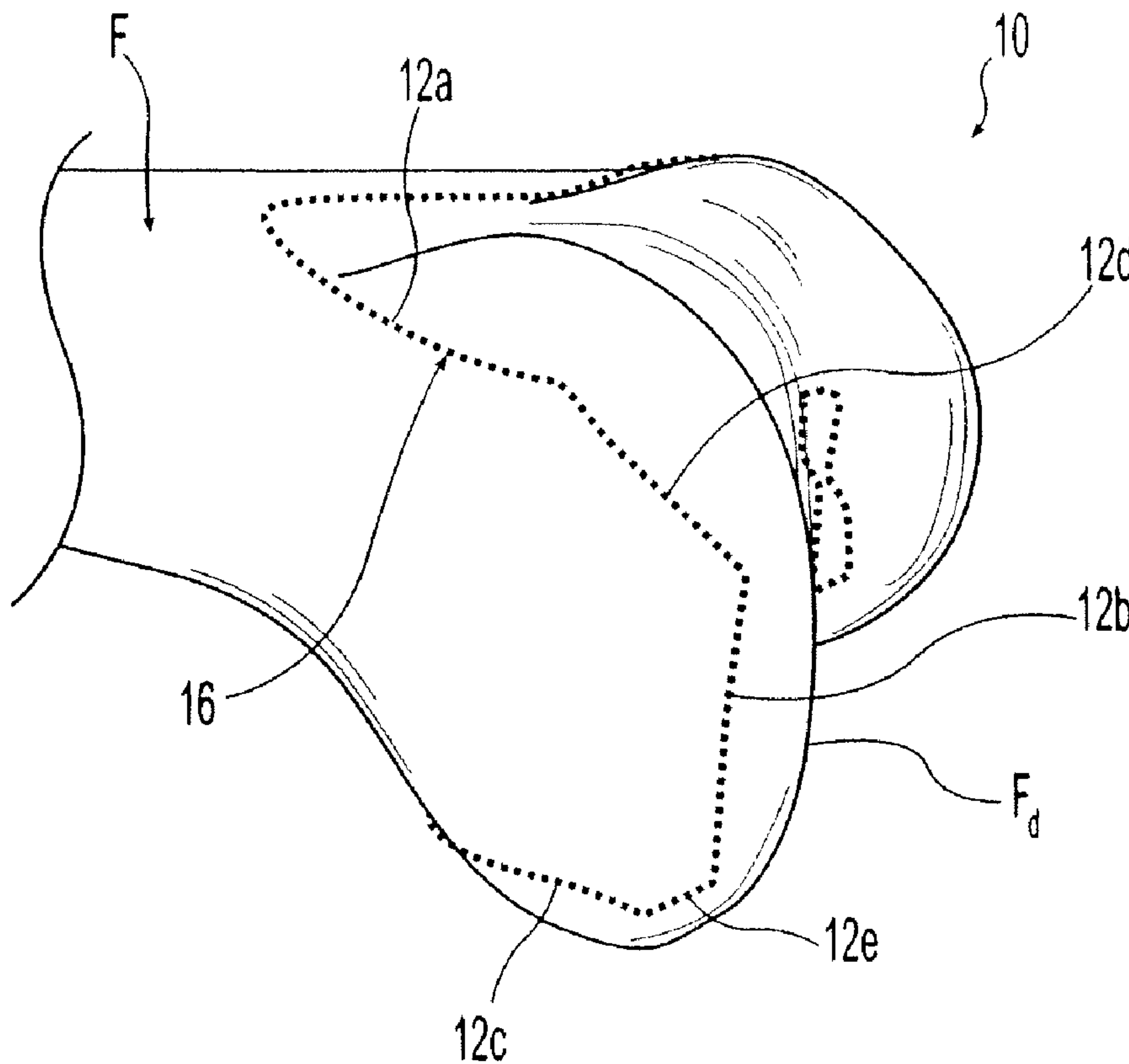

(86) Date de dépôt PCT/PCT Filing Date: 2007/03/14  
 (87) Date publication PCT/PCT Publication Date: 2007/09/27  
 (85) Entrée phase nationale/National Entry: 2008/08/28  
 (86) N° demande PCT/PCT Application No.: US 2007/063949  
 (87) N° publication PCT/PCT Publication No.: 2007/109467  
 (30) Priorité/Priority: 2006/03/17 (US60/783,630)

(51) Cl.Int./Int.Cl. *A61F 2/30* (2006.01),  
*A61B 5/103* (2006.01)  
 (71) Demandeurs/Applicants:  
 ZIMMER, INC., US;  
 MAHFOUZ, MOHAMED, US  
 (72) Inventeurs/Inventors:  
 EARL, BRIAN D., US;  
 MAHFOUZ, MOHAMED, US  
 (74) Agent: GOWLING LAFLEUR HENDERSON LLP

(54) Titre : METHODES POUR PREDETERMINER LE CONTOUR D'UNE SURFACE OSSEUSE RESEQUEE ET POUR ESTIMER L'AJUSTEMENT D'UNE PROTHESE SUR L'OS  
 (54) Title: METHODS OF PREDETERMINING THE CONTOUR OF A RESECTED BONE SURFACE AND ASSESSING THE FIT OF A PROSTHESIS ON THE BONE



(57) Abrégé/Abstract:  
 Methods for predetermining a contour (18) of a resected bone surface (12) and assessing a fit of a prosthesis (20) on the resected bone surface, for designing prostheses to fit discrete patient populations, and for designing customized prostheses.

(12) INTERNATIONAL APPLICATION PUBLISHED UNDER THE PATENT COOPERATION TREATY (PCT)

(19) World Intellectual Property Organization  
International Bureau(43) International Publication Date  
27 September 2007 (27.09.2007)

PCT

(10) International Publication Number  
**WO 2007/109467 A1**

## (51) International Patent Classification:

A61F 2/30 (2006.01) A61B 5/103 (2006.01)

## (21) International Application Number:

PCT/US2007/063949

(22) International Filing Date: 14 March 2007 (14.03.2007)

(25) Filing Language: English

(26) Publication Language: English

## (30) Priority Data:

60/783,630 17 March 2006 (17.03.2006) US

(71) Applicant (for all designated States except US): **ZIMMER TECHNOLOGY, INC.** [US/US]; P.o. Box 708, 345 East Main Street, Warsaw, IN 46580 (US).

## (72) Inventors; and

(75) Inventors/Applicants (for US only): **MAHFOUZ, Mohamed** [US/US]; 201 Longbow Road, Knoxville, TN 37922 (US). **EARL, Brian, D.** [US/US]; 1624 Arcadia Avenue, South Bend, IN 46639 (US).(74) Agent: **ALL AGENTS ASSOCIATED W/ CUST. #43963**; Zimmer Technonology - Baker & Daniels, 111 East Wayne Street, Suite 800, Fort Wayne, IN 46802 (US).

(81) Designated States (unless otherwise indicated, for every kind of national protection available): AE, AG, AL, AM, AT, AU, AZ, BA, BB, BG, BR, BW, BY, BZ, CA, CH, CN, CO, CR, CU, CZ, DE, DK, DM, DZ, EC, EE, EG, ES, FI, GB, GD, GE, GH, GM, GT, HN, HR, HU, ID, IL, IN, IS, JP, KE, KG, KM, KN, KP, KR, KZ, LA, LC, LK, LR, LS, LT, LU, LY, MA, MD, MG, MK, MN, MW, MX, MY, MZ, NA, NG, NI, NO, NZ, OM, PG, PH, PL, PT, RO, RS, RU, SC, SD, SE, SG, SK, SL, SM, SV, SY, TJ, TM, TN, TR, TT, TZ, UA, UG, US, UZ, VC, VN, ZA, ZM, ZW.

(84) Designated States (unless otherwise indicated, for every kind of regional protection available): ARIPO (BW, GH, GM, KE, LS, MW, MZ, NA, SD, SL, SZ, TZ, UG, ZM, ZW), Eurasian (AM, AZ, BY, KG, KZ, MD, RU, TJ, TM), European (AT, BE, BG, CH, CY, CZ, DE, DK, EE, ES, FI, FR, GB, GR, HU, IE, IS, IT, LT, LU, LV, MC, MT, NL, PL, PT, RO, SE, SI, SK, TR), OAPI (BF, BJ, CF, CG, CI, CM, GA, GN, GQ, GW, ML, MR, NE, SN, TD, TG).

## Published:

- with international search report
- before the expiration of the time limit for amending the claims and to be republished in the event of receipt of amendments

[Continued on next page]

(54) Title: METHODS OF PREDETERMINING THE CONTOUR OF A RESECTED BONE SURFACE AND ASSESSING THE FIT OF A PROSTHESIS ON THE BONE

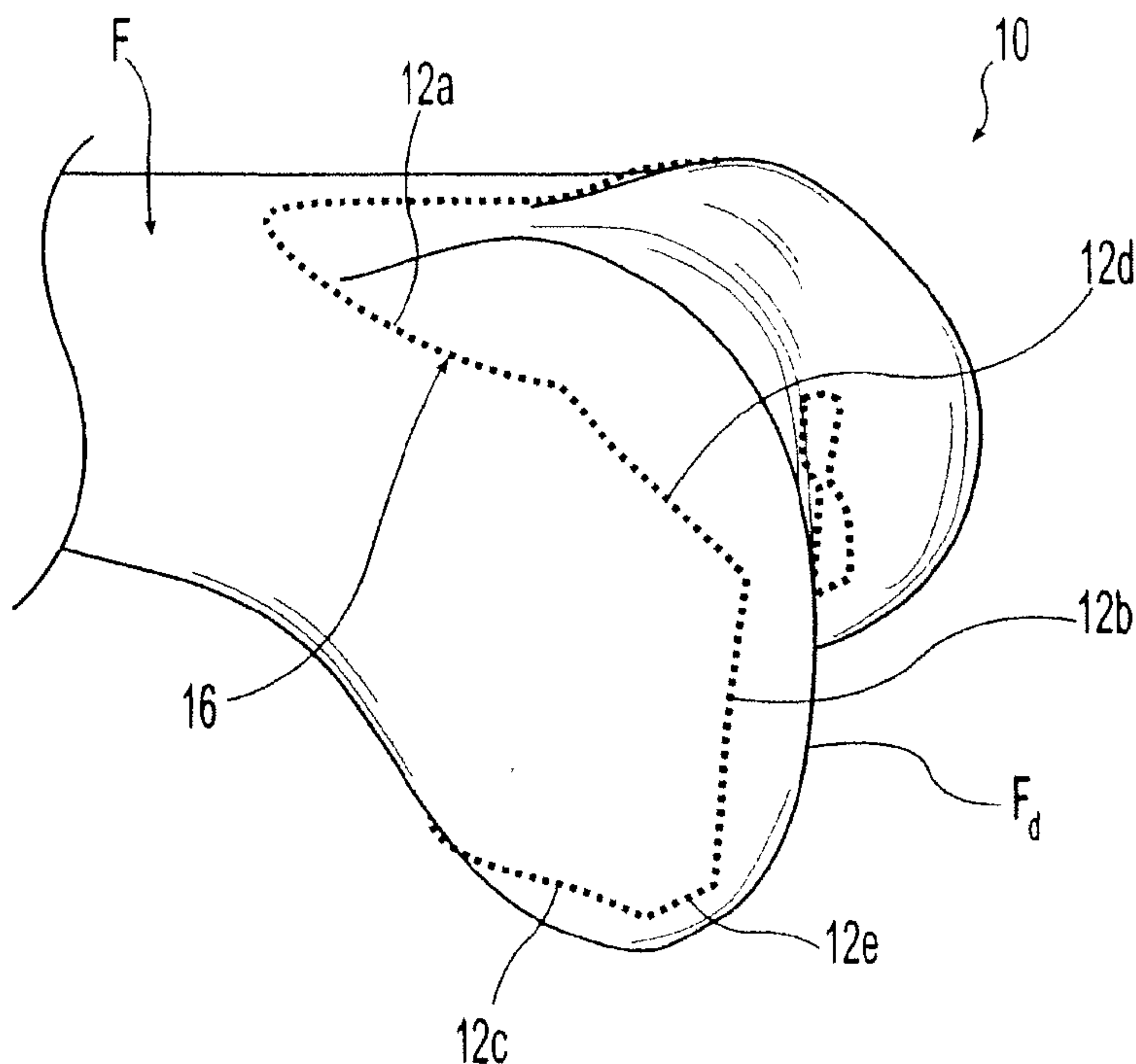

(57) Abstract: Methods for predetermining a contour (18) of a resected bone surface (12) and assessing a fit of a prosthesis (20) on the resected bone surface, for designing prostheses to fit discrete patient populations, and for designing customized prostheses.

WO 2007/109467 A1

**WO 2007/109467 A1**



---

*For two-letter codes and other abbreviations, refer to the "Guidance Notes on Codes and Abbreviations" appearing at the beginning of each regular issue of the PCT Gazette.*



## **METHODS OF PREDETERMINING THE CONTOUR OF A RESECTED BONE SURFACE AND ASSESSING THE FIT OF A PROSTHESIS ON THE BONE**

### CROSS REFERENCE TO RELATED APPLICATIONS

**[0001]** This application claims the benefit under Title 35, U.S.C. § 119(e) of U.S. Provisional Patent Application Serial No. 60/783,630, entitled METHODS OF PREDETERMINING THE CONTOUR OF A RESECTED BONE AND THE FIT OF AN IMPLANT ON THE BONE, filed March 17, 2006, the disclosure of which is hereby expressly incorporated herein by reference.

### BACKGROUND

**[0002]** The present disclosure relates to methods for determining an optimal fit of a prosthesis on a resected bone surface.

**[0003]** Orthopaedic procedures for the replacement of all, or a portion of, a patient's joint typically require resecting and reshaping of the bones of the joint to receive prosthetic components. For example, a typical total knee prosthesis has three main components: a femoral component for replacing at least a portion of the distal end of the femur, a tibial component for replacing at least a portion of the proximal end of the tibia, and a bearing insert for replacing at least a portion of the articulating tissue between the femur and the tibia. Procedures for implanting a total knee prosthesis typically involve preparing and reshaping both the distal end of the femur and the proximal end of the tibia prior to implanting the prosthetic components. The amount of bone removed may be partially determined by the size and type of prosthetic components to be implanted. The size of prosthetic components may be initially determined by measurements taken of the knee prior to and during surgery, and the final determination of size may be made after taking measurements and trialing a provisional prosthesis during the procedure.

## SUMMARY

**[0004]** The present disclosure provides methods for predetermining a contour of a resected bone surface and assessing a fit of a prosthesis on the resected bone surface. The present disclosure also provides methods for designing prostheses to fit discrete patient populations as well as methods for designing customized prostheses.

**[0005]** In one form thereof, the present disclosure provides a method of virtually assessing the fit of a prosthesis for placement on a resected bone surface, the method including the steps of creating a two-dimensional outline of the resected bone surface; creating a two-dimensional outline of a first prosthesis; and comparing the two-dimensional outline of the resected bone surface with the two-dimensional outline of the first prosthesis. In another form thereof, the present disclosure provides an apparatus for virtually assessing the fit of a prosthesis for placement on a resected bone surface, the apparatus including a first computer adapted to create a two-dimensional outline of the resected bone surface; a second computer for creating a two-dimensional outline of a first prosthesis; and a third computer for comparing the two-dimensional outline of the resected bone surface with the two-dimensional outline of the first prosthesis. In yet another form thereof, the present disclosure provides a method of designing a prosthesis to substantially fit a resected bone surface based on a population of bones, the method including the steps of creating a plurality of two-dimensional outlines corresponding to each resected bone surface for each bone of the population; and determining a contour of a bone engaging surface of a prosthesis using the plurality of two-dimensional outlines, wherein the contour substantially matches the plurality of two-dimensional outlines of the resected bone surfaces. In still another form thereof, the present disclosure provides an apparatus for designing a prosthesis to substantially fit a resected bone surface based on a population of bones, the apparatus including a first computer for creating a plurality of two-dimensional outlines corresponding to each resected bone surface for each bone of the population; and a second computer for determining a contour of a bone engaging surface of a prosthesis which substantially matches the plurality of two-dimensional outlines of the resected bone surfaces. In one form thereof, the present disclosure provides a method of creating a prosthesis for placement on a resected bone surface, the method including the steps of creating a two-dimensional outline of the resected bone surface; and determining a contour of a bone engaging surface of a



prosthesis using the two-dimensional outline of the resected bone surface. In another form thereof, the present disclosure provides an apparatus for creating a prosthesis for placement on a resected bone surface, the apparatus including a first computer for creating a two-dimensional outline of the resected bone surface; and a second computer for determining a contour of a bone engaging surface of a prosthesis using the two-dimensional outline of the resected bone surface.

#### BRIEF DESCRIPTION OF THE DRAWINGS

[0006] The above mentioned and other features of the disclosure, and the manner of attaining them, will become more apparent and will be better understood by reference to the following description of embodiments of the disclosure taken in conjunction with the accompanying drawings, wherein:

[0007] FIG. 1 is a perspective view of a digital model of the distal end of a femur including a virtual resection according to an exemplary method of the present disclosure;

[0008] FIG. 2 is a perspective view of the digital model of FIG. 1, further illustrating the vertices of the virtual resection;

[0009] FIG. 3 is a top view of the two-dimensional outline of the femoral resection of FIG. 1;

[0010] FIG. 4 a perspective view of an exemplary distal femoral prosthesis which may be used in an exemplary method of the present disclosure;

[0011] FIG. 5 is a perspective view of the prosthesis of FIG. 4, further illustrating the step of virtually unfolding the prosthesis;

[0012] FIG. 6 is a top view of the two-dimensional outline of the prosthesis of FIG. 4 after the unfolding step of FIG. 5;

[0013] FIG. 7 is an illustration of another step of the method of the present disclosure wherein outlines of several exemplary prostheses are compared with outlines of several virtually resected exemplary femurs; and

[0014] FIG. 8 is another illustration of the step shown in FIG. 7.

**[0015]** Corresponding reference characters indicate corresponding parts throughout the several views. Although the drawings represent embodiments of the present disclosure, the drawings are not necessarily to scale and certain features may be exaggerated in order to better illustrate and explain the present disclosure. Although the exemplifications set out herein illustrate embodiments of the disclosure, the embodiments disclosed below are not intended to be exhaustive or to be construed as limiting the scope of the invention to the precise forms disclosed.

### DETAILED DESCRIPTION

**[0016]** The present disclosure may include references to the following terms: anterior (at or near the front of the body, as opposed to the back of the body); posterior (at or near the back of the body, as opposed to the front of the body); lateral (at or near the side of the body, farther from the midsagittal plane, as opposed to medial); medial (at or near the middle of the body, at or near the midsagittal plane, as opposed to lateral); proximal (toward the beginning, at or near the head of the body, as opposed to distal); and distal (further from the beginning, at or near the foot of the body, as opposed to proximal).

**[0017]** Referring to FIGS. 1-8, an exemplary method of the present disclosure may be used to determine how a femoral prosthesis will fit on the distal end of a femur, i.e., to assess whether a prosthesis is of the right size and shape for the distal end of the femur and whether the prosthesis suitably conforms thereto. The method generally includes the steps of obtaining a three-dimensional (3-D) model of a bone based on an acquired image of the bone, virtually resecting the 3-D model of the bone, i.e., creating or simulating a resection of the bone within a computer or other intelligent processing device, preparing a bone profile of the virtual resection, creating a two-dimensional (2-D) outline or footprint of the resection from the bone profile, preparing an prosthesis profile, creating a 2-D outline or footprint from the prosthesis profile, and comparing the 2-D outlines of the bone profile and the prosthesis profile to assess or determine the fit of the prosthesis with the bone.

**[0018]** More particularly, referring to FIG. 1, 3-D digital model 10 of an exemplary femur F is illustrated. Digital model 10 may be obtained by obtaining a computed tomography ("CT") scan of a femur to produce a 3-D image of the femur and converting the 3-D image to



digital model 10. The conversion of the 3-D CT scan image to 3-D digital model 10 may be performed using any suitable modeling software including, for example, Amira<sup>®</sup>, available from Mercury Computer Systems, Inc., of Chelmsford, Massachusetts. Digital model 10 may include femur F having distal end F<sub>d</sub>.

**[0019]** Referring still to FIG. 1, using suitable software, such as MATLAB<sup>®</sup>, available from The MathWorks, of Natick, Massachusetts, and Unigraphics<sup>®</sup>, available from UGS Corp., of Plano, Texas, a virtual resection of distal end F<sub>d</sub> of model femur F is performed. Similar to the resection performed in actual knee arthroplasty procedures, the virtual resection involves defining femoral cut planes 12a-12e on distal end F<sub>d</sub> of model femur F. Femoral cut planes 12a-12e are calculated using an algorithm of the software. The algorithm calculates femoral cut planes 12a-12e based on a proposed, exemplary femoral prosthesis and the known surgical technique specified for the proposed femoral prosthesis. More particularly, distal end F<sub>d</sub> of model femur F may be preliminarily measured based on the known surgical technique and using the software described above. The resulting measurements are used to preliminarily select a femoral prosthesis size and type. Resection of distal end F<sub>d</sub> of model femur F is determined by the selected femoral prosthesis and involves resecting distal end F<sub>d</sub> of femur F to complement and receive the prosthesis. For example, as shown in FIG. 4, model femoral prosthesis 20 may be preliminarily selected. Femoral prosthesis 20 is a cruciate-retaining femoral prosthetic component having bone engaging surface 22. Bone engaging surface 22 includes a plurality of intersecting planar surfaces, including anterior surface 22a, distal surface 22b, posterior surface 22c, anterior chamfer surface 22d, and posterior chamfer surface 22e. Accordingly, as shown in FIG. 1, the virtual resection of distal end F<sub>d</sub> of model femur F includes defining a plurality of intersecting cut planes 12a-12e including anterior cut plane 12a, distal cut plane 12b, posterior cut plane 12c, anterior chamfer cut plane 12d, and posterior chamfer cut plane 12e, which correspond to the plurality of intersecting planar surfaces 22a-22e of model prosthesis 20 (FIG. 4). As illustrated in FIGS. 2 and 3, cut planes 12a-12e intersect one another at femoral cut plane vertices 14a-14d. More particularly, anterior cut plane 12a intersects anterior chamfer cut plane 12d at vertex 14a. Anterior chamfer cut plane 12d intersects distal cut plane 12b at vertex 14b. Distal cut plane 12b intersects posterior chamfer cut plane 12e at vertex 14c. Posterior chamfer cut plane 12e intersects posterior cut plane 12c at vertex 14d.



**[0020]** Referring still to FIGS. 1 and 2, femoral profile 16, shown as a dotted line, of the virtually resected model femur F is prepared by outlining cut planes 12a-12e extending between cut plane vertices 14a-14d. Two-dimensional outline or footprint 18 of the resected surface of model femur F is then obtained, as shown in FIG. 3, by unfolding or bending profile 16 at cut plane vertices 14a-14d until cut planes 12a-12e are aligned in a single plane. The suitable software mentioned above may be used to manipulate profile 16 to create two-dimensional outline 18.

**[0021]** Referring now to FIGS. 4-6, two-dimensional outline or footprint 26 of proposed prosthesis 20 may be made using a process similar to that described above for outline or footprint 18 of femoral profile 16. More particularly, 3-D digital model 20 of a femoral prosthesis may be obtained using any known method and any suitable software, including those described above. As discussed above, model prosthesis 20 includes bone engaging surface 22, which includes anterior planar surface 22a, distal planar surface 22b, posterior planar surface 22c, anterior chamfer planar surface 22d, and posterior chamfer planar surface 22e. Planar surfaces 22a-22e intersect one another at prosthesis vertices 24a-24d. More particularly, anterior planar surface 22a intersects anterior chamfer surface 22d at vertex 24a. Anterior chamfer surface 22d intersects distal planar surface 22b at vertex 24b. Distal planar surface 22b intersects posterior chamfer surface 22e at vertex 24c, and posterior chamfer surface 22e intersects posterior surface 22c at vertex 24d.

**[0022]** Referring to FIG. 4, prosthesis profile 25 of model prosthesis 20 is prepared by outlining the perimeter of intersecting planar surfaces 22a-22e between prosthesis vertices 24a-24d. Prosthesis profile 25 is represented by the heavy dashed line extending about the perimeter of model prosthesis 20. Turning to FIGS. 5 and 6, two-dimensional outline or footprint 26 of prosthesis profile 25 is created by using the suitable software to unfold or bend profile 25 at vertices 24a-24d until planar surfaces 22a-22e are aligned within a single plane.

**[0023]** Prosthesis outline 26 may be visually compared with femur outline 18 to determine and assess whether model prosthesis 20 is a suitable fit for model femur 10. Prosthesis outline 26 may be compared with femur outline 18 by superimposing one atop the other and observing the overlapping shapes and the differences therebetween. Furthermore,

using the suitable software mentioned above, quantitative analysis may be made of outlines 26 and 18. For instance, measurements of outlines 26 and 18 may be taken and the suitable software can calculate deviations between the measurements. For example, width measurements of outlines 26 and 18 at the intersections of each planar surface may be taken and/or at midpoints of each planar surface between such intersections with other planar surfaces. Any deviations between outlines 26 and 18 may then be used to calculate proposed changes in prosthesis 20 to thereby reshape prosthesis 20 to minimize the deviations. Alternatively, any deviations between outlines 26 and 18 may prompt a user to select a different prosthesis 20 and perform the same analysis to assess the fit of the second prosthesis 20 on model femur 10.

**[0024]** The method described above has several useful, practical applications. For example, the method described above may be used to develop new and improved existing prosthesis designs. It is contemplated that this method may be used to survey a large population of subjects to develop statistics and identify trends in bone shapes, and to adapt prosthesis sizes and shapes accordingly. More specifically, two-dimensional footprints of virtually resected bones of a large population of patients may be obtained and compared to two-dimensional footprints of numerous available prostheses.

**[0025]** FIGS. 7 and 8 illustrate an exemplary application of the methods of the present disclosure. FIG. 7 illustrates femur footprints or outlines 18a-18d, shown as dotted lines, taken from a virtually resected model of a femur of four different subjects compared with footprints or outlines 26a-26c, shown in solid lines, taken from three different models of available prostheses. FIG. 8 schematically illustrates the same footprints 18a-18d, 26a-26c. The comparison shown in FIGS. 7 and 8 demonstrates that the prosthesis yielding footprint 26a is larger in width W (FIG. 6) than the virtually resected bones yielding footprints 18b-18d. In an exemplary embodiment, outlines 18a-18d may be used to design or create a prosthesis which substantially matches at least some of outlines 18a-18d. For example, a prosthesis may be created or designed which is a best fit approximation to a plurality of outlines 18 which may be based on a specific patient population, such as the female population.

**[0026]** In an exemplary embodiment, a method of the present disclosure may be performed on the femurs of a large population of women to obtain medial/lateral and



anterior/posterior dimensions of the femurs and calculate ratios between the medial/lateral and anterior/posterior dimensions. These dimensions and calculations may be used in designing femoral components for use on female anatomy. In another exemplary embodiment, a method of the present disclosure may also be used to obtain medial/lateral and anterior/posterior dimensions of existing femoral components and calculate ratios between the medial/lateral and anterior/posterior dimensions of the femoral components. The dimensions and calculated ratios may then be used to compare existing femoral components to the dimensions and calculated ratios of the femurs of women to identify potential areas of the femoral component where fit can be optimized. Such a comparison is fully described in U.S. Patent Application Serial No. 11/611,021, entitled DISTAL FEMORAL KNEE PROSTHESES, assigned to the assignee of the present application, the disclosure of which is hereby expressly incorporated herein by reference. The same type of process may be performed for other populations, such as a population of males, various ethnic populations, populations based on age, stature-based populations, and/or populations based on disease progression or disease status.

**[0027]** In addition, the method described above may be used in guiding the design and manufacture of custom prostheses. For instance, a patient's femur may be modeled, virtually resected and footprinted as described above. The footprint could then be used as the footprint for forming a prosthesis. Although the method described above is exemplified with reference to the distal end of the femur and femoral prostheses, the methods of the present invention may be applied to any bone and any prosthesis.

**[0028]** While this invention has been described as having exemplary designs, the present disclosure may be further modified within the spirit and scope of this disclosure. This application is therefore intended to cover any variations, uses, or adaptations of the disclosure using its general principles. Further, this application is intended to cover such departures from the present disclosure as come within known or customary practice in the art to which this disclosure pertains.



**WHAT IS CLAIMED IS:**

1. A method of virtually assessing the fit of a prosthesis for placement on a resected bone surface (12), the method characterized by the steps of:  
creating a two-dimensional outline (18) of the resected bone surface;  
creating a two-dimensional outline (26) of a first prosthesis (20); and  
comparing the two-dimensional outline of the resected bone surface with the two-dimensional outline of the first prosthesis.
2. The method of Claim 1, further characterized by, if said comparing step results in an acceptable match of the outlines, the step of selecting the first prosthesis for physical placement on the resected bone surface.
3. The method of Claim 2, further characterized by, if said comparing step results in an unacceptable match of the outlines, the steps of creating a two-dimensional outline of a second prosthesis and comparing the two-dimensional outline of the resected bone surface with the two-dimensional outline of the second prosthesis.
4. The method of Claim 3, further characterized by, if said second comparing step results in an acceptable match of the outline of the resected bone surface and the outline of the second prosthesis, the step of selecting the second prosthesis for physical placement on the resected bone surface.
5. The method of any of the preceding claims, wherein said first creating step is characterized by the steps of:  
obtaining a three-dimensional contour (10) of the resected bone surface;  
identifying a vertex (14) between a first planar surface (12) of the resected bone surface and a second planar surface (12) of the resected bone surface;  
manipulating the first planar surface to be coplanar with the second planar surface; and  
outlining a perimeter (16) of the first planar surface and the second planar surface to define the two-dimensional outline of the resected bone surface.

6. The method of Claim 1, wherein said second creating step is characterized by the steps of:

obtaining a three-dimensional contour (20) of the first prosthesis;  
identifying a vertex (24) between a first planar surface (22) of the first prosthesis and a second planar surface (22) of the first prosthesis;  
manipulating the first planar surface to be coplanar with the second planar surface; and  
outlining a perimeter (25) of the first planar surface and the second planar surface to define the two-dimensional outline of the first prosthesis.

7. The method of Claim 1, wherein said comparing step is characterized by superimposing the two-dimensional outline of the resected bone surface on the two-dimensional outline of the first prosthesis.

8. An apparatus for virtually assessing the fit of a prosthesis for placement on a resected bone surface (12), the apparatus characterized by:

a first computer adapted to create a two-dimensional outline (18) of the resected bone surface;

a second computer for creating a two-dimensional outline (26) of a first prosthesis (20); and

a third computer for comparing the two-dimensional outline of the resected bone surface with the two-dimensional outline of the first prosthesis.

9. The apparatus of Claim 8, wherein said first computer is characterized by:  
a processor for identifying a vertex (14) between a first planar surface (12) of the resected bone surface and a second planar surface (12) of the resected bone surface based on a three-dimensional contour (10) of the resected bone surface;

wherein said first computer is adapted to manipulate the first planar surface to be coplanar with the second planar surface and to outline a perimeter (16) of

the first planar surface and the second planar surface to define the two-dimensional outline of the resected bone surface.

10. The apparatus of Claims 8 or 9, wherein said second computer is characterized by:

a processor for identifying a vertex (24) between a first planar surface (22) of the first prosthesis and a second planar surface (22) of the first prosthesis based on a three-dimensional contour (20) of the first prosthesis;

wherein said second computer is adapted to manipulate the first planar surface to be coplanar with the second planar surface and to outline a perimeter (25) of the first planar surface and the second planar surface to define the two-dimensional outline of the first prosthesis.

11. A method of designing a prosthesis to substantially fit a resected bone surface (12) based on a population of bones, the method characterized by the steps of:

creating a plurality of two-dimensional outlines (18) corresponding to each resected bone surface for each bone of the population; and

determining a contour (25) of a bone engaging surface (22) of a prosthesis (20) using the plurality of two-dimensional outlines, wherein the contour substantially matches the plurality of two-dimensional outlines of the resected bone surfaces.

12. The method of Claim 11, wherein said using step is characterized by the step of determining the contour of the bone engaging surface of the prosthesis using a best fit approximation of the plurality of two-dimensional outlines of the resected bone surfaces.

13. The method of Claims 11 or 12, wherein said creating step is characterized by the steps of:

obtaining a three-dimensional contour (10) of each resected bone surface; identifying a vertex (14) between a first planar surface (12) of each resected bone surface and a second planar surface (12) of each resected bone surface;



manipulating the first planar surface to be coplanar with the second planar surface; and

outlining a perimeter (16) of the first planar surface and the second planar surface to define the two-dimensional outline for each resected bone surface.

14. An apparatus for designing a prosthesis to substantially fit a resected bone surface (12) based on a population of bones, the apparatus characterized by:

a first computer for creating a plurality of two-dimensional outlines (18) corresponding to each resected bone surface for each bone of the population; and

a second computer for determining a contour (25) of a bone engaging surface (22) of a prosthesis (20) which substantially matches the plurality of two-dimensional outlines of the resected bone surfaces.

15. The apparatus of Claim 14, wherein said first computer is characterized by:

a processor for identifying a vertex (14) between a first planar surface (12) of the resected bone surface and a second planar surface (12) of the resected bone surface based on a three-dimensional contour (10) of the resected bone surface;

wherein said first computer is adapted to manipulate the first planar surface to be coplanar with the second planar surface and to outline a perimeter (16) of the first planar surface and the second planar surface to define the two-dimensional outline for each resected bone surface.

16. A method of creating a prosthesis for placement on a resected bone surface (12), the method characterized by the steps of:

creating a two-dimensional outline (18) of the resected bone surface; and  
determining a contour (25) of a bone engaging surface (22) of a prosthesis (20) using the two-dimensional outline of the resected bone surface.

17. The method of Claim 16, wherein said creating step is characterized by the steps of:

obtaining a three-dimensional contour (10) of the resected bone surface;  
identifying a vertex (14) between a first planar surface (12) of the resected bone surface and a second planar surface (12) of the resected bone surface;  
manipulating the first planar surface to be coplanar with the second planar surface; and  
outlining a perimeter (16) of the first planar surface and the second planar surface to define the two-dimensional outline of the resected bone surface.

18. An apparatus for creating a prosthesis for placement on a resected bone surface (12), the apparatus characterized by:  
a first computer for creating a two-dimensional outline (18) of the resected bone surface; and  
a second computer for determining a contour (25) of a bone engaging surface (22) of a prosthesis (20) using the two-dimensional outline of the resected bone surface.

19. The apparatus of Claim 18, wherein said first computer is characterized by:  
a processor for identifying a vertex (14) between a first planar surface (12) of the resected bone surface and a second planar surface (12) of the resected bone surface based on a three-dimensional contour (10) of the resected bone surface;  
wherein said first computer is adapted to manipulate the first planar surface to be coplanar with the second planar surface and to outline a perimeter (16) of the first planar surface and the second planar surface to define the two-dimensional outline of the resected bone surface.

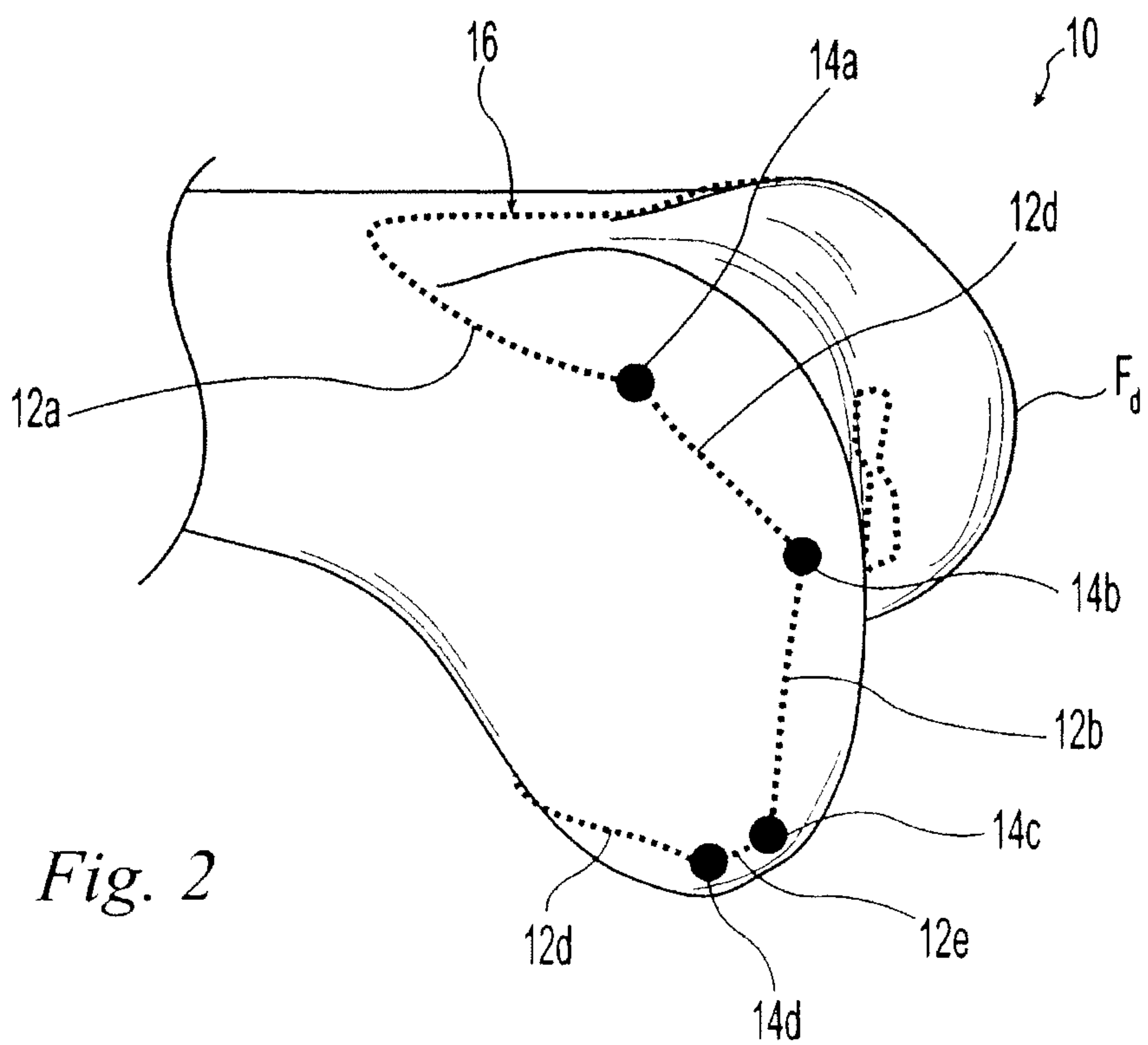
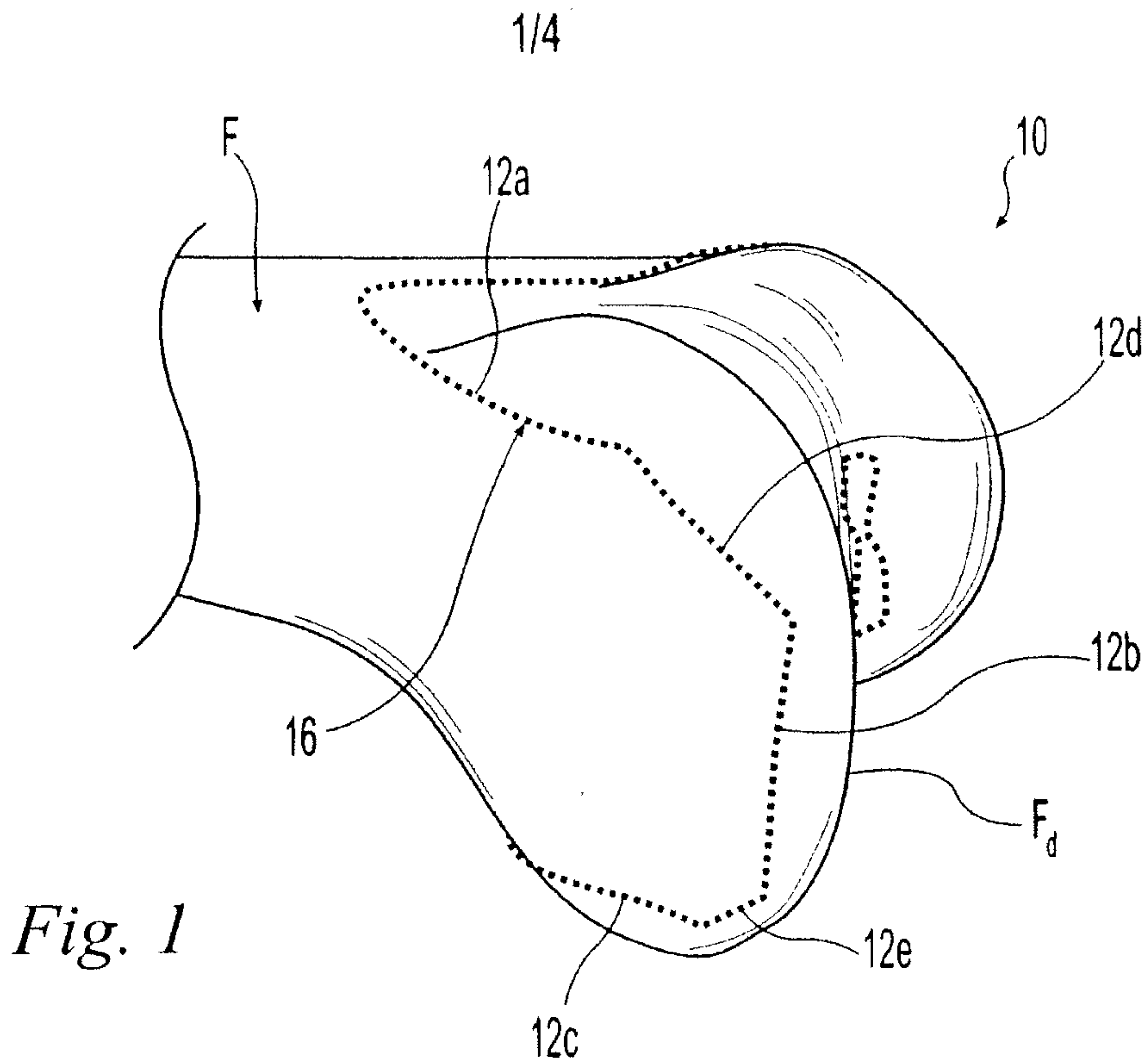



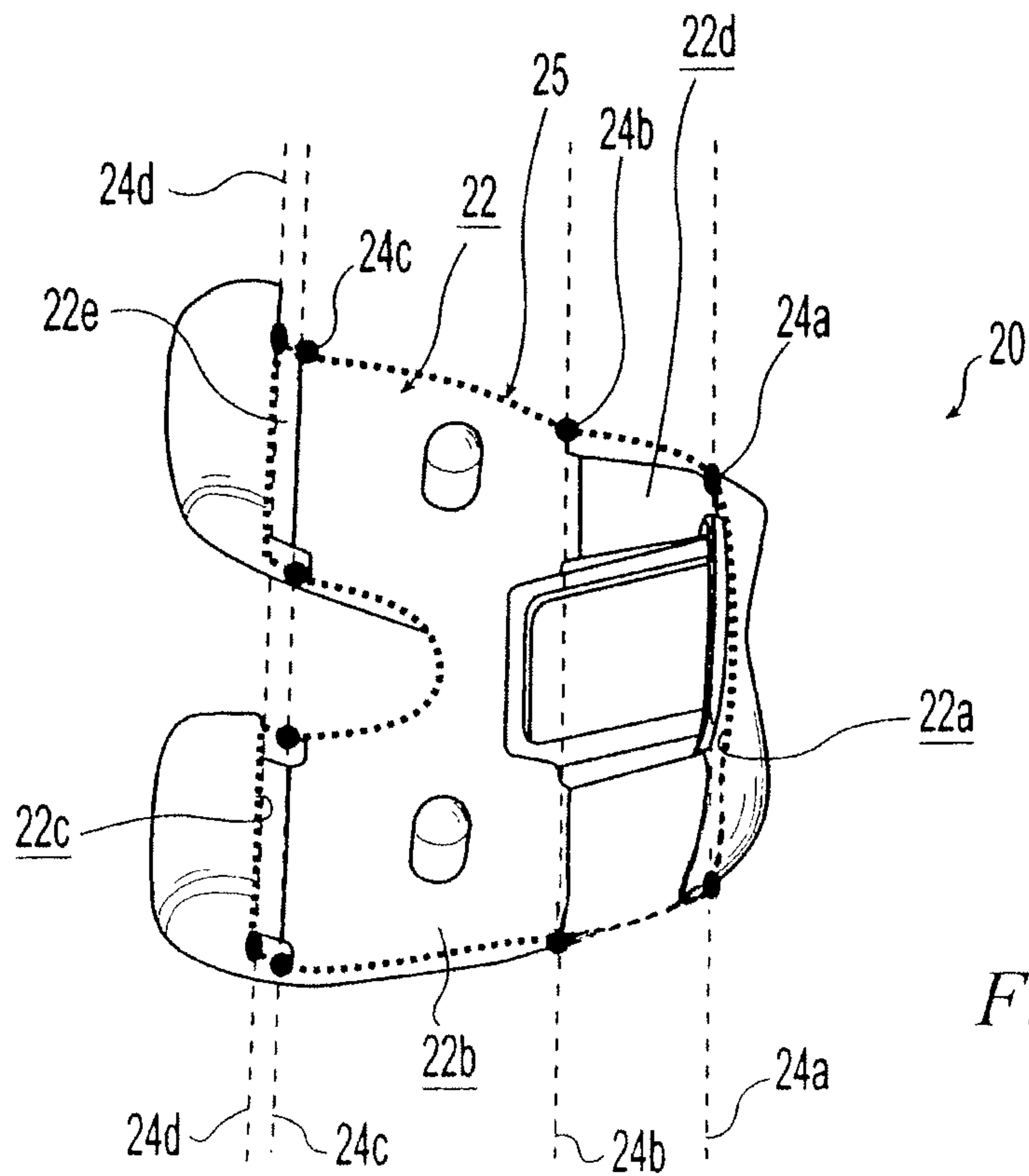
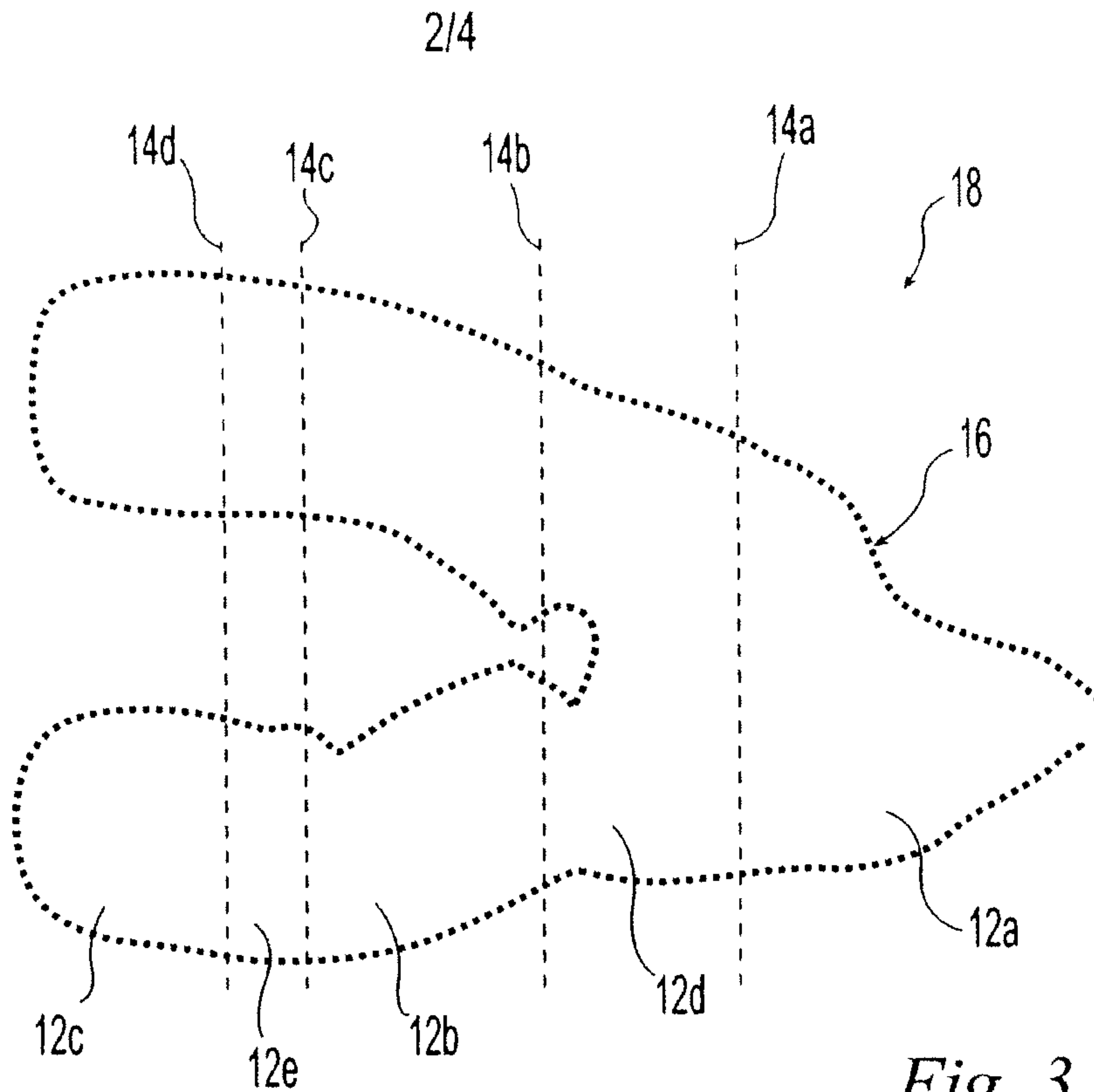

3/4

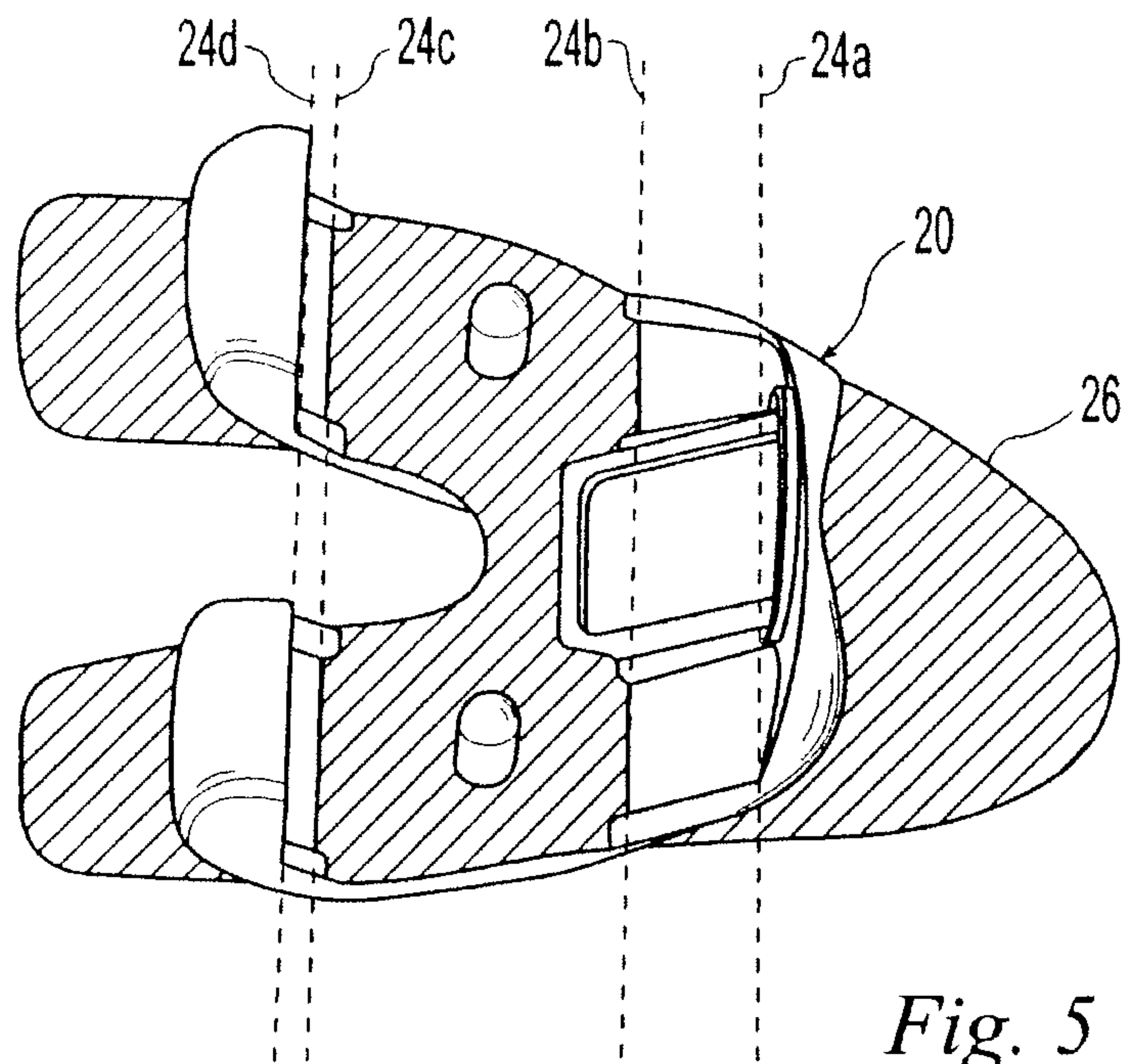

Fig. 5

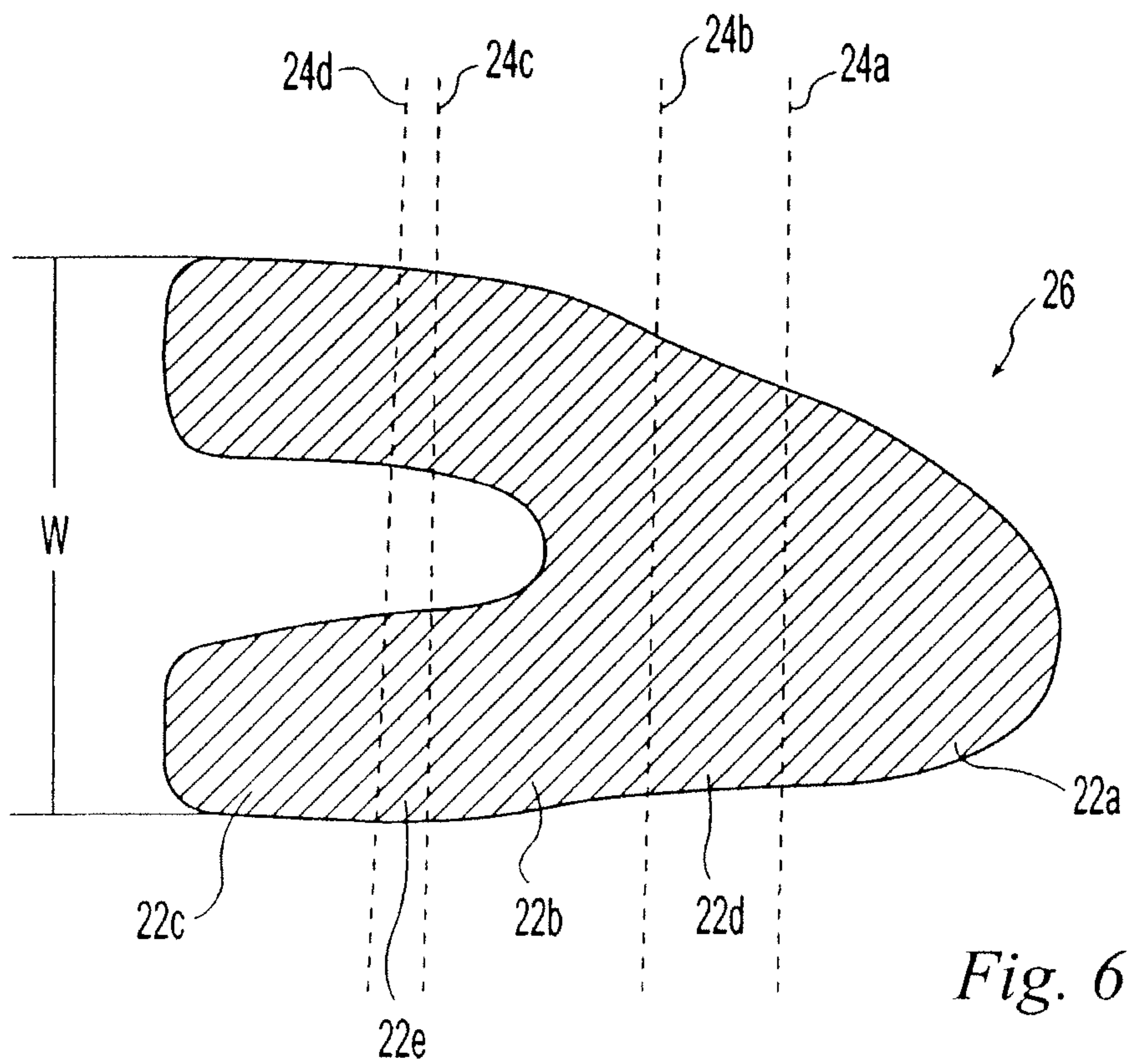
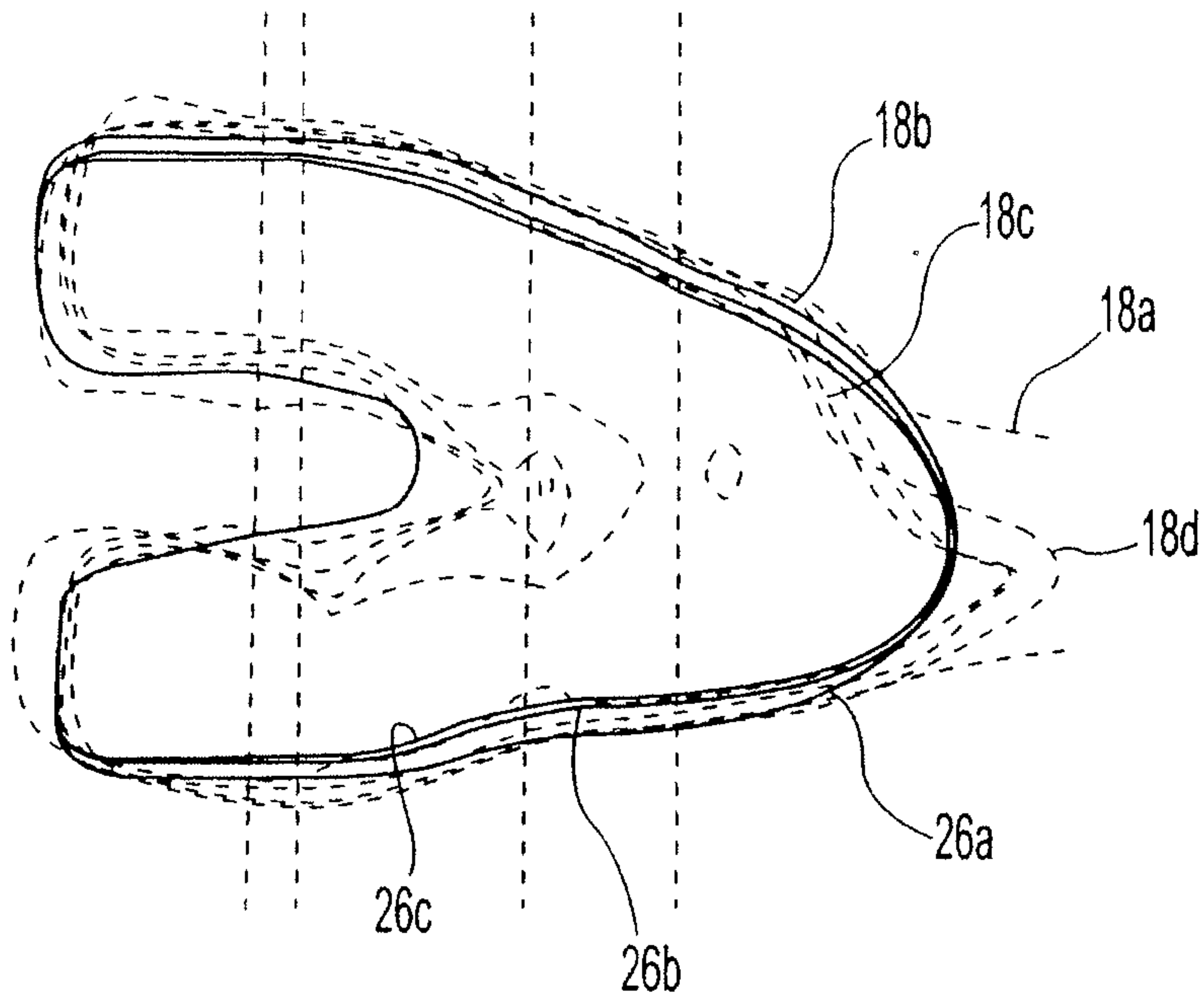
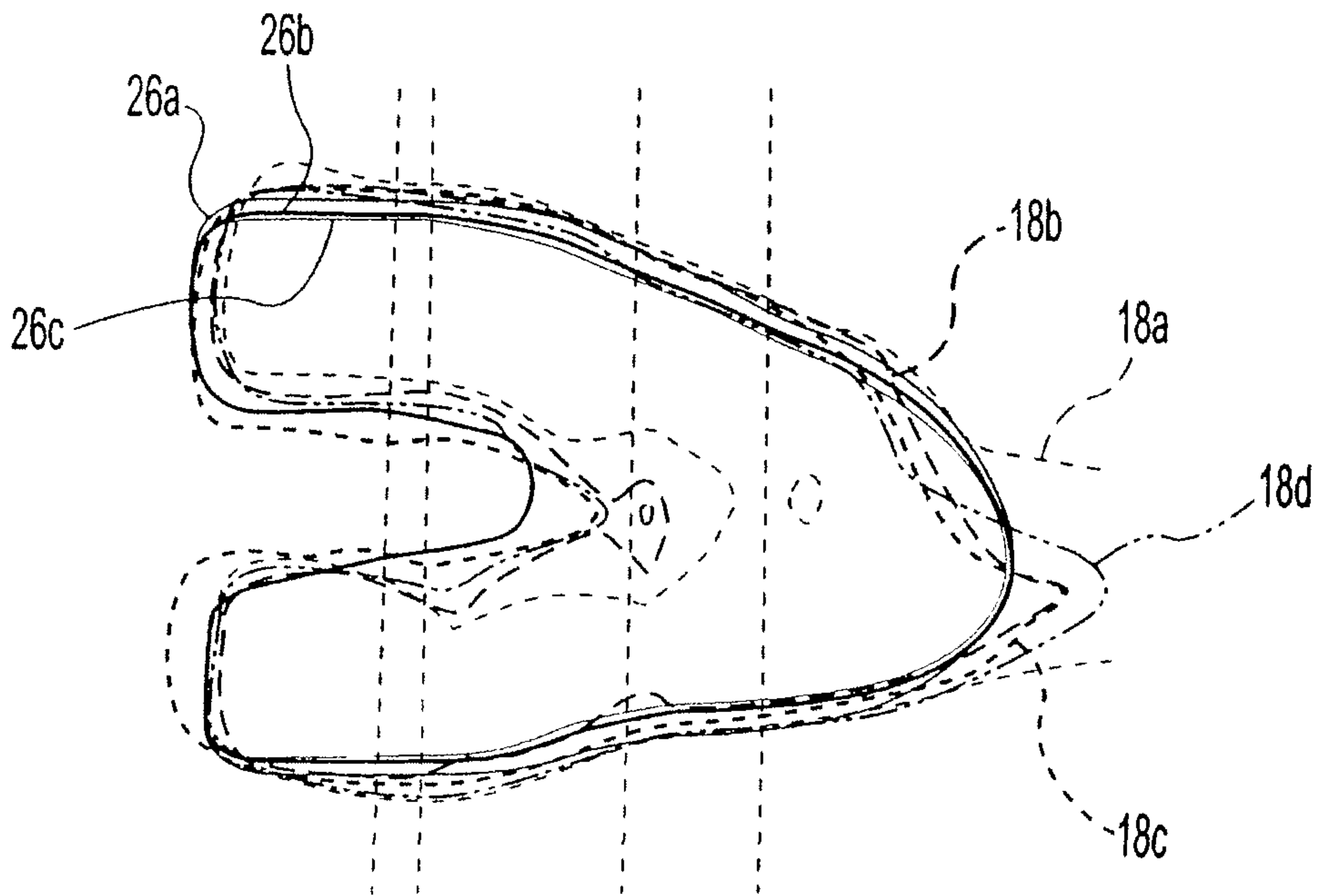

Fig. 6

4/4



*Fig. 7*



*Fig. 8*



