

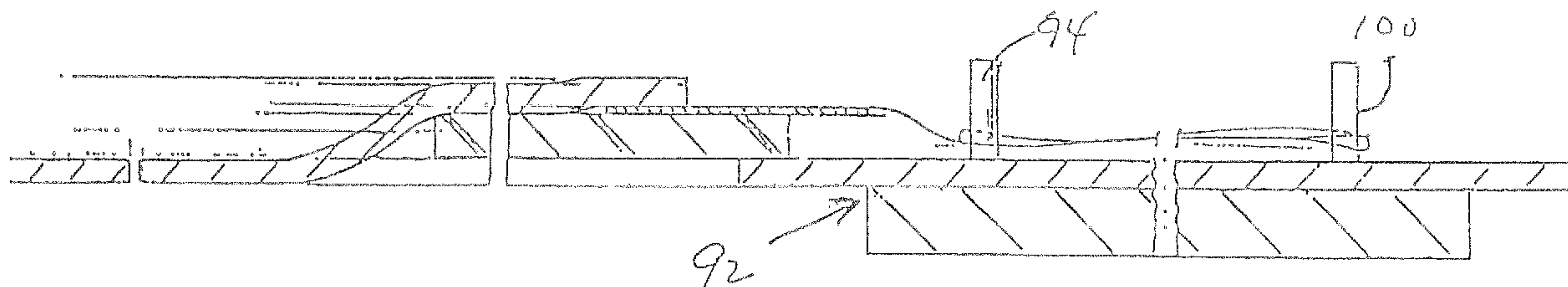

(22) Date de dépôt/Filing Date: 1991/11/04
 (41) Mise à la disp. pub./Open to Public Insp.: 1992/06/18
 (62) Demande originale/Original Application: 2 054 902
 (30) Priorités/Priorities: 1990/12/17 (07/629,114) US;
 1991/08/16 (07/746,492) US

(51) Cl.Int.⁷/Int.Cl.⁷ A61B 17/06, B65D 85/24
 (71) Demandeur/Applicant:
 UNITED STATES SURGICAL CORPORATION, US
 (72) Inventeurs/Inventors:
 HOLZWARTH, HENRY A. (DECEASED), US;
 SCANLON, CHRISTOPHER M., US
 (74) Agent: MCFADDEN, FINCHAM

(54) Titre : EMBALLAGE DE SUTURES MULTIPLES
 (54) Title: PACKAGE FOR MULTIPLE SUTURES



(57) **Abrégé/Abstract:**

A suture package is disclosed which is formed of a first row of a plurality of panel members of substantially similar shape foldably connected to each other and arranged to fold upon each other to form at least three individual suture compartments between pairs of adjacent panel members, each compartment being arranged to accommodate at least one flexible suture therein, and a second row of a plurality of panel members connected to one panel of a first row of panel members, a second row of panel members foldably connected to each other and foldable independent of a first row, a second row of panel members further being foldable in a manner to substantially enclose a first row of panel members folded upon each other.

ABSTRACT

A suture package is disclosed which is formed of a first row of a plurality of panel members of substantially similar shape foldably connected to each other and arranged to fold upon each other to form at least three individual suture compartments between pairs of adjacent panel members, each compartment being arranged to accommodate at least one flexible suture therein, and a second row of a plurality of panel members connected to one panel of a first row of panel members, a second row of panel members foldably connected to each other and foldable independent of a first row, a second row of panel members further being foldable in a manner to substantially enclose a first row of panel members folded upon each other.

-1-

PACKAGE FOR MULTIPLE SUTURES

This application is a divisional of co-pending Canadian Application Serial Number 2,054, 902, filed November 4, 1991.

5 This invention relates to packages for multiple sutures whereby a plurality of panels define one individual compartment for the needles and a plurality of panels separate the flexible suture portions.

10 2. Description of the Prior Art

 Packaging of surgical needles and sutures requires that the needles be secured properly to prevent displacement, as well as being simply and quickly removable from their packages for use by the surgeon. Jarring or displacement of
15 such sharp needles will tend to dull their edges and reduce their effectiveness while increasing trauma to the patient during use.

 Also it is desirable to package the needle/suture combinations in a manner where they are sufficiently separated
20 for ready access to the user when they are needed. Moreover, the suture packages must be capable of receiving and holding sutures of various sizes while generally not affecting the quality, shape or strength of the suture in any way.

 In general, a most significant objective in suture
25 packaging is to store and maintain the relatively delicate ligatures in some form of spaced relation to each other so that access and removal of the suture may be readily

- 2 -

available without adversely affecting the ligature or the
needle as noted hereinabove. The present invention is
directed to a suture package wherein a plurality of sutures
may be stored in a single package while maintaining the
5 individuality of each suture with respect to the others.

SUMMARY OF THE INVENTION

A suture package which comprises a first row of a plurality of
panel members of substantially similar shape foldably
10 connected to each other and arranged to fold upon each other
to form at least three individual suture compartments between
pairs of adjacent panel members, each compartment being
arranged to accommodate at least one flexible suture therein;
and a second row of a plurality of panel members connected to
15 one panel member of the first row of panel members, the second
row of panel members foldably connected to each other and
foldable independent of the first row, the second row of panel
members further being foldable in a manner to substantially
enclose the first row of panel members folded upon each other.

20

Preferably, each panel member of the first row is generally
rectangular and is connected to the next adjacent panel member
on a longer side, and each panel member of the second row is
generally rectangular and is connected to the next adjacent
25 panel member on a longer side.

It is also desirable the panel members of the second row are
connected to each other by a double fold line each of which
defines edge panel members to encompass the first row of panel
30 members folded upon each other.

According to the above embodiments of the present invention,
the first row of panel members contains at least three panel
members, the second row of panel members contains at least two

- 3 -

panel members, the second row of panel members contains three panel members.

In a particularly preferred embodiment of the above the three
5 panel members of the second row of panel members includes a first centrally positioned panel member and two adjacent panel members foldably connected to the centrally positioned panel member.

10 Moreover, it is further preferred that the centrally positioned panel member of the second row of panel members is connected to one panel member of the first row of panel members along respective shorter sides thereof, the second row of panel members is folded along the shorter side of the
15 centrally positioned panel member, the adjacent panel members of the second row being respectively folded around the folded panel members of the first row to enclose the first row, and the adjacent panel members of the second row of panel members include means for retaining the second row of panel members in
20 a folded condition around the folded first row of panel members, the retaining means of the adjacent panel members comprises at least two slots in one of the adjacent panel members and at least two correspondingly dimensioned and configured cuts in a second of the adjacent panel members to
25 define tabs, the tabs being positioned and dimensioned for entry into the slots in the second panel member to retain the panel members of the second row in the folded condition.

It is also desirable in the above embodiment that the cuts in
30 the second panel member are arcuately configured to define respectively arcuate tabs, the first row of panel members contains at least six panel members.

Preferably, an end flap is connected to a shorter side of at
35 least one of the panel members of the first row such that when

- 4 -

the first row of panel members are in a fully folded condition to form the at least three suture compartments, the end flap folds over the shorter side to at least partially enclose the at least three suture compartments at first end portions
5 thereof.

Desirably, in the above embodiment, the end flap includes a generally tapered end portion connected along a fold line, the tapered end portion adapted to fold along the fold line to
10 assist in retaining the end flap in a folded condition.

Preferably, a second end flap is connected to a shorter side of at least one panel member of the first row such that when the first row of panel members are in a fully folded condition
15 to form the at least three compartments, the second end flap folds along the shorter side to at least partially enclose the at least three suture compartments at second end portions thereof.

20 Most preferably, the second end flap is connected to the shorter side of the at least one panel member of the first row by a double fold line, one of the panel members of the second row of panel members is provided with means for retaining at least two suture needles, and the means for retaining at least
25 two suture needles is a substantially planar insert member adapted for attachment to the one of said panel members of the second row of panel members.

According to the above embodiment, the substantially planar
30 insert member is of resilient material and has portions cut and lifted from the plane of the insert member, respective pluralities of the cut portions being dimensioned and positioned to engage respective portions of suture needles to retain the needles in respective fixed portions whereby the
35 needles are positioned in generally spaced relation and

- 5 -

individual flexible suture portions are respectively positioned in individual compartments formed by adjacent folded panel members of the first row.

5 Desirably, an end flap is connected to a shorter side of at least one panel member of the first row such that when the first row of panel members are in a fully folded condition to form the at least three suture compartments and the second row of panel members are folded to substantially enclose the first
10 row the end flap folds onto the one panel member of the second row having the retaining means to at least partially cover suture needles retained thereby, and the end flap is connected to the shorter side of the at least one panel member of the first row by a double fold line, and the first and second rows
15 of panel members are respectively connected to each other by an intermediate panel member, the intermediate panel member attached to the short sides of one panel member in each row.

In another embodiment of the present invention there is
20 provided a suture package, which comprises: a first row of at least four generally rectangular shaped panel members foldably connected to each other on longitudinal sides thereof and arranged to fold upon each other to form at least three individual suture compartments between pairs of adjacent panel
25 members, each the suture compartment dimensioned and shaped to accommodate an individual suture therein; a second row of at least three generally rectangular panel members foldably connected to each other on the longitudinal sides thereof; the first row of panel members being connected to the second row
30 of panel members on the short sides of one panel member in each row; and the second row of panel members foldable independent of the first row of panel members and arranged to receive and enclose the first row folded upon each other.

35 In another embodiment of the present invention, a suture

- 6 -

package for storing a plurality of individual suture portions, which comprises at least two rows of panel members, at least a first of the rows having at least four generally rectangular panel members foldably connected to each other and arranged to
5 fold upon each other to form at least three individual suture compartments between pairs of adjacent panel members, each said suture compartment dimensioned to accommodate an individual suture therein, at least a second of the rows having at least three generally rectangular panel members
10 foldable independent of the panel members of the at least first row and arranged to fold in a manner to substantially enclose the at least first row of panel members folded upon each other.

15 Desirably, each suture compartment is dimensioned to accommodate an individual suture portion in a coiled configuration.

It is further preferred of the above embodiment that the
20 suture compartment further comprises means associated with one of the panel members for retaining at least two suture needles attached to the individual suture portions.

In another embodiment of the present invention a suture
25 package for storing at least two flexible suture portions, which comprises at least two rows of panel members connected to each other, at least a first row of the at least two rows including a plurality of panel members arranged to fold upon each other to form at least three individual suture
30 compartments between pairs of adjacent panel members, each said compartment dimensioned to accommodate a single flexible suture therein, at least a second row of the at least two rows of panel members foldable independent from the remaining rows and arranged to fold in a manner to at least partially
35 encompass the remaining rows of panel members folded upon each other.

BRIEF DESCRIPTION OF THE DRAWINGS

Preferred embodiments of the invention are described herein below with reference to the drawings wherein:

5 Fig. 1A is a perspective view from the left side, of a package for multiple sutures constructed according to the present invention with all but one suture removed and illustrating removal of the last suture;

10 Fig. 1B is a plan view of a blank sheet constructed according to the invention defining a plurality of panel members foldably connected to each other;

15 Fig. 2A is an enlarged fragmentary view similar to Fig. 1B with a needle retaining planar insert member with five needles in position and illustrating the procedure to wind the first of the sutures about winding pins of a suture wrapping fixture;

20 Fig. 2B is an enlarged fragmentary view illustrating a portion of a needle retaining planar insert member constructed according to the invention, with one exemplary needle retained in position thereon;

Fig. 3 is a cross-sectional view taken along lines 3-3 of Fig. 2A illustrating the needle and the corresponding procedure to wind the suture about suture winding pins of a suture winding apparatus;

25 Fig. 4 is a view similar to Fig. 2A, with the first panel folded over the second compartment formed between the panels;

30 Fig. 5 is a view similar to Fig. 4 showing the third panel folded over the previously folded panels and illustrating the procedure for winding the third suture about winding pins into its respective compartment;

35 Fig. 6 is a view similar to Fig. 5 with the side panel folded over the previously folded panels and illustrating the procedure for winding the fourth suture about winding pines into its respective compartment;

- 8 -

Fig. 7 is a view similar to Fig. 6 with the fourth panel folded over the previously folded panels and illustrating the procedure for winding the fifth suture into its respective compartment;

5 Fig. 8 is a view similar to Fig.7 with the fifth and last panel folded over the previously folded panels into its final folded position;

10 Fig. 9 is a view illustrating the combined panels and sutures folded in position behind the face panel and illustrating the needle butt end cover tab in the last folded position;

Fig. 10 is a frontal view of the package for multiple sutures with the left hand panel folded behind the package;

15 Fig. 11 is a frontal view of the completed suture package of Fig. 10 with the right hand- and final- panel folded in position at the rear of the package;

20 Fig. 12 is a rear view of the folded suture package of Fig. 11 illustrating the locking tab feature which retains the package in its final folded position;

Fig. 13 is an enlarged cross-sectional view taken along lines 13-13 of Fig. 11 illustrating the individual panels which form the compartments for the sutures (not shown in this Fig.);

25 Fig. 14 is a plan view of an alternative embodiment of the blank sheet shown in Fig. 1B;

Fig. 15 is a plan view of another alternative embodiment of the blank sheet shown in Fig. 1B;

30 Fig. 16 is a frontal view of the embodiment of Fig. 15 in a partially folded condition with the end tab in the unfolded condition;

Fig. 17 is a frontal view of the embodiment of Fig. 15 in the fully folded condition;

35 Fig. 18 is a plan view another alternative embodiment of the blank sheet shown in Fig. 1B;

- 9 -

Fig. 19 is a plan view of still another alternative embodiment of the blank sheet shown in Fig. 1B; and

Fig. 20 is a plan view of still another alternative of the blank sheet shown in Fig. 1B.

5

DESCRIPTION OF THE PREFERRED EMBODIMENTS

Referring initially to Fig. 1A a five needle suture package 10 constructed according to the present invention is illustrated. The package is shown with all sutures except one removed for convenience of illustration. The last suture is shown partially removed from the package. Fig. 1B is a plan view of a blank sheet constructed according to the invention and defining a plurality of panel members foldably connected to each other to form individual suture compartments. When folded and provided with a needle holder insert panel as will be described, the suture package of Fig. 1B will appear as shown in Fig. 1A.

Referring once again to Fig. 1B, the blank sheet 12 is illustrated including panel 14 having cuts 16, 18, 20, 22 and 24 which are dimensioned, oriented and positioned to receive a resilient plastic needle retainer sheet 26 shown in Figs. 1A and 2B. The needle retainer sheet 26 is a planar sheet of plastic material having generally "V" shaped cuts 24 which define tabs which respectively alternate in direction and which are conveniently positioned to be lifted so as to receive and retain a plurality of curved suture needles in position as shown in Fig. 2B by exemplary needle 28. The plastic insert sheet 26 is rectangular in shape and cuts 22, 24 retain the upper corners. The upper mid-portion of the sheet and needles are exposed as shown in Figs. 1A and 2 A.

Referring once again to Fig. 1B, the blank sheet 12 includes separate and individual panels connected to each other as shown. An upper row of panels 30, 32, 34, 36, 38 and 40 are provided with individual respective cut out portions 42, 44, 46, 48 and 50 to reduce the girth of the package. In

35

- 10 -

addition, with the rear panel opened, the sutures may be viewed through the cut out portions as will be appreciated below. Panels 52 and 54 - being the rear panels of suture package 10 - do not include a cut out portion and therefore provide cover protection for the sutures.

Each panel 30, 32, 34, 36 and 38 is connected to the next adjacent panel by a single fold line, with front panel 14 being connected to rear panels 52 and 54 by double fold lines 56, 58, 60 and 62 to accommodate the thickness of the package and sutures. Intermediate encompassing panel 40 is also connected to the next adjacent panel 38 by double fold lines 51 and 53 to accommodate the girth of the first three panels - i.e. 48, 36 and 34 as will be seen in the description which follows.

Referring further to Fig. 1B, slotted cut outs 64, 66 are provided in panel 52 and correspondingly positioned arcuate cuts 68 and 70 are provided in panel 54. These cutouts and cuts are intended to close the package.

Referring once again to Fig. 1B, the upper row of panels includes a foldable end flap 76 connected to panel 30 by double fold line 78, 80 to accommodate the thickness of the package. This end flap includes a generally tapered extension 90 which functions to lock the package in the final folded condition as will be described. Each panel 30, 32, 34, 36, 38 and 40 includes "V" shaped cuts at the top and bottom side portions to form, with the next adjacent panel, diamond shaped openings 31, 33, 35, 37, 39, 41, 43, 45, 47, 49 to accommodate winding the suture as will be described.

Referring now to Fig. 3, a cross-sectional view of a suture wrapping fixture 92 is illustrated for packaging sutures in the package of the present invention. The wrapping fixture 92 includes upstanding pins, 94, 96, 98 and 100, which are dimensioned, configured and spaced for entry into the diamond shaped openings 3, 133, 345, 37, 39, 41, 43, 45, 47 and 49 formed by the adjacent "V" cuts on the sides of the

- 11 -

panels as shown in Figs. 2A and 3. The wrapping fixture is configured to receive the flat sheet of panels for wrapping sutures as set forth hereinbelow.

The flat sheet 12 of multiple panels as shown is preferably cut from a suitable package paper which is rigid yet flexible, and which is of sufficient thickness to separate and isolate the individual sutures from each other. It has been found that a paper panel material approximately .005 inch thickness is suitable and desirable. The flat sheet is preferably formed from a spun bonded polyolefin, free of any impurities which would adversely affect the sutures. A preferred material is 5 point to 10 point Tyvek brand spun bonded polyolefin sheet marketed by DuPont DeNemours, Wilmington, Delaware. Tyvek brand sheet has lower frictional properties for example, than conventional paper materials and thus permits ease of removal of the needles. Other preferred materials include paper or paperboard material such as 5 point uncoated surgical Kraft paper, also free of impurities which would adversely affect the sutures. Such a preferred paper material is uncoated surgical Kraft paper, about 5 point in weight.

As shown in FIG. 2A in conjunction with FIG. 2B, a plastic needle holder sheet 23 is inserted into cut 20 in panel 14 with upper corners inserted beneath upper cuts 22, 24 and the lower corners inserted beneath lower cuts 16, 18. Individual suture needles 102, 104, 106, 108 and 110 are positioned beneath respective tapered lift tabs 28 to retain the needles in position as shown in FIG. 2A, with each tab alternately facing the next adjacent tab. The points of the needles face downwardly and are protected by the lower portion of package material defined by cut 20. The ligatures of the sutures are temporarily gathered and set aside as shown in FIG. 2A except for the first ligature 112 which is connected to needle 102. This ligature 112 is wound into a figure "8" pattern around pins 94, 96, 98, 100 as shown.

- 12 -

Referring further to FIG. 2A, ligature 112 is alternately and continuously wrapped about pins 94, 96, 98, 100 as shown until completely wound about the pins.

Thereafter, panel 36 (with the remaining panels 34, 32, 30) is folded to the right over panel 38 and ligature 112 is shown in FIG. 4, such that ligature 114 connected to needle 104 may be alternately and continuously wrapped about pins 94, 96, 98, 100 until completely wound into a figure "8" pattern. Next, panel 34 (and the remaining panels) is folded to the left over panel 36 as shown in FIG. 5 whereby ligature 114 connected to needle 106 may be alternately and continuously wrapped around pins 94, 96, 98 and 100 to form a figure "8" pattern as shown in FIG. 5.

Referring now to FIG. 6, end panel 40 is then folded to the left over panel 34 and ligature 114 such that the relatively narrow side panel 51a defined by the double fold lines 51, 53 may encompass the combined side edges of the previously folded panels 38, 36 and 34. After folding panel 40 as shown in FIG. 6, the ligature 116 connected to needle 106 is wrapped about pins 94, 96, 98, 100 as shown until completely wound. Thereafter, panel 32 is folded over the ligature 116 as shown in FIG. 7 whereby ligature 118 attached to needle 108 may be wound in a Fig. "8" pattern about pins 94, 96, 98, 100 until completely wound. Finally, remaining panel 30 is folded over the last ligature as shown in FIG. 8.

Referring now to FIG. 9, the suture package is illustrated with the entire folded suture panels and ligatures folded downwardly behind the front panel 14. Thereafter, panel 52 is folded along the double fold lines 56, 58 such that the relatively narrow edge panel 56a encompasses all of the folded panels along the left side. Then side panel 54 is similarly folded along the double fold lines 60, 62 as shown such that the narrow edge side panel 60a encompasses the previously folded panels along the right side. Arcuate tabs 72, 74 of rear panel 54 are then inserted into slots 64, 66 of rear

- 13 -

panel 52 to retain the panel in a closed condition. Rear panel 54 also serves to retain the tapered end flap 90 of end tab 76 in position as shown in FIG. 12 which is a rear view of the suture package. FIG. 10 illustrates a front view of the package prior to folding the final rear panel 30 into position.

Referring now to FIG. 13 there is shown a cross-section of the suture package taken along lines 13--13 of FIG. 11, illustrating the panel folding sequence described above. For example, from panel 14 and plastic insert 22 are shown in cross section. Panels 38, 36, 34, 40 are shown in their folding sequence as described hereinabove. Rear panels 52, 54 are also illustrated.

Referring now to FIG. 14, there is illustrated an alternative embodiment of the blank sheet of panels 12 shown in FIG. 1B. In the embodiment 120 shown in FIG. 14, the panels and tabs are shaped to provide additional relief at the fold lines. For example, tab 90 of blank sheet 12 shown in FIG. 1B is defined by straight tapered sides, whereas corresponding tab 122 in the blank sheet shown in FIG. 14 includes arcuately configured side 122a to provide more convenient folds. Further, for example, the face panel 124 includes cuts 126, 128, 130 and 132 as shown to provide an alternative means for retaining the plastic needle retainer insert. An additional side panel flap 144 is provided and connected by double fold lines 146, 148 to the side edge of panel 30. Flap 144 is dimensioned and adapted to assist the operator during removal of the loaded package from the winding fixture, and is folded over and pressed against the loaded suture panels to hold the sutures in place while the loaded pins are withdrawn. An extra end flap 134 is also provided and connected by double fold lines 140, 142, as shown, for the purpose of providing closure of the bottom edge of the package prior to folding the last and the penultimate panels 136 and 138. This feature provides additional protection for the sutures. Tab 122, which

- 14 -

corresponds to tab 90 of blank sheet 12 shown in FIG. 1B, includes arcuately configured side 122a which provides additional relief at the fold line and for a more convenient fold. Face panel 124 includes cuts 126, 128, 130 and 132 as shown to provide an alternate means for retaining the plastic needle retainer insert. In other respects the blank sheet of folding panels shown in FIG. 14 is essentially the same as the first described embodiment.

Referring now to FIG. 15, there is illustrated another embodiment of the present invention. In this embodiment, panel 180 and the upper row of panels 152, 154, 156, 158 and 160 are provided with individual respective cut-out circular apertures 162, 164, 166, 168 and 170 to allow packing fluid, i.e., isopropyl alcohol, to be added to the package when the package is in the folded condition. Panel 150--being the rear most panel of the upper row of panels when the package is in the folded condition--is not provided with a circular aperture to prevent the packing fluid from escaping the suture retaining area of the package. The top edges of panels 152, 154, 156 and 160 have been lowered as shown as compared to the top edges of the embodiments of FIGS. 1B and 14. Such lowering provides distinct advantages in terms of suture-needle visibility and decreased bending stress on the suture. As best illustrated by FIG. 16, the upper portion of the package is open and unobstructed thereby providing greater access to the needle and suture. The top of the package also provides a greater area for the suture to curve away from the needle, resulting in less stress on the suture and needle attachment while also providing a neater appearance.

Referring again to FIG. 15, panel 180 is adjoined to panel 158 of the first row of panels by intermediate panel 188. Intermediate panel 188 is folded over upon itself along fold line 184 when folding the upper row of panels against the lower row of panels. This folded arrangement of panel 188 provides a double layer of panels between panel 180 and the

- 15 -

upper row of panels which in effect spaces panel 180 away from the upper row of panels to provide additional clearance between the needle holding panel and the loaded suture portion of the package. Such clearance aids in providing needle
5 visibility and access during operating procedures and also reduces the bending stress on the suture portion neighboring the needle. The upper portion of the package when folded is open and unobstructed, thereby providing good visibility and access to the needles and sutures. Another feature of this
10 embodiment is the length of end tab 190 which is extended to completely cover the needles when the suture package is in the final folded condition as shown in FIG. 17. FIG. 16 shows the package prior to folding end tab 190 over in the final position.

15 Alternative embodiments will now be described as shown in FIGS. 18-20. In connection with these embodiments the folding sequence is the same as described with respect to the previous embodiments and are therefore not repeated herein for the sake of brevity.

20 Referring now to FIG. 18, another embodiment of the present invention is described. In this embodiment, panels 200, 204, 206, 208 and 210 are each provided with two tapered oval apertures. Similar to the circular apertures of the
25 embodiment of FIG. 15, the tapered oval apertures 212, 214, 216, 218, 220, 222, 224, 226, 228 and 230 serve as a means to permit packing fluid, i.e., isopropyl alcohol, to be added to the package when the package is in the folded condition. The apertures also are positioned and configured to receive the
30 suture winding pins for suture wrapping, thus replacing the diamond shaped openings 31, 33, 35, 37, 39, 41, 43, 45, 47 and 49 of the embodiment of FIG. 1B.

The tapered oval apertures in FIG. 18 provide a distinct advantage during suture winding and loading. Specifically, the length of the tapered oval apertures
35 facilitates folding of the panels on the winding fixture by

- 16 -

providing a clearance such that each panel can be folded over without engagement of the portion of the panel adjacent to the suture winding pin with the winding pin. For example, during suture winding of panel 202, the suture winding pins project upwardly through the plane of the panel and through the tapered apertures. When the suture is completely wound on the panel, panel 204 is folded onto panel 202. The length of apertures 214 and 224 permit the portions of panel 204 neighboring the winding pins to clear the tops of the suture winding pins and fold onto panel 202 without interference of the pins with the panel during the folding process. As panel 204 is folded over panel 202, apertures 216 and 226 align with portions of apertures 212 and 222 and receive the winding pins on the opposite side of panel 202. Similar alignment of the winding pins and the tapered apertures occurs during subsequent folding steps without interference therebetween.

Referring now to FIG. 19, another embodiment of the present invention is described. In this embodiment, half panels 234, 236 and 238 are provided to reduce the overall bulk of the suture package when the package is in the completely folded condition. The half panels also prevent the loaded sutures from catching on the packing fluid aperture.

Referring now to FIG. 20, another embodiment of the present invention is illustrated. In this embodiment the end closure tab is moved from its original location wherein it is attached to the first panel on the first row of panels (compare panel 244 of FIG. 19) to an alternative location wherein it is configured as shown at 246 and attached to panel 174 of the second row of panels by double fold lines 250, 252 to allow for the thickness of the package when folded over in the final position. This feature ensures that upon the lifting of end tab 248 to expose the loaded needles, the lifting motion of the end tab--which is now secured to the second row of panels--will prevent inadvertent removal of the interior first row of panels from the closed suture package which might

- 17 -

otherwise occur as a result of the reduced dimensions of interior panels 234, 236, 238. Another feature of this embodiment is that the length of flap 246 is sufficiently extended to assist the operator during removal of the loaded package from the winding fixture, and to hold the sutures in place while the loaded pins are withdrawn.

The above embodiments have been shown and described as examples of the present invention, and other modifications and embodiments are contemplated within the spirit of scope of the present invention as defined by the following claims.

- 18 -

WE CLAIM:

1. A suture package which comprises:
 - a) a first row of a plurality of panel members of substantially similar shape foldably connected to each other and arranged to fold upon each other to form at least three individual suture compartments between pairs of adjacent panel members, each said compartment being arranged to accommodate at least one flexible suture therein; and
 - b) a second row of a plurality of panel members connected to one panel member of said first row of panel members, said second row of panel members foldably connected to each other and foldable independent of said first row, said second row of panel members further being foldable in a manner to substantially enclose said first row of panel members folded upon each other.
2. The suture package according to claim 1 wherein each panel member of said first row is generally rectangular and is connected to the next adjacent panel member on a longer side.
3. The suture package according to claim 1 wherein each panel member of said second row is generally rectangular and is connected to the next adjacent panel member on a longer side.
4. The suture package according to any one of claims 1 or 3 wherein said panel members of said second row are connected to each other by a double fold line each of which defines edge panel members to encompass said first row of panel members folded upon each other.
5. The suture package according to any one of claims 1, 2 or

- 19 -

4 wherein said first row of panel members contains at least three panel members.

6. The suture package according to any one of claims 1, 3, or 4 wherein said second row of panel members contains at least two panel members.

7. The suture package according to any one of claims 1, 3, 4 or 6 wherein said second row of panel members contains three panel members.

8. The suture package according to claim 7 wherein said three panel members of said second row of panel members includes a first centrally positioned panel member and two adjacent panel members foldably connected to said centrally positioned panel member.

9. The suture package according to claim 8 wherein said centrally positioned panel member of said second row of panel members is connected to one panel member of said first row of panel members along respective shorter sides thereof.

10. The suture package according to claim 9 wherein said second row of panel members is folded along said shorter side of said centrally positioned panel member, said adjacent panel members of said second row being respectively folded around said folded panel members of said first row to enclose said first row.

11. The suture package according to any one of claims 7 to 9 wherein said adjacent panel members of said second row of panel members include means for retaining said second row of panel members in a folded condition around said folded first row of panel members.

- 20 -

12. The suture package according to claim 11 wherein said retaining means of said adjacent panel members comprises at least two slots in one of said adjacent panel members and at least two correspondingly dimensioned and configured cuts in a second of said adjacent panel members to define tabs, said tabs being positioned and dimensioned for entry into said slots in said second panel member to retain said panel members of said second row in said folded condition.

13. The suture package according to claim 12 wherein said cuts in said second panel member are arcuately configured to define respectively arcuate tabs.

14. The suture package according to claim 10 wherein said first row of panel members contains at least six panel members.

15. The suture package according to any one of claims 1, 2, 5 or 10 wherein an end flap is connected to a shorter side of at least one of said panel members of said first row such that when said first row of panel members are in a fully folded condition to form said at least three suture compartments, said end flap folds over the shorter side to at least partially enclose said at least three suture compartments at first end portions thereof.

16. The suture package according to claim 15 wherein said end flap includes a generally tapered end portion connected along a fold line, said tapered end portion adapted to fold along said fold line to assist in retaining said end flap in a folded condition.

17. The suture package according to any one of claims 1, 2, 5, 10 or 15 wherein a second end flap is connected to a shorter side of at least one panel member of said first row

- 21 -

such that when said first row of panel members are in a fully folded condition to form said at least three compartments, said second end flap folds along the shorter side to at least partially enclose said at least three suture compartments at second end portions thereof.

18. The suture package according to claim 17 wherein said second end flap is connected to the shorter side of said at least one panel member of said first row by a double fold line.

19. The suture package according to any one of claims 1, 3, 4 or 6 to 11 wherein one of said panel members of said second row of panel members is provided with means for retaining at least two suture needles.

20. The suture package according to claim 19 wherein said means for retaining at least two suture needles is a substantially planar insert member adapted for attachment to said one of said panel members of said second row of panel members.

21. The suture package according to claim 20 wherein said substantially planar insert member is of resilient material and has portions cut and lifted from the plane of said insert member, respective pluralities of said cut portions being dimensioned and positioned to engage respective portions of suture needles to retain the needles in respective fixed portions whereby the needles are positioned in generally spaced relation and individual flexible suture portions are respectively positioned in individual compartments formed by adjacent folded panel members of said first row.

22. The suture package according to any one of claims 1, 2, 5 or 14 to 18 wherein an end flap is connected to a

- 22 -

shorter side of at least one panel member of said first row such that when said first row of panel members are in a fully folded condition to form said at least three suture compartments and said second row of panel members are folded to substantially enclose said first row said end flap folds onto said one panel member of said second row having said retaining means to at least partially cover suture needles retained thereby.

23. The suture package according to claim 22 wherein said end flap is connected to the shorter side of said at least one panel member of said first row by a double fold line.

24. The suture package according to any one of claims 1 to 23 wherein said first and second rows of panel members are respectively connected to each other by an intermediate panel member, said intermediate panel member attached to the short sides of one panel member in each row.

25. A suture package, which comprises:

- a) a first row of at least four generally rectangular shaped panel members foldably connected to each other on longitudinal sides thereof and arranged to fold upon each other to form at least three individual suture compartments between pairs of adjacent panel members, each said suture compartment dimensioned and shaped to accommodate an individual suture therein;
- b) a second row of at least three generally rectangular panel members foldably connected to each other on the longitudinal sides thereof;
- c) said first row of panel members being connected to said second row of panel members on the short sides of

- 23 -

one panel member in each row; and
d) said second row of panel members foldable independent of said first row of panel members and arranged to receive and enclose said first row folded upon each other.

26. A suture package for storing a plurality of individual suture portions, which comprises at least two rows of panel members, at least a first of said rows having at least four generally rectangular panel members foldably connected to each other and arranged to fold upon each other to form at least three individual suture compartments between pairs of adjacent panel members, each said suture compartment dimensioned to accommodate an individual suture therein, at least a second of said rows having at least three generally rectangular panel members foldable independent of said panel members of said at least first row and arranged to fold in a manner to substantially enclose said at least first row of panel members folded upon each other.

27. The suture package according to any one of claims 15 or 26 wherein each said suture compartment is dimensioned to accommodate an individual suture portion in a coiled configuration.

28. The suture package according to claim 26 further comprising means associated with one of said panel members for retaining at least two suture needles attached to the individual suture portions.

29. A suture package for storing at least two flexible suture portions, which comprises at least two rows of panel members connected to each other, at least a first row of said at least two rows including a plurality of panel members

- 24 -

arranged to fold upon each other to form at least three individual suture compartments between pairs of adjacent panel members, each said compartment dimensioned to accommodate a single flexible suture therein, at least a second row of said at least two rows of panel members foldable independent from the remaining rows and arranged to fold in a manner to at least partially encompass the remaining rows of panel members folded upon each other.

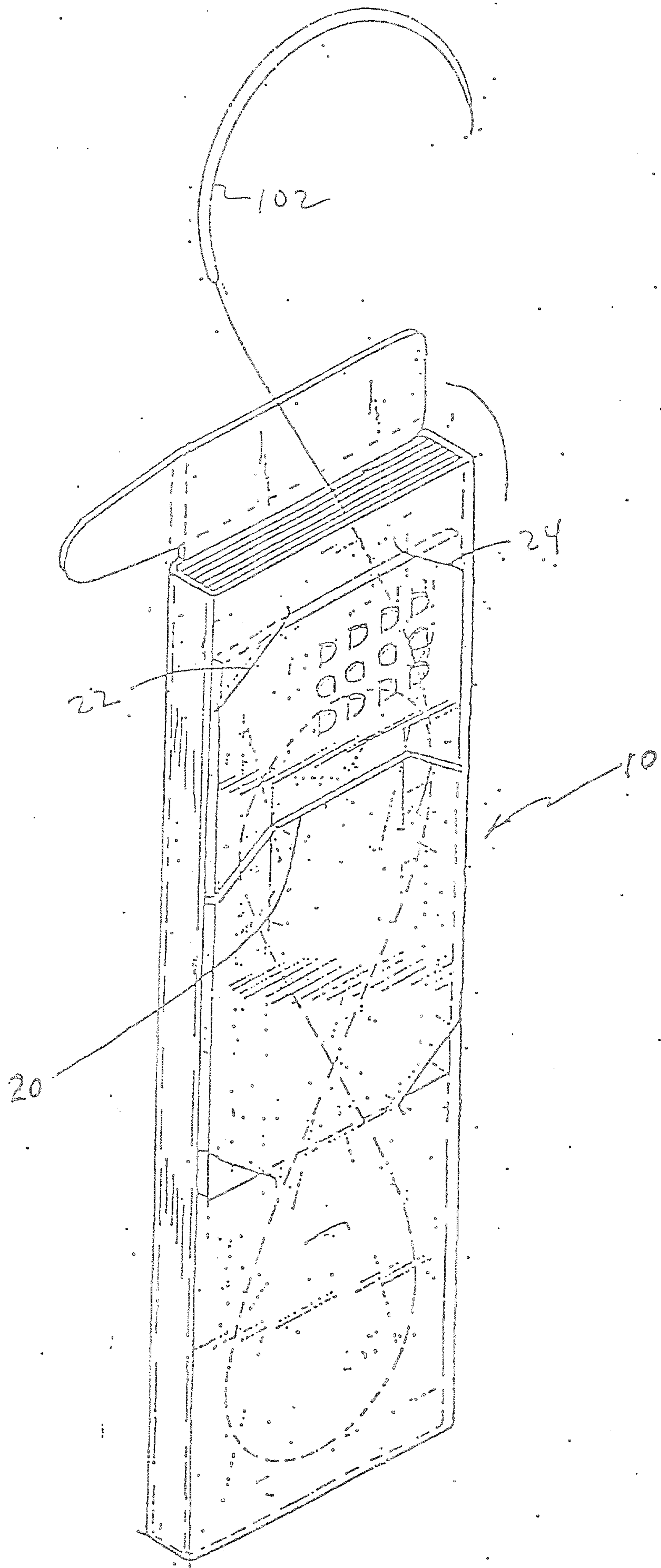

FIG. 1A

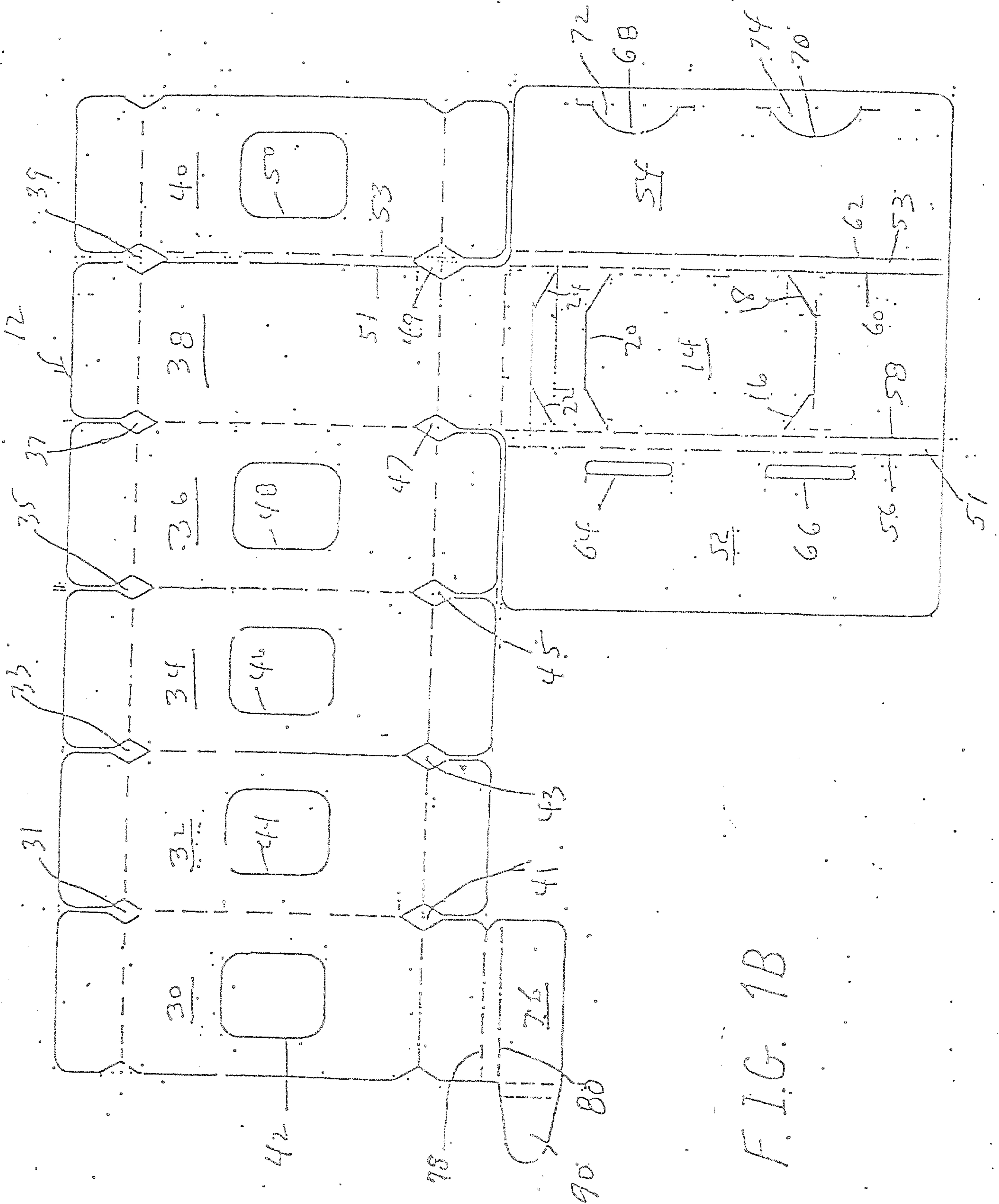
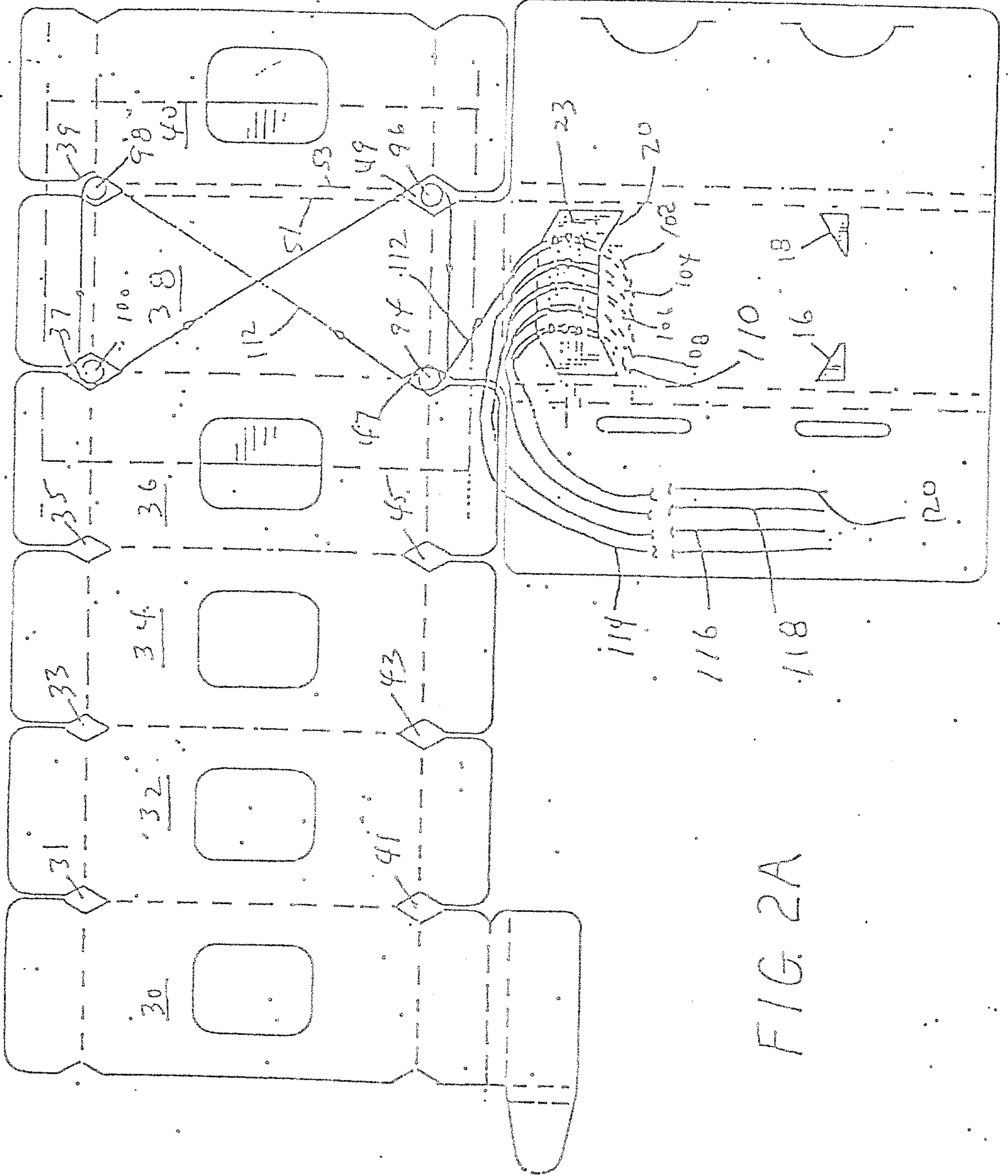

FIG. 1B

3-a



3-a

FIG. 2A

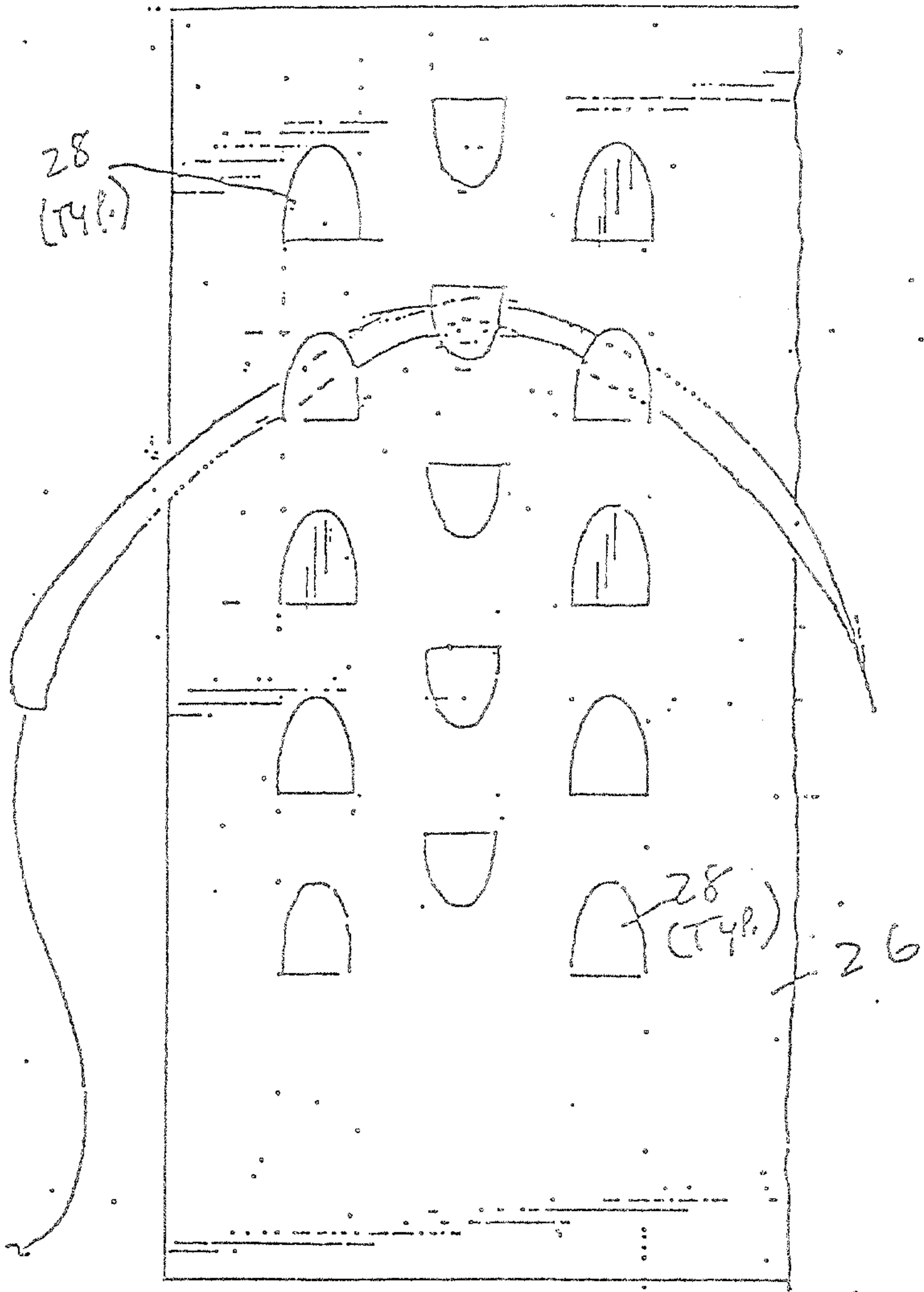

FIG 2B

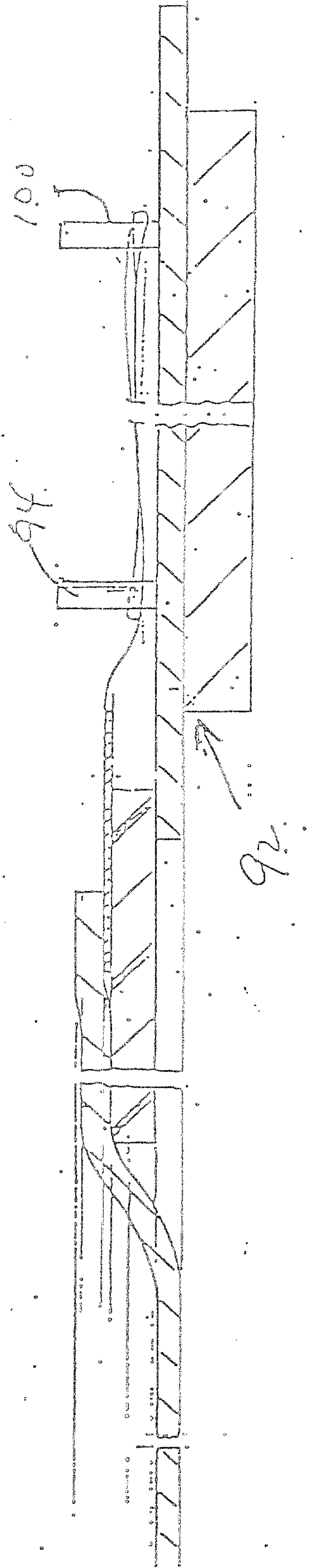

FIG. 3

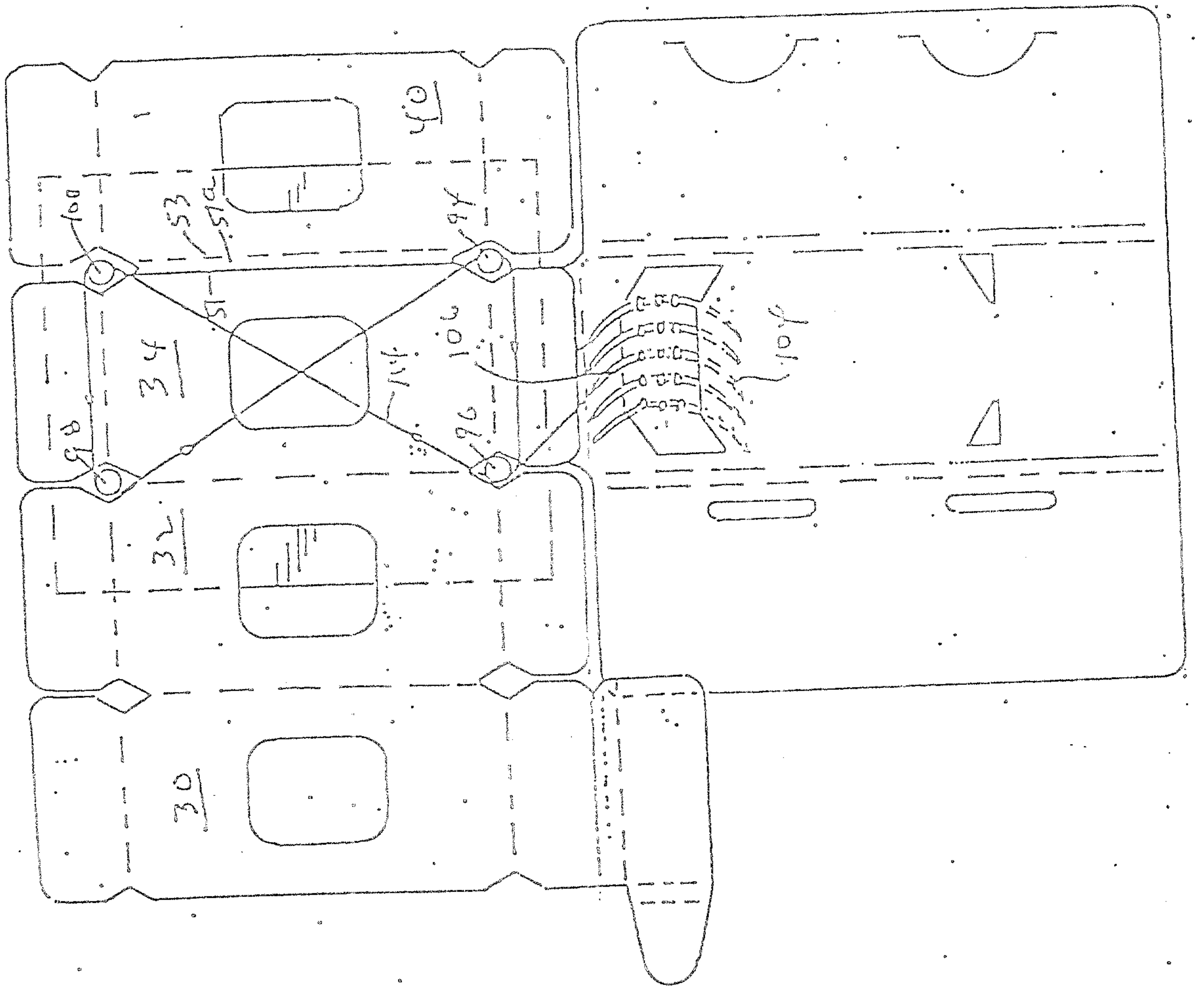

FIG. 5

FIG. 6

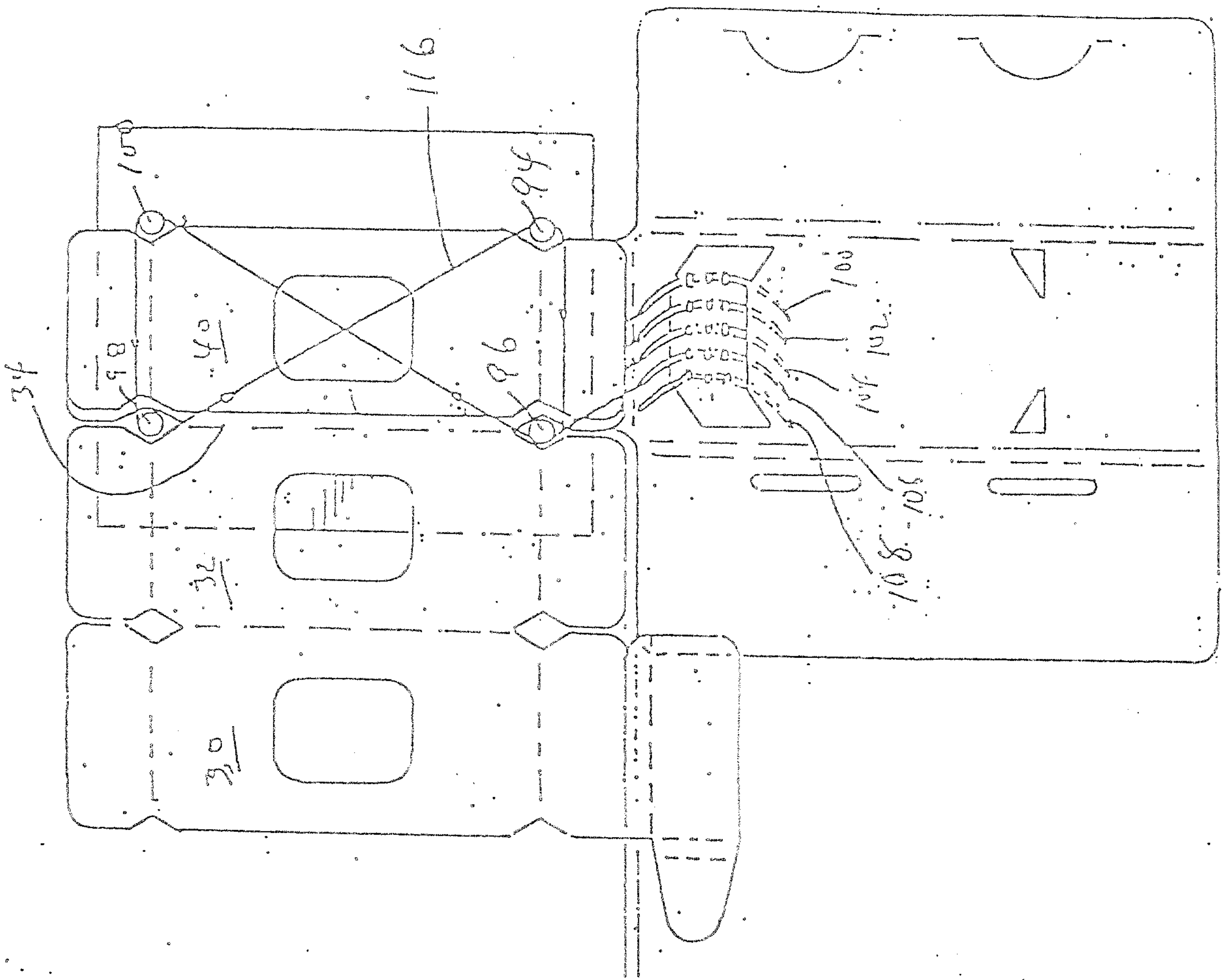

FIG 8

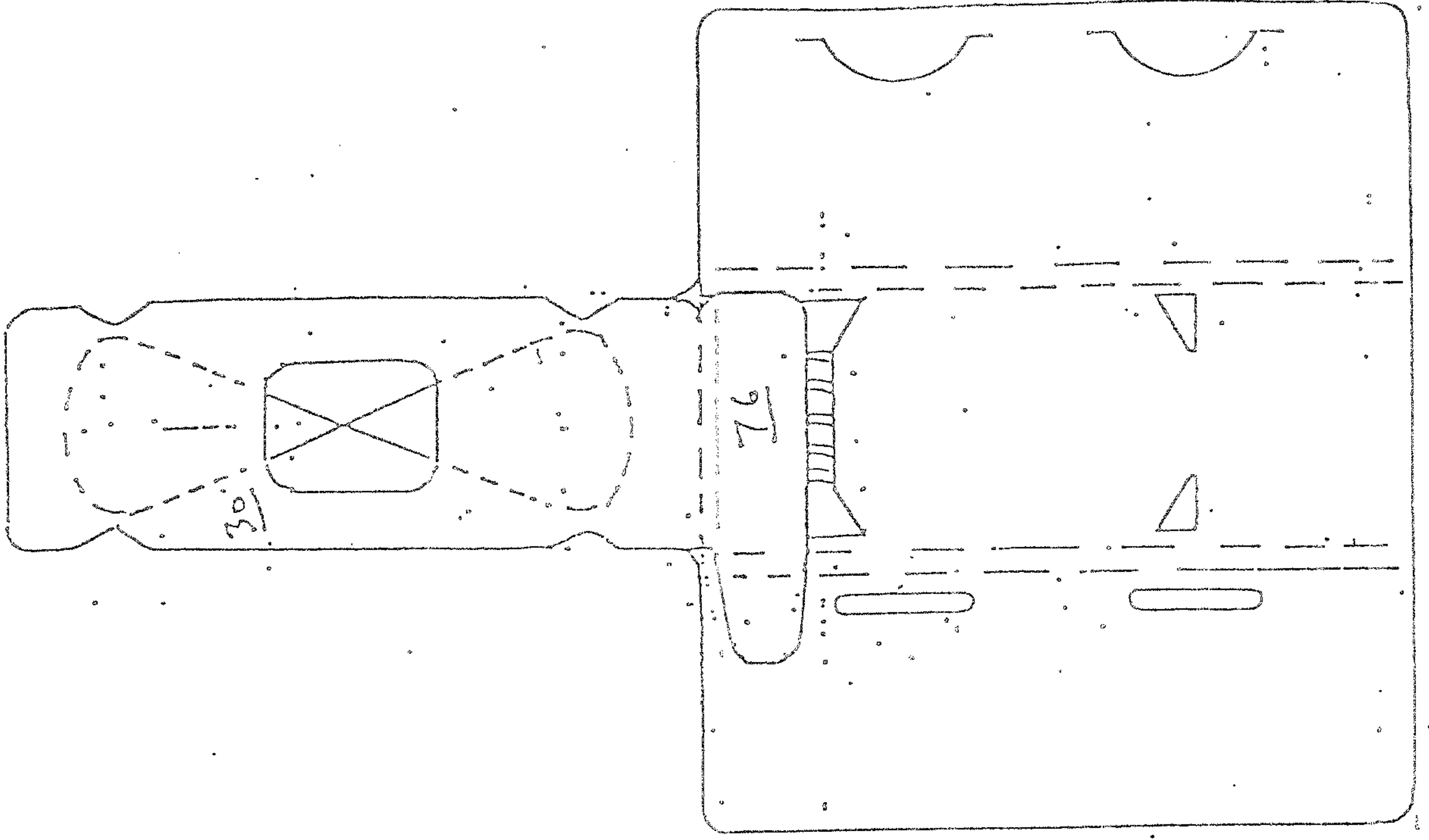

FIG. 7

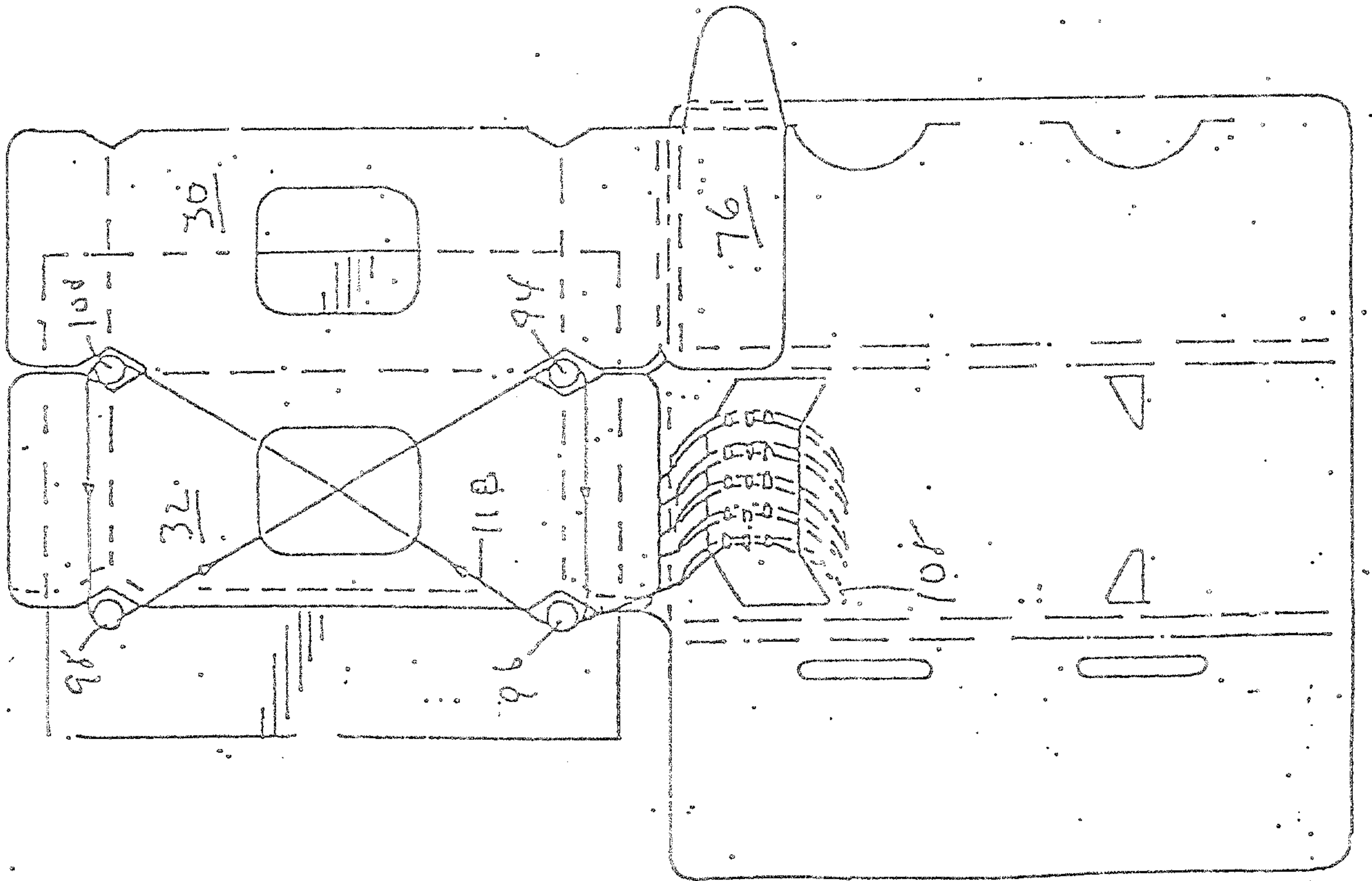

FIG. 9

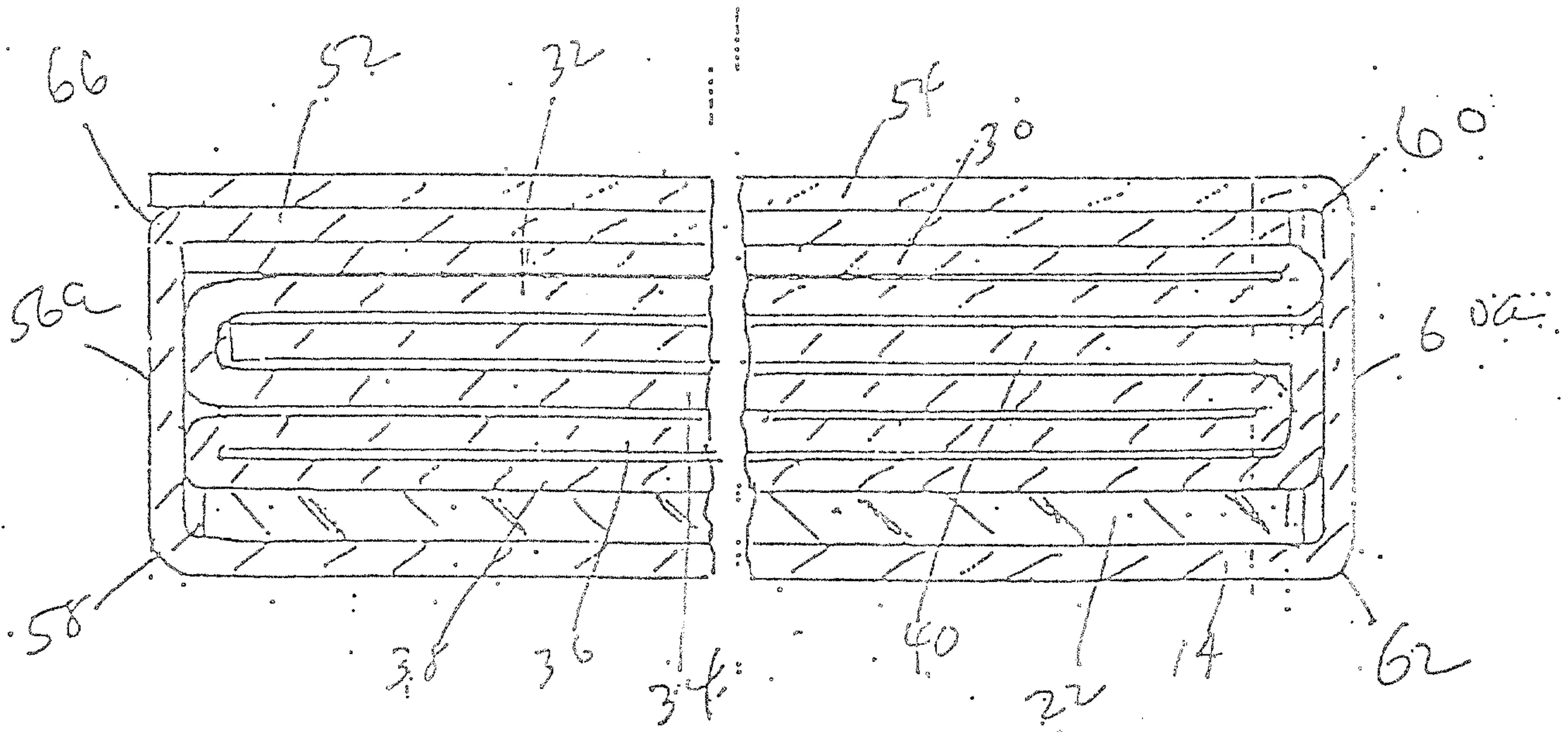
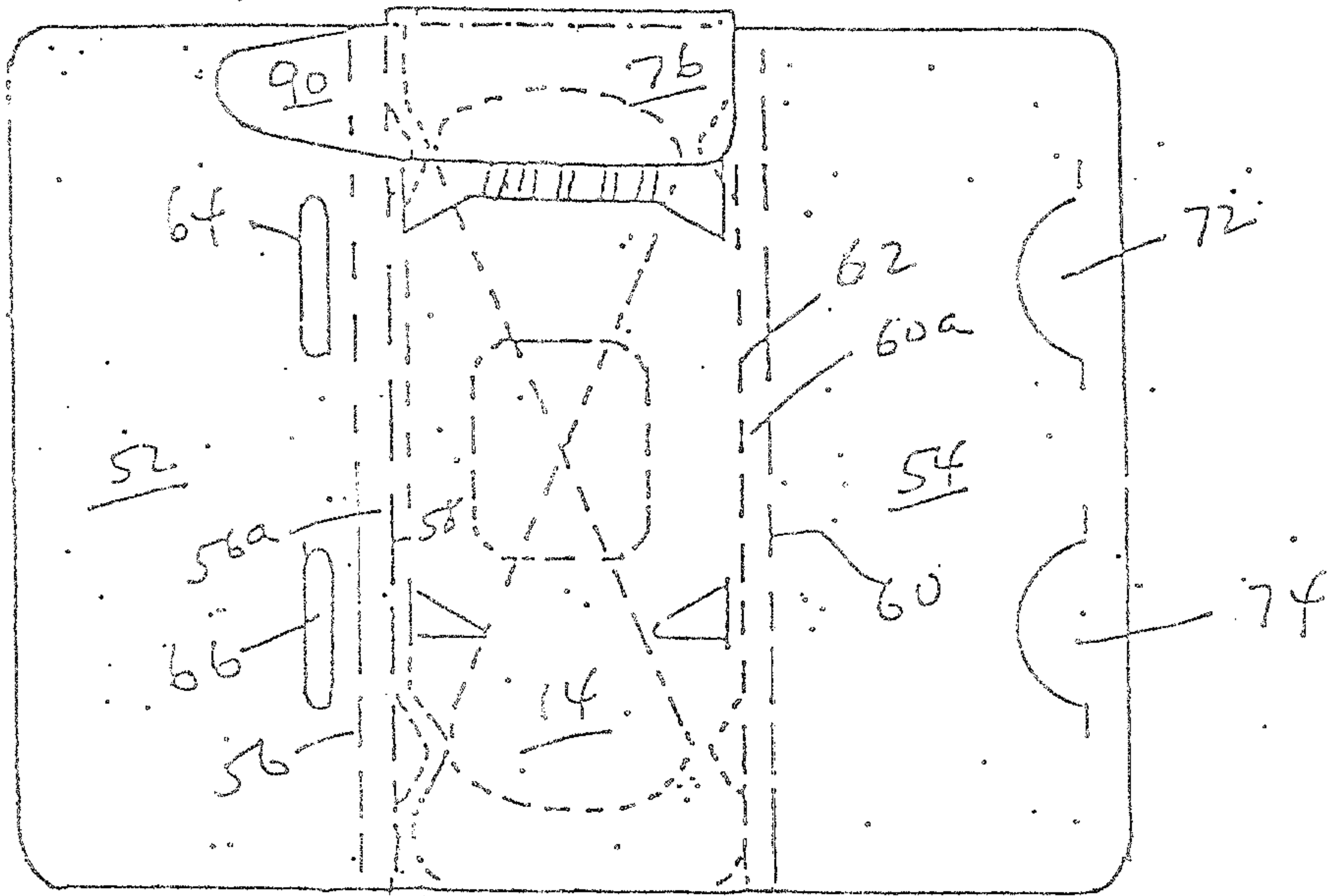

FIG. 13

FIG. 10

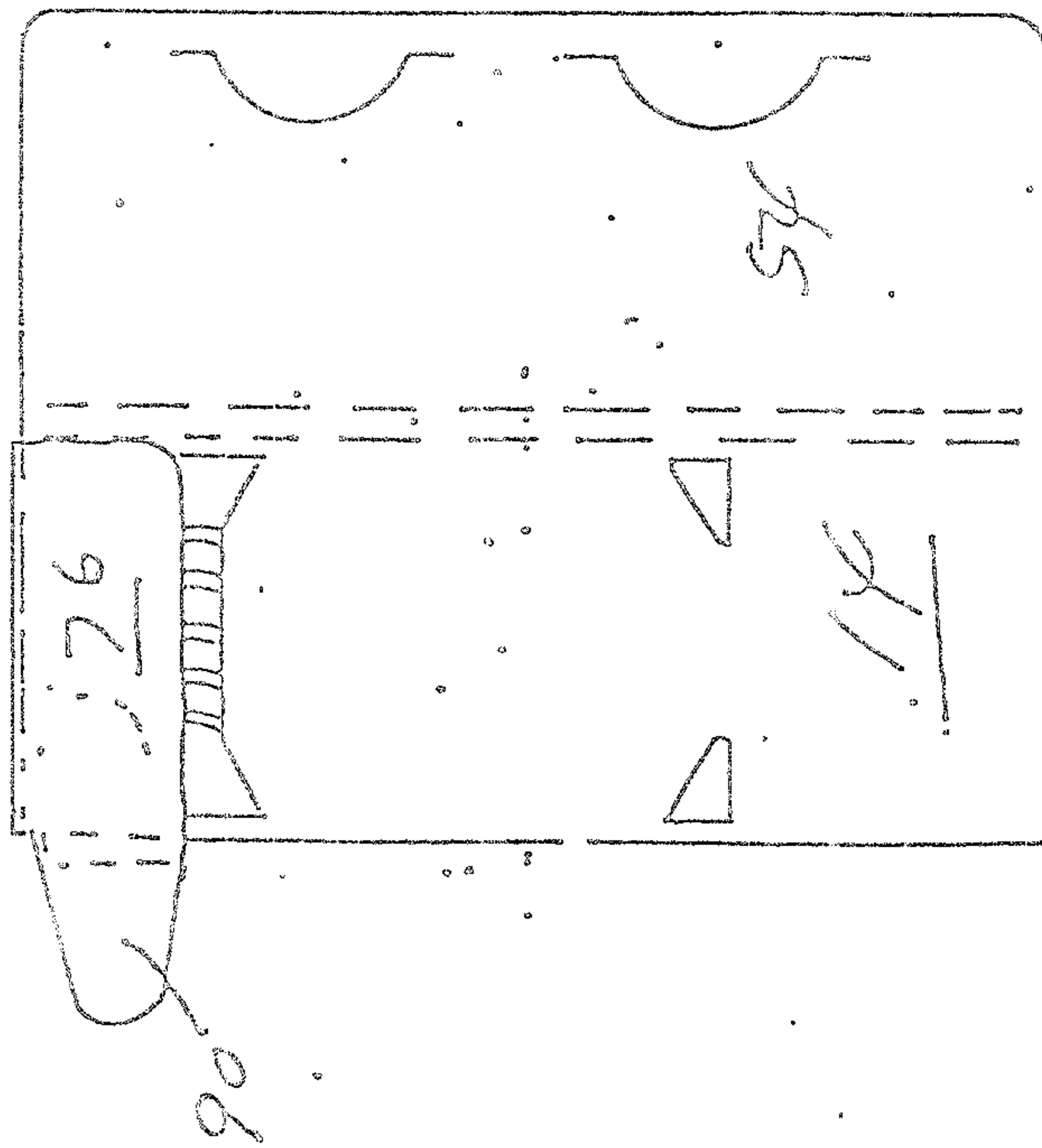

FIG. 11

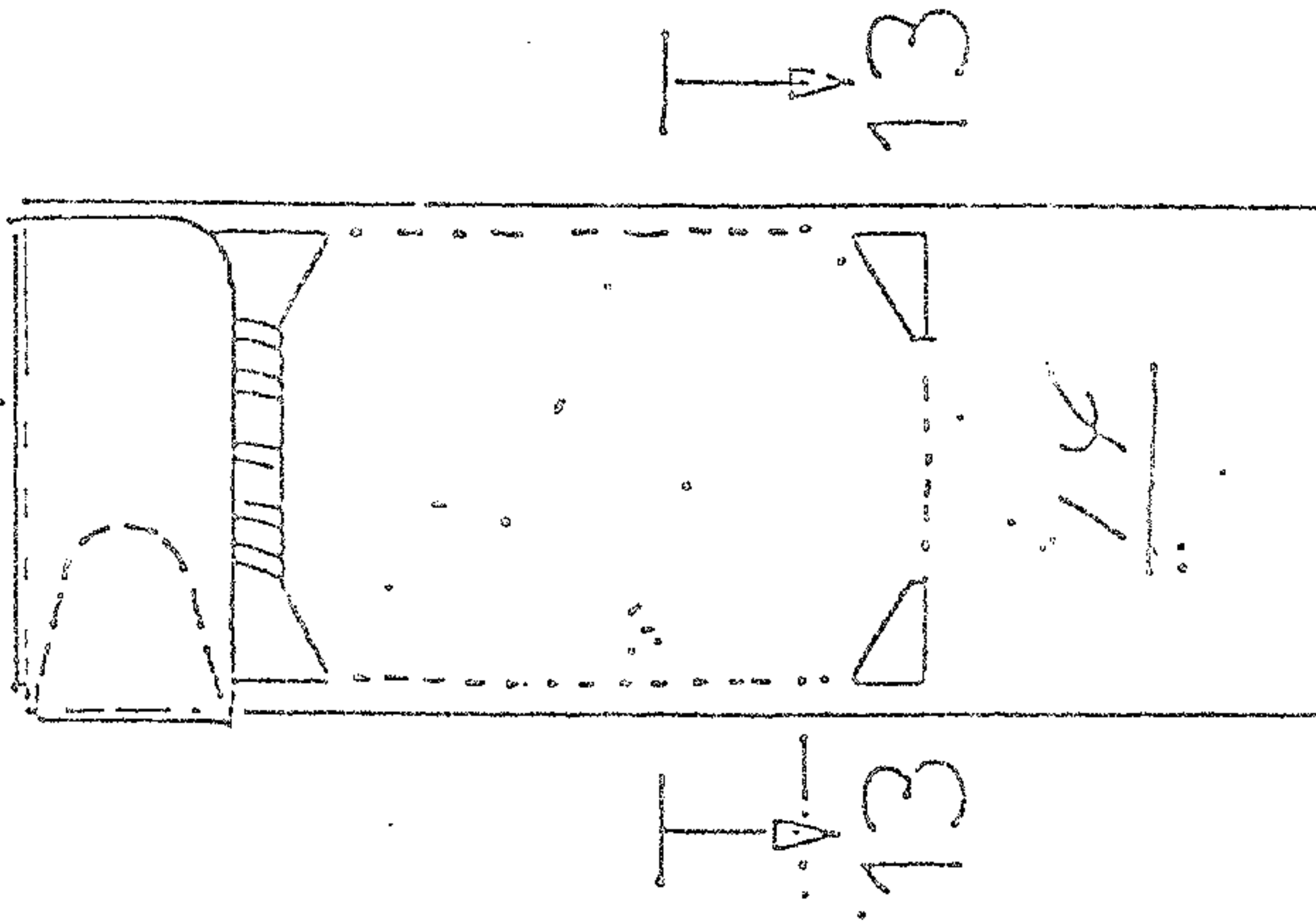
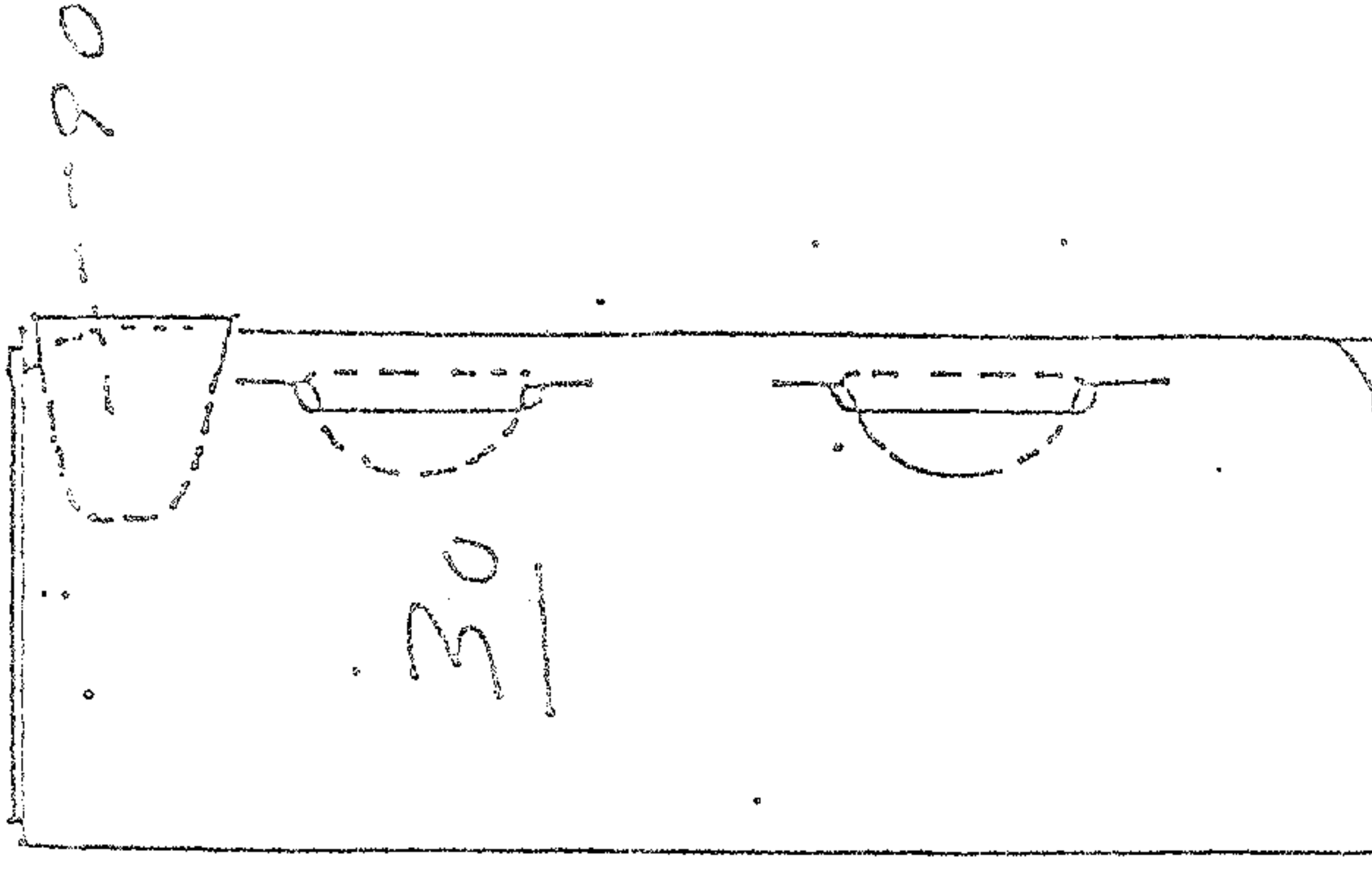

FIG. 12



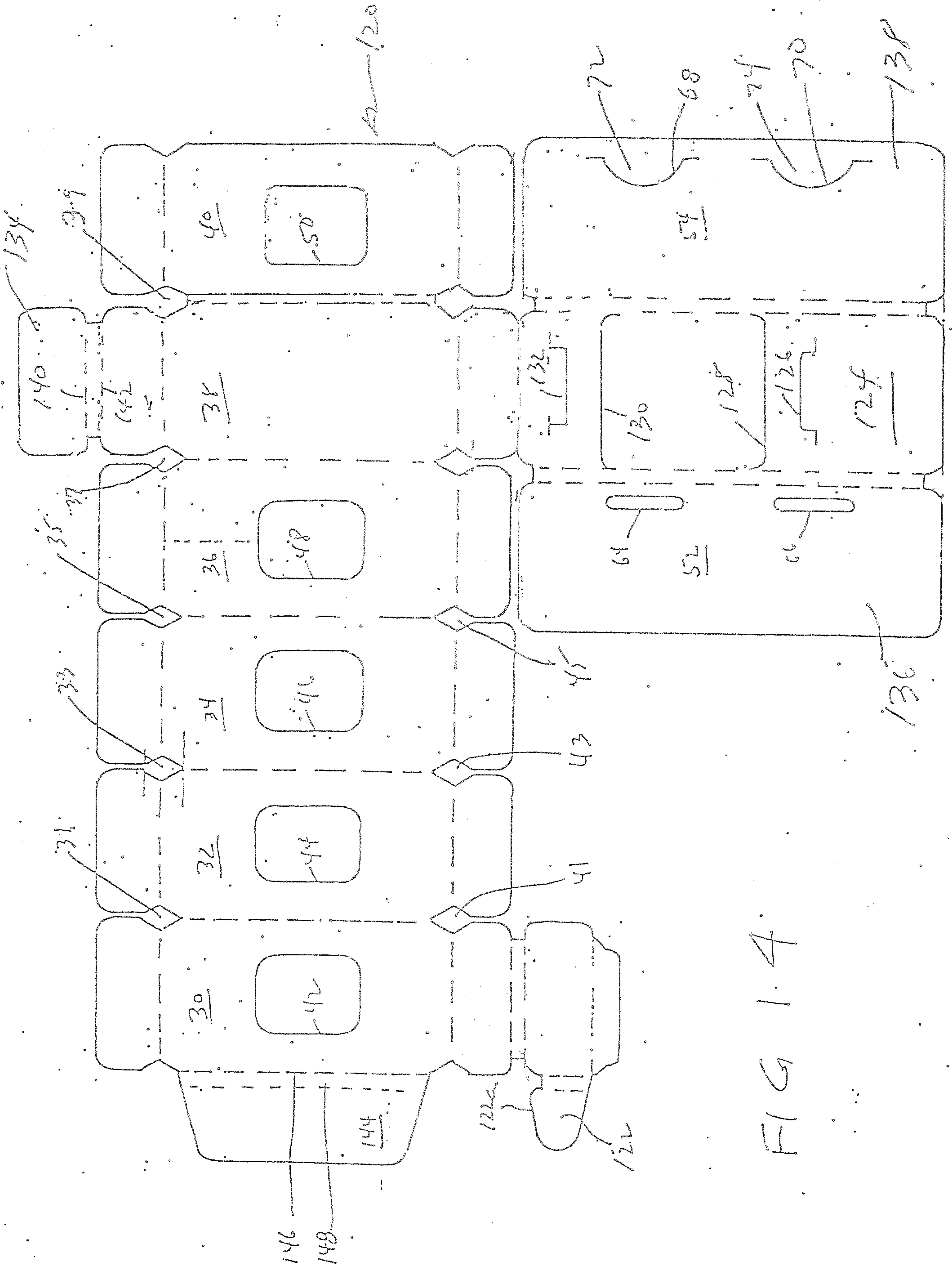

FIG 1.4

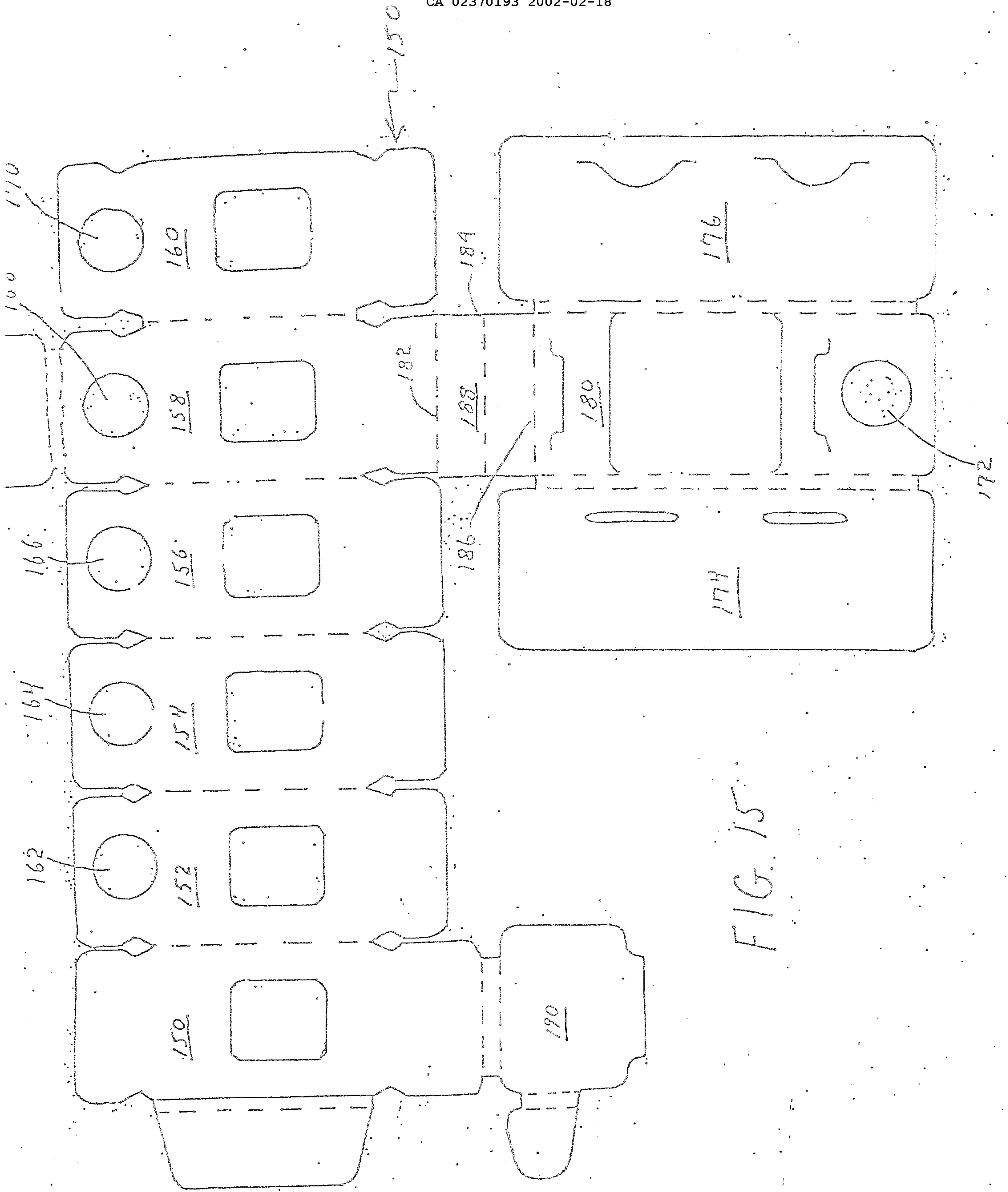

FIG. 15

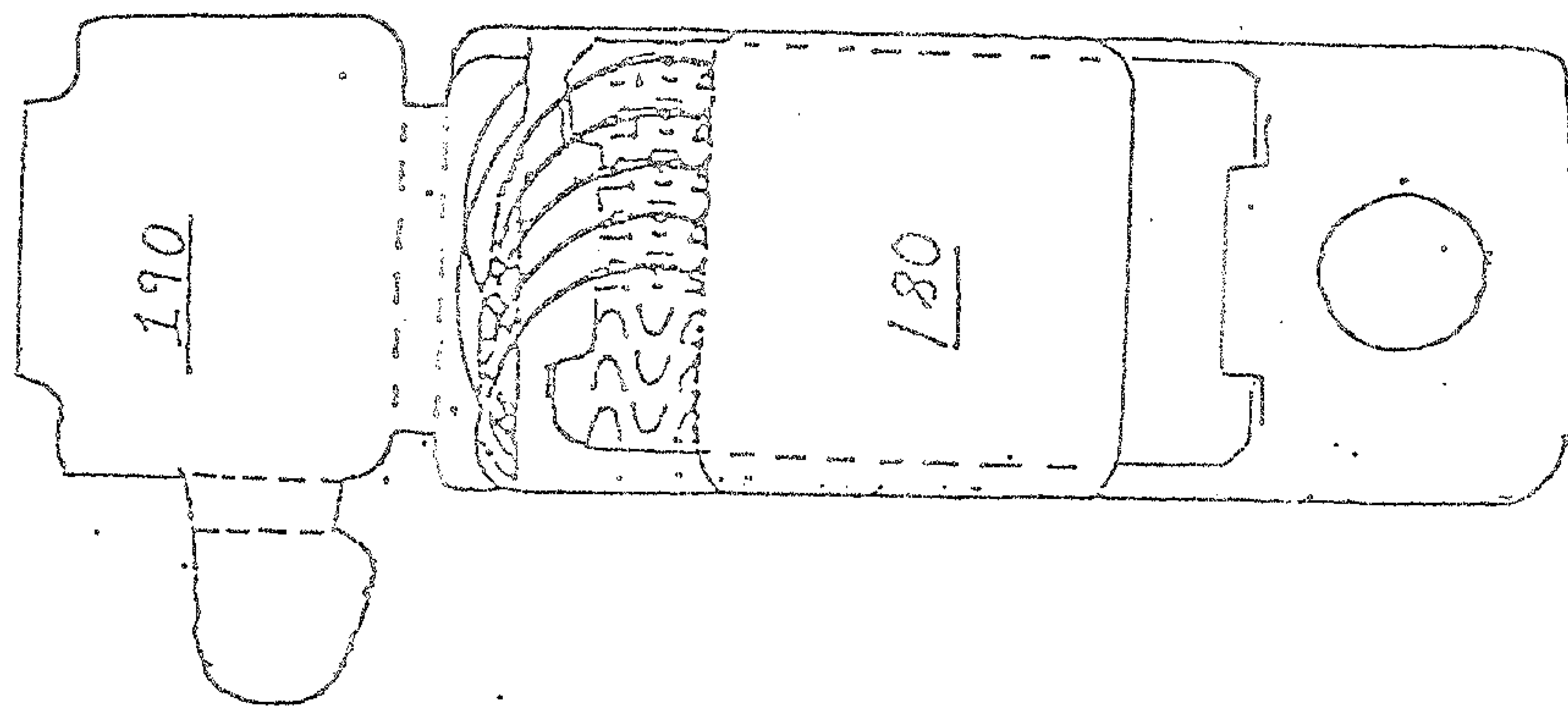

FIG. 16

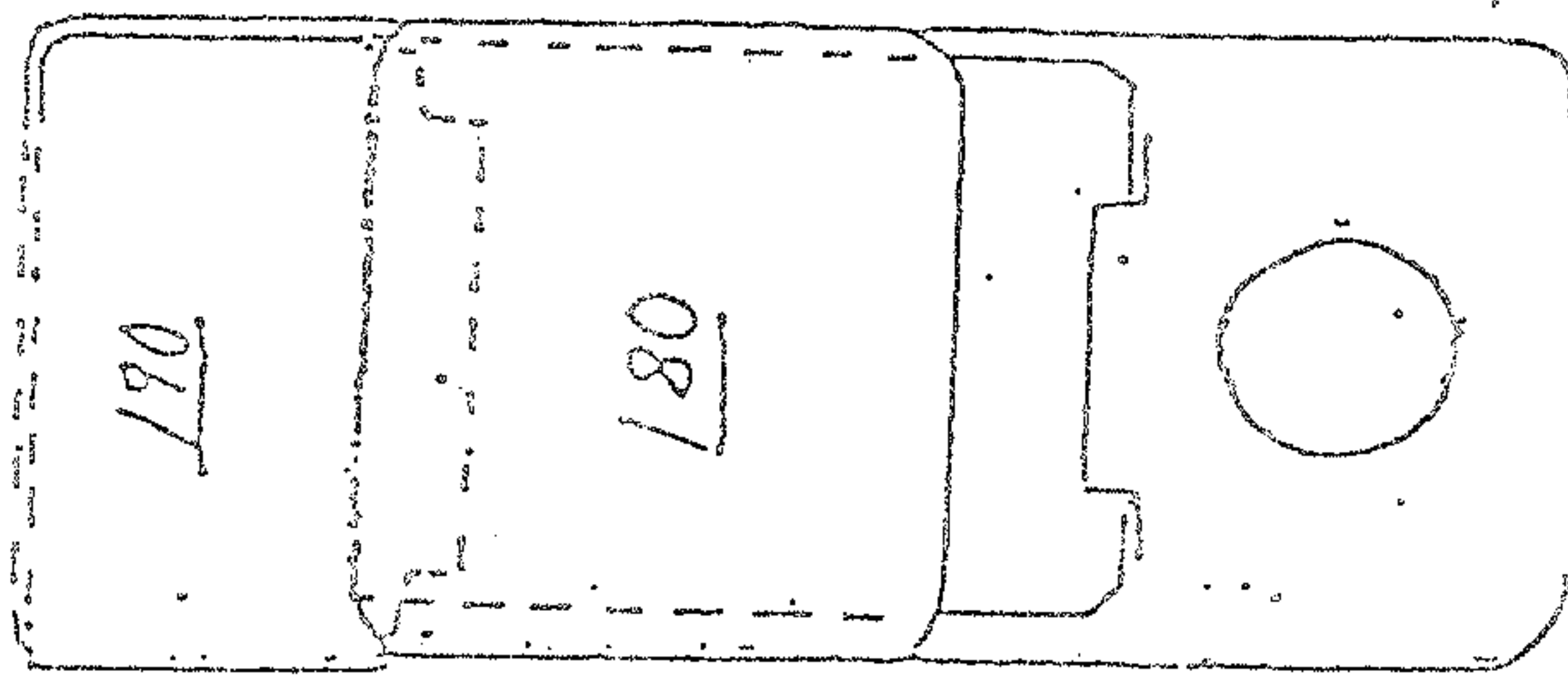

FIG. 17

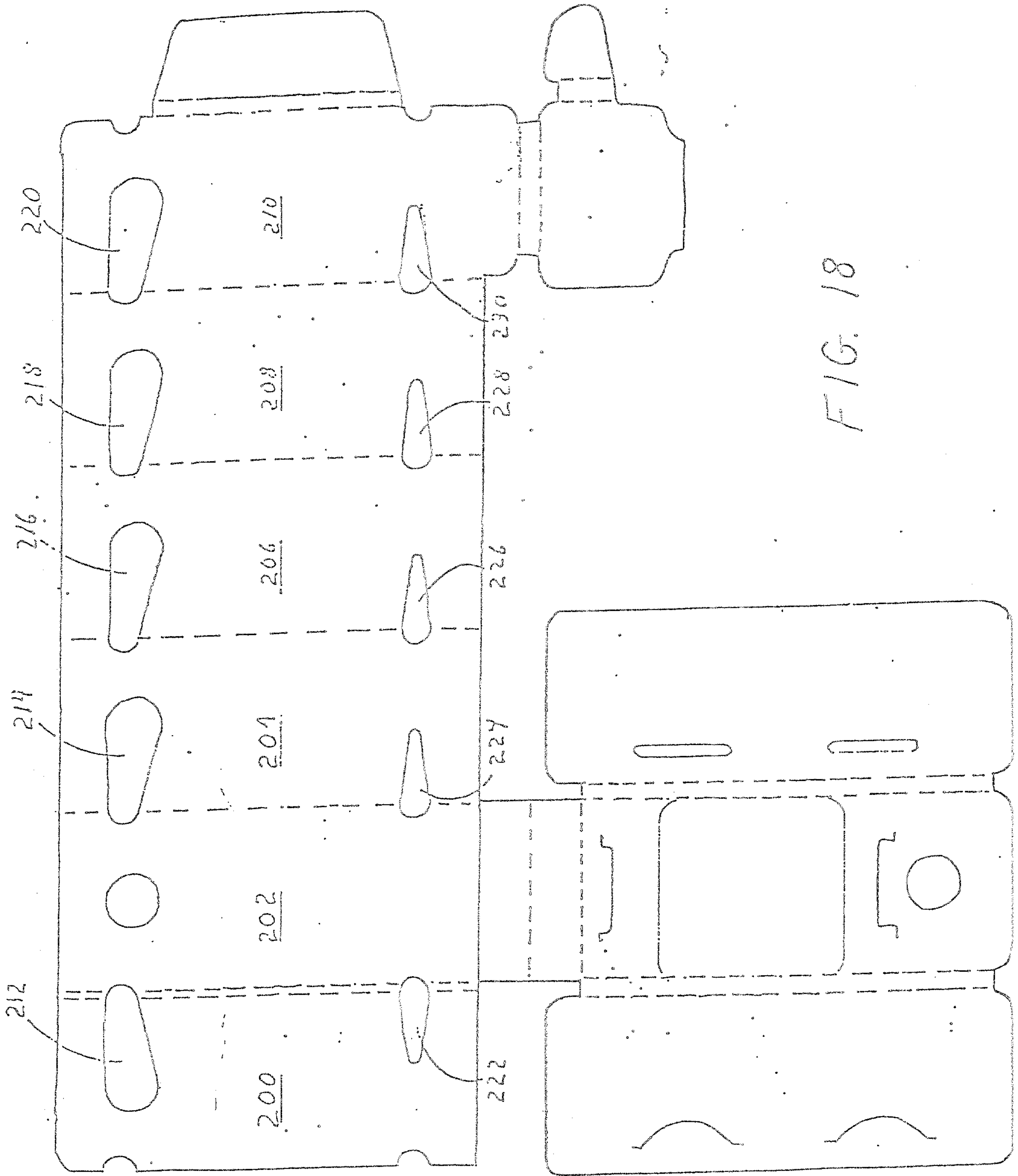

FIG. 18

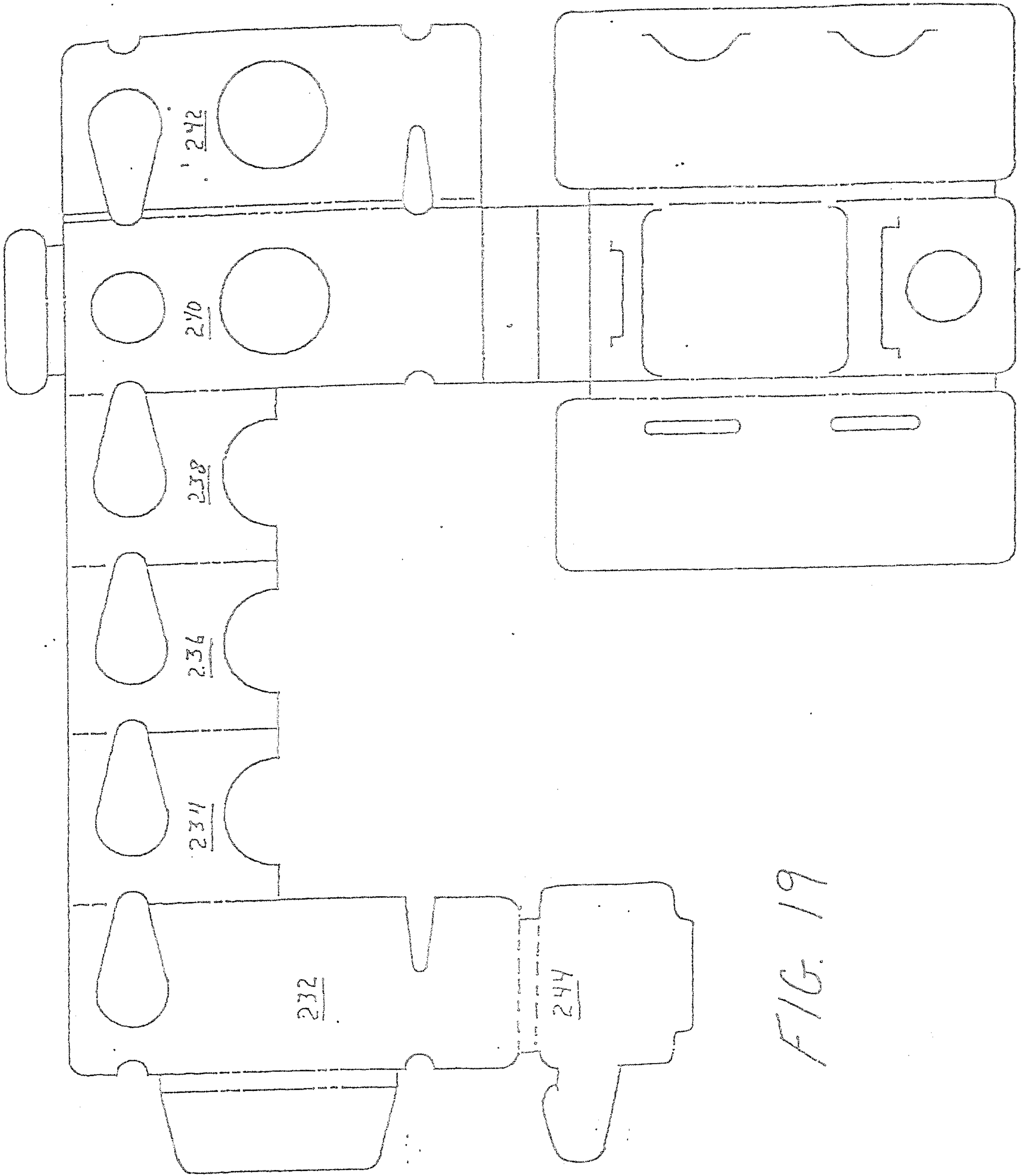

FIG. 19

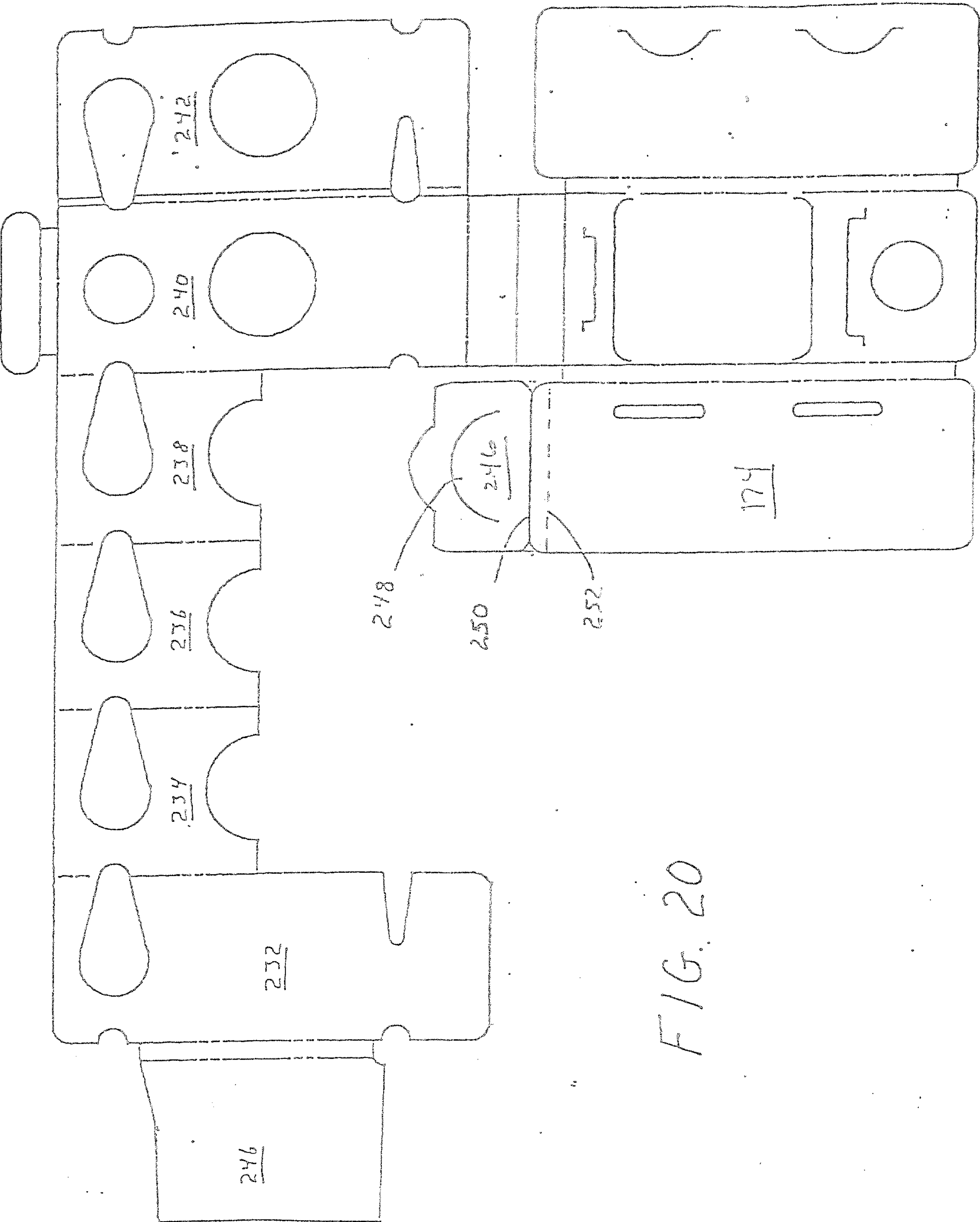

FIG. 20

