

W. H. SNOW.
 OPERATING MECHANISM FOR WIRE STRETCHERS.
 APPLICATION FILED NOV. 3, 1916.

1,236,616.

Patented Aug. 14, 1917.

2 SHEETS—SHEET 1.

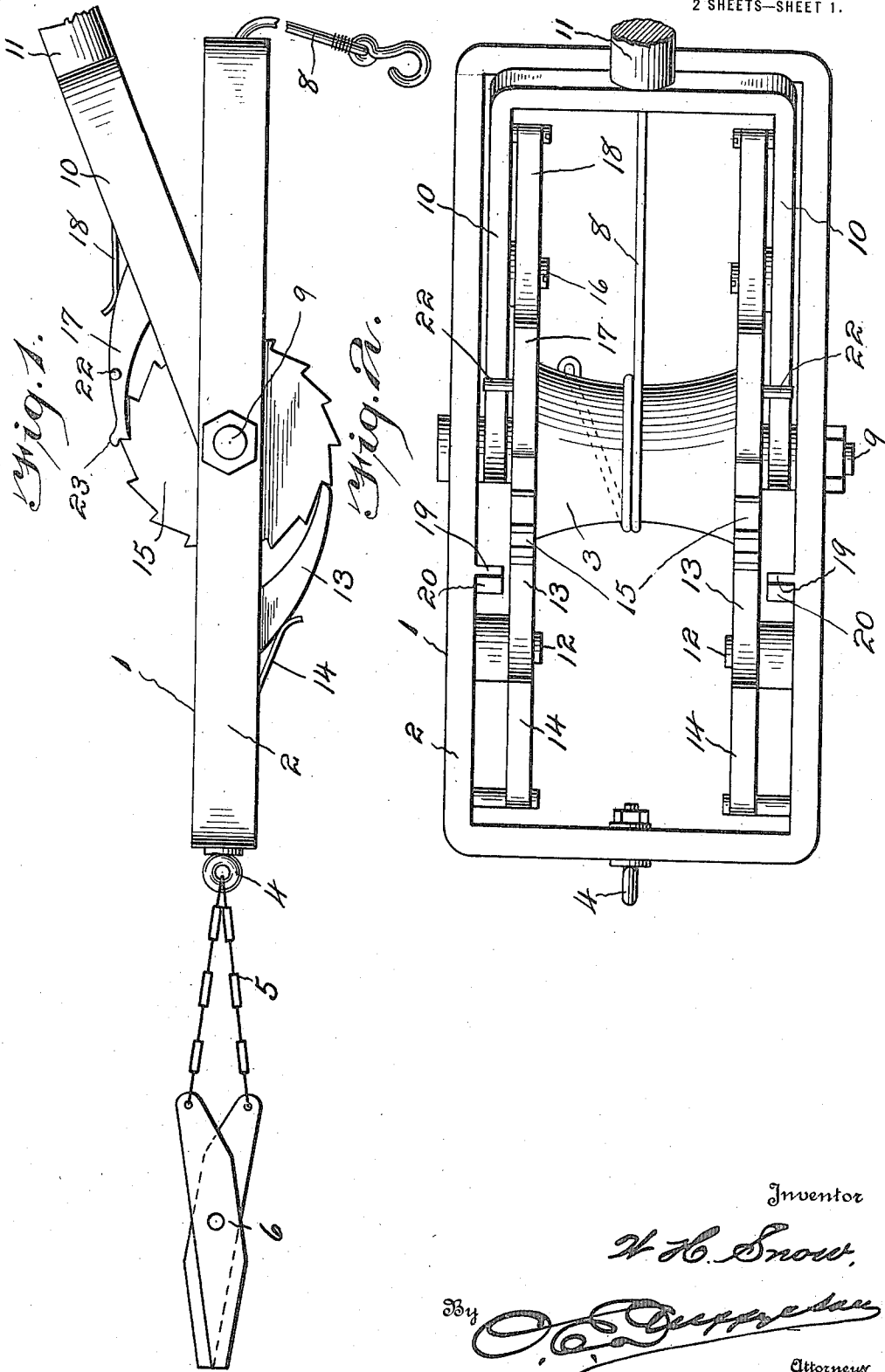

Inventor

W. H. Snow,

By

[Handwritten signature]

Attorneys

W. H. SNOW.
OPERATING MECHANISM FOR WIRE STRETCHERS.
APPLICATION FILED NOV. 3, 1916.

1,236,616.

Patented Aug. 14, 1917.

2 SHEETS—SHEET 2.

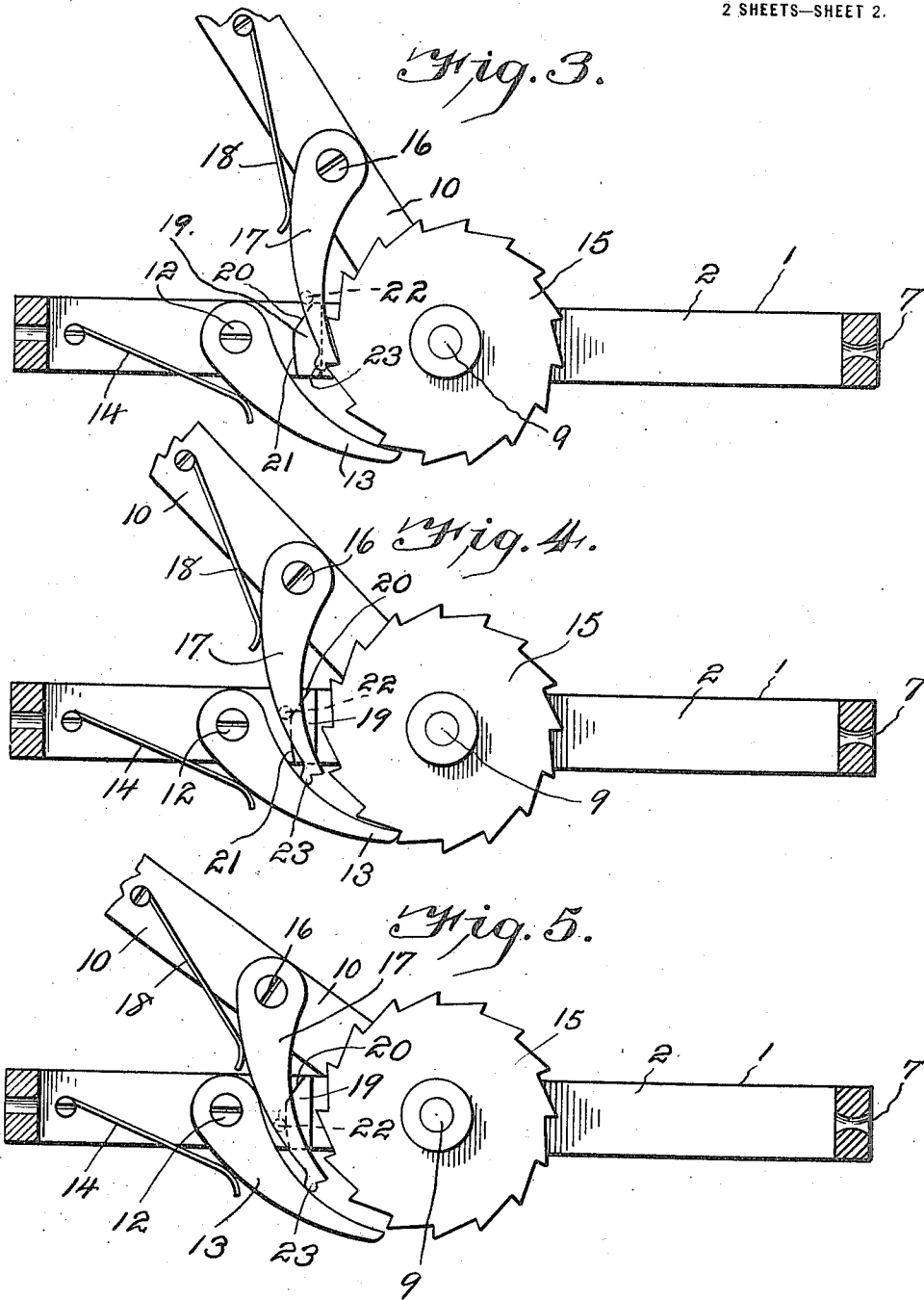

Inventor

W. H. Snow

By

Attorney

UNITED STATES PATENT OFFICE.

WALTER H. SNOW, OF ARCADIA, FLORIDA.

OPERATING MECHANISM FOR WIRE-STRETCHERS.

1,236,616.

Specification of Letters Patent. Patented Aug. 14, 1917.

Application filed November 3, 1916. Serial No. 129,383.

To all whom it may concern:

Be it known that WALTER H. SNOW, a citizen of the United States, residing at Arcadia, in the county of De Sota and State of Florida, has invented certain new and useful Improvements in Operating Mechanism for Wire-Stretchers; and I do declare the following to be a full, clear, and exact description of the invention, such as will enable others skilled in the art to which it appertains to make and use the same, reference being had to the accompanying drawings, and to the letters and figures of reference marked thereon, which form a part of this specification.

This invention relates to wire stretchers and the like and has for its object to provide an improved device for the quick and effective stretching of wires and has for its further object the construction of a wire stretching device which is particularly simple in construction, cheap and easy to manufacture, strong, durable and efficient.

With these and other objects in view, the invention consists in the novel construction of the wire stretcher and particularly in the novel construction and arrangement of the parts for disengaging and holding in disengagement the pawls from the ratchet wheels of the drum.

Referring to the accompanying drawings: Figure 1 is a side elevation of a wire stretching machine constructed in accordance with this invention, the operative handle being broken away in order to enlarge the view.

Fig. 2 is a top plan view of the same.

Fig. 3 is a longitudinal sectional view through the frame, the mechanism being shown in elevation.

Fig. 4 is a similar view illustrating the drum actuating yoke in position for releasing the drum actuating pawls from the drum ratchets, and

Fig. 5 is a similar view illustrating the extreme position of the operating handle for disengaging both the actuating pawls and the ratchet holding pawls from the drum ratchets.

Like numerals of reference indicate the same parts throughout the several figures, in which—

1 indicates the machine comprising the frame 2 shaped as shown in Fig. 2, in which frame the wire stretching drum 3 is journaled. One end of the frame 2 is provided

with a swivel eye bolt 4 to which the chain 5 is connected, said chain 5 being also connected to the wire grip 6. The opposite end of the frame 2, is provided with an opening 7 (Fig. 3), through which the wire 8 leads to the drum 3.

Pivoted on the shaft 9 of the drum 3 is the yoke 10 of the handle 11, said handle being of usual form. Pivoted on each side of the frame 2, at 12, are the two ratchet holding pawls 13, which under influence of leaf springs 14 normally hold the pawls 13 into engagement with the teeth of the ratchet wheels 15, which are fast on the shaft 9 in the manner as shown in Fig. 3.

Pivoted at 16, on each arm of the yoke 10 are the two ratchet actuating pawls 17, which under influence of the leaf springs 18 on the yoke 10 normally hold the said pawls 17 into engagement with the teeth of the ratchets 15. The construction of the ratchet wheels 15 being such that the handle 11 is free to rock in one direction and carry its pawls 17 over the ratchet teeth. When, however, the handle 11 is rocked toward the swivel eye 4, the pawls 17 engage the ratchet teeth and cause the ratchets and drum 3 to rotate to wind up the wire 8 thereon. Positioned on each side of the frame 2 is a projection 19, having an inclined face 20 and a slightly curved wall formation 21. On each of the pawls 17 and projecting therefrom, is a pin 22, so positioned on the pawls 17 that they will engage the inclined faces 20 of the projections 19 when the handle 11 and its yoke 10 is moved into position shown in Fig. 4, the said projections 19 and pins 22 coacting, as shown in Fig. 4 to release the pawls 17 from engagement with the ratchets 15.

Each of the pawls 17 is provided near their free ends with a projection 23, which is capable of engagement with the underside of the ratchet holding pawls 13, so that when the handle yoke 10 is thrown into extreme position, as shown in Fig. 5, the pins 22 on the pawls 17 ride down over the curved wall formation 21 of the projections 19, which carry the projections 23 on the pawls 17 into engagement with the under face of the ratchet holding pawls 13, thus moving said pawls 13 out of engagement with the ratchets 15, which allows the ratchets and drum 3 to be freely rotated in either direction without being held or retarded by either set of the pawls 13 or 17.

Having thus fully described the invention, what I claim as new and desire to secure by Letters Patent of the United States, is—

1. A wire stretching machine, including a
5 suitable frame, a drum journaled therein, suitable ratchet wheels rotatable with said drum, a handle including a yoke pivoted concentrically with said drum, a pair of
10 ratchet holding pawls pivoted on said frame, a pair of ratchet actuating pawls pivoted on said yoke, each of said latter pawls being provided with an extending member, extensions on said frame in the path of
15 movement of said extensions on the pawls to coact therewith, to disengage said ratchet actuating pawls from said ratchets, and means on said ratchet actuating pawls for engagement with said ratchet holding pawls
20 to move the last mentioned pawls out of engagement with said ratchets substantially as described and for the purposes set forth.
2. A wire stretching machine, including a
frame, a drum mounted therein, a ratchet on
said drum, a handle yoke concentrically piv-
25 oted with said drum, a ratchet holding pawl pivoted on the frame, a ratchet actuating pawl pivoted on the yoke, means on the frame to be engaged by the ratchet actuating
pawl to move the ratchet actuating pawl out
of engagement with the ratchet, the said
30 ratchet holding pawl being disposed in the path of movement on the ratchet actuating
pawl to be engaged thereby to be carried
out of engagement with the ratchet, substan-
35 tially as described and for the purposes set forth.

In testimony whereof, I affix my signature, in presence of two witnesses.

WALTER H. SNOW.

Witnesses:

D. W. McLEOD,

C. C. McDERMOND.

Copies of this patent may be obtained for five cents each, by addressing the "Commissioner of Patents, Washington, D. C."