

(19) **DANMARK**

(10) **DK/EP 3472407 T3**



Patent- og
Varemærkestyrelsen

(12) **Oversættelse af
europæisk patentskrift**

-
- (51) Int.Cl.: **E 04 G 17/065 (2006.01)** **F 16 B 5/10 (2006.01)** **F 16 B 21/02 (2006.01)**
- (45) Oversættelsen bekendtgjort den: **2023-01-23**
- (80) Dato for Den Europæiske Patentmyndigheds bekendtgørelse om meddelelse af patentet: **2022-10-19**
- (86) Europæisk ansøgning nr.: **17732064.5**
- (86) Europæisk indleveringsdag: **2017-06-16**
- (87) Den europæiske ansøgnings publiceringsdag: **2019-04-24**
- (86) International ansøgning nr.: **EP2017064791**
- (87) Internationalt publikationsnr.: **WO2017216355**
- (30) Prioritet: **2016-06-17 EP 16382280**
- (84) Designerede stater: **AL AT BE BG CH CY CZ DE DK EE ES FI FR GB GR HR HU IE IS IT LI LT LU LV MC MK MT NL NO PL PT RO RS SE SI SK SM TR**
- (73) Patenthaver: **Ulma C Y E, S. Coop., Paseo Otaduy 3, 20560 Oñati, Spanien**
- (72) Opfinder: **COLINO VEGA, Manuel, P^o de la Cruz Roja 3 - 5^o A, 01015 Vitoria - Gasteiz, Spanien**
- (74) Fuldmægtig i Danmark: **Dennemeyer & Associates S.A, P.O. Box 700425, DE-81304 Munich, Tyskland**
- (54) Benævnelse: **LODRET FORSKALLING**
- (56) Fremdragne publikationer:
KR-B1- 101 497 688
KR-U- 20100 006 679

DESCRIPTION

TECHNICAL FIELD

[0001] The present invention relates to a vertical formwork.

PRIOR ART

[0002] The use of vertical formworks for making vertical structures, such as walls, is known. Vertical formworks comprise formwork panels arranged facing one another and fixed to one another by means of tie rods or anchor rods. The vertical formworks comprise anchors for fixing the tie rods to said formwork panels.

[0003] An important aspect of vertical formworks is the sealing of the formwork panel with respect to the anchor and the tie rod, since if the sealing is not done suitably, when the concrete is poured between the formwork panels concrete leakage could take place. To prevent concrete leakage, vertical formworks comprise sealing means.

[0004] EP2126248A1 discloses a vertical formwork in which sealing means are arranged in the formwork panel.

[0005] In addition, EP2816175A1 discloses a vertical formwork in which the sealing means are arranged in the anchor. Said anchor is housed in a housing of the formwork panel. The part of the anchor which is supported against the formwork panel has a spherical shape and the part of the housing on which said spherical part of the anchor is supported has a complementary shape, such that sealing is achieved by means of the support between both surfaces. The sealing means are arranged inside the anchor, sealing the attachment between the tie rod and the anchor itself.

[0006] WO2008089442A2 discloses a vertical formwork in which the sealing means are arranged in the anchor. The sealing means comprise a first sealing element which is arranged in the outer part of the anchor and the purpose of which is to seal the anchor with respect to the formwork panel. The sealing means also comprise a plurality of sealing elements inside the anchor for sealing the attachment between the tie rod and the anchor itself.

[0007] KR20100006679U discloses a vertical formwork in which the sealing means are arranged in the anchor. The anchor comprises an outer holder disposed at one end of the anchor. Inside the outer holder it is disposed an inner holder, both holders defining a housing for receiving a part of a tie rod. The anchor comprises a sealing element disposed at the free end of the outer holder. The sealing of the anchor with respect to the tie rod is made by the sealing element, whereas the sealing of the anchor with respect to the formwork panel is made

by the inner holder.

[0008] Finally, KR101497688B1 discloses a vertical formwork in which the sealing means are arranged in the anchor. The anchor comprises a cone housing disposed at one end of the anchor. Inside the cone housing it is disposed a screw unit comprising a housing for receiving a part of a tie rod. A coil pushes the screw unit against the free end of the cone housing. The anchor further comprises a rubber magnet disc disposed around a first end opposite to the free end of the cone housing. The sealing of the anchor with respect to the tie rod is made by the screw unit, whereas the sealing of the anchor with respect to the formwork panel is made by the rubber magnet disc.

DISCLOSURE OF THE INVENTION

[0009] The object of the invention is to provide a vertical formwork, as defined in the claims.

[0010] The vertical formwork of the invention comprises at least two formwork panels arranged facing one another, an anchor fixed to each of said formwork panels respectively, and a tie rod fixed to each anchor of each of the formwork panels.

[0011] Each anchor comprises a housing receiving a part of the tie rod fixing the two formwork panels facing one another, the housing comprising a tubular extension. The anchor further comprises sealing means sealing the anchor with respect to the formwork panel in which it is fixed and with respect to the tie rod housed in the housing of the anchor.

[0012] The sealing means comprise a single sealing element, said sealing element being a rubber gasket. The sealing element is arranged at the end of the tubular extension of the anchor and seals both the anchor with respect to the formwork panel in which it is fixed and the anchor with respect to the tie rod housed in the housing of the anchor.

[0013] The sealing element comprises a sealing ring, said sealing ring comprising an outer wall supported against the formwork panel. The sealing element further comprises an end ring supported against the tie rod housed in the anchor, such that the anchor is sealed with respect to the tie rod.

[0014] The sealing elements are elements that tend to deteriorate with use due to the stress they withstand. The fact that the sealing means are arranged in the anchor and not in the formwork panel makes it easier to replace damaged sealing elements, since the anchors are parts which are more manageable than the formwork panels as regards size and weight.

[0015] Arranging the sealing element at one end of the anchor instead of inside same makes the sealing element more accessible, making it easier to replace it.

[0016] As a result, replacing a damaged sealing element is done in a quick and simple

manner.

[0017] Furthermore, the two required seals are established with a single sealing element, i.e., on one hand the seal between the anchor and the respective formwork panel, and on the other the seal between the anchor and the tie rod housed in the housing of the anchor itself.

[0018] These and other advantages and features of the invention will become evident in view of the drawings and the detailed description of the invention.

DESCRIPTION OF THE DRAWINGS

[0019]

Figure 1 shows a perspective view of an embodiment of the vertical formwork according to the invention.

Figure 2 shows a second perspective view of the vertical formwork of Figure 1.

Figure 3 shows a front view of the vertical formwork of Figure 1.

Figure 4 shows a section view of the vertical formwork of Figure 1.

Figure 5 shows an exploded view of the vertical formwork of Figure 1.

Figure 6 shows a perspective view of the front anchor of the vertical formwork of Figure 1.

Figure 7 shows a section view of the front anchor of Figure 6.

Figure 8 shows a perspective view of the sealing element of the front anchor of Figure 6.

Figure 9 shows a section view of the sealing element of the anchor of Figure 6.

Figure 10 shows a section view of the tubular extension of the front anchor of Figure 6.

Figure 11 shows a detailed section view of the front anchor of Figure 6 when it is fixed to the front formwork panel.

Figure 12 shows a perspective view of the rear anchor of the vertical formwork of Figure 1.

Figure 13 shows a section view of the rear anchor of Figure 12.

Figure 14 shows a perspective view of the sealing element of the rear anchor of Figure 12.

Figure 15 shows a section view of the sealing element of the rear anchor of Figure 12.

Figure 16 shows a section view of the tubular extension of the rear anchor of Figure 12.

Figure 17 shows a detailed section view of the rear anchor of Figure 12 when it is fixed to the

rear formwork panel.

Figure 18 shows a section view of a formwork panel of the vertical formwork of Figure 1.

DETAILED DISCLOSURE OF THE INVENTION

[0020] Figures 1 to 5 show an embodiment of the vertical formwork 1 according to the invention.

[0021] The vertical formwork 1 comprises two formwork panels 4 and 5 arranged facing one another, an anchor 2 and 3 fixed to each of said formwork panels 4 and 5 respectively, and a tie rod 6 fixed to the anchors 2 and 3 fixed in each of the formwork panels 4 and 5.

[0022] In this embodiment, both formwork panels 4 and 5 are identical. Each of said formwork panels 4 and 5 comprises a structure 40 and 50, a board 41 and 51 fixed to said structure 40 and 50, and a bushing 42 and 52 going through said structure 40 and 50 and said board 41 and 51. Preferably, the board 41 and 51 is made of wood and the structure 40 and 50 and the bushing 42 and 52 are made of metal. For the sake of clarity, the formwork panels 4 and 5 are only partially depicted in the drawings.

[0023] The vertical formwork 1 of this embodiment is a vertical formwork suitable for being adjusted from one face, i.e., the tie rod 6 can be fixed from one side of the formwork. In systems of this type one of the anchors, referred to as rear anchor 3, is fixed to one of the formwork panels, referred to as rear formwork panel 5, before the formwork panels 4 and 5 are positioned. Once the formwork panels 4 and 5 are positioned, the operator is on the opposite side, fixing the other anchor 2, referred to as front anchor 2, and fixing the tie rod 6 to both anchors 2 and 3. To understand this document, the front part will be considered the part where the operator fixing the tie rod 6 is located. Therefore, the formwork panel arranged on the side of the operator will be referred to as the front formwork panel 4, and the formwork panel facing said front panel 4 will be referred to as the rear formwork panel 5. Likewise, the anchor fixed to the front formwork panel 4 will be referred to as front anchor 2, and the anchor fixed to the rear formwork panel 5 will be referred to as the rear anchor 3. Furthermore, the inner face 43 and 53 of the formwork panel 4 and 5 will be considered the face suitable for being arranged in contact with the concrete and the outer face 44 and 54 of the formwork panel 4 and 5 will be considered the face opposite the inner face 43 and 53.

[0024] In this embodiment, the formwork panel 4, shown in detail in Figure 18, comprises a housing extending from the outer face 44 to the inner face 43. The bushing 42 of the formwork panel 4 is arranged in said housing. The bushing 42 forms a housing in which part of the corresponding anchor 2 is housed. The bushing 42 has an inlet opening 420 which is arranged flush with the outer face 44 of the formwork panel 4, and an outlet opening 421 which is

arranged flush with the inner face 43 of the formwork panel 4, the diameter of the outlet opening 421 being smaller than the diameter of the inlet opening 420. The configuration of the rear formwork panel 5 is the same as that of the front formwork panel 4.

[0025] In other embodiments, depending on the dimensions of the formwork panel, each formwork panel can comprise a plurality of housings, a bushing and a respective anchor being arranged in each of them, such that two facing formwork panels can be fixed to one another through a plurality of tie rods fixed to said anchors.

[0026] As discussed above, the vertical formwork 1 comprises an anchor 2 and 3 suitable for being fixed to each of the formwork panels 4 and 5. Figures 6 and 7 show the front anchor 2 in detail, whereas Figures 12 and 13 show the rear anchor 3 in detail. Each anchor 2 and 3 comprises a housing 24 and 34 suitable for receiving a part of the tie rod 6 fixing the formwork panels 4 and 5 facing one another.

[0027] Each anchor 2 and 3 also comprises sealing means configured for sealing the anchor 2 and 3 with respect to the formwork panel 4 and 5 in which it is fixed and the anchor 2 and 3 with respect to the part of the tie rod 6 housed in the housing 24 and 34 of the anchor 2 and 3. The sealing means comprise a sealing element 23 and 33 which is arranged at the end of the anchor 2 and 3 configured for being arranged in the proximity of the inner face 43 and 53 of the corresponding formwork panel 4 and 5, said sealing element 23 and 33 sealing both the anchor 2 and 3 with respect to the formwork panel 4 and 5 in which it is fixed, and the anchor 2 and 3 with respect to the part of the tie rod 6 housed in the housing 24 and 34 of the anchor 2 and 3.

[0028] The sealing means of vertical formworks are elements which tend to deteriorate with use, and for this reason it is customary to have to change them. The fact that the sealing element 23 and 33 is arranged in the anchor 2 and 3 and not in the formwork panel 4 and 5 makes it easier to replace it, since the anchors 2 and 3 are elements which are more manageable than the formwork panels 4 and 5 as regards dimensions and weight. Furthermore, deterioration due to abrasion of the sealing elements 23 and 33 is prevented when cleaning the formwork panels 4 and 5 with wire brushes to remove cement residues that may remain after using said formwork panels 4 and 5. By arranging the sealing element 23 and 33 at the end of the anchor 2 and 3 instead of inside the anchor 2 and 3, the sealing element 23 and 33 is more accessible and can therefore be replaced more easily. Furthermore, the two required seals are established with a single sealing element 23 and 33 so that there is no cement leakage.

[0029] In this embodiment, each anchor 2 and 3 comprises a respective tubular extension 22 and 32, the respective sealing element 23 and 33 being arranged at one end of said tubular extension 22 and 32. The tubular extension 22 and 32 comprises an outer fixing groove 220 and 320 which is arranged in the proximity of a first end 222 and 322 of the tubular extension 22 and 32. The sealing element 23 and 33 comprises an inner fixing ring 232 and 332 at one of its ends, said inner fixing ring 232 and 332 of the sealing element 23 and 33 being housed in

the outer fixing groove 220 and 320 of the tubular extension 22 and 32. This type of clamping for fixing the sealing element 23 and 33 to the tubular extension 22 and 32 allows assembling and disassembling the sealing element 23 and 33 without having to use special tools to that end.

[0030] Furthermore, in this embodiment to make it easier to assemble and disassemble the sealing element 23 and 33 with respect to the corresponding tubular extension 22 and 32, the inner fixing ring 232 and 332 is cone-shaped.

[0031] In this embodiment, the tubular extension 22 and 32 comprises an abutment ring 221 and 321 after the outer fixing groove 220 and 320. The sealing element 23 and 33 comprises an inner housing 233 and 333 after the inner fixing ring 232 and 332 in which the abutment ring 221 and 321 of the corresponding tubular extension 22 and 32 is housed.

[0032] Figures 8 and 9 show the sealing element 23 of the front anchor 2 in detail, whereas Figures 14 and 15 show the sealing element 33 of the rear anchor 3 in detail. Arranging the sealing element 23 and 33 in the anchor 2 and 3 instead of in the formwork panel 4 and 5 allows optimizing the design of the sealing elements 23 and 33 according to the function of each sealing element 23 and 33. In the case of arranging the sealing elements in the formwork panels, this differentiation is hindered since it is common for both the front and rear formwork panels to be identical.

[0033] In this embodiment, both sealing elements 23 and 33 comprise an outer guiding ring 234 and 334 diametrically projecting with respect to the rest of the sealing element 23 and 33 and configured for guiding the end of the anchor 2 and 3 to the outlet opening 421 and 521 of the bushing 42 and 52 of the formwork panel 4 and 5 in which it is fixed. Said outer guiding ring 234 and 334 cooperates with the inner wall of the bushing 42 and 52 such that the end of the anchor 2 and 3 is guided to the outlet opening 421 and 521 of the bushing 42 and 52. The outer guiding ring 234 and 334 thereby makes it easier for the sealing element 23 and 33 to come out of the outlet opening 421 and 521 when the anchor 2 and 3 is inserted in the bushing 42 and 52.

[0034] In this embodiment, both sealing elements 23 and 33 also comprise a sealing ring 235 and 335. The outer wall 235a and 335a of the sealing ring 235 and 335 is supported against the formwork panel 2 and 3 in which it is fixed. Specifically, in this embodiment the outer wall 235a and 335a of the sealing ring 235 and 335 is supported against the outlet opening 421 and 521 of the respective bushing 42 and 52. The anchor 2 and 3 is thereby sealed with respect to the bushing 42 and 52, i.e., the anchor 2 and 3 is thereby sealed with respect to the formwork panel 4 and 5.

[0035] As it can be seen in figures 11 and 17, the diameter of the outer wall 235a and 335a of the sealing ring 235 and 335 is substantially equal to or larger than the diameter of the outlet opening 421 and 521 of the formwork panel 4 and 5 in which the anchor is configured to be fixed such that the outer wall 235a and 335a of the sealing ring 235 and 335 is supported

against the outlet opening 421 and 521 of the respective bushing 42 and 52. This way is avoided that concrete can enter to the bushing 42 and 52 through the outlet opening 421 and 521.

[0036] In this embodiment, both sealing elements 23 and 33 also comprise an end ring 236 and 336 suitable for being supported against the tie rod 6 housed in the respective anchor 2 and 3, such that the anchor 2 and 3 is sealed with respect to the tie rod 6. The diameter of the end ring 236 and 336 is substantially equal to or smaller than the diameter of the section of the tie rod 6 where the end ring 236, 336 is supported when said end ring 236, 336 is supported against said tie rod 6. This way it is avoided that concrete can enter to the anchor 2 and 3 through its housing 24 and 34 where part of the tie rod 6 is housed.

[0037] In the case of the front anchor 2, the diameter of the tie rod 6 in contact with the end ring 236 of the sealing element 23 slightly varies depending on the width of the wall to be built, i.e., the distance left between the inner faces 43 and 53 of the formwork panels 4 and 5, since the part of the tie rod 6 in contact with the end ring 236 is cone-shaped. Therefore, the end ring 236 adapts to the variation in diameter of the tie rod 6 by sealing the front anchor 2 with respect to the tie rod 6.

[0038] Furthermore, in this embodiment when the tie rod 6 is housed in the housing 34 of the rear anchor 3, the end ring 336, due to the dimensions of the tie rod 6, tends to bend into the sealing element 33. The sealing element 33 comprises an inner gap 337 between the end ring 336 and the sealing ring 335 such that when the tie rod 6 is housed in the anchor 3, the part of the end ring 336 bent inwardly can be housed in said inner gap 337.

[0039] Preferably the sealing ring 235 and 335 is harder than the end ring 236 and 336, such that the end ring 236 and 336 is more flexible so it can be adapted better to the variation in diameter of the tie rod 6 in contact with the end ring 236 and 336.

[0040] In this embodiment, the inner wall 335b of the sealing ring 335 of the sealing element 3 of the rear anchor 3 is also supported against the tie rod 6, because the diameter of the inner wall 335b of the sealing ring 335 is substantially equal to or smaller than the diameter of the section of the tie rod 6 in contact with said inner wall 335b thereby achieving a double seal of the tie rod 6 with respect to the rear anchor 3.

[0041] In this embodiment, when the anchor 2 and 3 is fixed to the corresponding formwork panel 4 and 5, the end ring 236 and 336 projects from the bushing 42 and 52 of said formwork panel 4 and 5. Preferably, part of the sealing ring 235 and 335 also projects from the bushing 42 and 52.

[0042] In this embodiment, both sealing elements 23 and 33 comprise a first part 230 and 330 comprising the inner fixing ring 232 and 332, the outer guiding ring 234 and 334 and the sealing ring 235 and 335, and a second part 231 and 331 after the first part 230 and 330 comprising the end ring 236 and 336.

[0043] The first part 230 and 330 of both sealing elements 23 and 33 is preferably made with a material harder than the second part 231 and 331 of the sealing element 23 and 33, because since part of said first part of the sealing element 23 and 33 is supported against the bushing 42 and 52 it deteriorates more.

[0044] The sealing element 23, 33 is a rubber gasket which is made in this embodiment by injecting two materials having a different hardness. The material used for making the sealing elements 23 and 33 is preferably an elastomer.

[0045] In this embodiment, both the front anchor 2 and the rear anchor 3 comprise a dome plate 20 and 30 comprising a spherical part with an opening 200 and 300, and a body 21 and 31 which is arranged in said opening 200 and 300. The body 21 and 31 comprises a first part 210 and 310 having a support wall with a spherical shape coupled like a ball and socket joint to the spherical part of the dome plate 20 and 30, and the tubular extension 22 and 32 after said first part 210 and 310.

[0046] In this embodiment, the body 21 and 31 of the anchor comprises the housing 24 and 34 of the anchor 2 and 3. The housing 34 of the rear anchor 3 is a threaded housing and is suitable for receiving a threaded end of the tie rod 6. Therefore, the tubular extension 32 of the rear anchor 3 has a dual function, i.e., on one hand it helps fix the threaded end of the tie rod 6 to the anchor 3, and on the other it allows arranging the sealing element 33 in the proximity of the inner face 53 of the formwork panel 5. The housing 24 of the front anchor 2 is a non-threaded housing. The tubular extension 22 of the front anchor 2 has the function of arranging the sealing element 23 in the proximity of the inner face 43 of the formwork panel 4.

[0047] As discussed above, the first part 210 and 310 of the body 21 and 31 has certain play like a ball and socket joint with the spherical part of the dome plate 20 and 30 in which said body 21 and 31 is arranged. This assures that when the outlet openings 421 and 521 of the bushings 42 and 52 of the formwork panels 4 and 5 are not completely aligned, and therefore the tie rod 6 is arranged in a slanted manner, the support wall of the body 21 and 31 is supported in its entirety on the dome plate 20 and 30. Since the sealing element 23 and 33 is arranged at one end of the tubular extension 22 and 32, the other end of which is in turn fixed to the first part 210 and 310 of the body 21 and 31, it is assured that the sealing element 23 and 33 is always aligned with the tie rod 6 such that it deteriorates less than when the sealing element is arranged in the formwork panel, since in this situation if the tie rod is arranged in a slanted manner with respect to the axis of the sealing element, said sealing element deteriorates more.

[0048] In this embodiment, the dome plate 20 and 30 of each anchor 2 and 3 is fixed to the outer face 44 and 54 of the corresponding formwork panel 4 and 5. To that end, the dome plate 20 and 30 comprises a screw and a pin, whereas the structure 40 and 50 of the formwork panel 4 and 5 comprises two non-threaded holes in which said screw and said pin are housed such that the anchor 2 and 3 is fixed to the corresponding formwork panel 4 and 5.

REFERENCES CITED IN THE DESCRIPTION

Cited references

This list of references cited by the applicant is for the reader's convenience only. It does not form part of the European patent document. Even though great care has been taken in compiling the references, errors or omissions cannot be excluded and the EPO disclaims all liability in this regard.

Patent documents cited in the description

- [EP2126248A1 \[0004\]](#)
- [EP2816175A1 \[0005\]](#)
- [WO2008089442A2 \[0006\]](#)
- [KR20100006679U \[0007\]](#)
- [KR101497688B1 \[0008\]](#)

LODRET FORSKALLING**PATENTKRAV**

1. Lodret forskalling, der omfatter mindst
 - to forskallingspaneler (4, 5), der er anbragt vendt mod hinanden,
 - et anker (2, 3), der er fastgjort på hvert af forskallingspanelerne (4, 5), og
 - en stagbolt (6), der er fastgjort på hvert anker (2, 3) på hvert af forskallingspanelerne (4, 5),
 - hvor hvert anker (2, 3) omfatter
 - o et hus (24, 34), der rummer en del af stagbolten (6), der fastgør de to forskallingspaneler (4, 5), hvor huset (24, 34) omfatter en rørformet forlængelse (22, 32), og
 - o tætningsmidler, der tætnet ankeret (2, 3) i forhold til forskallingspanelet (4, 5), som det er fastgjort i, og i forhold til stagbolten (6), der er anbragt i ankerets (2, 3) hus (24, 34),

kendetegnet ved, at

- o tætningsmidlerne omfatter et enkelt tætningselement (23, 33), hvilket tætningselement (23, 33) er en gummipakning, der er anbragt på den ene ende (222, 322) af den rørformede forlængelse (22, 32) af ankeret (2, 3), og
 - o hvilket tætningselement (23, 33) både tætnet ankeret (2, 3) i forhold til forskallingspanelet (4, 5), som det er fastgjort i, og ankeret (2, 3) i forhold til stagbolten (6), der er anbragt i ankerets (2, 3) hus (24, 34),
 - o hvor tætningselementet (23, 33) omfatter en tætningsring (235, 335), hvilken tætningsring (235, 335) omfatter en udvendig væg (235a, 335a), der understøttes mod forskallingspanelet (4, 5), og
 - o hvor tætningselementet (23, 33) omfatter en endering (236, 336), der understøttes mod stagbolten (6), der er anbragt i ankeret (2, 3), således at ankeret (2, 3) tætnes i forhold til stagbolten (6).
2. Lodret forskalling ifølge krav 1, hvor diameteren af den udvendige væg (235a, 335a) på tætningsringen (235, 335) i det væsentlige svarer til eller er større end diameteren af en udgangsåbning (421, 521) i forskallingspanelet (4, 5), i hvilket ankeret (2, 3) er fastgjort.

3. Lodret forskalling ifølge krav 1 eller 2, hvor diameteren af enderingen (236, 336) i det væsentlige svarer til eller er mindre end diameteren af afsnittet af stagbolten (6), hvor enderingen (236, 336) understøttes.
4. Lodret forskalling ifølge et hvilket som helst af de foregående krav, hvor tætningsringen (235, 335) er hårdere end enderingen (236, 336).
5. Lodret forskalling ifølge et hvilket som helst af de foregående krav, hvor den rørformede forlængelse (22, 32) omfatter en udvendig fastgørelsesrille (220, 320), der er anbragt i nærheden af enden (222, 322) af den rørformede forlængelse (22, 32), og tætningselementet (23, 33) omfatter en indvendig fastgørelsesring (232, 332) ved den ene af sine ender, hvor den indvendige fastgørelsesring (232, 332) i tætningselementet (23, 33) er anbragt i den udvendige fastgørelsesrille (220, 320) i den rørformede forlængelse (22, 32).
6. Lodret forskalling ifølge et hvilket som helst af de foregående krav, hvor tætningselementet (23, 33) omfatter en udvendig styrering (234, 334), der rager diametralt frem i forhold til resten af tætningselementet (23, 33) og er udformet til at lede hvert anker (2, 3) hen til udgangsåbningen (421) i forskallingspanelet (4, 5), som det fastgøres i.
7. Lodret forskalling ifølge et hvilket som helst af de foregående krav, hvor en indvendig væg på tætningsringen (335) er understøttet mod stagbolten (6).
8. Lodret forskalling ifølge krav 1, hvor tætningselementet (23, 33) omfatter
 - en første del (230, 330), der omfatter
 - en indvendig fastgørelsesring (232, 332), der er anbragt i en udvendig fastgørelsesrille (220, 320) i den rørformede forlængelse (22, 32),
 - en udvendig styrering (234, 334), der rager diametralt frem i forhold til resten af tætningselementet (23, 33) og er udformet til at lede ankeret (2, 3) hen til udgangsåbningen (421) i forskallingspanelet (4, 5), som det fastgøres i, og
 - tætningsringen (235, 335) og
 - en anden del (231, 331) efter den første del (230, 330), der omfatter
 - enderingen (236, 336),

- hvor den første del (230, 330) af tætningselementet (23, 33) er hårdere end den anden del (231, 331) af tætningselementet (23, 33).
9. Lodret forskalling ifølge krav 8, hvor tætningselementet (23, 33) fremstilles ved at injicere to materialer med forskellig hårdhed.
 10. Lodret forskalling ifølge et hvilket som helst af de foregående krav, der omfatter en kuppelplade (20, 30), der omfatter en sfærisk del med en åbning (200, 300) og et legeme (21, 31), der er anbragt i åbningen (200, 300), hvor legemet (21, 31) omfatter en første del (210, 310), der er forbundet med kuppelpladen (200, 300) i lighed med et kugleled, og enden, ved hvilken tætningselementet (23, 33) anbringes efter den første del (210, 310).
 11. Lodret forskalling ifølge et hvilket som helst af de foregående krav, hvor en del af tætningselementet (23, 33) rager frem fra det respektive forskallingspanel (4, 5).

DRAWINGS

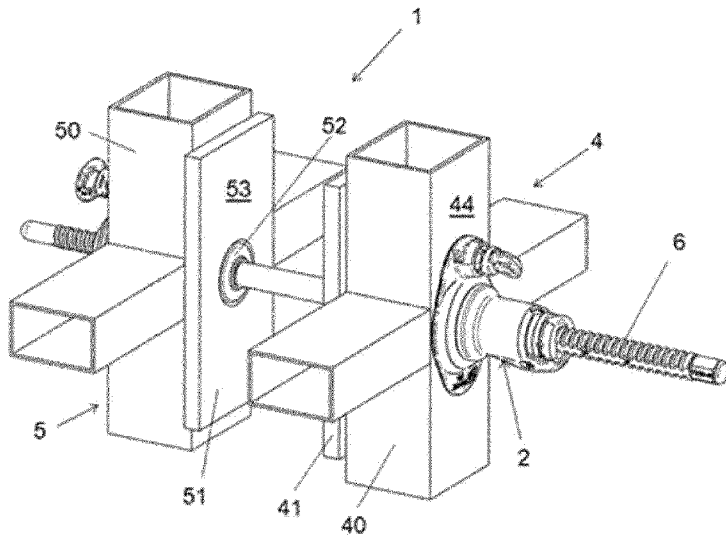

FIG. 1

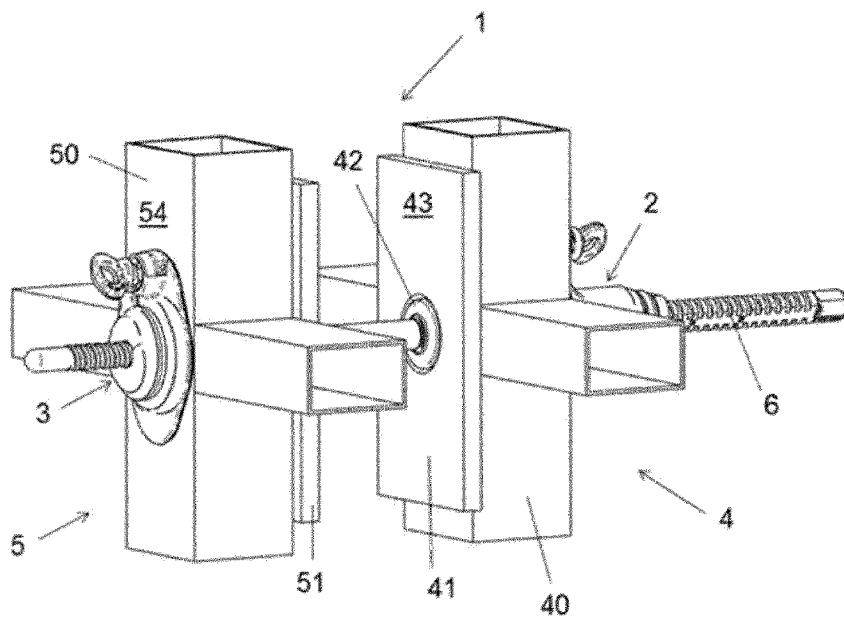
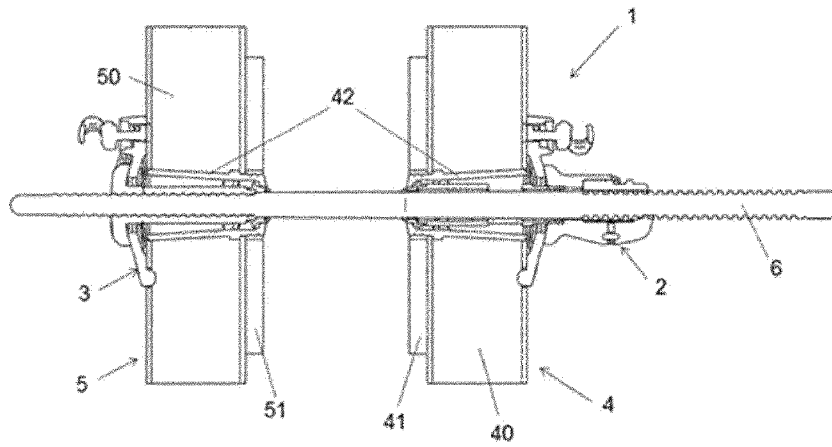
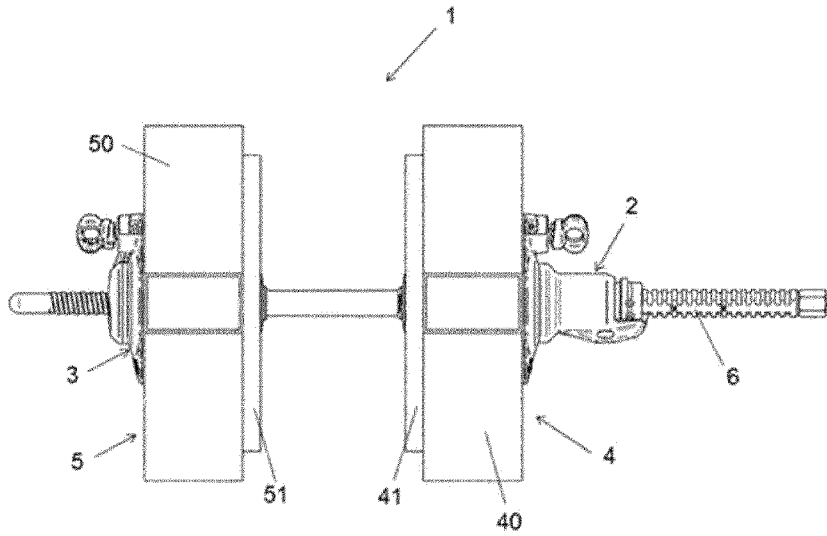

FIG. 2



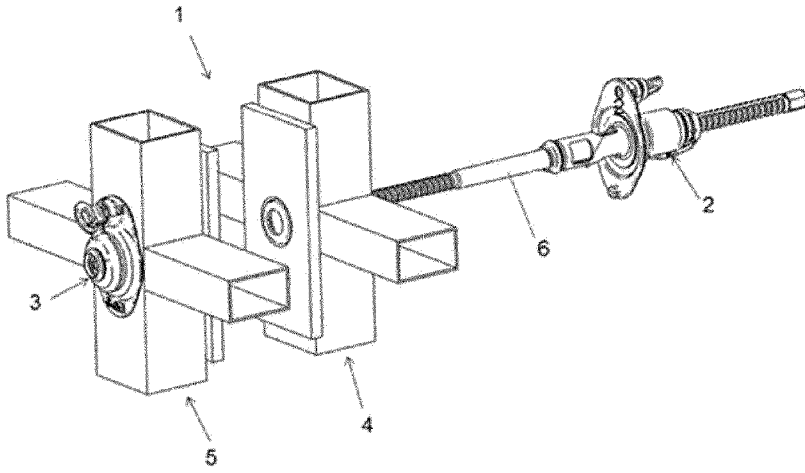

FIG.5

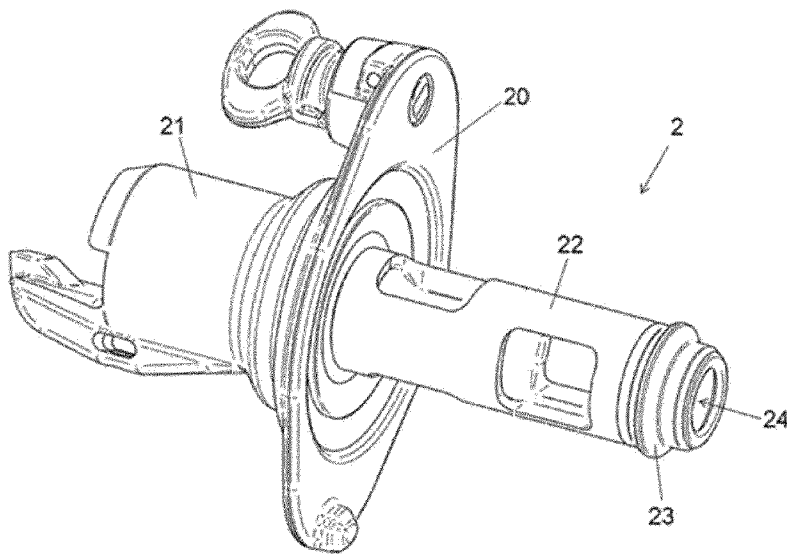

FIG.6

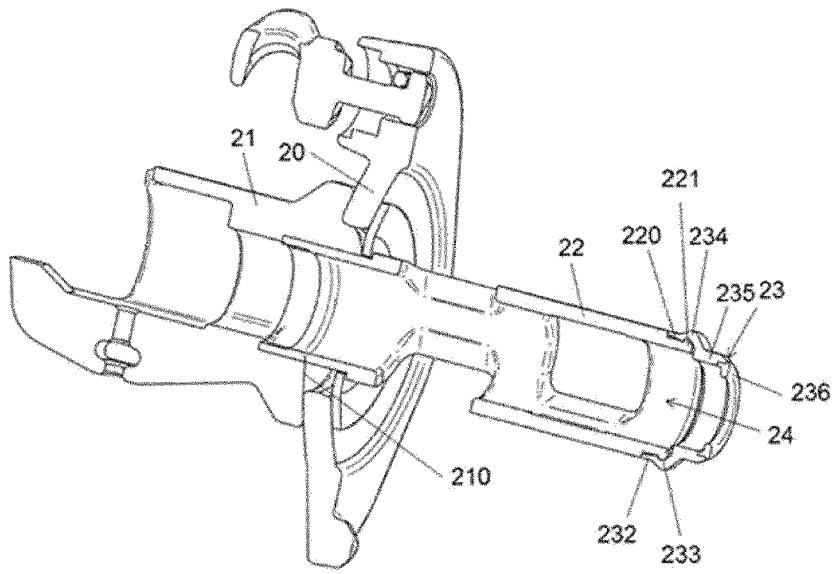

FIG. 7

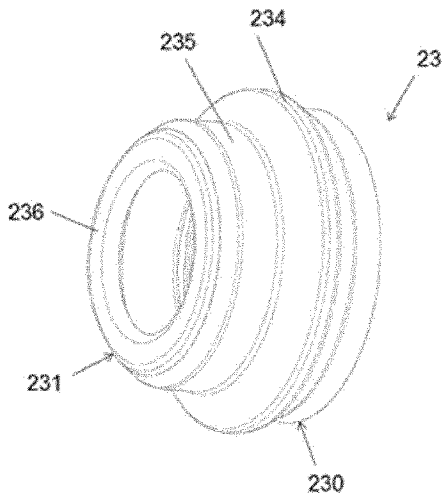

FIG. 8

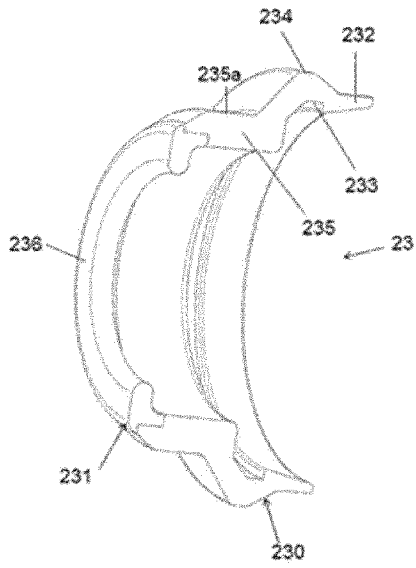

FIG. 9

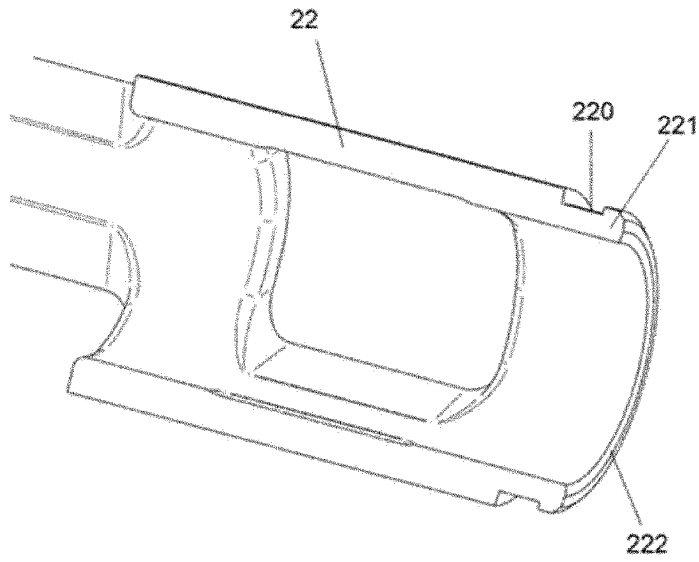

FIG. 10

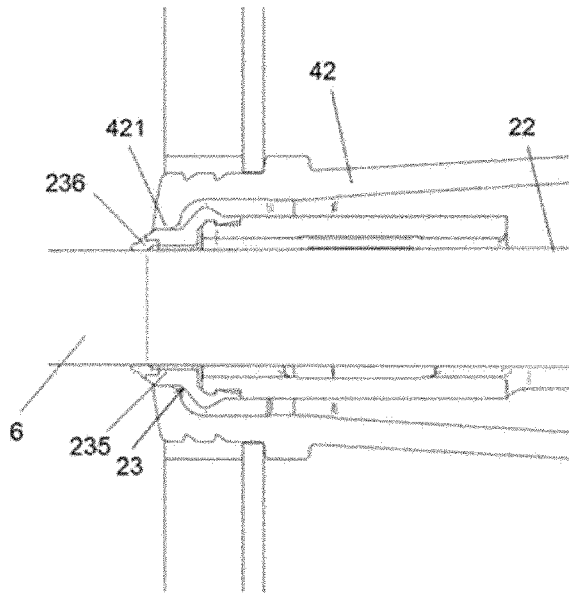

FIG. 11

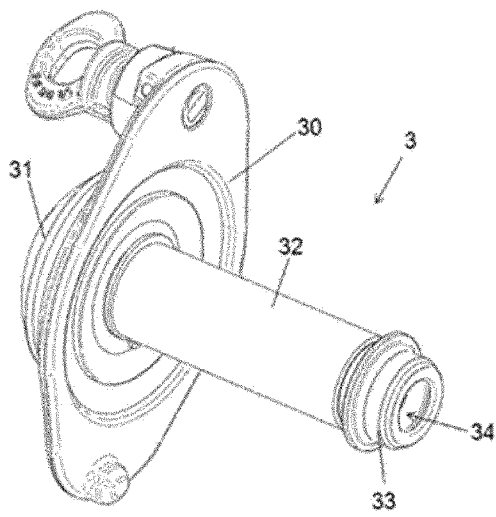

FIG. 12

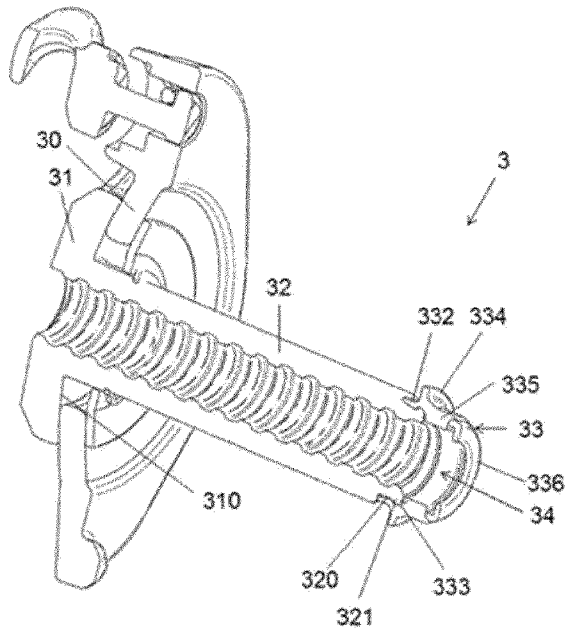

FIG. 13

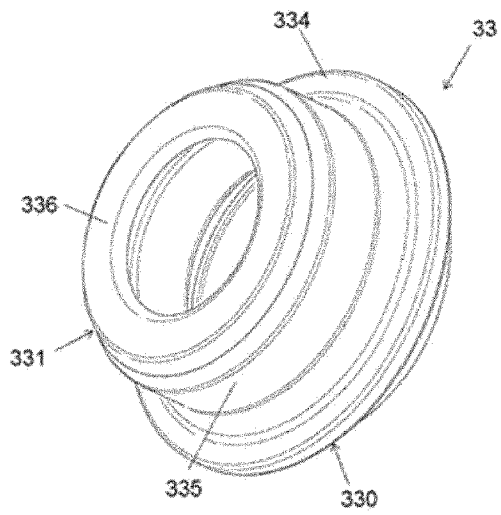
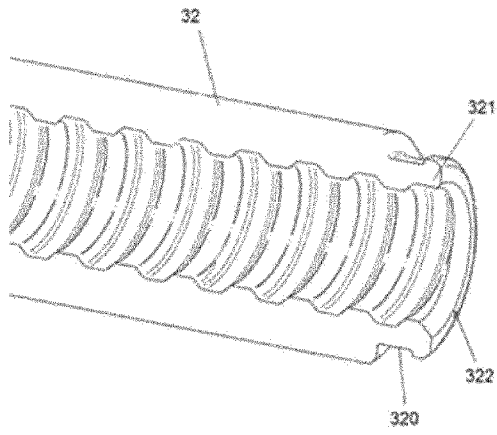
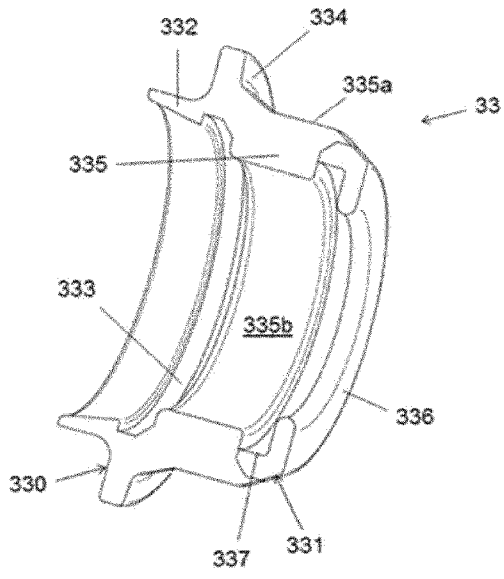

FIG. 14



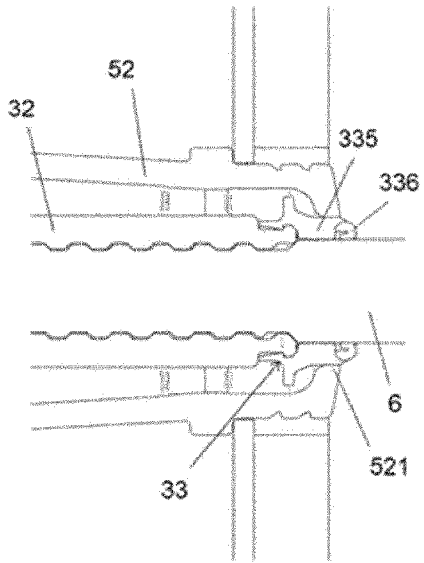

FIG. 17

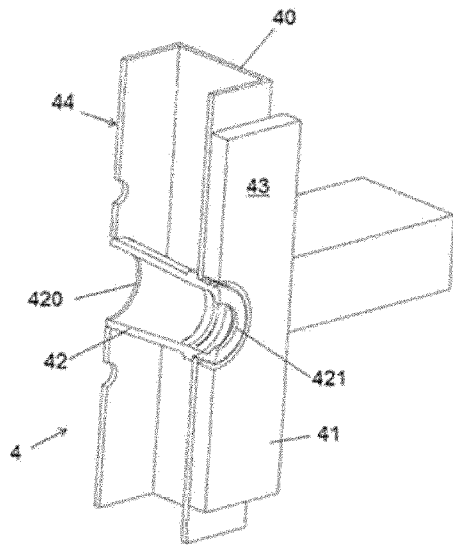

FIG. 18