



- (51) International Patent Classification:
G10L 19/008 (2013.01) *G06F 3/01* (2006.01)
H04S 7/00 (2006.01) *G10L 21/0272* (2013.01)
- (21) International Application Number:
 PCT/EP2018/069140
- (22) International Filing Date:
 13 July 2018 (13.07.2018)
- (25) Filing Language: English
- (26) Publication Language: English
- (30) Priority Data:
 17181488.2 14 July 2017 (14.07.2017) EP
- (71) Applicants: **FRAUNHOFER-GESELLSCHAFT ZUR FÖRDERUNG DER ANGEWANDTEN FORSCHUNG E.V.** [DE/DE]; Hansastraße 27c, 80686 München (DE). **FRIEDRICH-ALEXANDER-UNIVERSITÄT**

- ERLANGEN-NUERNBERG** [DE/DE]; Schlossplatz 4, 91054 Erlangen (DE).
- (72) Inventors: **HERRE, Jürgen**; Rathsberger Str. 10a, 91054 Erlangen (DE). **HABETS, Emanuel**; Schwedenstraße 13, 91080 Spardorf (DE).
- (74) Agent: **ZINKLER, Franz** et al.; Schoppe, Zimmermann, Stöckeler, Zinkler, Schenk & Partner mbB, Radlkofenstr. 2, 81373 München (DE).
- (81) Designated States (unless otherwise indicated, for every kind of national protection available): AE, AG, AL, AM, AO, AT, AU, AZ, BA, BB, BG, BH, BN, BR, BW, BY, BZ, CA, CH, CL, CN, CO, CR, CU, CZ, DE, DJ, DK, DM, DO, DZ, EC, EE, EG, ES, FI, GB, GD, GE, GH, GM, GT, HN, HR, HU, ID, IL, IN, IR, IS, JO, JP, KE, KG, KH, KN, KP, KR, KW, KZ, LA, LC, LK, LR, LS, LU, LY, MA, MD, ME, MG, MK, MN, MW, MX, MY, MZ, NA, NG, NI, NO, NZ, OM, PA, PE, PG, PH, PL, PT, QA, RO, RS, RU, RW, SA,

(54) Title: CONCEPT FOR GENERATING AN ENHANCED SOUND FIELD DESCRIPTION OR A MODIFIED SOUND FIELD DESCRIPTION USING A MULTI-POINT SOUND FIELD DESCRIPTION

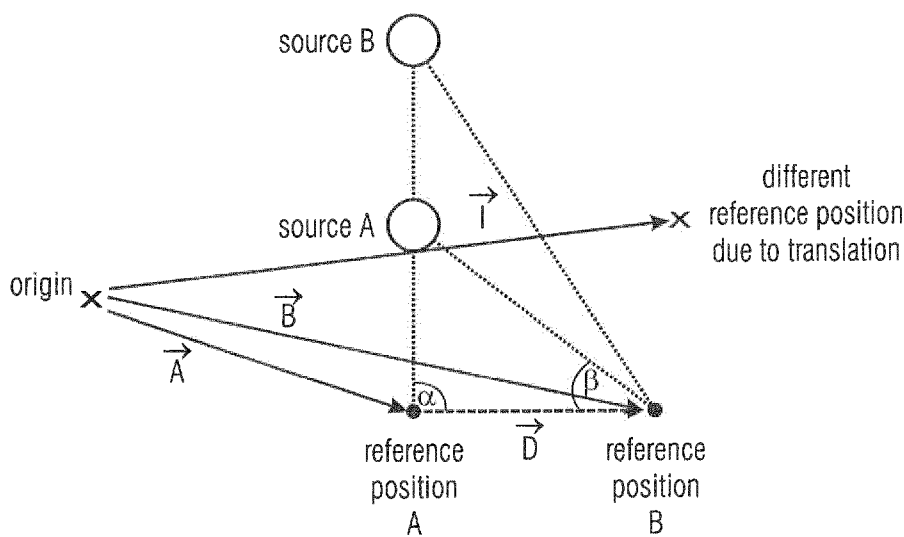

Fig. 4c

(57) Abstract: Apparatus for generating an enhanced sound field description, comprising: a sound field generator (100, 250, 260) for generating at least one sound field description indicating a sound field with respect to at least one reference location; and a meta data generator (110) for generating meta data relating to spatial information of the sound field, wherein the at least one sound field description and the meta data constitute the enhanced sound field description. The at least one sound field description comprises in a certain case a first sound field description related to the at least one reference location and a second sound field description related to a further reference location being different from the reference location, and the meta data relating to the spatial information indicates the reference location and the further reference location or one of both reference locations and a vector extending between both reference locations.



SC, SD, SE, SG, SK, SL, SM, ST, SV, SY, TH, TJ, TM, TN,
TR, TT, TZ, UA, UG, US, UZ, VC, VN, ZA, ZM, ZW.

(84) Designated States (*unless otherwise indicated, for every kind of regional protection available*): ARIPO (BW, GH, GM, KE, LR, LS, MW, MZ, NA, RW, SD, SL, ST, SZ, TZ, UG, ZM, ZW), Eurasian (AM, AZ, BY, KG, KZ, RU, TJ, TM), European (AL, AT, BE, BG, CH, CY, CZ, DE, DK, EE, ES, FI, FR, GB, GR, HR, HU, IE, IS, IT, LT, LU, LV, MC, MK, MT, NL, NO, PL, PT, RO, RS, SE, SI, SK, SM, TR), OAPI (BF, BJ, CF, CG, CI, CM, GA, GN, GQ, GW, KM, ML, MR, NE, SN, TD, TG).

Published:

— *with international search report (Art. 21(3))*

Concept for Generating an Enhanced Sound field Description or a Modified Sound field Description using a Multi-Point Sound field Description

5

Specification

The present invention is related to audio processing and, particularly, audio processing in relation to sound fields that are defined with respect to a reference location such as a microphone or a virtual microphone location.

Ambisonics signals comprise a truncated spherical harmonic decomposition of the sound field. Ambisonics comes in different flavors. There is 'traditional' Ambisonics [31] which today is known as 'First-Order Ambisonics' (FOA) and comprises four signals (i.e., one omnidirectional signal and up to three figure-of-eight directional signals). More recent Ambisonics variants are known as 'Higher-Order Ambisonics' (HOA) and provide enhanced spatial resolution and larger listener sweet-spot area at the expense of carrying more signals. In general, a fully defined N-th order HOA representation consists of $(N+1)^2$ signals.

20

Related to the Ambisonics idea, the Directional Audio Coding (DirAC) representation has been conceived to represent a FOA or HOA sound scene in a more compact, parametric style. More specifically, the spatial sound scene is represented by one (or more) transmitted audio channels which represent a downmix of the acoustic scene and associated side information of the direction and diffuseness in each time-frequency (TF) bin. More information on DirAC can be found in [32, 33].

25

DirAC [32] can be used with different microphone systems and with arbitrary loudspeaker setups. The purpose of the DirAC system is to reproduce the spatial impression of an existing acoustical environment as precisely as possible using a multichannel / 3D loudspeaker system. Within the chosen environment, responses (continuous sound or impulse responses) are measured with an omnidirectional microphone (W) and with a set of microphones that enables to measure the direction-of-arrival of sound and the diffuseness of sound. A common method is to apply three figure-of-eight microphones (X,Y,Z) aligned with the corresponding Cartesian coordinate axes [34]. A way to do this is to use a Sound field microphone, which directly yields all the desired responses. The W,

30
35

X, Y, and Z signals can also be computed from a set of discrete omnidirectional microphones.

In DirAC, the sound signal is first divided into frequency channels. The sound direction and diffuseness is measured depending on time at each frequency channel. In transmission, one or more audio channels are sent, together with analyzed direction and diffuseness data. In synthesis, the audio which is applied to the loudspeakers can be for example the omnidirectional channel W, or the sound for each loudspeaker can be computed as a weighed sum of W, X, Y, and Z, which forms a signal which has a certain directional characteristics for each loudspeaker. Each audio channel is divided into frequency channels, which are then divided optionally to diffuse and to non-diffuse streams depending on analyzed diffuseness. A diffuse stream is reproduced with a technique, which produces a diffuse perception of a sound scene, e.g., the decorrelation techniques used in Binaural Cue Coding [35-37]. Non-diffuse sound is reproduced with a technique which aims to produce a point-like virtual source according to the direction data (e.g. VBAP [38]).

Three techniques for navigation in 6DoF with a limited degree-of-freedom are proposed in [39]. Given a single Ambisonics signal, a single Ambisonics signal is computed using: 1) simulating HOA playback and listener movement within a virtual loudspeaker array, 2) computing and translating along plane-waves, and 3) re-expanding the sound field about the listener.

Furthermore, reference is made to the DirAC technology as described, for example, in the publication "Directional Audio Coding – Perception-Based Reproduction of Spatial Sound", V. Pulkki et al, International Workshop on the Principles and Applications of Spatial Hearing, November 11-13, 2009, Zao, Miyagi, Japan. This reference describes directional audio coding as an example for a reference location related sound field processing particularly as a perceptually motivated technique for spatial audio processing. It has applications in capturing, coding and re-synthesis of spatial sound, in teleconferencing, in directional filtering, and in virtual auditory environments.

Reproduction of sound scenes has often been focusing on loudspeaker setups, as this was the typical reproduction in private, e.g., living room, and professional context, i.e., cinemas. Here, the relation of the scene to the reproduction geometry is static as it accompanies a two-dimensional image that forces the listener to look in the front direction.

Subsequently, the spatial relation of the sound and visual objects is defined and fixed at production time.

In virtual reality (VR), the immersion is explicitly achieved by allowing the user to move
5 freely in the scene. Therefore, it is necessary to track the user's movement and adjust the
visual and auditory reproduction to the user's position. Typically, the user is wearing a
head-mounted display (HMD) and headphones. For an immersive experience with
headphones, the audio has to be binauralized. Binauralization is a simulation of how the
10 human head, ears, and upper torso change the sound of a source depending on its
direction and distance. This is achieved by convolution of the signals with head-related
transfer functions (HRTFs) for their relative direction [1, 2]. Binauralization also makes the
sound appear to be coming from the scene rather than from inside the head [3]. A
common scenario that has already been addressed successfully is 360° video
15 reproduction [4, 5]. Here, the user is either wearing an HMD or holding a tablet or phone
in his hands. By moving her/his head or the de-vice, the user can look around in any
direction. This is a three-degrees-of-freedom (3DoF) scenario, as the user has three
movement degrees (pitch, yaw, roll). Visually, this is realized by projecting the video on a
sphere around the user. Audio is often recorded with a spatial microphone [6], e.g., first-
20 order Ambisonics (FOA), close to the video camera. In the Ambisonics domain, the user's
head rotation is adapted in a straightforward manner [7]. The audio is then for example
rendered to virtual loudspeakers placed around the user. These virtual loudspeaker
signals are then binauralized.

Modern VR applications allow for six-degrees-of-freedom (6DoF). Additionally to the head
25 rotation, the user can move around resulting in translation of her/his position in three
spatial dimensions. The 6DoF reproduction is limited by the overall size of the walking
area. In many cases, this area is rather small, e.g., a conventional living room. 6DoF is
commonly encountered in VR games. Here, the whole scene is synthetic with computer-
generated imagery (CGI). The audio is often generated using object-based rendering
30 where each audio object is rendered with distance-dependent gain and relative direction
from the user based on the tracking data. Realism can be enhanced by artificial
reverberation and diffraction [8, 9, 10].

Regarding recorded content, there are some distinct challenges for convincing audio-
35 visual 6DoF reproduction. An early example of spatial sound manipulation in the spatial
translation domain is that of 'acoustic zoom' techniques [11, 12]. Here, the listener

position is virtually moved into the recorded visual scene, similar to zooming into an image. The user chooses one direction or image portion and can then listen to this from a translated point. This entails that all the direction of arrivals (DoAs) are changing relative to the original, non-zoomed reproduction.

5

Methods for 6DoF reproduction of recorded content have been using spatially distributed recording positions have been proposed. For video, arrays of cameras can be employed to generate light-field rendering [13]. For audio, a similar setup employs distributed microphone arrays or Ambisonics microphones. It has been shown that it is possible to generate the signal of a 'virtual microphone' placed at an arbitrary position from such recordings [14].

In order to realize such spatial sound modifications in a technically convenient way, parametric sound processing or coding techniques can be employed (cf. [15] for an overview). Directional audio coding (DirAC) [16] is a popular method to transform the recording into a representation that consists of an audio spectrum and parametric side information on the sound direction and diffuseness. It is used for acoustic zoom [11] and virtual microphone [14] applications.

The method proposed here enables 6DoF reproduction from the recording of a single FOA microphone. Recordings from a single spatial position have been used for 3DoF reproduction or acoustic zoom. But, to the inventors' knowledge, no method for interactive, fully 6DoF reproduction from such data has been proposed so far. One realizes the 6DoF reproduction by integrating information about the distance of the sound sources in the recording. This distance information is incorporated into the parametric representation of DirAC, such that the changed perspective of the listener is correctly mapped.

None of the Ambisonics sound field representations (be it as regular FOA or HOA Ambisonics or as DirAC-style parametric sound field representation) provide sufficient information to allow a translational shift of the listener's position as it is required for 6DoF applications since neither object distance nor absolute object positions in the sound scene are determined in these formats. It should be noted that the shift in the listener's position can be translated into an equivalent shift of the sound scene in the opposite direction.

35

A typical problem when moving in 6DoF is illustrated in Fig. 1b. Let us assume that the sound scene is described at Position A using Ambisonics. In this case sounds from Source A and Source B arrive from the same direction, i.e., they have the same direction-of-arrival (DOA). In case one moves to Position B the DOA of Source A and Source B are different. Using a standard Ambisonics description of the sound field, i.e., without additional information, it is not possible to compute the Ambisonics signals at Position B given the Ambisonics signals at Position A.

It is an object of the present invention to provide an enhanced sound field description on the one hand or a generation of a modified sound field description on the other hand that allow an improved or flexible or efficient processing.

This object is achieved by an apparatus for generating an enhanced sound field description of claim 1, an apparatus for generating a modified sound field description of claim 8, a method of generating an enhanced sound field description of claim 46, a method of generating a modified sound field description of claim 47, a computer program of claim 48 or an enhanced sound field description of claim 49.

The present invention is based on the finding that typical sound field descriptions that are related to a reference location need additional information so that these sound field descriptions can be processed so that a modified sound field description that is not related to the original reference location but to another reference location can be calculated. To this end, meta data relating to spatial information of this sound field is generated and the meta data together with the sound field description corresponds to the enhanced sound field description that can, for example, be transmitted or stored. In order to generate a modified sound field description from the sound field description and the meta data and, specifically, the meta data relating to spatial information of the sound field description, the modified sound field is calculated using this spatial information, the sound field description and a translation information indicating a translation from a reference location to a different reference location. Thus, the enhanced sound field description consisting of a sound field description and meta data relating to spatial information of this sound field underlying the sound field description is processed to obtain a modified sound field description that is related to a different reference location defined by additional translation information that can, for example, be provided or used at a decoder-side.

However, the present invention is not only related to an encoder/decoder scenario, but can also be applied in an application where both, the generation of the enhanced sound field description and the generation of the modified sound field description take place on basically one and the same location. The modified sound field description may, for example, be a description of the modified sound field itself or actually the modified sound field in channel signals, binaural signals or, once again, a reference location-related sound field that, however, is now related to the new or different reference location rather than the original reference location. Such an application would, for example, be in a virtual reality scenario where a sound field description together with a meta data exists and where a listener moves out from the reference location to which the sound field is given and moves to a different reference location and where, then, the sound field for the listener moving around in the virtual area is calculated to correspond to the sound field but now at the different reference location where the user has moved to.

In a particular embodiment, the enhanced sound field description has a first sound field description related the (first) reference location and a second sound field description related to a further (the second) reference location which is different from the (first) reference location, and the metadata has information on the reference location and the further reference location such as vectors pointing from a predetermined origin to these reference locations. Alternatively, the metadata can be a single vector pointing to either the reference location or the further reference location and a vector extending between the two reference locations, to which the two different sound field descriptions are related to.

The sound field descriptions can be non-parametric sound field descriptions such as first-order Ambisonics or higher-order Ambisonics descriptions. Alternatively or additionally, the sound field descriptions can be DirAC descriptions or other parametric sound field descriptions, or one sound field description can, for example, be a parametric sound field description and the other sound field description can be, for example, a non-parametric sound field description.

Hence, the sound field description may generate, for each sound field description, a DirAC description of the sound field having one or more downmix signals and individual direction data and optionally diffuseness data for different time-frequency bins. In this context, the metadata generator is configured to generate geometrical metadata for both sound field descriptions so that the reference location and the additional reference location can be

identified from the metadata. Then, it will be possible to extract individual sources from both sound field descriptions and to perform an additional processing for the purpose of generating an enhanced or modified sound field description.

5 Ambisonics has become one of the most commonly used formats for 3D audio in the context of virtual, augmented, and mixed reality applications. A wide variety of audio acquisition and production tools have been developed that generate an output signal in Ambisonics format. To present Ambisonics coded content in interactive virtual reality (VR) applications, the Ambisonics format is converted to a binaural signal or channels for
10 reproduction. In the aforementioned applications, the listener is usually able to interactively change his/her orientation in the presented scene to the extent that he/she can rotate his/her head in the sound scene enabling three-degrees-of-freedom (3DoF, i.e., pitch, yaw, and roll) and still experience an appropriate sound quality. This is implemented by rotating the sound scene before rendering according to the head
15 orientation, which can be implemented with low computational complexity and is an advantage of the Ambisonics representation. In emerging applications, such as VR, it is however desired to allow the user free movement in the sound scene rather than only changes of orientation (so-called 'six-degrees-of-freedom' or 6DoF). As a consequence, signal processing is required to change the perspective of the sound scene (i.e. to virtually
20 move within the sound scene along the x-, y-, or z-axes). However, a major disadvantage of Ambisonics is that the procedure describes the sound field from a single perspective in the sound scene. Specifically, it does not contain information about the actual location of sound sources in the sound scene which would allow to shift the sound scene ('translation') as it is required for 6DoF. This invention description provides several
25 extensions of Ambisonics to overcome this problem and facilitate also the translation, and hence enable true 6DoF.

First-order Ambisonics (FOA) recordings can be processed and reproduced over headphones. They can be rotated to account for the listener's head orientation. However,
30 virtual reality (VR) systems allow the listener to move in six-degrees-of-freedom (6DoF), i.e., three rotational plus three translational degrees of freedom. Here, the apparent angles and distances of the sound sources depend on the listener's position. A technique to facilitate 6DoF is described. In particular, a FOA recording is described using a parametric model, which is modified based on the listener's position and information about the
35 distances to the sources. The method is evaluated by a listening test, comparing different binaural renderings of a synthetic sound scene in which the listener can move freely.

In further preferred embodiments, the enhanced sound field description is output by an output interface for generating an output signal for transmission or storage, where the output signal comprises, for a time frame, one or more audio signals derived from the sound field and the spatial information for the time frame. Particularly, the sound field generator is in further embodiments adaptive to derive direction data from the sound field, the direction data referring to a direction of arrival of sound for a time period or a frequency bin and the meta data generator is configured to derive the spatial information as data items associating a distance information to the direction data.

10

Particularly, in such an embodiment, an output interface is configured to generate the output signals so that the data items for the time frame are linked to the direction data for the different frequency bins.

15

In a further embodiment, the sound field generator is also configured to generate a diffuseness information for a plurality of frequency bins of a time frame of the sound field, wherein the meta data generator is configured to only generate a distance information for a frequency bin being different from a predetermined value, or being different from infinity or to generate a distance value for the frequency bin at all, when the diffuseness value is lower than a predetermined or adaptive threshold. Thus, for time/frequency bins that have a high diffuseness, any distance value is not generated at all or a predetermined distance value is generated that is interpreted by a decoder in a certain way. Thus, it is made sure that for time/frequency bins having a high diffuseness, any distance-related rendering is not performed, since a high diffuseness indicates that, for such a time/frequency bin, the sound does not come from a certain localized source but comes from any direction and, therefore, is the same irrespective of whether the sound field is perceived at the original reference location or the different or new reference location.

20

25

30

With respect to the sound field calculator, preferred embodiments comprise a translation interface for providing the translation information or rotation information indicating a rotation of an intended listener to the modified sound field, a meta data supplier for supplying the meta data to the sound field calculator and a sound field supplier for supplying the sound field description to the sound field calculator and, additionally, an output interface for outputting the modified sound field comprising the modified sound field description and modified meta data, the modified meta data being derived from the meta data using the translation information, or the output interface outputs a plurality of loudspeaker channels, each loudspeaker channel being related a predefined loudspeaker

35

position, or the output interface outputs a binaural representation of the modified sound field.

5 In an embodiment, the sound field description comprises a plurality of sound field components. The plurality of sound field components comprise an omnidirectional component and at least one directional component. Such a sound field description is, for example, a first-order Ambisonics sound field description having an omnidirectional component and three directional components X, Y, Z or such a sound field is a higher-order Ambisonics description comprising the omnidirectional component, the three
10 directional components with respect to the X, Y, and Z directions and, additionally, further directional components that relate to other directions than the X, Y, Z directions.

In an embodiment, the apparatus comprises an analyzer for analyzing the sound field components to derive, for different time or frequency bins, direction of arrival information.
15 The apparatus additionally has a translation transformer for calculating modified DoA information per frequency or time bin using the DoA information and the meta data, where the meta data relate to a depth map associating a distance to a source included in both sound field descriptions as obtained by for example triangulation processing using two angles with respect to two different reference locations and the distance/positions or the
20 reference locations. This may apply to a fullband representation or to different frequency bins of a time frame.

Furthermore, the sound field calculator has a distance compensator for calculating the modified sound field using a distance compensation information depending from the
25 distance calculated using the meta data being the same for each frequency or time bin of a source of being different for each or some of the time/frequency bins, and from a new distance associated with the time or frequency bin, the new distance being related to the modified DoA information.

30 In an embodiment, the sound field calculator calculates a first vector pointing from the reference location to a sound source obtained by an analysis of the sound field. Furthermore, the sound field calculator calculates a second vector pointing from the different reference location to the sound source and this calculation is done using the first vector and the translation information, where the translation information defines a
35 translation vector from the reference location to the different reference location. And, then, a distance from the different reference location to the sound source is calculated using the second vector.

Furthermore, the sound field calculator is configured to receive, in addition to the translation information, a rotation information indicating a rotation of the listener's head in one of the three rotation directions given by pitch, yaw and roll. The sound field calculator is then configured to perform the rotation transformation to rotate a modified direction of arrival data for a sound field using the rotation information, where the modified direction of arrival data is derived from a direction of arrival data obtained by a sound analysis of the sound field description and the translation information.

In an embodiment, the sound field calculator is configured to determine source signals from the sound field description and directions of the source signals related to the reference location by a sound analysis.

Then, new directions of the sound sources are calculated that are related to the different reference location and this is done using the meta data, and then distance information of the sound sources related to the different reference location is calculated and, then, the modified sound field is synthesized using the distance information and the new directions of the sound sources.

In an embodiment, a sound field synthesis is performed by panning the sound source signals to a direction given by the new direction information in relation to a reproduction setup, and a scaling of the sound source signals is done using the distance information before performing the panning operation or subsequent to performing the panning operation.

In a further embodiment, a diffuse part of the sound source signal is added to a direct part of the sound source signal, the direct part being modified by the distance information before being added to the diffuse part.

Particularly, it is preferred to perform the sound source synthesis in a spectral representation where the new direction information is calculated for each frequency bin, where the distance information is calculated for each frequency bin, and where a direct synthesis for each frequency bin using the audio signal for the frequency bin is performed using an audio signal for the frequency bin, a panning gain for the frequency bin derived from the new direction information and a scaling factor for the frequency bin derived from the distance information for the frequency bin is performed.

Furthermore, a diffuse synthesis is performed using a diffuse audio signal derived from the audio signal from the frequency bin and using a diffuseness parameter derived by the

signal analysis for the frequency bin and, then, the direct signal and the diffuse signal are combined to obtain a synthesized audio signal for the time or frequency bin and, then, a frequency-time conversion is performed using audio signals for other time/frequency bins to obtain a time domain synthesized audio signal as the modified sound field.

5

Therefore, in general, the sound field calculator is configured to synthesize, for each sound source, a sound field related to the different reference location by, for example, processing, for each source, a source signal using the new direction for the source signal to obtain a sound field description of the source signal related to the different/new reference location. Furthermore, the source signal is modified before processing the source signal or subsequent to processing the source signal using the direction information. And, finally, the sound field descriptions for the sources are added together to obtain the modified sound field related to the different reference location.

10

15

In further embodiments, and, particularly, for generating a modified sound field description from the sound field description and metadata relating to spatial information of the sound field description, the sound field calculator calculates the modified sound field using the spatial information on the first sound field description, using the spatial information on the second sound field description, and using the translation information indicating a translation of a reference location to a different reference location. Particularly, the metadata may, for example, be a vector directed to the reference location of the sound field description and another vector directed from the same origin to the further reference location of the second sound field description.

20

25

In order to address a translation information, objects are generated by applying a source separation, or beamforming, or, generally, any kind of sound source analysis to the first and the second sound field description. Then, the direction of arrival information of all objects irrespective of whether these objects are broadband objects or objects for individual time/frequency bins are computed. Then, the objects extracted from the different sound field descriptions are matched with each other in order to find at least one matched object, i.e., an object occurring both in the first and the second sound field descriptions. This matching is performed, for example, by means of a correlation or coherence calculation using the object signals and/or direction of arrival information or other information.

30

35

Thus, the result of the procedure is that there does exist, for a matched object, a first DoA information related to the reference location and the second DoA information related to

the further reference location. Then, the positions of the matched objects and, particularly, the distance of the matched object to the reference location or the further reference location is calculated based on triangulation using the information on the reference location or the reference location included in the associated metadata.

5

This information, and, particularly, the position information for the matched object is then used for modifying each matched object based on the estimated position and the desired position, i.e., after translation, using a distance compensation processing. In order to calculate the new DoA information for the new listener position, the old DoA information from both reference locations and the translation information is used. Basically, this processing can be performed for both individual sound field descriptions, since each matched object occurs in both sound field descriptions. However, in accordance with preferred embodiments, the sound field description having a reference location being closest to the new listener position subsequent to the translation is used.

10
15

Then, the new DoA is used for calculating a new sound field description for the matched object related to the different reference location, i.e., to which the user has moved. Then, and in order to also incorporate the non-matched objects, sound field descriptions for those objects are calculated as well but using the old DoA information. And, finally, the modified sound field is generated by adding all individual sound field descriptions together.

20

Any change with orientation can be realized by applying a single rotation to the virtual Ambisonics signal.

25

Thus, the metadata is not used for directly providing the distance of an object to a reference location. Instead, the metadata is provided for identifying the reference location of each of two or more sound field descriptions and the distance between a reference location and a certain matched object is calculated based on, for example, triangulation processing steps.

30

Preferred embodiments of the present invention are subsequently discussed with respect to the accompanying drawings, in which:

35 Fig. 1a is a preferred embodiment of an apparatus for generating an enhanced sound field description;

- Fig. 1b is an illustration explaining an exemplary problem underlying the present invention;
- 5 Fig. 2 is a preferred implementation of the apparatus for generating an enhanced sound field description;
- Fig. 3a illustrates the enhanced sound field description comprising audio data, and side information for audio data;
- 10 Fig. 3b illustrates a further illustration of an enhanced sound field comprising audio data and meta data relating to spatial information such as geometrical information for each sound field description;
- 15 Fig. 4a illustrates an implementation of an apparatus for generating a modified sound field description;
- Fig. 4b illustrates a further implementation of an apparatus for generating a modified sound field description;
- 20 Fig. 4c illustrates a scenario with a reference position/location A, a further reference position/location B, and a different reference location due to translation;
- 25 Fig. 5 illustrates the 6DoF reproduction of spatial audio in a general sense;
- Fig. 6a illustrates a preferred embodiment for the implementation of a sound field calculator;
- 30 Fig. 6b illustrates a preferred implementation for calculating a new DoA and a new distance of a sound source with respect to a new/different reference location;
- 35 Fig. 6c illustrates a preferred embodiment of a 6DoF reproduction comprising an apparatus for generating an enhanced sound field description, for example, for each individual sound field description and an apparatus for generating a modified sound field description for the matched sources;

- Fig. 7 illustrates a preferred embodiment for selecting the one of the first and the second sound field descriptions for the calculation of a modified sound field for a broadband or narrow band object;
- 5 Fig. 8 illustrates an exemplary device for generating a sound field description from an audio signal such a mono-signal and direction of arrival data;
- Fig. 9 illustrates a further preferred embodiment for the sound field calculator;
- 10 Fig. 10 illustrates a preferred implementation of the apparatus for generating a modified sound field description;
- Fig. 11 illustrates a further preferred implementation of an apparatus for generating a modified sound field description;
- 15 Fig. 12a illustrates a prior art DirAC analysis implementation; and
- Fig. 12b illustrates a prior art DirAC synthesis implementation.
- 20 To enable 6DoF applications for the mentioned Ambisonics / DirAC representations, it is necessary to extend these representations in a way that provides the missing information for translational processing. It is noted that this extension could, e.g., 1) add the distance or positions of the objects to the existing scene representation, and/or 2) add information that would facilitate the process of separating the individual objects.
- 25 It is furthermore an objective of embodiments to preserve / re-use the structure of the existing (non-parametric or parametric) Ambisonics systems to provide backward compatibility with these representations/systems in the sense that
- 30 • the extended representations can be converted into the existing non-extended ones (e.g. for rendering) , and
- allow re-use of existing software and hardware implementations when working with the extended representation.
- 35 In the following, several approaches are described, namely one limited (but very simple) approach and three different extended Ambisonics formats to enable 6DoF.

The sound scene is described using two or more Ambisonics signals each describing the sound scene at a different position, or in other words from a different perspective. It is assumed that the relative positions are known. A modified Ambisonics signal at a desired position in the sound scene is generate from the input Ambisonics signals. A signal-based
5 or parametric-based approach can be used to generate a virtual Ambisonics signal at the desired position.

The concept of multi-point Ambisonics representation is applicable for both traditional and
10 parametric (DirAC-style) Ambisonics.

A virtual Ambisonics signal at a desired position (i.e., after translation) is computed using the following steps in a signal-based translation embodiment:

- 15 1. Objects are generated by applying source separation to each traditional Ambisonics signal.
2. The DOA of all objects are computed for each traditional Ambisonics signal.
- 20 3. The objects extracted from one traditional Ambisonics signal are matched to the objects extracted from the other traditional Ambisonics signals. The matching is performed based on the corresponding DOAs and/or the signals (e.g., by means of correlation / coherence).
- 25 4. The positions of the matched objects are estimated based on triangulation.
5. Each matched object (single-channel input) is modified based on the estimated position and the desired position (i.e., after translation) using a distance compensation filter.
- 30 6. The DOA at the desired position (i.e., after translation) is computed for each matched object. This DOA is represented by DOA'.
7. An Ambisonics object signal is computed for each matched object. The
35 Ambisonics object signal is generated such that the matched object has a direction-of-arrival DOA'.

8. An Ambisonics object signal is computed for each non-matched object. The Ambisonics object signal is generated such that the non-matched object has a direction-of-arrival DOA.

5 9. The virtual Ambisonics signal is obtained by adding all Ambisonics object signals together.

A virtual Ambisonics signal at a desired position (i.e., after translation) is computed using the following steps in a parametric-based translation embodiment in accordance with a
10 further embodiment:

1. A sound field model is assumed. The sound field can be decomposed into one or more direct sound components and diffuse sound components. The direct sound components consist of a signal and position information (e.g., in polar or Cartesian
15 coordinates). Alternatively, the sound field can be decomposed into one or more direct / principle sound components and a residual sound component (single-or multi-channel).

2. The signal components and parameters of the assumed sound field model are estimated using the input Ambisonics signals.
20

3. The signal components and/or parameters are modified depending on the desired translation, or desired position, in the sound scene.

4. The virtual Ambisonics signal is generated using the modified signal components
25 and modified parameters.

Generating multi-point Ambisonics signals is simple for computer-generated and produced content as well as in the context of natural recording via microphone arrays or spatial micro-phones (e.g., B-format microphone). In the embodiment, it is preferred to perform a
30 source matching subsequent to step 2 or a triangulation calculation before step 3. Furthermore, one or more steps of both embodiments can also be used in the corresponding other embodiments.

A change in orientation can be realized by applying a single rotation to the virtual
35 Ambisonics signal.

Fig. 1a illustrates an apparatus for generating an enhanced sound field description comprising a sound field (description) generator 100 for generating at least one sound

field description indicating a sound field with respect to at least one reference location. Furthermore, the apparatus comprises a meta data generator 110 for generating meta data relating to spatial information of the sound field. The meta data receives, as an input, the sound field or alternatively or additionally, separate information on sound sources.

5

Both, the output of the sound field description generator 100 and the meta data generator 110 constitute the enhanced sound field description. In an embodiment, both, the output of the sound field description generator 100 and the meta data generator 110 can be combined within a combiner 120 or output interface 120 to obtain the enhanced sound field description that includes the spatial meta data or spatial information of the sound field as generated by the meta data generator 110.

10

Fig. 1b illustrates the situation that is addressed by the present invention. The position A, for example, is the at least one reference location and a sound field is generated by source A and source B and a certain actual or, for example, virtual microphone being located at the position A detects the sound from source A and source B. The sound is a superposition of the sound coming from the emitting sound sources. This represents the sound field description as generated by the sound field description generator.

15

Additionally, the meta data generator would, by certain implementations derive a spatial information with respect to source A and another spatial information with respect to source B such as the distances of these sources to the reference position such as position A.

20

Naturally, the reference position could, alternatively, be position B. Then, the actual or virtual microphone would be placed at position B and the sound field description would be a sound field, for example, represented by the first-order Ambisonics components or higher-order Ambisonics components or any other sound components having the potential to describe a sound field with respect to at least one reference location, i.e., position B.

25

The meta data generator might, then, generate, as the information on the sound sources, the distance of sound source A to position B or the distance of source B to position B. Alternative information on sound sources could, of course, be the absolute or relative position with respect to a reference position. The reference position could be the origin of a general coordinate system or could be located in a defined relation to the origin of a general coordinate system.

30

35

Other meta data could be the absolute position of one sound source and the relative position of another sound source with respect to the first sound source and so on.

Fig. 2 illustrates an apparatus for generating an enhanced sound field description, where
5 the sound field generator comprises a sound field generator 250 for the first sound field, a sound field generator 260 for the second sound field and, an arbitrary number of sound field generators for one or more sound fields such as a third, fourth and so on sound field. Additionally, the metadata is configured to calculate and forward to the combiner 120 an
10 information on the first sound field and the second sound field. All this information is used by the combiner 120 in order to generate the enhanced sound field description. Thus, the combiner 120 is also configured as an output interface to generate the enhanced sound field description.

Fig. 3a illustrates an enhanced sound field description as a datastream comprising a first
15 sound field description 330, a second sound field description 340 and, associated thereto, the metadata 350 comprising information on the first sound field description and the second sound field description. The first sound field description can, for example, be a B-format description or a higher-order description or any other description that allows to determine a directional distribution of sound sources either in a full-band representation or
20 in a frequency-selected representation. Thus, the first sound field description 330 and the second sound field description 340 can, for example, also be parametric sound field descriptions for the different reference locations having a, for example, a downmix signal and directional of arrival data for different time/frequency bins.

25 Nevertheless, the geometrical information 350 for the first and the second sound field descriptions is the same for all sources included in the first sound field description 330 or, for the sources in the second sound field description 340, respectively. Thus, when, exemplarily there does exist three sources in the first sound field description 330 and a
30 geometrical information on the first sound field description then this geometrical information is the same for the three sources in the first sound field description. Analogously, when there, for example, exists five sources in the second sound field description, then the geometrical information for the second sound field included in the metadata 350 is the same for all the sources in the second sound field description.

Fig. 3b illustrates an exemplary construction of the metadata 350 of Fig. 3a. In an embodiment, the reference location 351 can be included in the metadata. However, this is not necessarily the case in the reference location information 351 can also be omitted.

5 For the first sound field, a first geometrical information is given which can, for example, be an information on vector A illustrated in Fig. 4c pointing from an origin to the reference position/location A, to which the first sound field is related.

10 The second geometrical information can, for example, be an information on the vector B pointing from the origin to the second reference position/location B, to which the second sound field description is related.

A and B are the reference locations or recording positions for both sound field descriptions.

15

Alternative geometrical information can, for example, be an information on the vector D extending between reference location A and the further reference location B and/or an origin and a vector pointing from the origin to one of both points. Thus, the geometrical information included in the metadata may comprise vector A and vector D or may
20 comprise vector B and vector D or may comprise vector A and vector B without vector D or may comprise other information, from which the reference location A and the reference location B can be identified in a certain three-dimensional coordinate system. However, the same consideration is additionally apply for a two-dimensional sound description as well as particularly illustrated in Fig. 4c that only shows the two-dimensional case.

25

Fig. 4a illustrates a preferred implementation of an apparatus for generating a modified sound field description from a sound field description and meta data relating to spatial information of the sound field description. Particularly, the apparatus comprises a sound field calculator 420 that generates the modified sound field using meta data, the sound field description and translation information indicating a translation from a reference location to a different reference location.
30

In an embodiment, the sound field calculator 420 is connected to an input interface 400 for receiving the enhanced sound field description as, for example, discussed with respect to Fig. 1a or 2 and the input interface 400 then separates the sound field description on the
35 one hand, i.e., what has been generated by block 100 of Fig. 1a or block 210 of Fig. 2.

Furthermore, the input interface 400 separates the meta data from the enhanced sound field description, i.e., item 350 of Fig. 3a or optional 351 and 352 to 354 of Fig. 3b.

5 Furthermore, a translation interface 410 obtains the translation information and/or additional or separate rotation information from a listener. An implementation of the translation interface 410 can be a head-tracking unit that not only tracks the rotation of a head in a virtual reality environment, but also a translation of the head from one position, i.e., position A in Fig. 1b to another position, i.e., position B in Fig. 1b.

10 Fig. 4b illustrates another implementation similar to Fig. 1a, but not related to an encoder/decoder scenario, but related to a general scenario where the meta data supply indicated by a meta data supplier 402, the sound field supply indicated by a sound field supplier 404 are done without a certain input interface separating an encoded or enhanced sound field description, but are all done, for example, in an actual scenario
15 existing, for example, in a virtual reality application. However, the present invention is not limited to virtual reality applications, but can also be implemented in any other applications, where the spatial audio processing of sound fields that are related to a reference location is useful in order to transform a sound field related to a first reference location to another sound field related to a different second reference location.

20

The sound field calculator 420 then generates the modified sound field description or, alternatively, generates a (virtual) loudspeaker representation or generates a binaural representation such as a two-channel representation for a headphone reproduction. Thus, the sound field calculator 420 can generate, as the modified sound field, a modified sound
25 field description, being basically the same as the original sound field description, but now with respect to a new reference position. In an alternative embodiment, a virtual or actual loudspeaker representation can be generated for a predetermined loudspeaker setup such as 5.1 scheme or a loudspeaker setup having more loudspeakers and, particularly, having a three-dimensional arrangement of loudspeakers rather than only a two-
30 dimensional arrangement, i.e., a loudspeaker arrangement having loudspeakers being elevated with respect to the user position. Other applications that are specifically useful for virtual reality applications are applications for binaural reproduction, i.e., for a headphone that can be applied to the virtual reality user's head.

35 Exemplarily, the subsequently described Fig. 6 illustrates a situation, where a DirAC synthesizer only operates on a downmix component such as the omnidirectional or pressure component, while, in a further alternative embodiment illustrated with respect to Fig. 12b, the DirAC synthesizer operates on the whole sound field data, i.e., the full

component representation having, in this embodiment in Fig. 12b, a field description with an omnidirectional component w and three directional components x , y , z .

Fig. 4c illustrates the scenario underlying preferred embodiments of the present invention.

5 The Figure illustrates a first reference position/location A, a second reference position/location B and two different sound sources A and B, and a translation vector l .

Both sound sources A and B are included in the sound field description related to reference location A and the second sound field description related to reference position
10 B.

In order to calculate the distance of source A, for example, to the first reference position or to the second reference position, both the different sound field descriptions related to A and B are subjected to a source separation procedure and, then, a matching of the
15 sources obtained by these different sound separation procedures is obtained. This will result in source A, for example. Source A is found in the source separation algorithm for the first sound field description and also for the second sound field description. The direction of arrival information for source A will be, when obtained from the first sound field description related to reference position A the angle α . Additionally, the direction of arrival
20 information for the same source A but now obtained from the second sound field description related to the further reference position B will be angle β .

Now, based on the known or calculable distance D that is, for example, obtainable or calculable from the metadata for the sound field descriptions, and based on the two
25 angles α and β , the triangle defined by source A, the reference position A and the reference position B is fully defined. Thus, the distance from source A to reference position A or the distance from source A to reference position B or the general position of source A, i.e., the vector pointing from the origin to the actual position of source A can be calculated, for example by triangulation processing operations. The position or distance
30 both represent information on a distance or on a position.

The same procedure can then be performed for each matched source, i.e., also for source B.

35 Thus, a distance/position information for each matched source is calculated and, then, each matched source can be processed as if the distance/position is fully known or is, for example, given by additional metadata. However, only the geometrical information for the

first sound field description and the second sound field description is necessary instead of any distance/depth information for each individual source.

Fig. 8 illustrates another implementation for performing a synthesis different from the DirAC synthesizer. When, for example, a sound field analyzer generates, for each source signal, a separate mono signal S and an original direction of arrival and when, depending on the translation information, a new direction of arrival is calculated, then the Ambisonics signal generator 430 of Fig. 8, for example, would be used to generate a sound field description for the sound source signal, i.e., the mono signal S but for the new direction of arrival (DoA) data consisting of a horizontal angle θ or an elevation angle θ and an azimuth angle φ . Then, a procedure performed by the sound field calculator 420 of Fig. 4b would be to generate, for example, a first-order Ambisonics sound field representation for each sound source with the new direction of arrival and, then, a further modification per sound source could be performed using a scaling factor depending on the distance of the sound field to the new reference location and, then, all the sound fields from the individual sources could superposed to each other to finally obtain the modified sound field, once again, in, for example, an Ambisonics representation related to a certain new reference location.

When one interprets that each time/frequency bin processed by a DirAC analyzer 422, 422a, 422b of Fig. 6 represents a certain (bandwidth limited) sound source, then the Ambisonics signal generator 430 could be used, instead of the DirAC synthesizer 425, 425a, 425b to generate, for each time/frequency bin, a full Ambisonics representation using the downmix signal or pressure signal or omnidirectional component for this time/frequency bin as the "mono signal S " of Fig. 8. Then, an individual frequency-time conversion in frequency-time converter for each of the W, X, Y, Z component would then result in a sound field description different from what is illustrated in Fig. 4c.

The scene is recorded from the point of view (PoV) of the microphone, which position is used as the origin of the reference coordinate system. The scene has to be reproduced from the PoV of the listener, who is tracked in 6DoF, cf. Fig. 5. A single sound source is shown here for illustration, the relation holds for each time-frequency bin.

Fig. 5 illustrates the 6DoF reproduction of spatial audio. A sound source is recorded by a microphone with the DoA r_r in the distance d_r relative to the microphones position and orientation (black line and arc). It has to be reproduced relative to the moving listener with the DoA r_l and distance d_l (dashed). This has to consider the listeners translation l and

rotation \mathbf{o} (dotted). The DOA is represented as a vector with unit length pointing towards the source.

The sound source at the coordinates $\mathbf{d}_r \in \mathbb{R}^3$ is recorded from the direction of arrival (DoA) expressed by the unit vector $\mathbf{r}_r = \mathbf{d}_r / \|\mathbf{d}_r\|$. This DoA can be estimated from analysis of the recording. It is coming from the distance $d_r = \|\mathbf{d}_r\|$. It is assumed that this information can be derived from the meta data for each source or, generally, from the item 352, 353, 354 of Fig. 3b, and can be represented as distance description having any direction r from the recording position to the distance (e.g. given in meters or so) as obtained by for example triangulation processing using two angles with respect to two different reference locations and the distance/positions or the reference locations.

The listener is tracked in 6DoF. At a given time, he is at a position $\mathbf{l} \in \mathbb{R}^3$ relative to the microphone and has a rotation $\mathbf{o} \in \mathbb{R}^3$ relative to the microphones' coordinates system. The recording position is chosen as the origin of the coordinate system to simplify the notation.

Thus the sound has to be reproduced with a different distance d_1 , leading to a changed volume, and a different DoA \mathbf{r}_1 that is the result of both translation and subsequent rotation.

A method for obtaining a virtual signal from the listeners perspective by dedicated transformations based on a parametric representation, as explained in the following section, is outlined.

The proposed method is based on the basic DirAC approach for parametric spatial sound encoding cf. [16]. It is assumed that there is one dominant direct source per time-frequency instance of the analyzed spectrum and these can be treated independently. The recording is transformed into a time-frequency representation using short time Fourier transform (STFT). The time frame index is denoted with n and the frequency index with k . The transformed recording is then analyzed, estimating directions $\mathbf{r}_r(k, n)$ and diffuseness $\psi(k, n)$ for each time-frequency bin of the complex spectrum $P(k, n)$. In the synthesis, the signal is divided into a direct and diffuse part. Here, loudspeaker signals are computed by panning the direct part depending on the speaker positions and adding the diffuse part.

The method for transforming an FOA signal according to the listeners perspective in 6DoF can be divided into five steps, cf. Fig. 6c.

Fig. 6c illustrates a method of 6DoF reproduction. The recorded FOA signal in B-Format
 5 is processed by a DirAC encoder that computes direction and diffuseness values for each time-frequency bin of the complex spectrum. The direction vector is then transformed by the listener's tracked position and according to the distance information given in a distance map for each source derived by e.g. triangulation calculations. The resulting direction vector is then rotated according to the head rotation. Finally, signals for 8+4
 10 virtual loudspeaker channels are synthesized in the DirAC decoder. These are then binauralized.

In the embodiment, the input signal is analyzed in the DirAC encoder 422, the distance information is added from the distance map $m(r)$ giving a distance for each (matched)
 15 source, then the listener's tracked translation and rotation are applied in the novel transforms 423 and 424. The DirAC decoder 425 synthesizes signals for 8+4 virtual loudspeakers, which are in turn binauralized 427 for headphone playback. Note that as the rotation of the sound scene after the translation is an independent operation, it could be alternatively applied in the binaural renderer. The only parameter transformed for
 20 6DoF is the direction vector. By the model definition, the diffuse part is assumed to be isotropic and homogeneous and thus is kept unchanged.

The input to the DirAC encoder is an FOA sound signal in B-format representation. It consists of four channels, i.e., the omnidirectional sound pressure and the three first-
 25 order spatial gradients, which under certain assumptions are proportional to the particle velocity. This signal is encoded in a parametric way, cf. [18]. The parameters are derived from the complex sound pressure $P(k, n)$, which is the transformed omnidirectional signal and the complex particle velocity vector $\mathbf{U}(k, n) = [U_x(k, n), U_y(k, n), U_z(k, n)]^T$ corresponding to the transformed gradient signals.

30 The DirAC representation consists of the signal $P(k, n)$, the diffuseness $\psi(k, n)$ and direction $\mathbf{r}(k, n)$ of the sound wave at each time-frequency bin. To derive the latter, first, the active sound intensity vector $\mathbf{I}_a(k, n)$ is computed as the real part (denoted by $\text{Re}(\cdot)$) of the product of pressure vector with the complex conjugate (denoted by $(\cdot)^*$) of the
 35 velocity vector [18]:

$$\mathbf{I}_a(k, n) = \frac{1}{2} \text{Re}(P(k, n) \mathbf{U}^*(k, n)). \quad (1)$$

5

The diffuseness is estimated from the coefficient of Variation of this vector [18].

$$\psi(k, n) = \sqrt{1 - \frac{\|E\{\mathbf{I}_a(k, n)\}\|}{E\{\|\mathbf{I}_a(k, n)\|\}}}. \quad (2)$$

10

where E denotes the expectation operator along time frames, implemented as moving average.

15 Since it is intended to manipulate the sound using a direction-based distance map having a distance for each (matched) source to the reference location, the variance of the direction estimates should be low in an optional embodiment. As the frames are typically short, this is not always the case. Therefore, a moving average is applied to obtain a smoothed direction estimate $\bar{\mathbf{I}}_a(k, n)$. The DoA of the direct part of the signal is then, in an
20 embodiment computed as unit length vector in the opposite direction:

$$\mathbf{r}_r(k, n) = - \frac{\bar{\mathbf{I}}_a(k, n)}{\|\bar{\mathbf{I}}_a(k, n)\|} \quad (3)$$

25 As the direction is encoded as a three-dimensional vector of unit length for each time-frequency bin, it is straightforward to integrate the distance information. The direction vectors are multiplied with their corresponding map entry such that the vector length represents the distance of the corresponding sound source $d_r(k, n)$:

30

$$\begin{aligned} \mathbf{d}_r(k, n) &= \mathbf{r}_r(k, n) d_r(k, n) \\ &= \mathbf{r}_r(k, n) m(\mathbf{r}_r(k, n)) \end{aligned} \quad (4)$$

35

where $\mathbf{d}_r(k, n)$ is a vector pointing from the recording position of the microphone to the sound source active at time n and frequency bin k .

The listener position is given by the tracking system for the current processing frame as $l(n)$. With the vector representation of source positions, one can subtract the tracking position vector $l(n)$ to yield the new, translated direction vector $\mathbf{d}_1(k, n)$ with the length $d_1(k, n) = \|\mathbf{d}_1(k, n)\|$, cf. Fig. 6b. The distances from the listener's PoV to the sound sources are derived, and the DoAs are adapted in a single step:

$$\mathbf{d}_1(k, n) = \mathbf{d}_r(k, n) - l(n) \quad (5)$$

An important aspect of realistic reproduction is the distance attenuation. The attenuation is assumed to be a function of the distance between sound source and listener [19]. The length of the direction vectors is to encode the attenuation or amplification for reproduction. The distance to the recording position is encoded in $\mathbf{d}_r(k, n)$ according to the distance map, and the distance to be reproduced encoded in $d_1(k, n)$. If one normalizes the vectors to unit length and then multiply by the ratio of old and new distance, one sees that the required length is given by dividing $d_1(k, n)$ by the length of the original vector:

$$\mathbf{d}_v(k, n) = \frac{\mathbf{d}_1(k, n)}{\|\mathbf{d}_1(k, n)\|} \frac{\|\mathbf{d}_1(k, n)\|}{\|\mathbf{d}_r(k, n)\|} = \frac{\mathbf{d}_1(k, n)}{\|\mathbf{d}_r(k, n)\|} \quad (6)$$

The changes for the listener's orientation are applied in the following step. The orientation given by the tracking can be written as vector composed of the pitch, yaw, and roll $\mathbf{o}(n) = [o_x(n), o_z(n), o_y(n)]^T$ relative to the recording position as the origin. The source direction is rotated according to the listener orientation, which is implemented using 2D rotation matrices:

$$\mathbf{d}_p(k, n) = R_Y(o_y(n))R_Z(o_z(n))R_X(o_x(n))\mathbf{d}_v(k, n) \quad (7)$$

30

The resulting DoA for the listener is then given by the vector normalized to unit length:

$$\mathbf{r}_p(k, n) = \frac{\mathbf{d}_p(k, n)}{\|\mathbf{d}_p(k, n)\|} \quad (8)$$

The transformed direction vector, the diffuseness, and the complex spectrum are used to synthesize signals for a uniformly distributed 8+4 virtual loudspeaker setup. Eight virtual speakers are located in 45° azimuth steps on the listener plane (elevation 0°), and four in a 90° cross formation above at 45° elevation. The synthesis is split into a direct and diffuse part for each loudspeaker channel $1 \leq i \leq I$, where $I = 12$ is the number of loudspeakers [16]:

$$Y_i(k, n) = Y_{i,S}(k, n) + Y_{i,D}(k, n) \quad (9)$$

10

For the direct part, edge fading amplitude panning (EFAP) panning is applied to reproduce the sound from the right direction given the virtual loudspeaker geometry [20]. Given the DoA vector $\mathbf{r}_p(k, n)$, this provides a panning gain $G_i(\mathbf{r})$ for each virtual loudspeaker channel i . The distance-dependent gain for each DoA is derived from the resulting length of the direction vector, $\mathbf{d}_p(k, n)$. The direct synthesis for channel i becomes:

15

$$Y_{i,S}(k, n) = \sqrt{1 - \psi(k, n)} P(k, n) G_i(\mathbf{r}_p(k, n)) (\|\mathbf{d}_p(k, n)\|)^{-\gamma} \quad (10)$$

20

where the exponent γ is a tuning factor that is typically set to about 1 [19]. Note that with $\gamma = 0$ the distance-dependent gain is turned off.

25

The pressure $P(k, n)$ is used to generate I decorrelated signals $\tilde{P}_i(k, n)$. These decorrelated signals are added to the individual loudspeaker channels as the diffuse component. This follows the standard method [16]:

30

$$Y_{i,D}(k, n) = \sqrt{\psi(k, n)} \frac{1}{\sqrt{I}} \tilde{P}_i(k, n) \quad (11)$$

35

The diffuse and direct part of each channel are added together, and the signals are transformed back into the time domain by an inverse STFT. These channel time domain signals are convolved with HRTFs for the left and right ear depending on the loudspeaker position to create binauralized signals.

Fig. 6a illustrates a further preferred embodiment for calculating the modified sound field using the spatial information, and the first and the second sound field descriptions and the translation information indicating a translation of a reference location to a different
5 reference location as, for example, discussed with respect to vector l in Fig. 4c or Fig. 5.

Fig. 6a illustrates block 700 indicating an application of a sound separation or, generally, sound analysis procedure to the first sound field description related to reference position A of Fig. 4c and the second sound field description related to reference position B of Fig.
10 4c.

This procedure will result in a first group of one or more extracted objects and, additionally, in a second group of one or more extracted objects.

15 These groups are used within block 702 for calculating the direction of arrival information for all separated sources, i.e., for the first group of extracted sources and the second group of one or more extracted sources.

In other embodiments, steps 700 and 702 are implemented within a single procedure providing, on the one hand, the signal for the source and on the other hand the DoA
20 information for the source. This is also true for parametric procedures such as time/frequency-selective procedures as DirAC, where the source signal is the signal of the B-format representation in a time/frequency bin or the pressure signal or omnidirectional signal of the time/frequency bin and the DoA information as the DoA parameter for this
25 specific bin.

Then, in step 704, a source matching is performed between the sources of the first group and the sources of the second group and the result of the source matching are matched
30 sources.

These matched sources are used for computing a sound field for each matched object using the new DoA and the new distance as illustrated in block 710. Furthermore, the directional of arrival information of the matched objects, i.e., two per each object such as α and β of Fig. 4c for source A are used in block 706 in order to calculate the positions of
35 the matched objects or alternatively or additionally, the distances of the matched objects using, for example, triangulation operations.

The result of block 706 is the position of each matched object or alternatively or additionally, the distance of a matched object to one of the first or the second reference location A, B, illustrated, for example in Fig. 4c.

5

Additionally, it is preferred to not only use translation information in block 708 but also rotation information for calculating the new direction of arrival information and the new distances for the matched objects.

10 Although it has been outlined that the positions of the matched objects are input into step 708, it is to be emphasized, that for only calculating the new direction of arrival information for a matched object, the actual position of the matched object or, in other words, the distance of the matched object is not necessary for calculating the new direction of arrival with respect to a new (different) reference location, to which a listener
15 has moved to, for example, the distance is not necessary.

However, the distance is then necessary in order to adapt the source signal to the new situation. Thus, when the distance of the source or sound object to the new reference position has become shorter, then a scaling factor will be calculated that is lower than
20 one. When, however, the distance becomes higher, then a scaling factor is calculated to be higher than one as, for example, discussed with respect to Fig. 6b. Hence, although illustrated in Fig. 6a for an embodiment, it is not necessarily the case that explicit positions of the matched objects and, then, the distances of the matched objects are calculated and, then, the sound field is calculated for each matched object using the new
25 direction of arrival and the new distance. Instead, only the distance of a matched object to one reference location of the two reference locations is generally sufficient and, then, a sound field for each matched object is calculated using the new DoA and the new distance.

30 Additionally, block 714 illustrates the calculation of sound fields for the non-matched objects using the old DoA information obtained by block 702. Furthermore, the sound fields for the matched objects obtained in blocks 710 and the non-matched objects obtained by block 714 are combined in block 712 in order to obtain the modified sound field description that can, for example, be an Ambisonics description such as a first-order
35 Ambisonics description, a higher-order Ambisonics description or, alternatively, a loudspeaker channel description related to certain loudspeaker setup that, of course, is

the same for block 710 and block 714 so that a simple channel-by-channel addition can be performed in block 712.

Fig. 6b illustrates a preferred implementation of the sound field calculator 420. In block 5 1102, a source separation and a direction of arrival or generally direction information calculation for each source is performed. Then, in block 1104, the direction of arrival vector is multiplied by the distance information vector, i.e., the vector from the original reference location to the sound source, i.e., the vector from item 520 to item 510 of Fig. 5, for example. Then, in block 1106, the translation information, i.e., the vector from item 520 10 to item 500 of Fig. 5 is taken into account in order to calculate the new translated direction vector that is the vector from the listener position 500 to the sound source position 510. Then, the new direction of arrival vector with the correct length indicated by d_v is calculated in block 1108. This vector is directed in the same direction as d_r , but has a different length, since the length of this vector reflects the fact that the sound source 510 15 is recorded in the original sound field with a certain volume and, therefore, the length of d_v more or less indicates the loudness change. This is obtained by dividing vector d_l by the recording distance d_r , i.e., the length of vector d_r from the microphone 520 to the sound source 510. As stated, the length of the vector d_r from the microphone 520 to the sound source 510 can be derived by triangulation calculation. When the microphone is in the 20 reference location of the first sound field description, then the distance from the reference location of the first sound field description to the sound source is used. When, however, the microphone is in the further reference location of the second sound field description, then the distance from the further reference location of the second sound field description to the sound source is used.

25

When, as in Fig. 5, the reproduced distance is greater than the recorded distance, then the length of d_v will be lower than unity. This will result an attenuation of the sound source 510 for the reproduction at the new listener position. When, however, the reproduced distance d_l is smaller than the recorded distance, then the length of d_v as calculated by 30 block 1108 will be greater than 1 and a corresponding scaling factor will result in an amplification of the sound source.

In Fig. 6a, item 710 indicates that the sound field for each matched object is calculated using the new direction of arrival information and the new distance. However, basically, 35 for computing the sound field for each matched object, the object signals obtained from either the first group of one or more extracted sources or the second group of one or more extracted sources can be used in general. In an embodiment, however, a specific

selection illustrated in Fig. 7 is performed in order to determine which sound field description is used for performing the sound field computation in block 710. In block 720, the first distance of the new listener position to the first reference location of the first sound field description is determined. With respect to Fig. 4c, this is the distance
5 between the different reference location and reference position A.

Furthermore, in step 722, the second distance of the new listener position to the second reference location of the second sound field description is determined. In this embodiment of Fig. 4c, this would be the distance between the different reference
10 location (due to translation) and reference position B.

It appears that the distance from the different reference location to reference position B is lower than the difference from the different reference location to the reference position A. Thus, this would be determined in step 724. And, in step 726, the object signal is
15 selected from the group derived from the sound field description with the smaller distance. Thus, in order to render sources A and B which correspond to matched sources in Fig. 4c illustration, the sound source signals derived from the second sound field description related to the further reference position B would be used.

20 In other embodiments, however, where the translation points from the origin to a different reference location, for example, to the left in the Fig. 4c illustration, the smaller distance would be from this other reference location to the reference position A and, then, the first sound field description would be used for finally computing the sound field for each matched object in block 710 of Fig. 6b. Again, the selection would be performed by the
25 procedure illustrated in Fig. 7.

Fig. 9 illustrates a further preferred embodiment. In step 740, a sound field analysis on the first sound field description is performed, for example, a parametric sound field analysis in the form of a DirAC analysis illustrated in block 422 of Fig. 6c.

30

This results in a first set of parameters, for example, for each time/frequency bin, where each set of parameters comprises a DoA parameter and, optionally, a diffuseness parameter.

35 In step 741, a sound field analysis is performed on the second sound field description and, again, a DirAC analysis is performed as in block 740 and as, for example,

discussed with respect to block 422 of Fig. 6c.

This results in a second set of parameters, for example, for time/frequency bins.

5 Then, in block 746, a position for each parameter pair can be determined using the corresponding DoA parameter from the first time/frequency bin and the DoA parameter from the same time/frequency bin from the second set of parameters. This will result in a position for each parameter pair. However, the position will be more useful the lower the diffuseness for the corresponding time/frequency bin is in the first set of parameters
10 and/or the second set of parameters.

Thus, it is preferred to only further use the positions from the time/frequency bins that have resulted in a quite low diffuseness in both the first and the second set of parameters.

15

Additionally, it is preferred to also perform a correlation for the corresponding signals in the time/frequency bin as also output by block 740 and block 741.

Thus, the "source matching" of step 704 in Fig. 6a can, for example, be fully avoided and
20 be replaced by a determination of matched sources/matched time/frequency bins based on the diffuseness parameters or the matching can be performed additionally using the corresponding signal in the time/frequency bin from the B-format components for example, or from the pressure signal or object signal output by block 422 of Fig. 6c.

25 In any case, block 46 will result in certain positions for certain (selected) time/frequency bins that correspond to the "matched objects" found in block 704 of Fig. 6a.

Then, in block 748, modified parameters and/or signals for the positions obtained by block 746 and/or the corresponding translation/rotation as obtained, for example, by a
30 hat tracker are calculated and the output of block 748 represents modified parameters and/or modified signals for different time/frequency bins.

Thus, block 748 may correspond to the translation transform 423 and rotation transform of block 424 for the purpose of calculating modified parameters and the calculation of
35 modified signals would, for example, be performed by block 425 of Fig. 6c preferably also under the consideration of a certain scaling factor derived from the positions for the

corresponding time/frequency bins.

Finally, a synthesis of the sound field description is performed in block 750 using the modified data. This can, for example, be done by a DirAC synthesis using either the first
5 or the second sound field description or can be performed by Ambisonics signal generator as illustrated in block 425 and the result will be the new sound field description for transmission/storage/rendering.

Fig. 10 illustrates a further preferred implementation of the sound field calculator 420. At
10 least parts of the procedure illustrated in Fig. 10 are performed for each matched source separately. The block 1120 determines the distance for a matched source e.g. by triangulation calculation.

Based on the sound field description, a full band direction of arrival or a per band direction
15 of arrival is determined in 1100. These direction of arrival information represent the direction of arrival data of the sound field. Based on this direction of arrival data, a translation transformation is performed in block 1110. To this end, block 1120 calculates the distance for each matched source. Based on the data, block 1110 generates the new direction of arrival data for the sound field that, in this implementation, only depends on
20 the translation from the reference location to the different reference location. To this end, block 1110 receives the translation information generated, for example, by a tracking in the context of a virtual reality implementation.

Preferably or alternatively, a rotation data is used as well. To this end, block 1130
25 performs a rotation transformation using the rotation information. When both the translation and the rotation is performed, then it is preferred to perform the rotation transformation subsequent to the calculation of the new DoAs of the sound field that already include the information from the translation and the source distance from block 1120.

30

Then, in block 1140, the new sound field description is generated. To this end, the original sound field description can be used or, alternatively, source signals that have been separated from the sound field description by a source separation algorithm can be used or any other applications can be used. Basically, the new sound field description can be,
35 for example, a directional sound field description as obtained by the Ambisonics generator 430 or as generated by a DirAC synthesizer 425 or can be a binaural representation generated from a virtual speaker representation in the subsequent binaural rendering.

Preferably, as illustrated in Fig. 10, the distance per direction of arrival is also used in generating the new sound field description in order to adapt the volume or loudness of a certain sound source to the new location, i.e., the new or different reference location.

5

Although Fig. 10 illustrates a situation, where the rotation transformation is performed subsequent to the translation transformation, it is to be noted that the order can be different. Particularly, the rotation transformation can be applied to the DoAs of the sound field as generated by block 1100 and, then, the additional translation transformation is applied that is due to the translation of a subject from the reference location to the different reference location.

As soon as the DoAs of the sound field have been determined by block 1100, the distance information is acquired from the meta data using block 1120 and this distance information is then used by generating the new sound field description in block 1140 for accounting for a changed distance and, therefore, a changed loudness of the certain source with respect to a certain reference location. Basically, it can be said that in case the distance becomes larger, then the specific sound source signal is attenuated while, when the distance becomes shorter, then the sound source signal is amplified. Naturally, the attenuation or amplification of the certain sound source depending on the distance is made in proportion to the distance change, but, in other embodiments, less complex operations can be applied to this amplification or attenuation of sound source signals in quite coarse increments. Even such a less complex implementation provides superior results compared to a situation where any distance change is fully neglected.

20
25

Fig.11 illustrates a further preferred implementation of the sound field calculator. In block 1200, the individual sources from the sound field are determined, for example, per band or full band like. When a determination per frame and band is performed, then this can be done by a DirAC analysis. If a full band or subband determination is performed, then this can be done by any kind of a full band or subband source separation algorithm.

30

In block 1210, a translation and/or a rotation of a listener is determined, for example, by head tracking.

In block 1220, an old distance for each source is determined by using the meta data and, for example, by using the meta data for the triangulation calculation. Thus, each band is considered to be a certain source (provided that the diffuseness is lower than a certain

35

threshold), and then, a certain distance for each time/frequency bin having a low diffuseness value is determined.

5 Then, in block 1230, a new distance per source is obtained, for example, by a vector calculation per band that is, for example, discussed in the context of Fig. 6b.

Furthermore, as illustrated in block 1240, an old direction per source is determined, for example, by a DoA calculation obtained in a DirAC analysis or by a direction of arrival or direction information analysis in a source separation algorithm, for example.

10

Then, in block 1250, a new direction per source is determined, for example by performing a vector calculation per band or full band.

Then, in block 1260, a new sound field is generated for the translated and rotated listener.

15

This can be done, for example, by scaling the direct portion per channel in the DirAC synthesis. Depending on the specific implementation, the distance modification can be done in blocks 1270a, 1270b or 1270c in addition or alternatively to performing the distance modification in block 1260.

20

When, for example, it is determined that the sound field only has a single source, then the distance modification can already be performed in block 1270a.

Alternatively, when individual source signals are calculated by block 1200, then the distance modification can be performed for the individual sources in block 1270b, before
25 the actual new sound field is generated in block 1260.

30

Additionally, when the sound field generation in block 1260, for example, does not render a loudspeaker setup signal or a binaural signal, but another sound field description, for example, using a Ambisonics encoder or calculator 430, then the distance modification
35 can also be performed subsequent to the generation in block 1260, which means in block 1270c. Depending on the implementation, a distance modification can also be distributed to several modifiers so that, in the end, a certain sound source is in a certain loudness that is directed by the difference between the original distance between the sound source and the reference location and the new distance between the sound source and the different reference location.

Fig. 12a illustrates a DirAC analyzer as originally disclosed, for example, in the earlier cited reference "Directional Audio Coding" from IWPASH of 2009.

The DirAC analyzer comprises a bank of band filters 1310, an energy analyzer 1320, an intensity analyzer 1330, a temporal averaging block 1340 and a diffuseness calculator 1350 and the direction calculator 1360.

5

In DirAC, both analysis and synthesis are performed in the frequency domain. There are several methods for dividing the sound into frequency bands, within distinct properties each. The most commonly used frequency transforms include short time Fourier transform (STFT), and Quadrature mirror filter bank (QMF). In addition to these, there is a full liberty to design a filter bank with arbitrary filters that are optimized to any specific purposes. The target of directional analysis is to estimate at each frequency band the direction of arrival of sound, together with an estimate if the sound is arriving from one or multiple directions at the same time. In principle, this can be performed with a number of techniques, however, the energetic analysis of sound field has been found to be suitable, which is illustrated in Fig. 12a. The energetic analysis can be performed, when the pressure signal and velocity signals in one, two or three dimensions are captured from a single position. In first-order B-format signals, the omnidirectional signal is called W-signal, which has been scaled down by the square root of two. The sound pressure can be estimated as $P = \sqrt{2} * W$, expressed in the STFT domain.

10
15
20

The X-, Y- and Z channels have the directional pattern of a dipole directed along the Cartesian axis, which form together a vector $U = [X, Y, Z]$. The vector estimates the sound field velocity vector, and is also expressed in STFT domain. The energy E of the sound field is computed. The capturing of B-format signals can be obtained with either coincident positioning of directional microphones, or with a closely-spaced set of omnidirectional microphones. In some applications, the microphone signals may be formed in a computational domain, i.e., simulated.

The direction of sound is defined to be the opposite direction of the intensity vector I. The direction is denoted as corresponding angular azimuth and elevation values in the transmitted meta data. The diffuseness of sound field is also computed using an expectation operator of the intensity vector and the energy. The outcome of this equation is a real-valued number between zero and one, characterizing if the sound energy is arriving from a single direction (diffuseness is zero), or from all directions (diffuseness is one). This procedure is appropriate in the case when the full 3D or less dimensional velocity information is available.

25
30
35

Fig. 12b illustrates a DirAC synthesis, once again having a bank of band filters 1370, a virtual microphone block 1400, a direct/diffuse synthesizer block 1450, and a certain loudspeaker setup or a virtual intended loudspeaker setup 1460. Additionally, a diffuseness-gain transformer 1380, a vector based amplitude panning (VBAP) gain table block 1390, a microphone compensation block 1420, a loudspeaker gain averaging block 1430 and a distributor 1440 for other channels is used.

In this DirAC synthesis with loudspeakers, the high quality version of DirAC synthesis shown in Fig. 12b receives all B-format signals, for which a virtual microphone signal is computed for each loudspeaker direction of the loudspeaker setup 1460. The utilized directional pattern is typically a dipole. The virtual microphone signals are then modified in non-linear fashion, depending on the meta data. The low bitrate version of DirAC is not shown in Fig. 12b, however, in this situation, only one channel of audio is transmitted as illustrated in Fig. 6. The difference in processing is that all virtual microphone signals would be replaced by the single channel of audio received. The virtual microphone signals are divided into two streams: the diffuse and the non-diffuse streams, which are processed separately.

The non-diffuse sound is reproduced as point sources by using vector base amplitude panning (VBAP). In panning, a monophonic sound signal is applied to a subset of loudspeakers after multiplication with loudspeaker-specific gain factors. The gain factors are computed using the information of a loudspeaker setup, and specified panning direction. In the low-bit-rate version, the input signal is simply panned to the directions implied by the meta data. In the high-quality version, each virtual microphone signal is multiplied with the corresponding gain factor, which produces the same effect with panning, however it is less prone to any non-linear artifacts.

In many cases, the directional meta data is subject to abrupt temporal changes. To avoid artifacts, the gain factors for loudspeakers computed with VBAP are smoothed by temporal integration with frequency-dependent time constants equaling to about 50 cycle periods at each band. This effectively removes the artifacts, however, the changes in direction are not perceived to be slower than without averaging in most of the cases.

The aim of the synthesis of the diffuse sound is to create perception of sound that surrounds the listener. In the low-bit-rate version, the diffuse stream is reproduced by decorrelating the input signal and reproducing it from every loudspeaker. In the high-quality version, the virtual microphone signals of diffuse stream are already incoherent in

some degree, and they need to be decorrelated only mildly. This approach provides better spatial quality for surround reverberation and ambient sound than the low bit-rate version.

5 For the DirAC synthesis with headphones, DirAC is formulated with a certain amount of virtual loudspeakers around the listener for the non-diffuse stream and a certain number of loudspeakers for the diffuse steam. The virtual loudspeakers are implemented as convolution of input signals with a measured head-related transfer functions (HRTFs).

10 Although some aspects have been described in the context of an apparatus, it is clear that these aspects also represent a description of the corresponding method, where a block or device corresponds to a method step or a feature of a method step. Analogously, aspects described in the context of a method step also represent a description of a corresponding block or item or feature of a corresponding apparatus.

15 The inventive enhanced sound field description can be stored on a digital storage medium or a non-transitory storage medium or can be transmitted on a transmission medium such as a wireless transmission medium or a wired transmission medium such as the Internet.

20 Depending on certain implementation requirements, embodiments of the invention can be implemented in hardware or in software. The implementation can be performed using a digital storage medium, for example a floppy disk, a DVD, a CD, a ROM, a PROM, an EPROM, an EEPROM or a FLASH memory, having electronically readable control signals stored thereon, which cooperate (or are capable of cooperating) with a programmable computer system such that the respective method is performed.

25 Some embodiments according to the invention comprise a non-transitory data carrier having electronically readable control signals, which are capable of cooperating with a programmable computer system, such that one of the methods described herein is performed.

30 Generally, embodiments of the present invention can be implemented as a computer program product with a program code, the program code being operative for performing one of the methods when the computer program product runs on a computer. The program code may for example be stored on a machine readable carrier.

35

Other embodiments comprise the computer program for performing one of the methods described herein, stored on a machine readable carrier.

5 In other words, an embodiment of the inventive method is, therefore, a computer program having a program code for performing one of the methods described herein, when the computer program runs on a computer.

10 A further embodiment of the inventive methods is, therefore, a data carrier (or a digital storage medium, or a computer-readable medium) comprising, recorded thereon, the computer program for performing one of the methods described herein.

15 A further embodiment of the inventive method is, therefore, a data stream or a sequence of signals representing the computer program for performing one of the methods described herein. The data stream or the sequence of signals may for example be configured to be transferred via a data communication connection, for example via the Internet.

20 A further embodiment comprises a processing means, for example a computer, or a programmable logic device, configured to or adapted to perform one of the methods described herein.

A further embodiment comprises a computer having installed thereon the computer program for performing one of the methods described herein.

25 In some embodiments, a programmable logic device (for example a field programmable gate array) may be used to perform some or all of the functionalities of the methods described herein. In some embodiments, a field programmable gate array may cooperate with a microprocessor in order to perform one of the methods described herein. Generally, the methods are preferably performed by any hardware apparatus.

30

The above described embodiments are merely illustrative for the principles of the present invention. It is understood that modifications and variations of the arrangements and the details described herein will be apparent to others skilled in the art. It is the intent, therefore, to be limited only by the scope of the impending patent claims and not by the specific details presented by way of description and explanation of the embodiments herein.

35

References

- 5 [1] Liitola, T., *Headphone sound externalization*, Ph.D. thesis, Helsinki University of Technology. Department of Electrical and Communications Engineering Laboratory of Acoustics and Audio Signal Processing., 2006.
- [2] Blauert, J., *Spatial Hearing - Revised Edition: The Psychophysics of Human Sound Localization*, The MIT Press, 1996, ISBN 0262024136.
- 10 [3] Zhang, W., Samarasinghe, P. N., Chen, H., and Abhayapala, T. D., "Surround by Sound: A Re-view of Spatial Audio Recording and Reproduction," *Applied Sciences*, 7(5), p. 532, 2017.
- 15 [4] Bates, E. and Boland, F., "Spatial Music, Virtual Reality, and 360 Media," in *Audio Eng. Soc. Int. Conf. on Audio for Virtual and Augmented Reality*, Los Angeles, CA, U.S.A., 2016.
- [5] Anderson, R., Gallup, D., Barron, J. T., Kontkanen, J., Snavely, N., Esteban, C. H.,
20 Agarwal, S., and Seitz, S. M., "Jump: Virtual Reality Video," *ACM Transactions on Graphics*, 35(6), p. 198, 2016.
- [6] Merimaa, J., *Analysis, Synthesis, and Perception of Spatial Sound: Binaural Localization Modeling and Multichannel Loudspeaker Reproduction*, Ph.D. thesis, Helsinki
25 University of Technology, 2006.
- [7] Kronlachner, M. and Zotter, F., "Spatial Transformations for the Enhancement of Ambisonics Recordings," in *2nd International Conference on Spatial Audio*, Erlangen, Germany, 2014.
- 30 [8] Tsingos, N., Gallo, E., and Drettakis, G., "Perceptual Audio Rendering of Complex Virtual Environments," *ACM Transactions on Graphics*, 23(3), pp. 249–258, 2004.
- [9] Taylor, M., Chandak, A., Mo, Q., Lauterbach, C., Schissler, C., and Manocha, D.,
35 "Guided multi-view ray tracing for fast auralization," *IEEE Trans. Visualization & Comp. Graphics*, 18, pp. 1797– 1810, 2012.

- [10] Rungta, A., Schissler, C., Rewkowski, N., Mehra, R., and Manocha, D., "Diffraction Kernels for Interactive Sound Propagation in Dynamic Environments," *IEEE Trans. Visualization & Comp. Graphics*, 24(4), pp. 1613–1622, 2018.
- 5
- [11] Thiergart, O., Kowalczyk, K., and Habets, E. A. P., "An Acoustical Zoom based on Informed Spatial Filtering," in *Int. Workshop on Acoustic Signal Enhancement*, pp. 109–113, 2014.
- 10
- [12] Khaddour, H., Schimmel, J., and Rund, F., "A Novel Combined System of Direction Estimation and Sound Zooming of Multiple Speakers," *Radioengineering*, 24(2), 2015.
- [13] Ziegler, M., Keinert, J., Holzer, N., Wolf, T., Jaschke, T., op het Veld, R., Zakeri, F. S., and Foessel, S., "Immersive Virtual Reality for Live-Action Video using Camera
- 15
- Arrays," in *IBC*, Amsterdam, Netherlands, 2017.
- [14] Thiergart, O., Galdo, G. D., Taseska, M., and Habets, E. A. P., "Geometry-Based Spatial Sound Acquisition using Distributed Microphone Arrays," *IEEE Trans. Audio, Speech, Language Process.*, 21(12), pp. 2583–2594, 2013.
- 20
- [15] Kowalczyk, K., Thiergart, O., Taseska, M., Del Galdo, G., Pulkki, V., and Habets, E. A. P., "Parametric Spatial Sound Processing: A Flexible and Efficient Solution to Sound Scene Acquisition, Modification, and Reproduction," *IEEE Signal Process. Mag.*, 32(2), pp. 31–42, 2015.
- 25
- [16] Pulkki, V., "Spatial Sound Reproduction with Directional Audio Coding," *J. Audio Eng. Soc.*, 55(6), pp. 503–516, 2007.
- [17] International Telecommunication Union, "ITU-R BS.1534-3, Method for the subjective
- 30
- assessment of intermediate quality level of audio systems," 2015.
- [18] Thiergart, O., Del Galdo, G., Kuech, F., and Prus, M., "Three-Dimensional Sound Field Analysis with Directional Audio Coding Based on Signal Adaptive Parameter Estimators," in *Audio Eng. Soc. Conv. Spatial Audio: Sense the Sound of Space*,
- 35
- 2010.

[19] Kuttruff, H., *Room Acoustics*, Taylor & Francis, 4 edition, 2000.

[20] Borß, C., "A polygon-based panning method for 3D loudspeaker setups," in *Audio Eng. Soc. Conv.*, pp. 343–352, Los Angeles, CA, USA, 2014.

5

[21] Rummukainen, O., Schlecht, S., Plinge, A., and Habets, E. A. P., "Evaluating Binaural Reproduction Systems from Behavioral Patterns in a Virtual Reality – A Case Study with Impaired Binaural Cues and Tracking Latency," in *Audio Eng. Soc. Conv. 143*, New York, NY, USA, 2017.

10

[22] Engelke, U., Darcy, D. P., Mulliken, G. H., Bosse, S., Martini, M. G., Arndt, S., Antons, J.-N., Chan, K. Y., Ramzan, N., and Brunnström, K., "Psychophysiology-Based QoE Assessment: A Survey," *IEEE Selected Topics in Signal Processing*, 11(1), pp. 6–21, 2017.

15

[23] Schlecht, S. J. and Habets, E. A. P., "Sign-Agnostic Matrix Design for Spatial Artificial Reverberation with Feedback Delay Networks," in *Proc. Audio Eng. Soc. Conf.*, pp. 1–10–accepted, Tokyo, Japan, 2018

20

[31] M. A. Gerzon, "Periphery: With-height sound reproduction," *J. Acoust. Soc. Am.*, vol. 21, no. 1, pp. 2-10, 1973.

[32] V. Pulkki, "Directional audio coding in spatial sound reproduction and stereo upmixing," in *Proc. of the 28th AES International Conference*, 2006.

25

[33] —, "Spatial sound reproduction with directional audio coding," *Journal Audio Eng. Soc.*, vol. 55, no. 6, pp. 503-516, Jun. 2007.

30

[34] C. G. and G. M., "Coincident microphone simulation covering three dimensional space and yielding various directional outputs," U.S. Patent 4 042 779, 1977.

[35] C. Faller and F. Baumgarte, "Binaural cue coding - part ii: Schemes and applications," *IEEE Trans. Speech Audio Process.*, vol. 11, no. 6, Nov. 2003.

35

[36] C. Faller, "Parametric multichannel audio coding: Synthesis of coherence cues," *IEEE Trans. Speech Audio Process.*, vol. 14, no. 1, Jan. 2006.

[37] H. P. J. E. E. Schuijers, J. Breebaart, "Low complexity parametric stereo coding," in *Proc. of the 116th AES Convention*, Berlin, Germany, 2004.

5 [38] V. Pulkki, "Virtual sound source positioning using vector base amplitude panning," *J. Acoust. Soc. Am.*, vol. 45, no. 6, pp. 456-466, Jun. 1997.

[39] J. G. Tylka and E. Y. Choueiri, "Comparison of techniques for binaural navigation of higher-order ambisonics sound fields," in *Proc. of the AES International*
10 *Conference on Audio for Virtual and Augmented Reality*, New York, Sep. 2016.

Claims

1. Apparatus for generating an enhanced sound field description, comprising:

5 a sound field generator for generating at least one sound field description indicating a sound field with respect to at least one reference location; and

a meta data generator for generating meta data relating to spatial information of the sound field,

10

wherein the at least one sound field description and the meta data constitute the enhanced sound field description.

2. Apparatus of claim 1,

15

wherein the sound field generator is configured to generate a first sound field description with respect to the reference location and a second sound field description with respect to a further reference location, the further reference location being different from the reference location, and

20

wherein the meta data generator is configured to determine the reference position and the further reference position individually or to determine a distance between the reference position and the further reference position or a location vector between the reference position and the further reference position as the meta data.

25

3. Apparatus of claim 2,

wherein the first sound field description is a first Ambisonics description, and wherein the second sound field description is a second Ambisonics description, or wherein the first sound field description and the second sound field description are one of an Ambisonics or a DirAC description.

30

4. Apparatus of one of the preceding claims,

wherein the first geometric description is an information on a first vector directed from a predetermined origin to a reference location of the first sound field description, and

5 wherein the second geometric description is an information on a second vector directed from the predetermined origin to a further reference location of a second sound field description.

10 5. Apparatus of one of the claims 1 to 4,

wherein the first geometric description is an information on one of a first vector directed from a predetermined origin to a reference location of a first sound field description and a second vector directed from the predetermined origin to a further reference location of a second sound field description, and an information on the vector between the reference location and the further reference location.

6. Apparatus of one of the claims 1 to 5,

20 wherein one of the reference location and the further reference location is a predetermined origin, and wherein the meta data comprises an information on the vector between the predetermined origin and the other of the reference location and the further reference location.

25 7. Apparatus of one of the claims 1 to 6, wherein the sound field generator is configured for generating the first sound field description or the second sound field description using a real microphone device or by a sound synthesis using a virtual microphone technique.

30 8. Apparatus for generating a modified sound field description from a sound field description and meta data relating to spatial information of the sound field description, comprising:

35 a sound field calculator for calculating the modified sound field using the spatial information, the sound field description and a translation information indicating a translation of a reference location to a different reference location.

9. Apparatus of claim 8,

wherein the sound field calculator is configured for calculating the modified sound field description using a signal-based translation method.

5

10. Apparatus of claim 8 or 9,

wherein the sound field calculator is configured

10

to receive a first sound field description related to the first reference location and to receive a second sound field description related to a further reference location being different from the reference location,

15

to perform a source separation to the first sound field description to obtain a first group of one or more extracted objects and the second sound field description to obtain a second group of one or more extracted objects,

to calculate direction of arrival (DoA) data for the extracted objects,

20

to match the first group of extracted objects of the first sound field description and the second group of extracted objects of the second sound field description,

25

to estimate a position of one or more matched objects, and

to modify one or more matched objects based on the estimated position of the matched object and the different reference location.

11. Apparatus of claim 10, wherein the sound field calculator is configured

30

to calculate direction of arrival data of the matched objects, and

to determine sound field description data for each matched object using the calculated direction of arrival data for the different reference locations.

35

12. Apparatus of one of claims 9 to 11,

wherein the sound field calculator is configured for calculating a sound field data for one or more non-matched objects using the direction of arrival data obtained for the non-matched objects.

5

13. Apparatus of one of claims 9 to 12,

wherein the sound field calculator is configured to calculate the modified sound field description by combining the sound field description data for the one or more matched objects and the one or more non-matched objects.

10

14. Apparatus of claim 8, wherein the sound field calculator configured to perform a parametric-based translation method.

15

15. Apparatus of claim 8 or claim 14,

wherein the sound field calculator is configured

to assume a sound field model,

20

to estimate signal components and/or parameters of the assumed sound field,

to modify the signal components and/or the parameters depending on the translation information or depending on the different reference location, and

25

to generate the modified sound field description using the modified signal components and/or the modified parameters.

30

16. Apparatus of claim 15,

wherein the sound field calculator is configured to estimate the signal components and/or the parameters using a decomposition of the sound field into one or more direct sound components and one or more diffuse sound components or by using a decomposition of the sound field into one or more direct/principal sound

35

components and a residual sound component, wherein the residual sound component can be a single-channel signal or a multi-channel signal.

17. Apparatus of one of claims 8 to 16,

5

wherein the sound field calculator is configured to apply a rotation of the modified sound field description.

18. Apparatus of one of claims 8 to 12,

10

wherein the modified sound field description is an Ambisonics sound field description.

19. Apparatus of one of claims 8 to 18, wherein the sound field calculator (420) is configured

15

to receive, as the sound field description, a first sound field description and a second sound field description,

20

to perform a source separation on the first and second sound field descriptions, to extract sources of the first and the second sound field descriptions and direction of arrival (DoA) data for extracted sources,

25

to calculate, for each extracted source, modified DoA data with respect to the different location using the DoA data and the translation information, and

to process the extracted sources and the modified DoA data to obtain the modified sound field description.

30 20. Apparatus of one of claims 8 to 19,

wherein the sound field calculator (420) is configured

35

to individually perform the source separation for each sound field description and to extract an ambience/diffuse/residual signal for each sound field description.

21. Apparatus of one of claims 8 to 20, further comprising:

5 a translation interface (410) for providing the translation information or rotation information indicating a rotation of an intended listener for the modified sound field;

a meta data supplier (402, 400) for supplying the meta data to the sound field calculator (420);

10 a sound field supplier (404, 400) for supplying the sound field description to the sound field calculator (420); and

15 an output interface (421) for outputting the modified sound field comprising the modified sound field description and modified meta data, the modified meta data being derived from the meta data using the translation information, or for outputting a plurality of loudspeaker channels, each loudspeaker channel being related to a predefined loudspeaker position, or for outputting a binaural representation of the modified sound field.

20 22. Apparatus of one of claims 8 to 21,

wherein the sound field description comprises a plurality of sound field components, the plurality of sound field components comprising an omnidirectional component and at least one directional component,

25

wherein the sound field calculator comprises:

a sound field analyzer (422) for analyzing the sound field components to derive, for different frequency bins, direction of arrival information;

30

a translation transformer (423) for calculating modified direction of arrival information per frequency bin using the direction information and meta data, the meta data comprising a depth map associating a distance information to a source represented by the frequency bin; and

35

a distance compensator for calculating the modified sound field using a distance compensation information depending on the distance provided by the depth map for the source, and a new distance associated with the frequency bin being related to the modified direction of arrival information.

5

23. Apparatus of one of claims 8 to 22, wherein the sound field calculator (420) is configured, for one or more sources,

10

for calculating (1104) a first vector pointing from the reference location to a sound source (510) obtained by the analysis (1102) of the sound field;

15

for calculating (1106) a second vector pointing from the different reference location (500) to the sound source (510) using the first vector and the translation information, the translation information defining a translation vector from the reference location (522) to the different reference location (500); and

20

for calculating (1106) a distance modification value using the different reference location (500), a location of the sound source (510), and the second vector, or using a distance from the different reference location (500) to the location of the sound source (510) and the second vector.

24. Apparatus of one of claims 8 to 23,

25

wherein a first vector is calculated by multiplying a direction of arrival unit vector by a distance included in the meta data, or

wherein a second vector is calculated by subtracting the translation vector from the first vector, or

30

wherein the distance modification value is calculated by dividing the second vector by a norm of the first vector.

25. Apparatus of one of claims 8 to 24,

35

wherein the sound field calculator (420) is configured to receive, in addition to the translation information, a rotation information, and

wherein the sound field calculator (420) is configured to perform a rotation transformation (424) to rotate a direction of arrival data for a sound field using the rotation information, wherein the direction of arrival data is derived from a direction of arrival data obtained by a sound field analysis of the sound field description and using the translation information.

5

26. Apparatus of one of claims 8 to 25, wherein the sound field calculator (420) is configured:

10

to determine (1200, 1240) sources from the sound field description and directions for the sources by a sound field analysis;

to determine (1220), for a source, a distance of the source from the reference location using the meta data;

15

to determine (1250) a new direction of the source related to the different reference location using the direction for the source and the translation information;

to determine (1230) a new distance information for the source related to the different reference location; and

20

to generate (1260) the modified sound field using the new direction of the source, the new distance information, and the sound field description or source signals corresponding to the sources derived from the sound field description.

25

27. Apparatus of one of claims 8 to 26, wherein the sound field calculator is configured:

to determine (1200) source signals from the sound field description and directions of the source signals related to the reference location by a sound analysis;

30

to calculate (1230) new directions of the source signals related to the different reference location using the translation information;

35

to calculate (1230) distance information for the sound sources related to the different reference location; and

5 to synthesize (1260) the modified sound field using the distance information, the source signals and the new directions.

28. Apparatus of claim 27, wherein the sound field calculator (420) is configured:

10 to synthesize the modified sound field by panning a sound source signal to a direction given by the new direction in relation to a replay setup, and

by scaling the sound source signal using the distance information before performing the panning or subsequent to performing the panning.

15 29. Apparatus of claim 27 or 28,

wherein the sound field calculator (420) is configured to add a diffuse signal to a direct part of the sound source signal, the direct part being modified by the distance information before being added to the diffuse signal.

20

30. Apparatus of one of claims 27 to 29, wherein the sound field calculator (420) is configured

25 to perform a time-frequency conversion of the sound field description and to calculate (422) a direction of arrival for a plurality of frequency bins of a time frame;

to calculate (423, 424) the new direction for each frequency bins,

to calculate the distance information for each frequency bin, and

30

to perform a direct synthesis for each frequency bin using an audio signal for a frequency bin, a panning gain for the frequency bin being derived from the new direction for the frequency bin and a scaling factor for the frequency bin derived from the distance information for the corresponding source.

35

31. Apparatus of claim 30, wherein the sound field calculator (420) is configured

to perform a diffuse synthesis using a diffuse audio signal derived from the audio signal for the frequency bin and using a diffuseness parameter derived by the sound analysis for the frequency bin and to combine the direct part and the diffuse part to obtain a synthesized audio signal for the frequency bin; and

to perform a frequency-time conversion using the audio signals for the frequency bins for a time frame to obtain a time domain synthesized audio signal as the modified sound field.

32. Apparatus of one of claims 27 to 31, wherein the sound field calculator (420) is configured to synthesize, for each sound source, a sound field related to the different reference location, the synthesis comprising:

for each source, processing (430) a source signal using the new direction for the source signal to obtain a sound field description of the source signal related to the different reference location;

modifying the source signal before processing the source signal or modifying the sound field description using the direction information; and

adding the sound field descriptions for the sources to obtain a modified sound field related to the different reference location.

33. Apparatus of one of claims 27 to 32,

wherein the sound analysis (1200) is configured to determine the source signals by a source separation algorithm and to subtract at least some of the source signals from the sound field description to obtain the diffuse signal.

34. Apparatus of one of claims 8 to 33,

wherein the sound field calculator (420) is configured determine a direction of arrival information for each matched source,

to determine a distance of a source to the new reference location using the direction of arrival information and the metadata for the at least one sound field description, and

5 to determine a scaling factor using the distance of the source to the new reference location.

35. Apparatus of one of claims 8 to 34, wherein the sound field calculator (420) is configured to

10

perform a sound analysis (700, 740, 741) to the sound field description to obtain a first group of one or more extracted objects or a direction of arrival information for one or more extracted objects and to a further sound field description related to a further reference location to obtain a second group of one or more extracted objects or a direction of arrival information for one or more extracted objects using the meta data;

15

to match (704) the first group and the second group using object signals from the groups or direction of arrival information for object from the groups to find at least one matched object;

20

to calculate (706, 746) an estimate position of the matched object using the meta data and a first direction of arrival information obtained for the matched object by performing the sound analysis to obtain the first group and a second direction of arrival information obtained for the matched object by performing the sound analysis to obtain the second group;

25

to apply (710, 748) a distance compensation processing to the matched object based on the estimated position and the translation information.

30

36. Apparatus of claim 35,

wherein the sound analysis is a DirAC analysis (740, 741) resulting in a signal for each time-frequency bin and the direction of arrival value for each time-frequency bin and an optional diffuseness value,

35

wherein the matching is performed for each individual time-frequency bin to determine at least one bin as the matched object, and

wherein an estimated position for the at least one bin is calculated (746).

5

37. Apparatus of claim 35,

wherein the sound analysis is a broadband source analysis (700) resulting in an extracted broadband signal and a direction of arrival information for the extracted broadband signal and, optionally, a diffuse signal,

10

wherein the source matching (704) is performed for the extracted broadband signals using a correlation measure for each pair of an extracted broadband signal from the first group and an extracted broadband signal from the second group, and

15

wherein the estimated position for the at least one matched broadband object is calculated (706).

38. Apparatus of one of claims 35 to 37,

20

wherein the sound field calculator (420) is configured to perform the calculation of the positions of the matched objects using a triangulation calculation receiving a first direction of arrival information derived from the sound field description and the second direction of arrival information derived from the further sound field description, and the meta data comprising information, from which an information on a vector between the reference location and the further reference location can be derived.

25

39. Apparatus of one of the preceding claims,

30

wherein the sound field calculator (420) is configured to select, for a calculation of a sound field description for a matched object related to the different reference location, either information related to the sound field description or related to the further sound field description depending on a distance of the reference location or the further reference location to a listener location determined by the translation information.

35

40. Apparatus of claim 39, wherein the sound field calculator is configured

5

to calculate (720) a first distance between the reference location and the new listener position;

to calculate (722) a second distance between the further reference location and the new listener position;

10

to select (724) the sound field description having a reference location that has the smaller distance from the first and the second distances.

41. Apparatus of one of claims 35 to 40,

15

wherein the sound field calculator is configured to calculate, for each matched object, a new direction of arrival information using one of the direction of arrival information derived from the sound field description and the further sound field description.

20

42. Apparatus of one of claims 40 or 41,

25

wherein the sound field calculator (420) is configured to calculate, for each matched object, a sound field description using the new direction of arrival information and to scale the source signal or the sound field description of the source signal using the estimated position of the matched object.

43. Apparatus of one of claims 35 to 42,

30

wherein the sound field calculator (420) is configured to calculate a sound field description for each non-matched object from the first group and to calculate a sound field description for each non-matched object from the second group using the corresponding direction of arrival information.

44. Apparatus of claim 43,

35

wherein the sound field calculator (420) is configured to calculate the modified sound field by combining (712) the sound field description of the matched objects and the sound field description of the non-matched objects.

5 45. Apparatus of one of claims 35 to 44,

wherein the sound field calculator (420) is configured to determine an information on a diffuse signal for at least one of the first group and the second group, and

10 wherein the sound field calculator is configured to add the diffuse signal to a sound field description of a matched object or a sound field description of a non-matched object.

46. Method of generating an enhanced sound field description, comprising:

15

generating at least one sound field description indicating a sound field with respect to at least one reference location; and

generating meta data relating to spatial information of the sound field,

20

wherein the at least one sound field description and the meta data constitute the enhanced sound field description.

47. Method of generating a modified sound field description from a sound field description and meta data relating to spatial information of the sound field description, the method comprising:

25

calculating the modified sound field using the spatial information, the sound field description and a translation information indicating a translation from a reference location to a different reference location.

30

48. Computer program for performing, when running on a computer or processor, the method of claim 46 or the method of claim 47.

35 49. Enhanced sound field description, comprising:

at least one sound field description indicating a sound field with respect to at least one reference location and meta data relating to spatial information of the sound field.

5 50. Enhanced sound field description of claim 49,

wherein the at least one sound field description comprises a first sound field description with respect to the reference location and a second sound field description with respect to a further reference location, the further reference
10 location being different from the reference location, and

wherein the meta data comprises the reference position and the further reference position individually or a distance between the reference position and the further reference position or a location vector between the reference position and the
15 further reference position or any information related to the reference position and the further reference position.

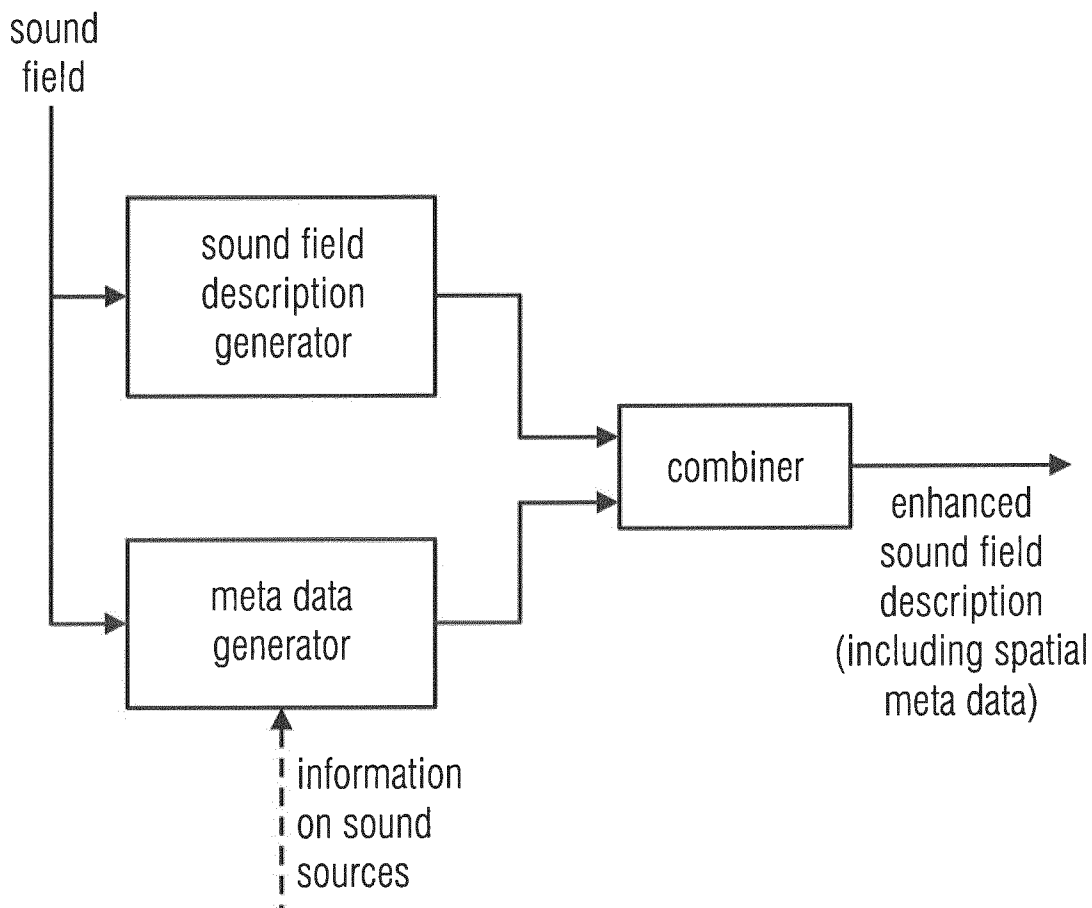

Fig. 1a

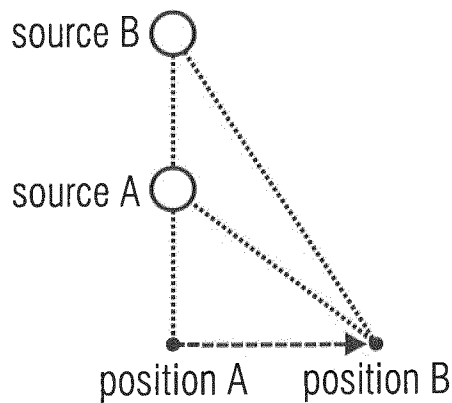

Fig. 1b

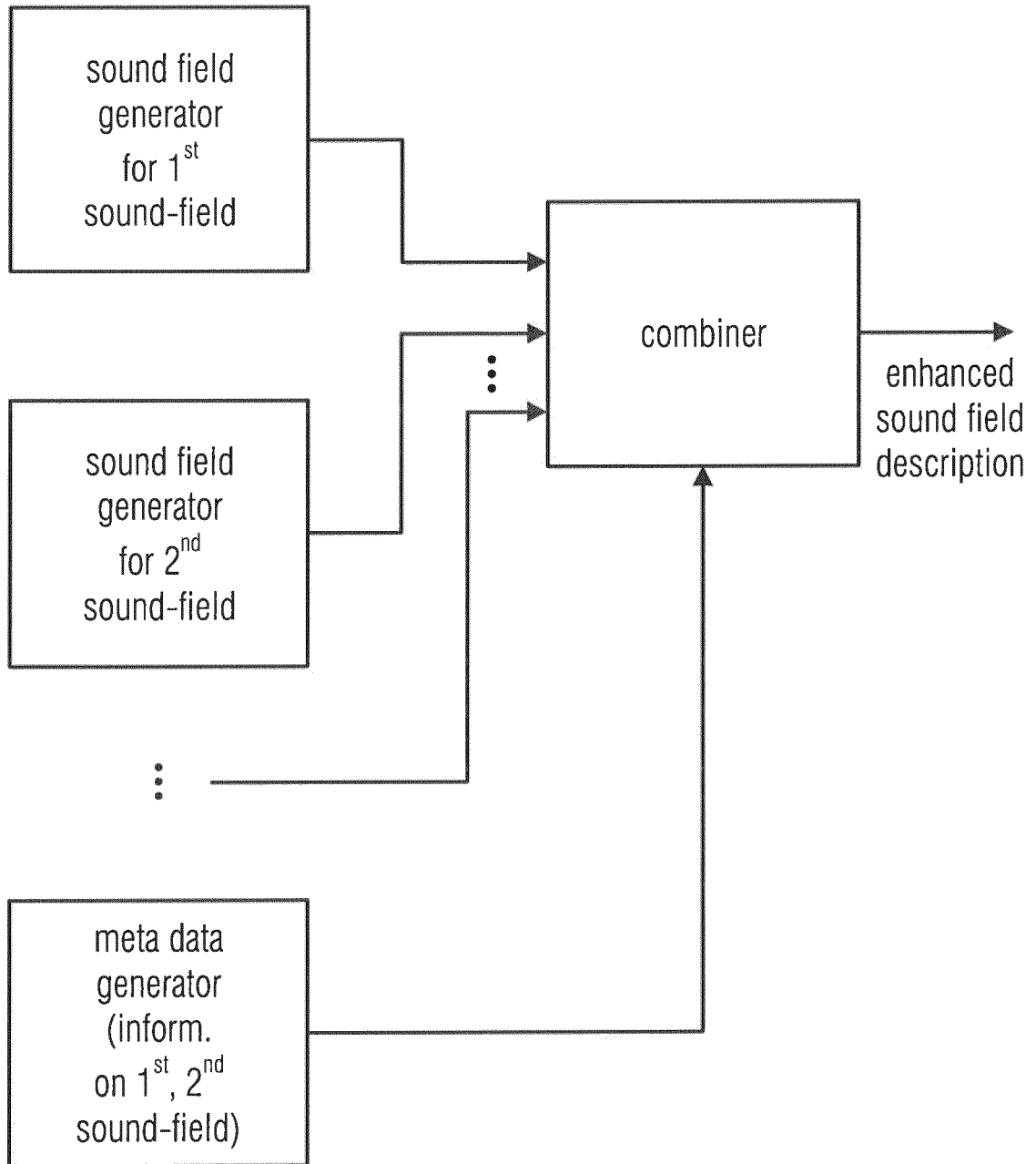

Fig. 2

	1 st sound-field description	2 nd sound-field description	information on 1 st and 2 nd sound fields
--	---	---	---

Fig. 3a

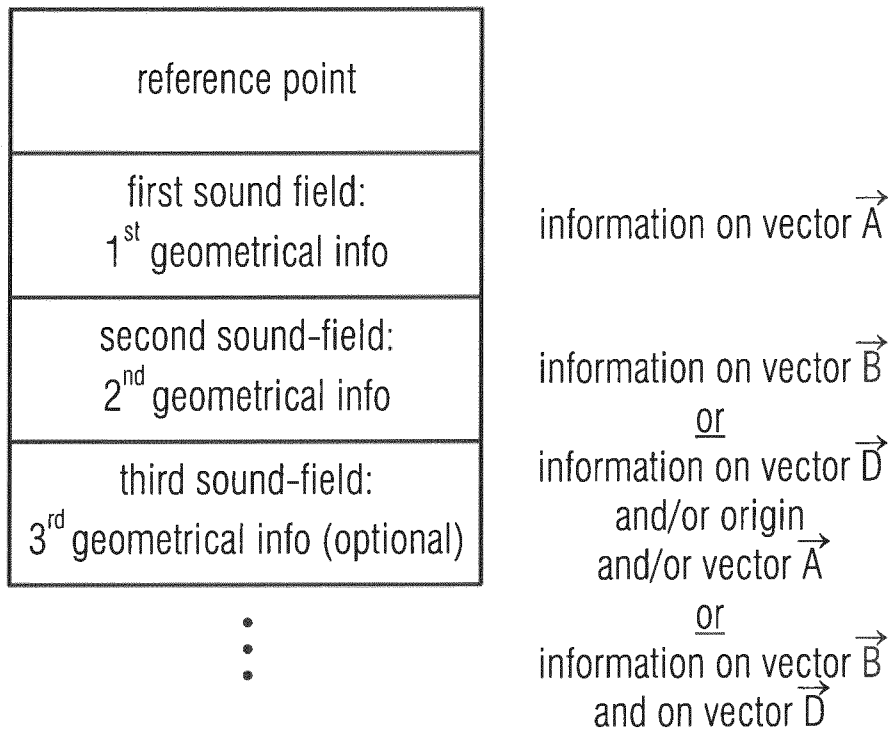

Fig. 3b

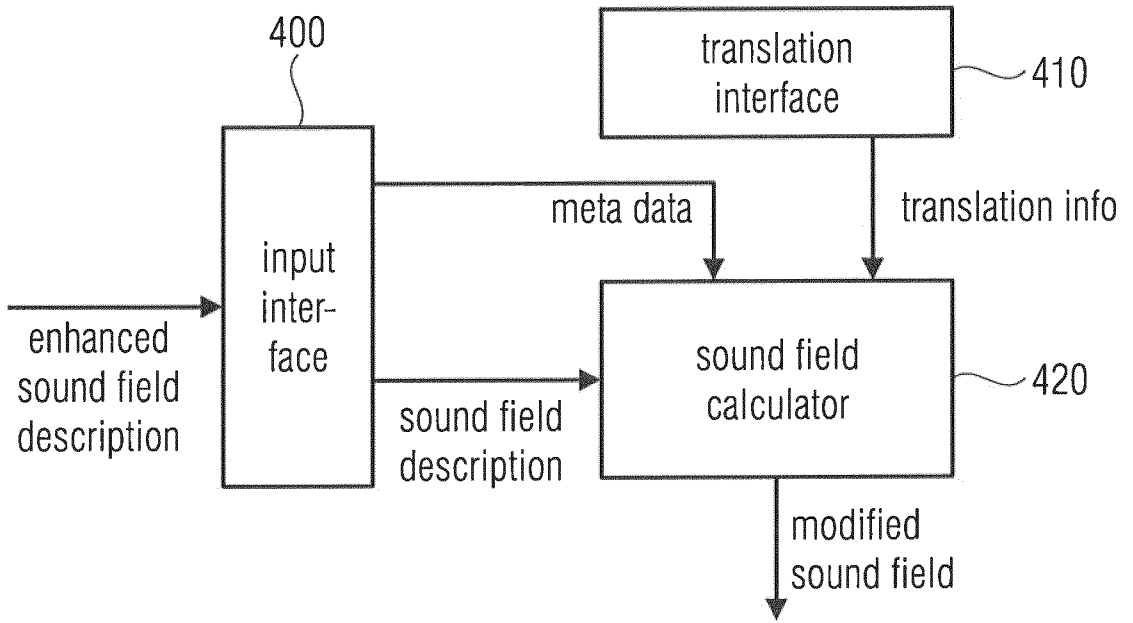

Fig. 4a

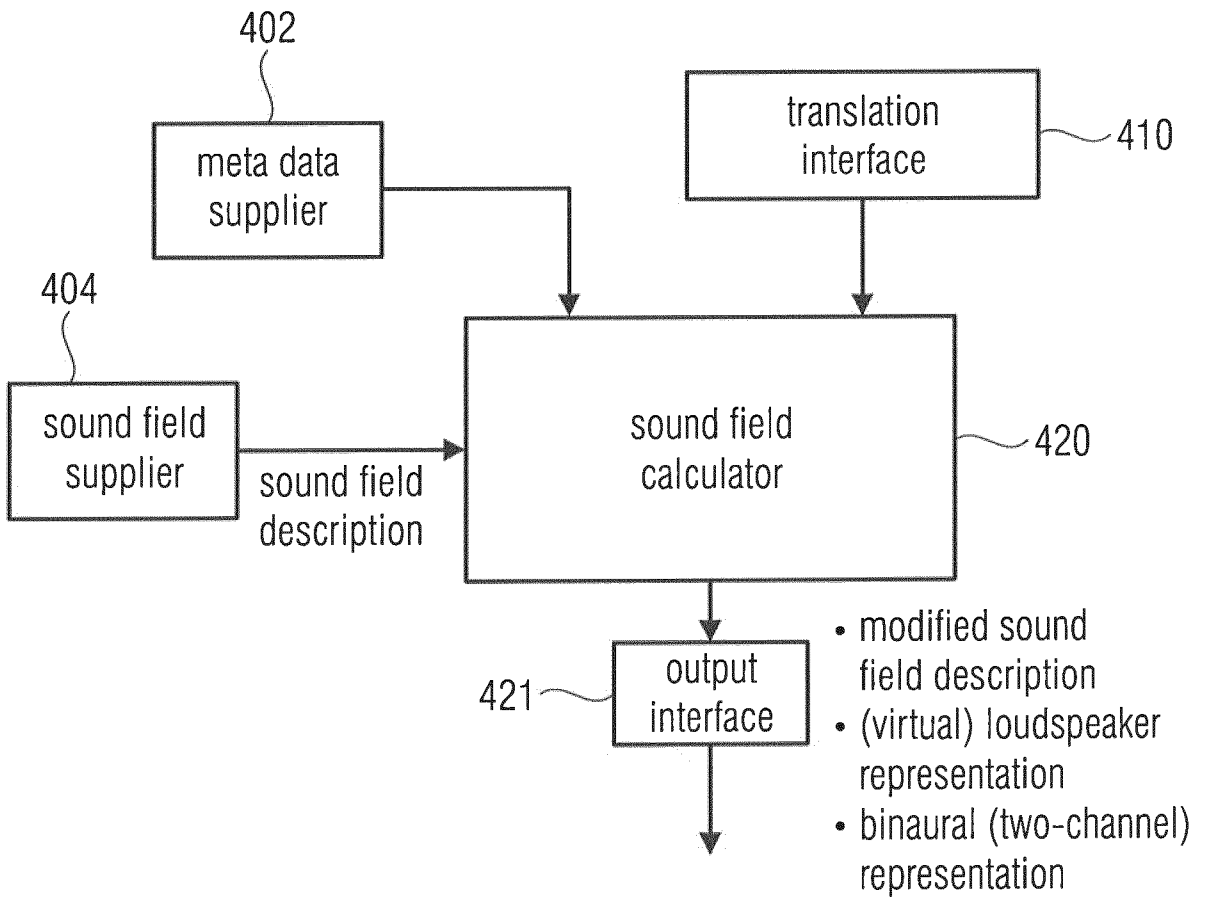

Fig. 4b

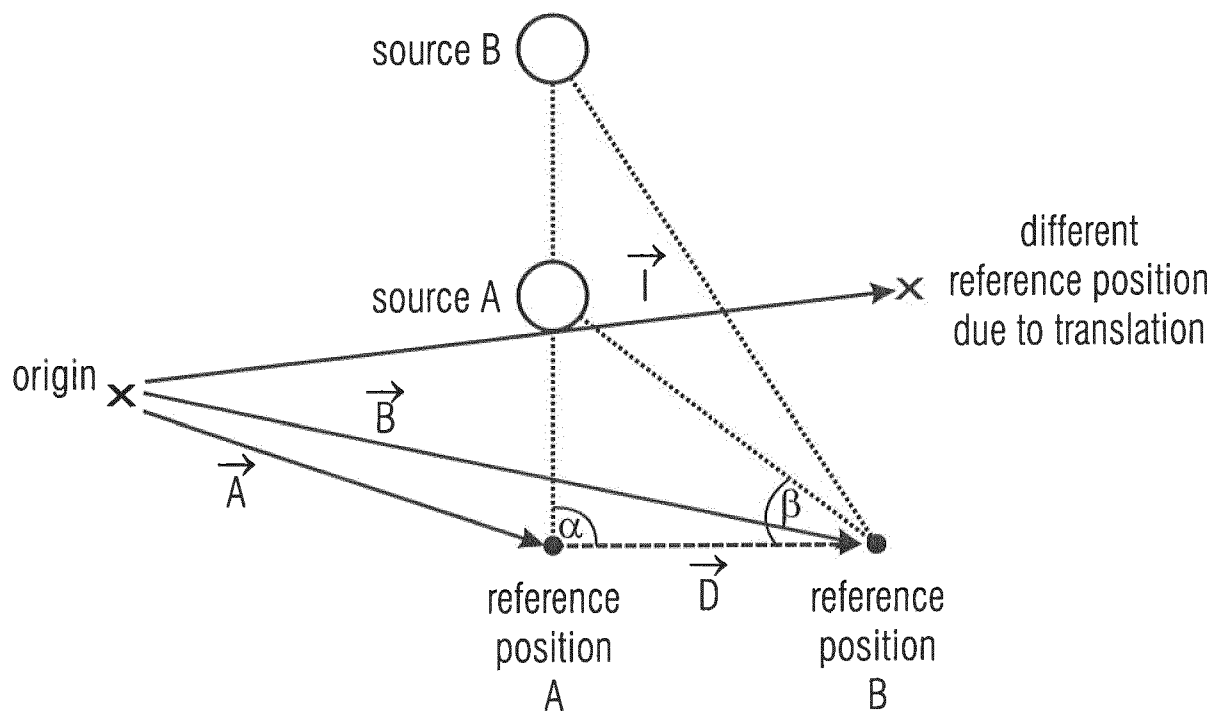

Fig. 4c

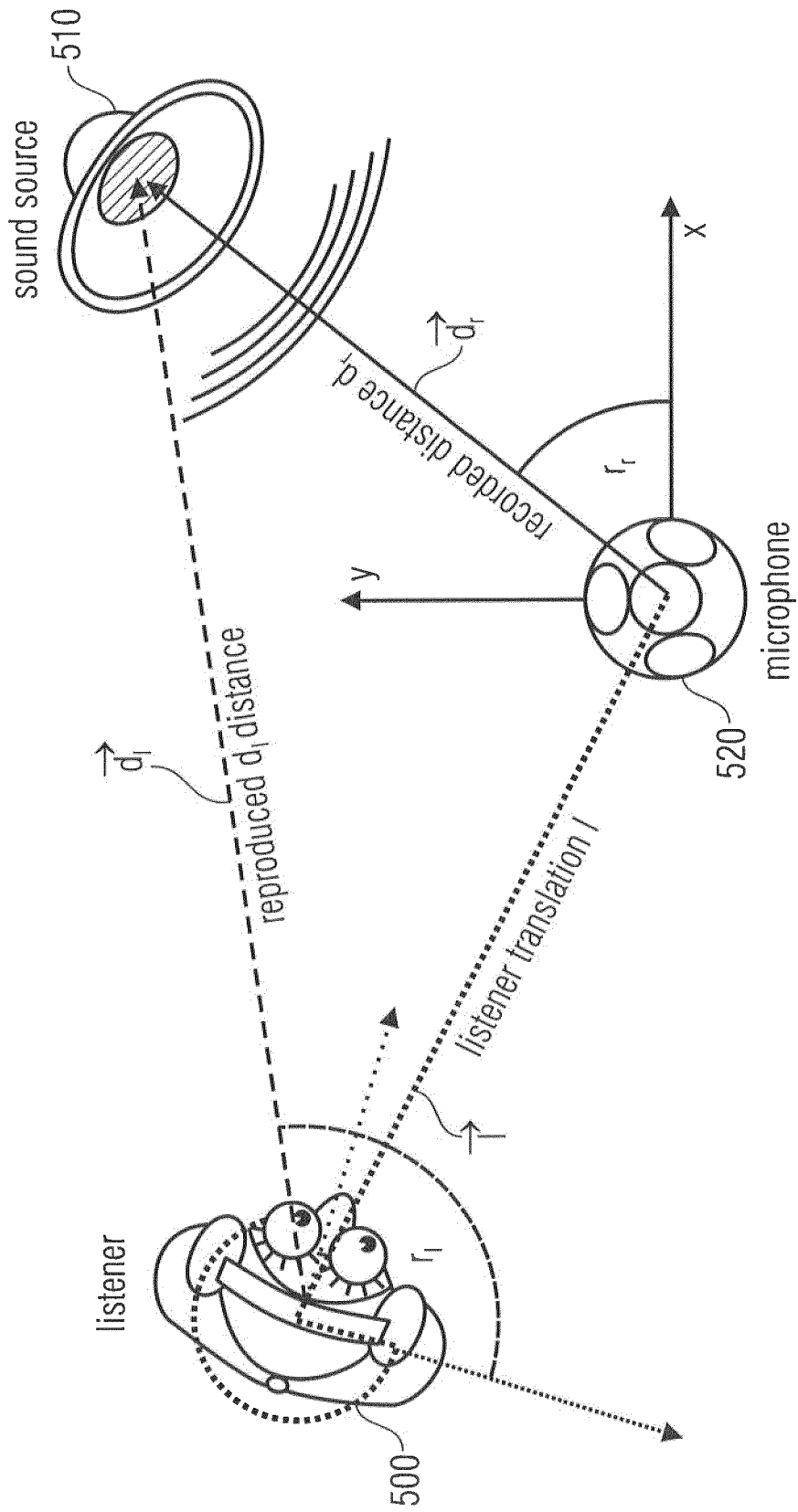

Fig. 5

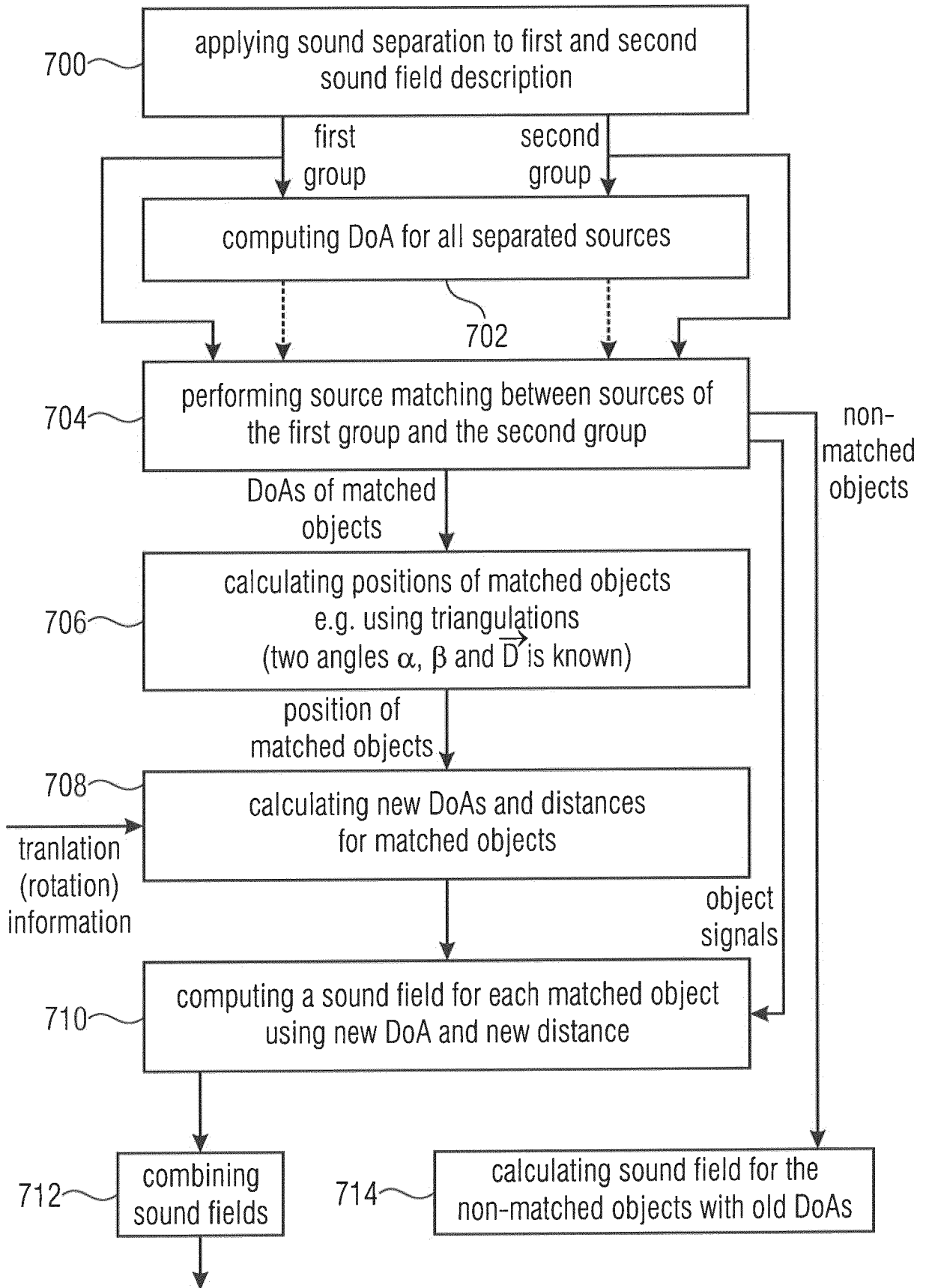

Fig. 6a

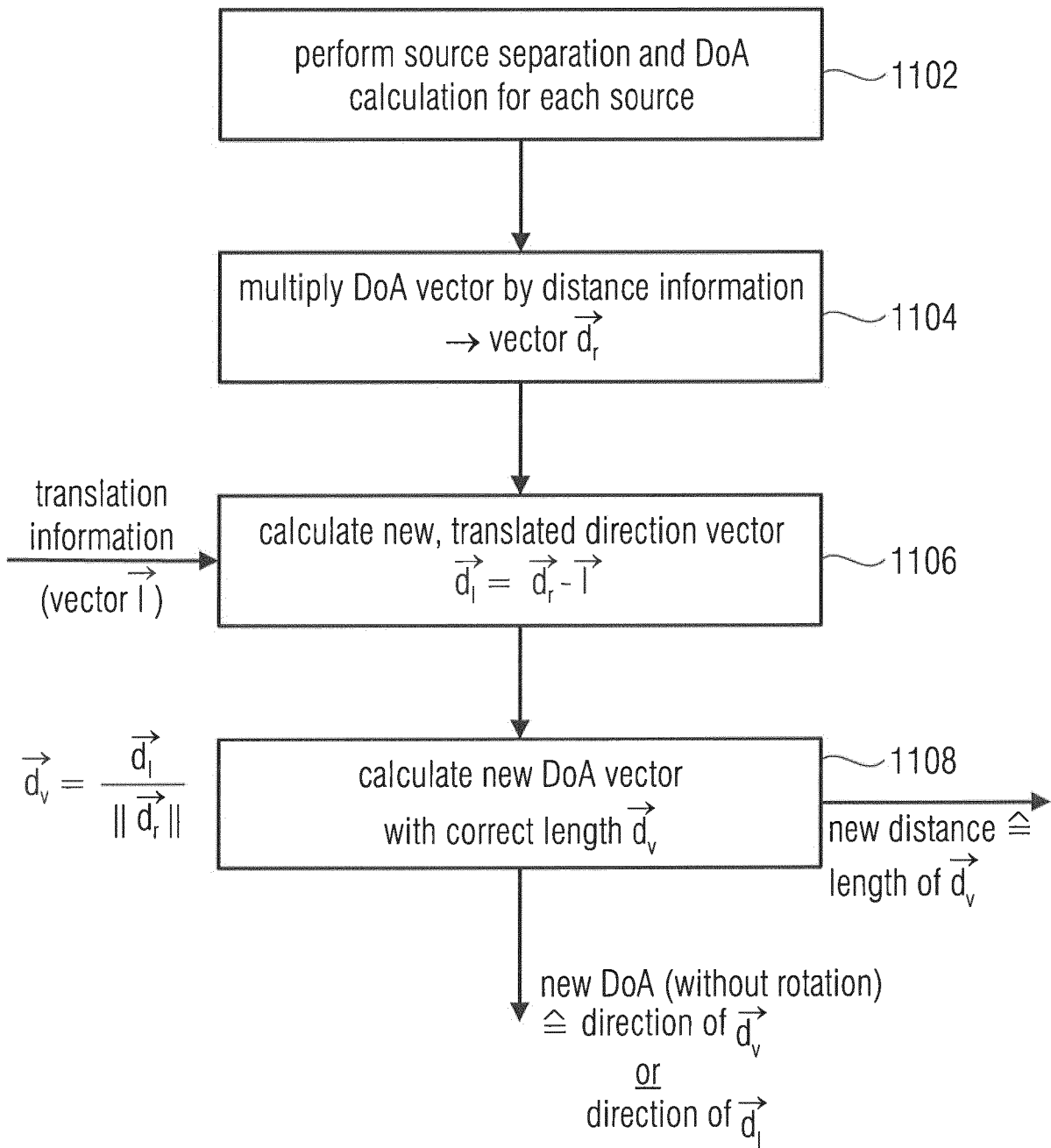

Fig. 6b

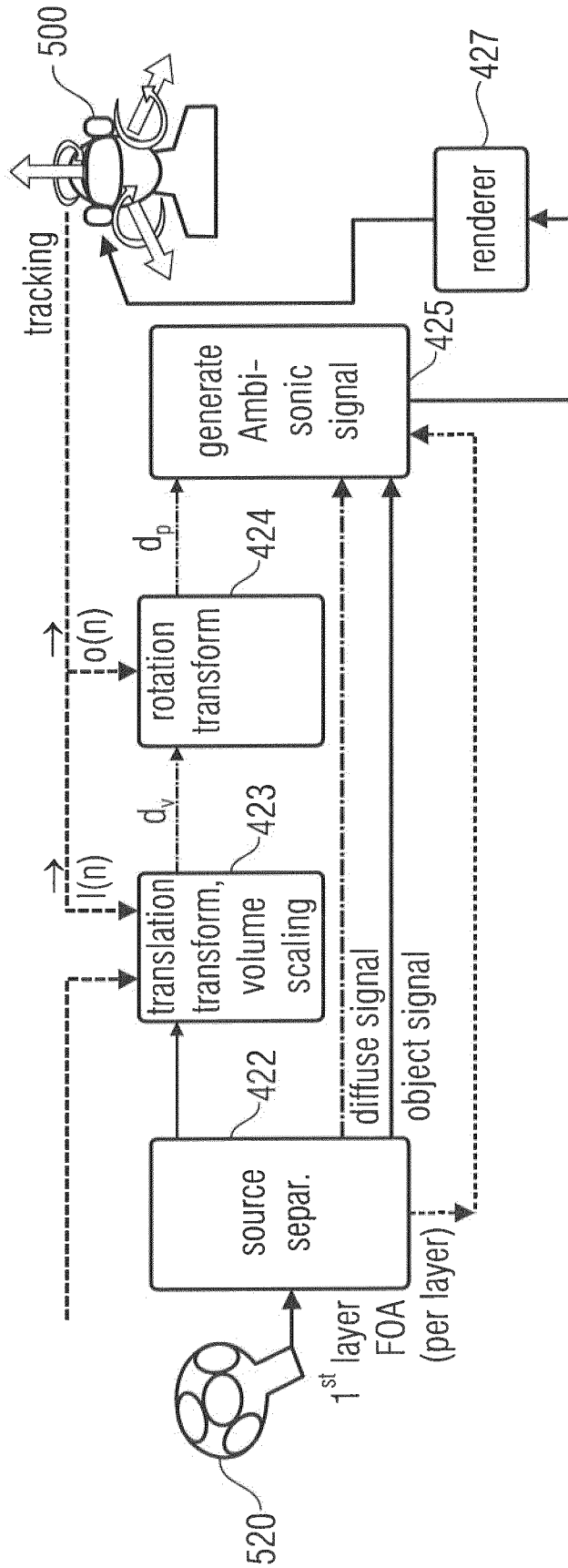

Fig. 6c

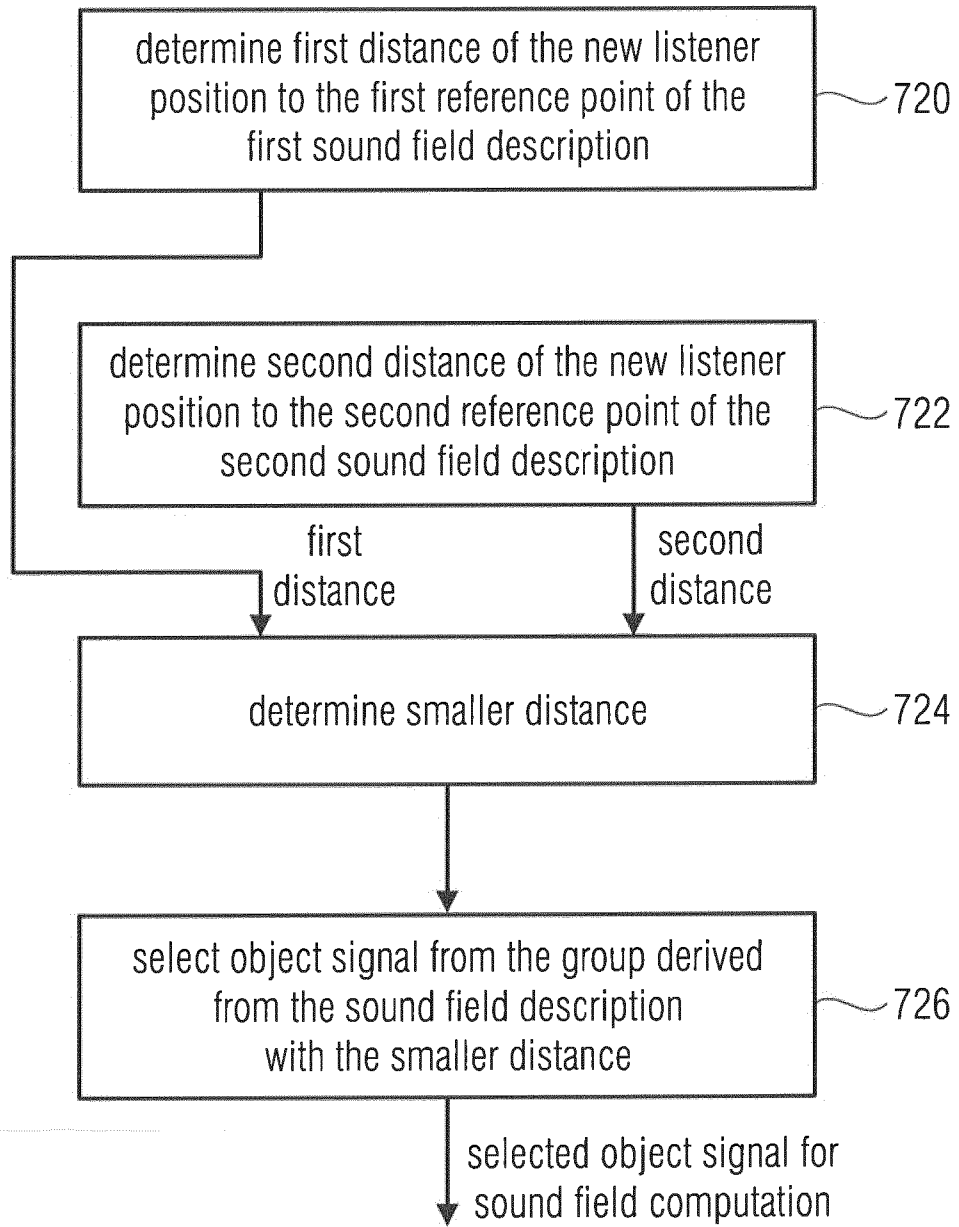
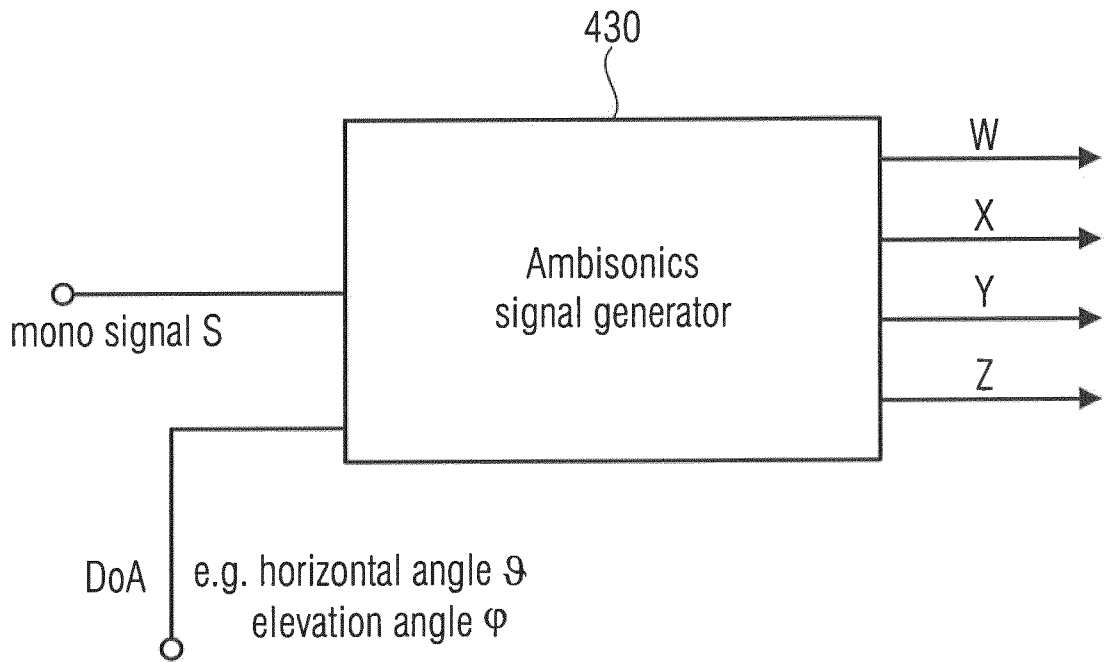

Fig. 7



omnidirectional comp $W = S \cdot \frac{1}{\sqrt{2}}$

directional components

$$\begin{cases} X = S \cdot \cos \Theta \cos \varphi \\ Y = S \cdot \sin \Theta \cos \varphi \\ Z = S \cdot \sin \varphi \end{cases}$$

Fig. 8

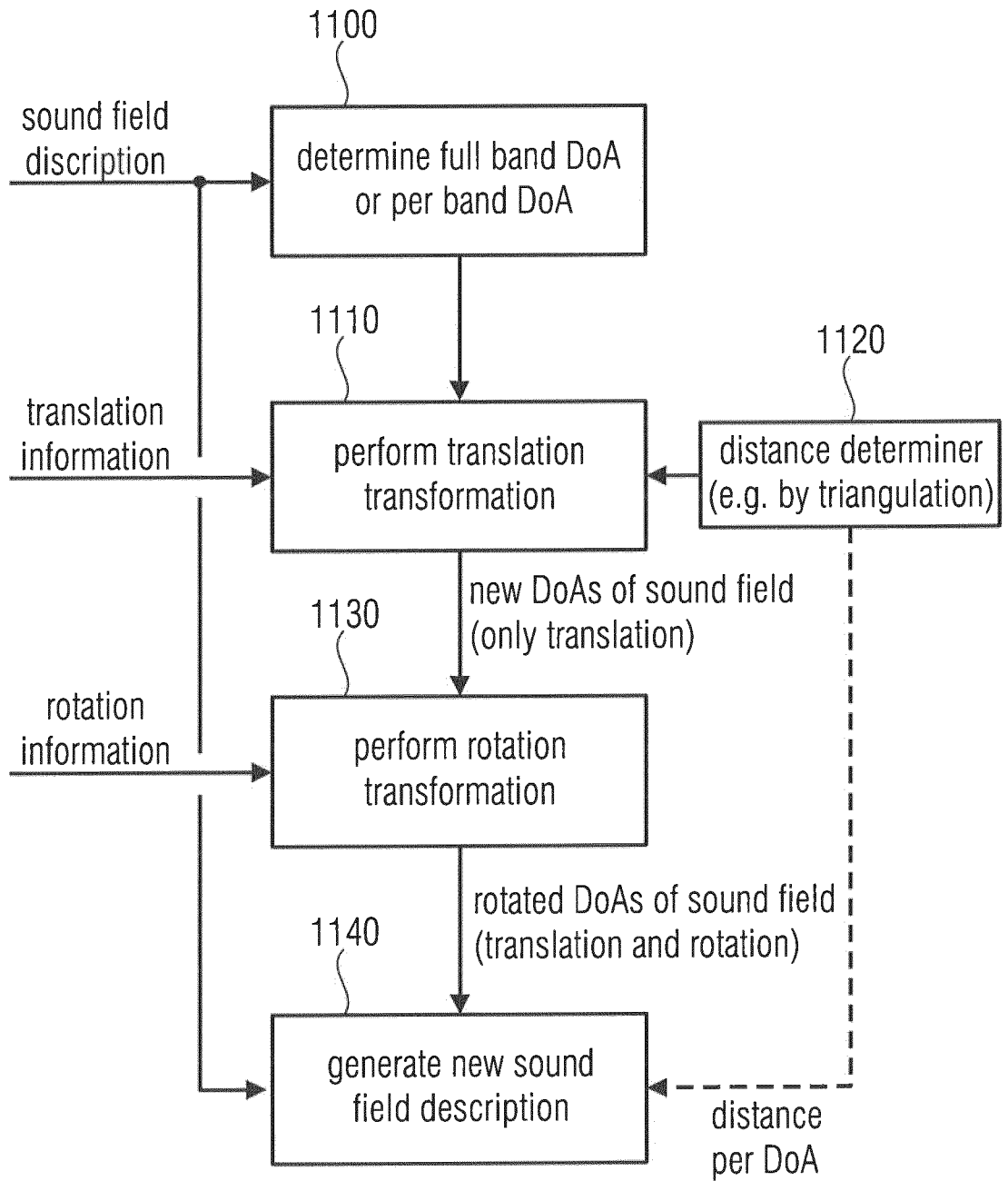

Fig. 10

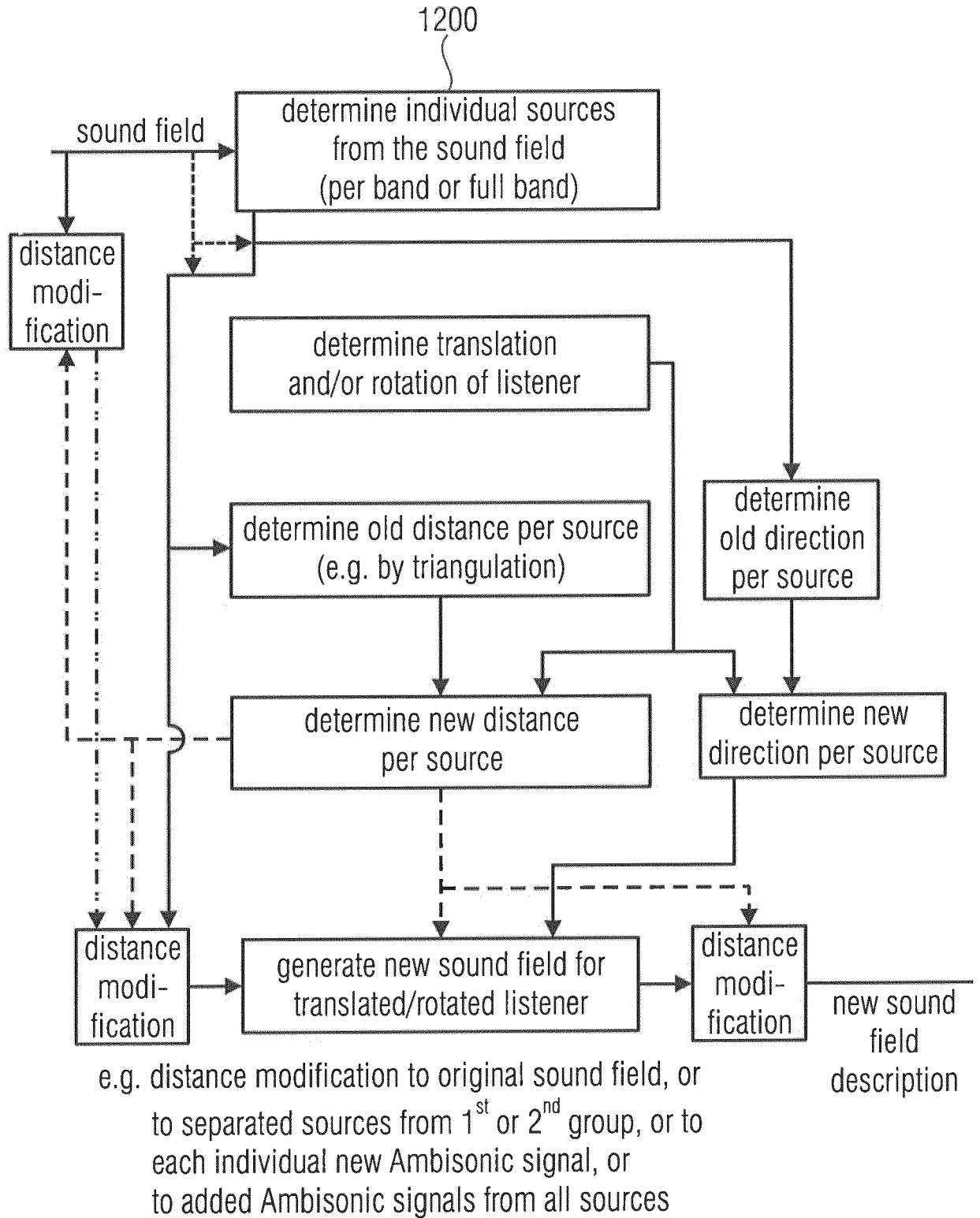
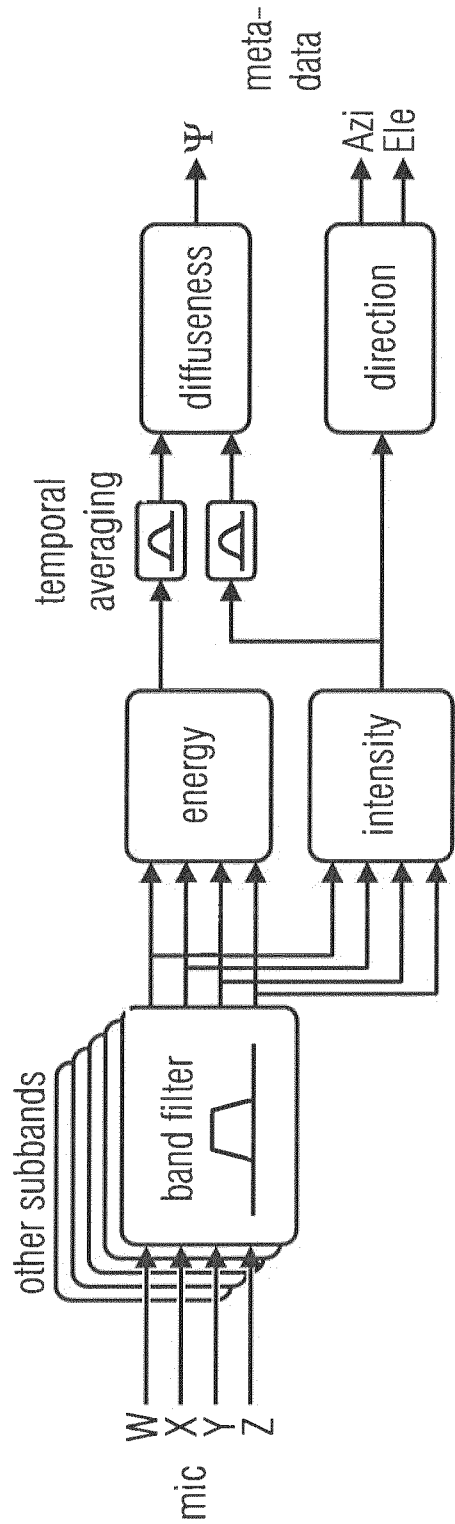
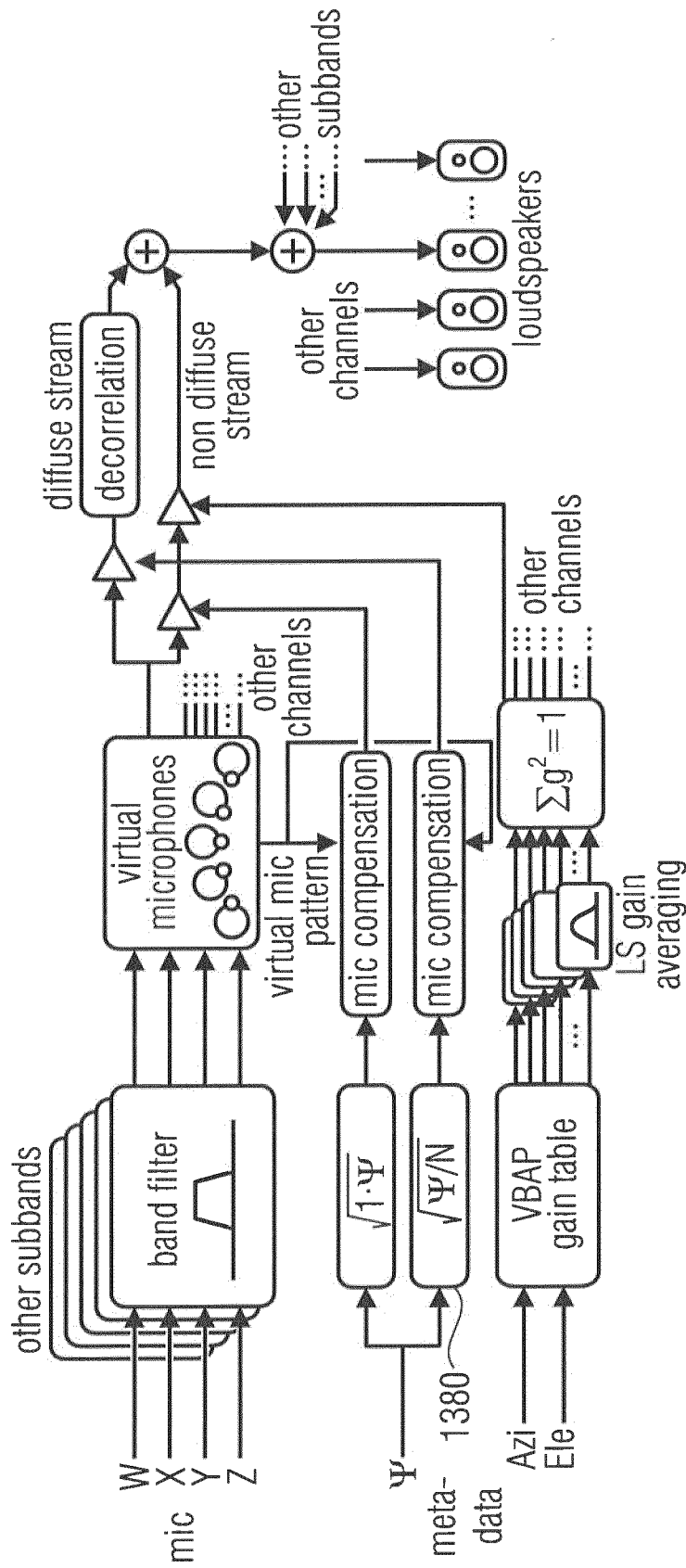

Fig. 11



DirAC analysis

Fig. 12a



DirAC synthesis

Fig. 12b

INTERNATIONAL SEARCH REPORT

International application No
PCT/EP2018/069140

A. CLASSIFICATION OF SUBJECT MATTER
 INV. G10L19/008 H04S7/00
 ADD. G06F3/01 G10L21/0272

According to International Patent Classification (IPC) or to both national classification and IPC

B. FIELDS SEARCHED

Minimum documentation searched (classification system followed by classification symbols)
 G10L G06F H04S

Documentation searched other than minimum documentation to the extent that such documents are included in the fields searched

Electronic data base consulted during the international search (name of data base and, where practicable, search terms used)
 EPO-Internal, WPI Data

C. DOCUMENTS CONSIDERED TO BE RELEVANT

Category*	Citation of document, with indication, where appropriate, of the relevant passages	Relevant to claim No.
X A	US 2013/216070 A1 (KEILER FLORIAN [DE] ET AL) 22 August 2013 (2013-08-22) paragraph [0011] - paragraph [0020] paragraph [0051] - paragraph [0064]; figures 3-5 paragraph [0109] - paragraph [0118] paragraph [0128] - paragraph [0129] ----- -/--	1-7,46, 48-50 8-45,47

Further documents are listed in the continuation of Box C.

See patent family annex.

* Special categories of cited documents :

"A" document defining the general state of the art which is not considered to be of particular relevance

"E" earlier application or patent but published on or after the international filing date

"L" document which may throw doubts on priority claim(s) or which is cited to establish the publication date of another citation or other special reason (as specified)

"O" document referring to an oral disclosure, use, exhibition or other means

"P" document published prior to the international filing date but later than the priority date claimed

"T" later document published after the international filing date or priority date and not in conflict with the application but cited to understand the principle or theory underlying the invention

"X" document of particular relevance; the claimed invention cannot be considered novel or cannot be considered to involve an inventive step when the document is taken alone

"Y" document of particular relevance; the claimed invention cannot be considered to involve an inventive step when the document is combined with one or more other such documents, such combination being obvious to a person skilled in the art

"&" document member of the same patent family

Date of the actual completion of the international search 20 September 2018	Date of mailing of the international search report 02/10/2018
--	--

Name and mailing address of the ISA/ European Patent Office, P.B. 5818 Patentlaan 2 NL - 2280 HV Rijswijk Tel. (+31-70) 340-2040, Fax: (+31-70) 340-3016	Authorized officer Virette, David
--	--

INTERNATIONAL SEARCH REPORT

International application No
PCT/EP2018/069140

C(Continuation). DOCUMENTS CONSIDERED TO BE RELEVANT		
Category*	Citation of document, with indication, where appropriate, of the relevant passages	Relevant to claim No.
X	US 2013/016842 A1 (SCHULTZ-AMLING RICHARD [DE] ET AL) 17 January 2013 (2013-01-17)	1,8, 14-18, 21-34, 46-49
A	paragraph [0003] - paragraph [0004] paragraph [0010] paragraph [0014] - paragraph [0019] paragraph [0033] paragraph [0041] paragraph [0048] paragraph [0099] - paragraph [0112]; figure 2	2-7, 9-13,19, 20,35-45
X	US 2013/142341 A1 (DEL GALDO GIOVANNI [DE] ET AL) 6 June 2013 (2013-06-06)	1,8,9, 17,18, 46-49
A	paragraph [0018] - paragraph [0019] paragraph [0034] paragraph [0047] paragraph [0092] - paragraph [0109]; figures 13-17 paragraph [0121] - paragraph [0127] paragraph [0141] paragraph [0166] paragraph [0228] paragraph [0234] - paragraph [0257] paragraph [0282] - paragraph [0284]; figures 29,31C	2-7, 10-16, 19-45,50
X	ROBERT L. BLEIDT ET AL: "Development of the MPEG-H TV Audio System for ATSC 3.0", IEEE TRANSACTIONS ON BROADCASTING., vol. 63, no. 1, March 2017 (2017-03), pages 202-236, XP055484143, US	1,46,48, 49
A	ISSN: 0018-9316, DOI: 10.1109/TBC.2017.2661258 page 203, paragraph II. A. - page 204 page 210, paragraph III. I. - page 212, paragraph IV. A. page 213, paragraph V. A. page 216, paragraph V. E. - page 217 page 225, paragraph VIII. B.	2-45,47, 50
	----- -/--	

INTERNATIONAL SEARCH REPORT

International application No
PCT/EP2018/069140

C(Continuation). DOCUMENTS CONSIDERED TO BE RELEVANT		
Category*	Citation of document, with indication, where appropriate, of the relevant passages	Relevant to claim No.
A	<p>TYLKA JOSEPH G ET AL: "Soundfield Navigation using an Array of Higher-Order Ambisonics Microphones", CONFERENCE: 2016 AES INTERNATIONAL CONFERENCE ON AUDIO FOR VIRTUAL AND AUGMENTED REALITY; SEPTEMBER 2016, AES, 60 EAST 42ND STREET, ROOM 2520 NEW YORK 10165-2520, USA, 21 September 2016 (2016-09-21), XP040681032, page 1, paragraph 1. - page 2 page 3, paragraph 2.2 page 4, paragraph 3.1 page 5, paragraph 3.3 -----</p>	1-50

INTERNATIONAL SEARCH REPORT

Information on patent family members

International application No

PCT/EP2018/069140

Patent document cited in search report	Publication date	Patent family member(s)	Publication date	
US 2013216070	A1	22-08-2013	AU 2011325335 A1	09-05-2013
			BR 112013010754 A2	02-05-2018
			CN 103250207 A	14-08-2013
			EP 2450880 A1	09-05-2012
			EP 2636036 A1	11-09-2013
			HK 1189297 A1	31-07-2015
			JP 5823529 B2	25-11-2015
			JP 2013545391 A	19-12-2013
			KR 20140000240 A	02-01-2014
			PT 2636036 E	13-10-2014
			US 2013216070 A1	22-08-2013
			WO 2012059385 A1	10-05-2012
			US 2013016842	A1
AU 2010332934 A1	26-07-2012			
CA 2784862 A1	23-06-2011			
CN 102859584 A	02-01-2013			
EP 2346028 A1	20-07-2011			
EP 2502228 A1	26-09-2012			
ES 2592217 T3	28-11-2016			
HK 1176733 A1	21-07-2017			
JP 5426035 B2	26-02-2014			
JP 2013514696 A	25-04-2013			
KR 20120089369 A	09-08-2012			
RU 2012132354 A	27-01-2014			
TW 201146026 A	16-12-2011			
US 2013016842 A1	17-01-2013			
WO 2011073210 A1	23-06-2011			
US 2013142341	A1	06-06-2013	AR 089053 A1	23-07-2014
			AU 2012343819 A1	24-07-2014
			AU 2016202604 A1	19-05-2016
			AU 2018200613 A1	08-02-2018
			CA 2857614 A1	06-06-2013
			CN 104185869 A	03-12-2014
			EP 2600343 A1	05-06-2013
			EP 2786374 A2	08-10-2014
			HK 1202181 A1	18-09-2015
			JP 6086923 B2	01-03-2017
			JP 2015502573 A	22-01-2015
			KR 20140097555 A	06-08-2014
			MX 342794 B	12-10-2016
			RU 2014126818 A	27-01-2016
			SG 11201402777Q A	27-06-2014
			TW 201334580 A	16-08-2013
US 2013142341 A1	06-06-2013			
WO 2013079663 A2	06-06-2013			
ZA 201404823 B	25-11-2015			