

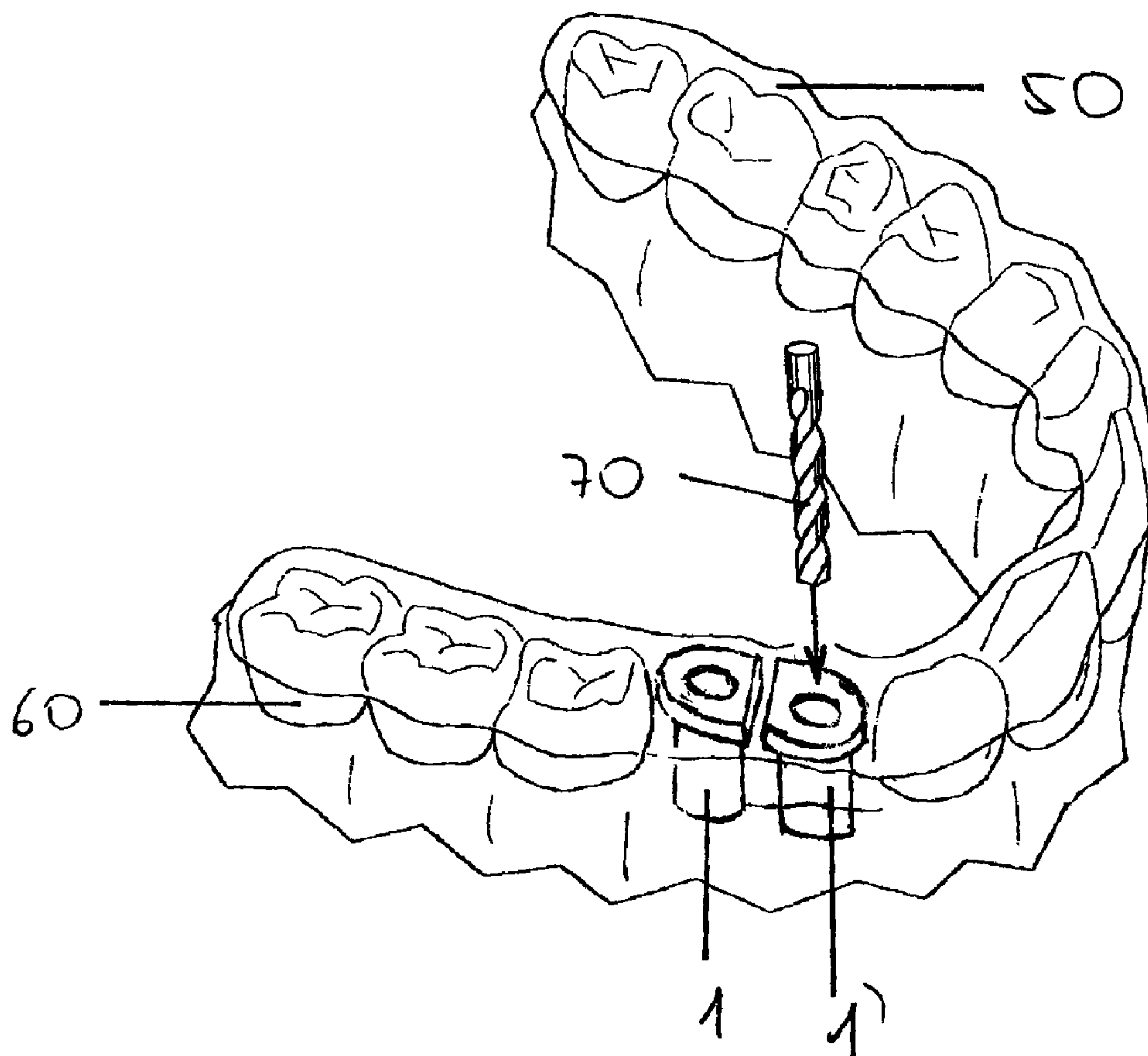

(22) Date de dépôt/Filing Date: 2009/11/30
(41) Mise à la disp. pub./Open to Public Insp.: 2010/06/01
(30) Priorité/Priority: 2008/12/01 (EP08 020 834.1)

(51) Cl.Int./Int.Cl. *A61C 1/08* (2006.01),
A61C 3/02 (2006.01)
(71) Demandeur/Applicant:
STRAUMANN HOLDING AG, CH
(72) Inventeurs/Inventors:
SUTER, EDMUND, CH;
KUEHNE, STEFFEN, CH;
STREFF, PATRICK, DE
(74) Agent: FETHERSTONHAUGH & CO.

(54) Titre : MANCHON DE FORET POUR FRAISE DENTAIRE
(54) Title: DRILL SLEEVE FOR A DENTAL DRILL



(57) Abrégé/Abstract:

The present invention pertains to a drill sleeve (1) for a dental drill (70). The drill sleeve (1) is essentially hollow cylindrical and has a longitudinal axis A, a circular inner surface (10) for guiding the dental drill (70), and an outer surface (15) intended to be inserted

(57) **Abrégé(suite)/Abstract(continued):**

into a template (50). The drill sleeve (1) is characterized in that the outer surface (15) of the drill sleeve (1) comprises at least one longitudinal flattened area (20), that the circular inner surface (10) is essentially parallel to the longitudinal axis A, and that the drill sleeve (1) is thin-walled.

Abstract

The present invention pertains to a drill sleeve (1) for a dental drill (70). The drill sleeve (1) is essentially hollow cylindrical and has a longitudinal axis A, a circular inner surface (10) for guiding the dental drill (70), and an outer surface (15) intended to be inserted into a template (50). The drill sleeve (1) is characterized in that the outer surface (15) of the drill sleeve (1) comprises at least one longitudinal flattened area (20), that the circular inner surface (10) is essentially parallel to the longitudinal axis A, and that the drill sleeve (1) is thin-walled.

(Fig. 4)

Drill sleeve for a dental drill

The present invention relates to a drill sleeve for a dental drill, to a set or template comprising the drill sleeve, and to its use for guiding a dental drill.

5 In dental treatment, it is well known to replace a missing tooth by an endosseous dental implant with an artificial crown. Typically, screw-shaped dental implants are used, such as the ones described by Brånemark in WO 97/49351. In order to anchor the implant in a patient's jaw-bone, a
10 suitable drill hole is applied to the bone and the dental implant is fixed therein.

When the drill hole is applied to the jaw-bone, it is very important that the position, depth, width, and orientation of the drill hole are accurately adjusted to the patient's
15 dental and osseous anatomy. A faulty drilling trajectory is very difficult to correct and can cause damage to nearby structures, such as the inferior alveolar nerve; it can also cause pain to the patient and, in some cases, even implant failure. In order to avoid deviations from
20 the optimal drilling position and orientation, it is known to use a custom-made surgical template having an exact mating region in the mouth of the patient (either on the jaw-bone, the gums or the remaining teeth), which has bore tubes with the predetermined positions and orientations.
25 Into these bore tubes, drill sleeves are inserted, which serve to guide the drills used for creating the implant drill holes in the jaw of the patient. Such a template with drill sleeves is described in US 5,015,183, WO 2006/041430, and WO 97/43981, for example.

- 2 -

The drill sleeves are typically of hollow cylindrical shape and made of metal. During the drilling process, the drill sleeve's circular inner surface serves as guidance for the drill. To this end, it is known to place a
5 secondary guiding element inside the drill sleeve, such as a drill spoon or a guiding cylinder, which can be exchanged in the course of the drilling process. The use of a drill sleeve in combination with a secondary guiding element is described in WO 2006/130067 or DE 10 2005 023
10 028, for instance. This approach is particularly favorable if several drills of increasing diameters are used for preparing the drill hole. Accordingly, several secondary guiding elements may be placed, one after the other, inside the same drill sleeve, each corresponding to a
15 certain drill diameter. Alternatively, it is also possible that the drill is guided directly by the drill sleeve itself.

For applying the drill hole to the patient's jaw-bone, the dental drill is inserted into the drill sleeve, optionally
20 containing a secondary guiding element, and then the hole is drilled in the axial direction of the drill sleeve. If the space above the implantation area is limited, especially in the case where a back tooth has to be replaced, it may be difficult to insert the drill axially
25 into the drill sleeve. In order to overcome this problem, drill sleeves having a longitudinal slit have been described in WO 2007/104842. With these slitted drill sleeves, it is possible to insert the drill sideways, which considerably facilitates the insertion of the drill
30 into the drill sleeve.

If, however, the space in the implantation area is limited in the lateral direction, especially if several adjacent

- 3 -

implants are to be placed within the same tooth gap, there may not be enough space to place all drills sleeves necessary within the gap. In addition, if two adjacent drill sleeves placed into the template are at close
5 quarters, the remaining template between the bore tubes for the drill sleeves may break. Accurate drilling of the drill hole can thus no longer be guaranteed.

It is therefore a problem of the present invention to provide a means for guiding a dental drill, which is
10 suitable for use in implantation areas with laterally limited space.

The problem is solved by the drill sleeves according to claim 1, the set according to claim 16, the template according to claim 18, and the use of the drill sleeve
15 according to claim 19. Preferred embodiments are subject to the dependent claims.

The drill sleeve of the present invention is essentially hollow cylindrical and comprises a longitudinal axis, a circular inner surface for guiding the dental drill, and
20 an outer surface intended to be inserted into a template. The drill sleeve is characterized by the fact that the outer surface of the drill sleeve comprises at least one longitudinal flattened area, whereas the inner surface of the drill sleeve has a circular cross section. In
25 addition, the circular inner surface of the drill sleeve is essentially parallel to the longitudinal axis, and the drill sleeve is thin-walled. Thus, the drill sleeve of the present invention has, in the at least one longitudinal flattened area, a smaller wall thickness than in the other
30 areas of the drill sleeve. The at least one longitudinal flattened area is oriented in the axial direction of the

drill sleeve and has a planar outer surface. The circular inner surface, which is intended to serve as a guide area for a dental drill, extends parallel to the longitudinal axis of the drill sleeve and thus also parallel to
5 circular part of the outer surface of the drill sleeve. In a preferred embodiment, the drill sleeve's coronal and apical end surfaces are at least essentially rectangular to the drill sleeve's longitudinal axis and thus also to its longitudinal flattened area and its circular inner
10 surface.

In addition, the wall thickness of the drill sleeve is as thin as possible: As space is typically rather limited in a patient's oral cavity, it is advantageous if the drill sleeve takes up as little space as possible. On the other
15 hand, the drill sleeve needs to have a certain minimal wall thickness in order to guarantee safe and reliable operation. The thin-walled drill sleeve of the present invention has, for instance, a wall thickness of about 0.2 to 1.5 mm, preferably of 0.4 to 1.3 mm.

20 In an alternative aspect of the present invention, the essentially hollow cylindrical drill sleeve comprises at least one longitudinal concave area, where the wall thickness is also smaller than in the other areas of the drill sleeve. The at least one longitudinal concave area
25 is oriented in the axial direction of the drill sleeve. Again, the thin-walled drill sleeve comprises a longitudinal axis and a circular inner surface for guiding the dental drill, which is essentially parallel to the longitudinal axis of the drill sleeve.

30 The drill sleeve of the present invention is suitable for being inserted into a bore tube in a surgical template

- 5 -

adjusted to a patient's mouth, thus defining a drilling trajectory. The circular inner of the drill sleeve is suitable for holding a secondary guiding element and/or for guiding a dental drill directly. Thanks to the at least one longitudinal flattened area in the outer surface, the drill sleeve requires less space and may be used in small tooth gaps with limited space.

In a preferred embodiment, the outer surface of the drill sleeve comprises exactly one longitudinal flattened area. Such a drill sleeve is especially well suited for gaps, into which two dental implants are to be placed: If each of the drill sleeves is oriented such that the two longitudinal flattened areas are facing each other, the distance between the two drill sleeves can be minimized without risking breakage of the interjacent template.

In another preferred embodiment, the outer surface of the drill sleeve comprises two longitudinal flattened areas. A drill sleeve having two flattened areas allows for a further minimization of the space required between one drill sleeve and a vicinal second drill sleeve or tooth. When inserting said drill sleeve into the template, it is particularly preferred to arrange the sleeve such that the two flattened areas are oriented in the direction of the vicinal second drill sleeves or teeth. Depending on the implantation position and the orientation of the surrounding teeth or implants, it may be most preferred that the two longitudinal flattened areas of the outer surface are diametrically opposed or that the two flattened areas are arranged in a certain angle.

In a preferred embodiment, the at least one longitudinal flattened or concave area is parallel to the longitudinal

- 6 -

axis of the drill sleeve. Such an orientation facilitates the insertion of the drill sleeve into a bore in a drill template.

In a preferred embodiment, the at least one longitudinal flattened or concave area extends over the full length of the drill sleeve, i.e. from its coronal end to its apical end surface. Again, this facilitates the insertion of the drill sleeve into a bore in a drill template.

In a preferred embodiment, the outer surface of the drill sleeve comprises a gripping surface. Such a gripping surface not only allows for safe handling of the drill sleeve before it is inserted into the template, but also improves the anchorage of the drill sleeve in the template. In a particularly preferred embodiment, the outer surface of the drill sleeve comprises several longitudinal projections in addition to the flattened area. These projections inhibit rotation of the drill sleeve during the drilling process, thus improving the accuracy of the drilling and minimizing the stress exerted on the template. In a particularly preferred embodiment, the longitudinal projections are interrupted by at least one essentially circular groove. By interaction of such a groove with a corresponding protrusion in the surrounding template, a vertical displacement of the drill sleeve within the template is inhibited. Alternatively, it is also possible that the outer surface of the drill sleeve is roughened in order to serve as a gripping surface.

In a preferred embodiment, the outer surface of the drill sleeve comprises a gripping surface in the form of longitudinal recesses and protrusions and at least one, preferably two, essentially circular grooves. Such an

- 7 -

embodiment is shown in Figure 2, for instance (see below). Such a drill sleeve may have, according to one preferred embodiment, an inner diameter of 5.0 mm, a minimal outer diameter of 5.7 mm, and a maximal outer diameter of 6.3 mm. According to another preferred embodiment, the drill sleeve has an inner diameter of 2.8 mm, a minimal outer diameter of 3.2 mm, and a maximal outer diameter of 3.8 mm. The height of these drill sleeves is preferably about 3 to 8 mm, more preferably about 5 to 6 mm, for instance 5 or 6 mm.

In a preferred embodiment of the present invention, the drill sleeve comprises a longitudinal slit. Such a slitted drill sleeve allows for inserting the drill sideways, which is particularly favorable if the space above the implantation area is limited and an axial insertion is difficult or even impossible. The longitudinal slit is preferably narrower than one third of the drill sleeve's circumference, in order to guarantee precise guiding of the drill. At the same time, the longitudinal slit is preferably wider than the diameter of the dental drill.

For drill sleeves having a longitudinal slit, it is particularly preferable that the rotation of the drill sleeve during the drilling process is inhibited. Therefore, it is preferred that a drill sleeve comprising a longitudinal slit also comprises a gripping surface, and, in particular, that the drill sleeve's outer surface comprises several longitudinal projections.

In a preferred embodiment, the drill sleeve comprises a circumferential flange at its coronal end. Thanks to such a circumferential flange, the fixation of the drill sleeve in the template is improved and, in particular, the drill

sleeve cannot be pushed further into the template during the drilling process. Therefore, greater stability of the template-drill sleeve assembly is achieved and the accuracy of the drilling can be maximized.

5 Preferably, the drill sleeve of the present invention is made of stainless steel. A drill sleeve of stainless steel is relatively inexpensive and guarantees precise guiding of the dental drill. In addition, it allows for facile sterilization in case the drill sleeve is used more than
10 once.

The present invention also relates to a set comprising one or more drill sleeves according to the present invention. Said set preferably comprises several drill sleeves, the drill sleeves' circular inner surfaces having differing
15 diameters and/or differing lengths. Such a set provides a choice of drill sleeves which may be chosen by the dental surgeon according to the patient's anatomy.

The present invention also relates to a template comprising one or more drill sleeves according to the
20 present invention.

The present invention also relates to the use of a drill sleeve according to the present invention for guiding a dental drill. The drill sleeve is preferably used in combination with a secondary guiding element inserted into
25 the drill sleeve. Alternatively, the drill may also be guided directly by the inner surface of the drill sleeve. The use of drill sleeve according to the present invention is particularly favorable if, in the lateral direction, the space around the implantation position is limited.

30

Embodiments of the invention will be described, by way of example only, with reference to the accompanying drawings, in which:

5 Fig. 1 shows a schematic representation of a first embodiment of the drill sleeve of the present invention;

Fig. 2 shows a schematic representation of a second embodiment of the drill sleeve of the present invention;

10 Fig. 3 shows a schematic representation of a third embodiment of the drill sleeve of the present invention; and

15 Fig. 4 shows a schematic representation of a template comprising two drill sleeves of the present invention.

The embodiment of the drill sleeve 1 shown in Figure 1 is of essentially hollow cylindrical shape and is entirely made of stainless steel. It has a longitudinal axis A, a circular inner surface 10 for guiding a drill, and an
20 outer surface 15, which is intended to be inserted into a template. The outer surface 15 as shown in Figure 1 comprises one longitudinal flattened area 20. However, it would also be possible that the outer surface 15 comprises more than one longitudinal flattened area 20. At its
25 coronal end 25, the drill sleeve 1 comprises a circumferential flange 30.

The embodiment of the drill sleeve 1 shown in Figure 2 also comprises a longitudinal axis A, a circular inner

- 10 -

surface 10, and an outer surface 15 with a longitudinal flattened area 20. In addition to the flattened area 20, the outer surface 15 also comprises several longitudinal projections 35, which are interrupted by an essentially
5 circular groove 40.

In the embodiment shown in Figure 3, the outer surface 15 of the drill sleeve 1 comprises two longitudinal flattened areas 20, 20', and, at its coronal end 25, a circumferential flange 30. This embodiment of the drill
10 sleeve 1 is further characterized by a longitudinal slit 45.

Figure 4 shows a schematic representation of a template 50, which is placed on a patient's dentition 60. The template 50 comprises two drill sleeves 1, 1' according to
15 the present invention, which are inserted into the template 50 at the implantation position. In order to prepare a drill hole in the patient's jaw-bone, the dental surgeon will insert a drill 70 through the drill sleeves 1, 1', using the drill sleeves 1, 1' as guidance for the
20 drill 70.

Claims

1. Drill sleeve (1) for a dental drill (70), the drill sleeve (1) being essentially hollow cylindrical and having a longitudinal axis, a circular inner surface (10) for guiding the dental drill (70) and an outer surface (15) intended to be inserted into a template (50), characterized in that the outer surface (15) of the drill sleeve (1) comprises at least one longitudinal flattened area (20), that the circular inner surface is essentially parallel to the longitudinal axis, and that the drill sleeve is thin-walled.
2. Drill sleeve (1) for a dental drill (70), the drill sleeve (1) being essentially hollow cylindrical and having a longitudinal axis, a circular inner surface (10) for guiding the dental drill (70) and an outer surface (15) intended to be inserted into a template (50), characterized in that the outer surface (15) of the drill sleeve (1) comprises at least one longitudinal concave area, that the circular inner surface is essentially parallel to the longitudinal axis, and that the drill sleeve is thin-walled.
3. Drill sleeve (1) according to claim 1, characterized in that its outer surface (15) comprises exactly one longitudinal flattened area (20).
4. Drill sleeve (1) according to claim 1, characterized in that its outer surface (15) comprises two longitudinal flattened areas (20, 20').

- 12 -

5. Drill sleeve (1) according to claim 4, characterized in that the two longitudinal flattened areas (20, 20') of the outer surface (15) are diametrically opposed.
- 5 6. Drill sleeve (1) according to one of claims 1 to 5, characterized in that the at least one longitudinal flattened or concave area is parallel to the longitudinal axis of the drill sleeve.
- 10 7. Drill sleeve (1) according to one of claims 1 to 6, characterized in that the at least one longitudinal flattened or concave area extends over the full length of the drill sleeve.
- 15 8. Drill sleeve (1) according to one of claims 1 to 7, characterized in that its outer surface (15) comprises a gripping surface.
9. Drill sleeve (1) according to claim 8, characterized in that its outer surface (15) additionally comprises several longitudinal projections (35).
- 20 10. Drill sleeve (1) according to claim 9, characterized in that the longitudinal projections (35) are interrupted by at least one essentially circular groove (40).
11. Drill sleeve (1) according to one of claims 1 to 10, characterized by a longitudinal slit (45).
- 25 12. Drill sleeve (1) according to claim 11, characterized in that the longitudinal slit (45) is narrower than one third of the drill sleeve's (1) circumference.

- 13 -

13. Drill sleeve (1) according to claim 11 or 12, characterized in that the longitudinal slit (45) is wider than the diameter of the dental drill (70).
14. Drill sleeve (1) according to one of claims 1 to 13,
5 characterized in that it comprises a circumferential flange (30) at its coronal end (25).
15. Drill sleeve (1) according to one of claims 1 to 14, characterized in that it is made of stainless steel.
16. Set comprising one or more drill sleeves (1, 1')
10 according to one of claims 1 to 15.
17. Set according to claim 16, characterized in that it comprises several drill sleeves (1, 1') according to one of claims 1 to 15 and that the drill sleeves' (1, 1') circular inner surfaces (10) have differing
15 diameters and/or differing lengths.
18. Template (50) comprising one or more drill sleeves (1, 1') according to one of claims 1 to 15.
19. Use of a drill sleeve (1) according to one of claims 1 to 15 for guiding a dental drill (70).

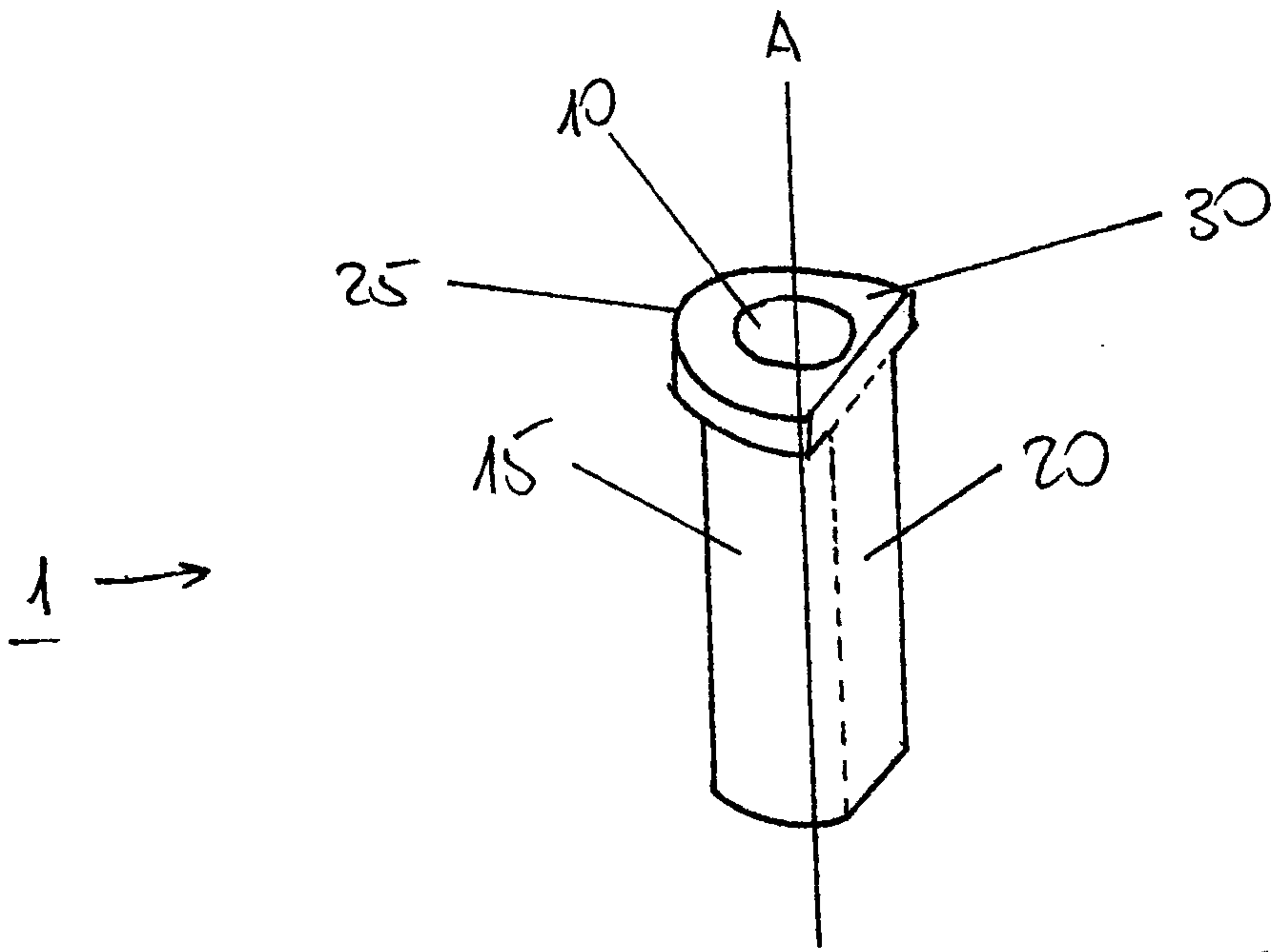

Fig. 1

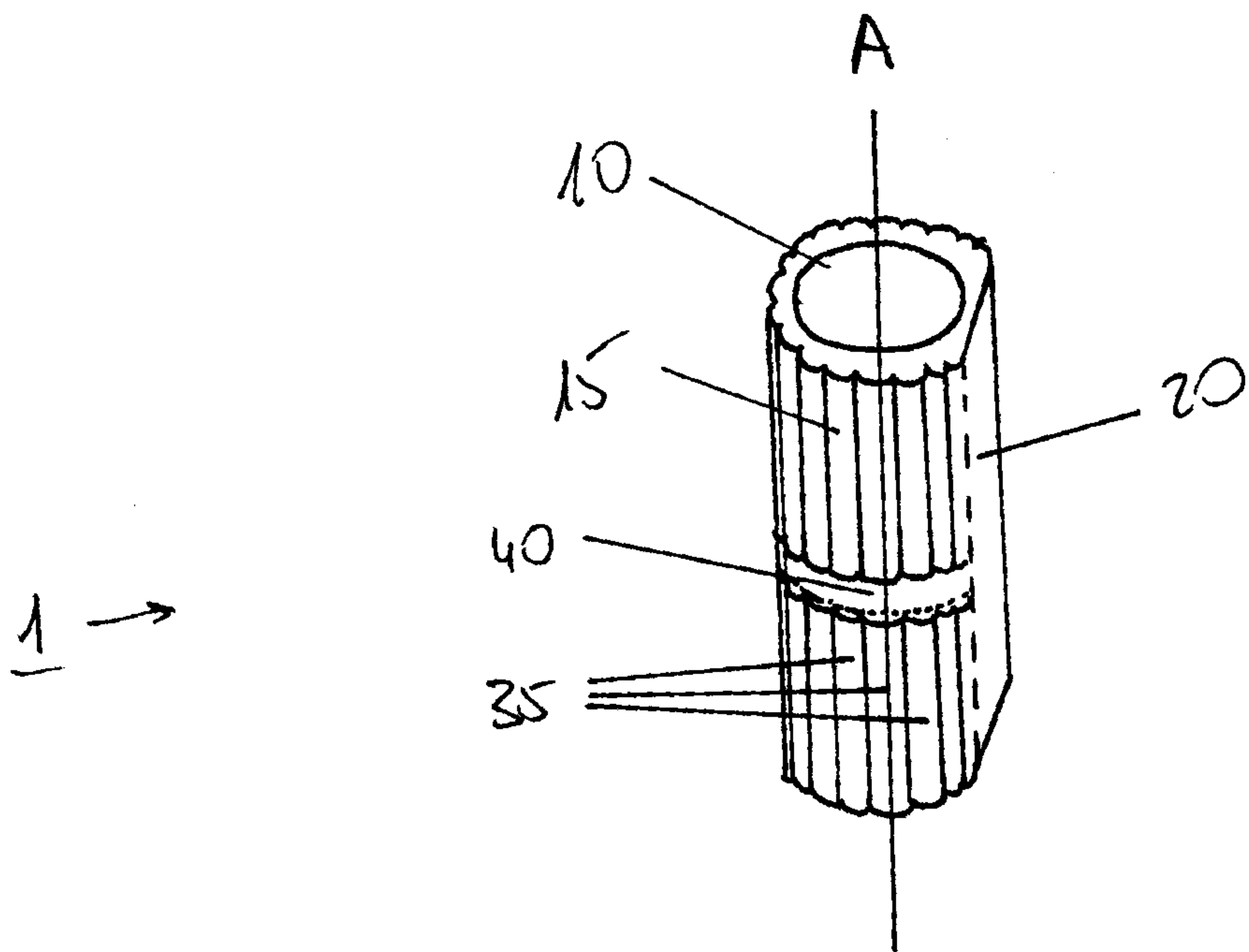

Fig. 2

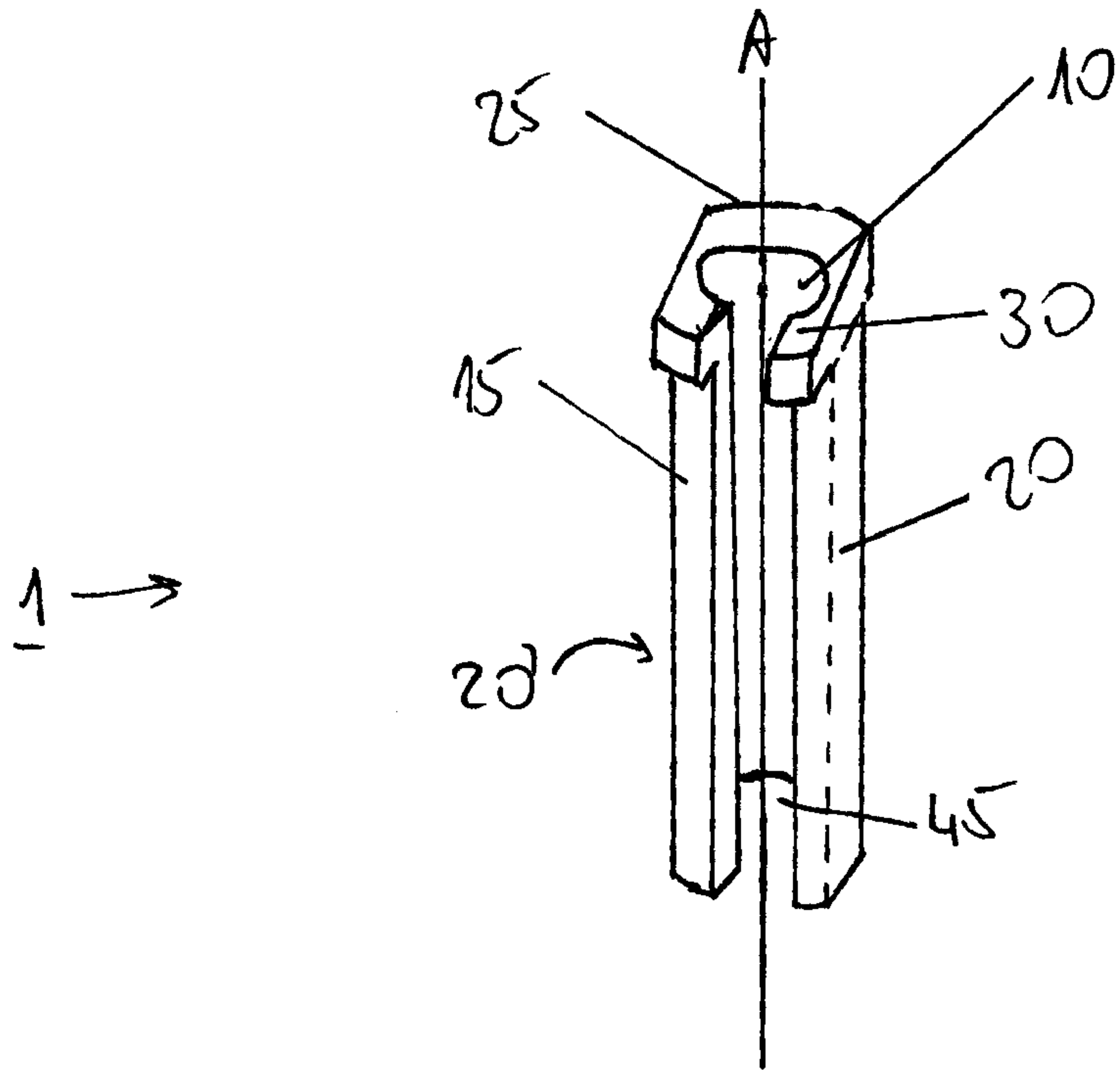

Fig. 3

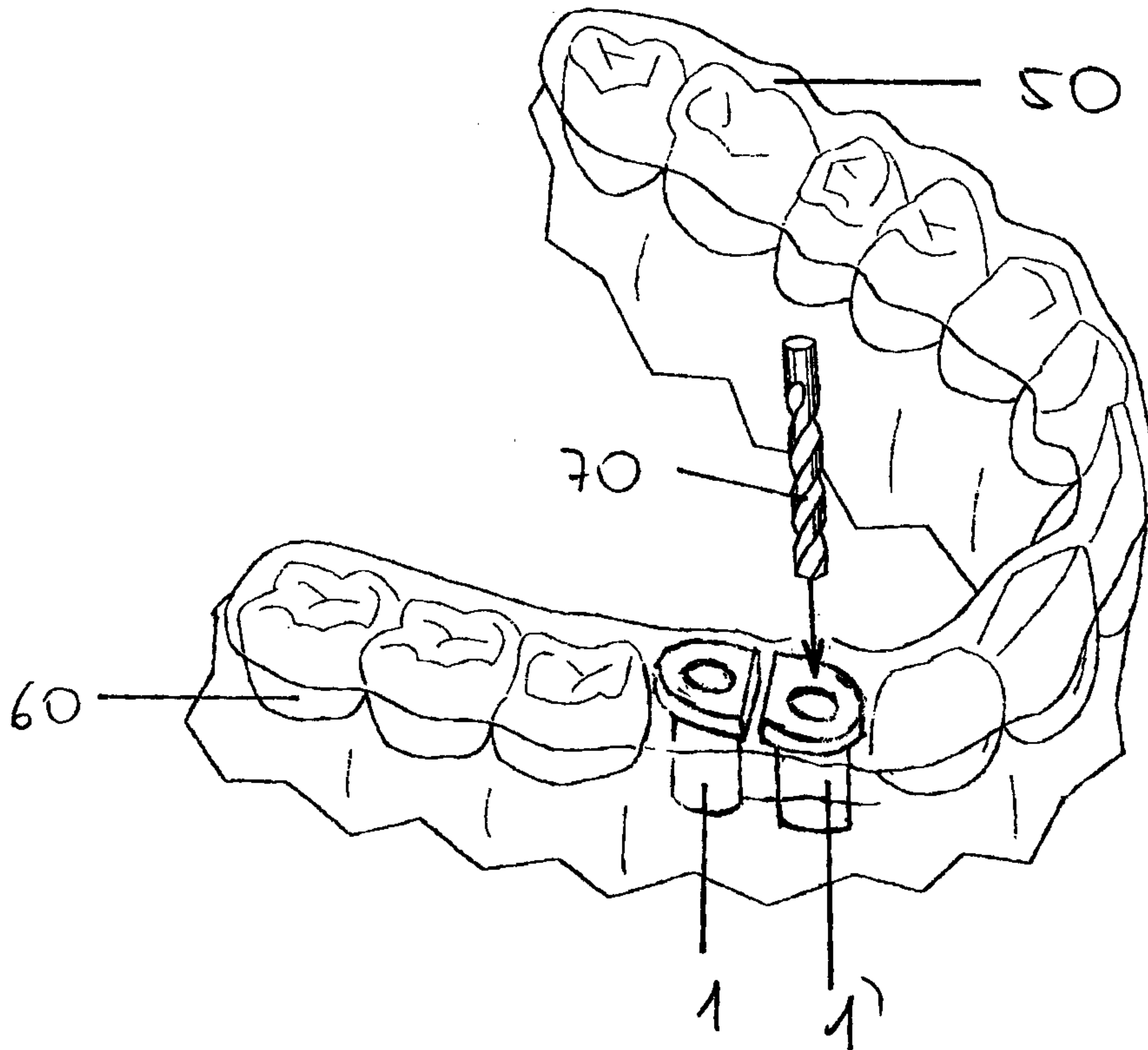

Fig. 4

