

**(12) STANDARD PATENT APPLICATION (11) Application No. AU 2005201907 A1**  
**(19) AUSTRALIAN PATENT OFFICE**

(54) Title  
**Cassette assembly**

(51) International Patent Classification(s)  
**A61L 2/26 (2006.01)**

(21) Application No: **2005201907** (22) Date of Filing: **2005.05.05**

(30) Priority Data

(31) Number	(32) Date	(33) Country
<b>10/856,435</b>	<b>2004.05.28</b>	<b>US</b>
<b>10/978,034</b>	<b>2004.10.29</b>	<b>US</b>

(43) Publication Date: **2005.12.15**

(43) Publication Journal Date: **2005.12.15**

(71) Applicant(s)  
**Ethicon, Inc.**

(72) Inventor(s)  
**Kohler, James P.**

(74) Agent / Attorney  
**Callinan Lawrie, 711 High Street, Kew, VIC, 3101**

2005201907 05 May 2005

### ABSTRACT

A cassette for a sterilizer has one or more cells containing a sterilant, is received within a sleeve and the sleeve carries a bar code which is encoded with a lumen claim. The lumen claim relates to a sterilization cycle for which the cassette is designed.

**AUSTRALIA**

**Patents Act 1990**

**COMPLETE SPECIFICATION**

**FOR A STANDARD PATENT**

**ORIGINAL**

---

**TO BE COMPLETED BY APPLICANT**

**Name of Applicant:** ETHICON, INC.

**Actual Inventor:** James P. KOHLER

**Address for Service:** CALLINAN LAWRIE, 711 High Street,  
Kew, Victoria 3101, Australia

**Invention Title:** CASSETTE ASSEMBLY

The following statement is a full description of this invention, including the best method of performing it known to us:-

---

CASSETTE ASSEMBLY

This application is a continuation-in-part of U.S. Patent Application Serial No. 10/856,435 filed May 28, 2004, the contents of which are incorporated herein by reference.

5

Background of the Invention

This application relates to cassettes for delivering sterilant to an instrument sterilizer, and more particularly to such cassettes and their packaging.

10

One popular method for sterilizing instruments, such as medical devices, is to contact the devices with a vapor phase chemical sterilant, such as hydrogen peroxide. In many such sterilizers, it is preferred to deliver the sterilant in liquid form and vaporize it in the sterilizer. One particularly convenient and accurate method for delivering the liquid sterilant is to put a predetermined quantity of sterilant into a cassette and deliver the cassette to the sterilizer. The sterilizer then automatically extracts the sterilant from the cassette and uses it for sterilization procedure. Typically, such a cassette would entail multiple cells containing equal amounts of liquid sterilant with a sterilization procedure employing the sterilant from one or more cells. Such a system is currently available in the STERRAD® sterilization system available from Advanced Sterilization Products in Irvine, California.

15

20

U.S. Patent Nos. 4,817,800; 4,869,286; 4,899,519; 4,909,287; 4,913,196; 4,938,262; 4,941,518; 5,882,611; 5,887,716; and 6,412,340, each incorporated herein by reference, disclose such cassettes and a method for draining liquid sterilant from a cell within a cassette.

25

It has been known to employ a bar code on such a cassette or a sleeve into which is received the cassette. Typically, a particular model of sterilizer employs a particular cassette design. The bar code on the cassette may include such information as the model number of the sterilizer for which it is designed and the expiration date of the cassette. Thus, if the wrong or an expired cassette is inserted, the sterilizer can determine this by reading the code and then reject the cassette.

30

2005201907 05 May 2005

Summary of the Invention

A cassette for a sterilizer according to the present invention comprises a body having one or more cells containing a quantity of liquid sterilant. The body is received  
5 within a sleeve and a bar code on the sleeve is encoded with a lumen claim.

Preferably, the bar code has encoded therein an identifier for a type or model of sterilizer to which the lumen claim is related.

10 In one aspect of the invention, the sterilant comprises hydrogen peroxide solution.

The lumen claim, in one aspect of the invention, specifies a length and internal diameter of a lumen. Additionally, it can specify a material from which the lumen is constructed. The encoding can be an identifier representative of the length and internal  
15 diameter, or the actual length and internal diameter can be encoded.

The bar code in one aspect of the invention resides on a label attached to the sleeve. Alternatively, it is printed onto the sleeve.

20 In a preferred embodiment, the cassette has a plurality of the cells.

Brief Description of the Drawings

FIG. 1 is a block diagram of a sterilizer employing a cassette according to the  
25 present invention;

FIG. 2 is a rear perspective view of a cassette handling system according to the present invention;

30 FIG. 3 is a front perspective view of the cassette handling system of FIG. 2;

FIG. 4 is a front perspective view of the cassette handling system of FIG. 2 showing a spent cassette collection box;

FIG. 5 is a rear perspective view of the cassette handling system of FIG. 2 showing its carriage in the insert position;

5 FIG. 6 is a rear perspective view of the cassette handling system of FIG. 2 showing its carriage as it moves toward the home position;

FIG. 7 is a rear perspective view of the cassette handling system of FIG. 2 showing its carriage in position to read a bar code on the cassette;

10 FIG. 8 is a rear perspective view of the cassette handling system of FIG. 2 showing its carriage in the home position;

FIG. 9 is a front perspective view of the cassette handling system of FIG. 2 showing its carriage in position to tap the cassette's first cell;

15

FIG. 10 is a cross sectional view of the cassette showing a cell therein;

FIG. 11 is a front perspective view of the cassette handling system of FIG. 2 showing upper and lower needles on an extractor subsystem penetrating the first cell of the cassette;

20

FIG. 12 is a front perspective view of the cassette handling system of FIG. 2 showing upper and lower needles on the extractor subsystem in position to penetrate the last cell of the cassette;

25

FIG. 13 is a front perspective view of the cassette handling system of FIG. 2 showing the cassette being ejected therefrom;

FIG. 14 is a flow chart of the cassette handling process;

30

FIG. 15 is a rear perspective view of an alternative embodiment of a cassette handling system of the present invention employing RFID technology;

FIG. 16 is a memory map of an RFID tag of the cassette shown in FIG. 15;

2005201907 05 May 2005

FIG. 17 is a top plan view of an unfolded blank for forming the spent cassette collection box of FIG. 4;

5 FIG. 18 is a perspective view of the blank of FIG. 17 folded to form the spent cassette collection box;

FIG. 19 is a perspective view of a cassette according to the present invention having an outer sleeve;

10

FIG. 20 is a side elevational view of a cassette handling system for processing the cassette and sleeve of FIG. 19;

FIG. 21 is a top plan view of a cassette according to the present invention received within a packaging system according to the present invention; and

15

FIG. 22 is a top plan view of the cassette and packaging system of FIG. 21 prior to final closure of the package.

20 Detailed Description

Sterilizer Overall Configuration

FIG. 1 shows in block diagram form a vapor phase sterilizer 10 employing a cassette handling system 12 according to the present invention. The sterilizer 10 comprises a vacuum chamber 14 and a vacuum pump 16 for exhausting atmosphere therefrom. A vaporizer 18 receives liquid sterilant from the cassette handling system 12 and supplies it in vapor form to the vacuum chamber 14. A screen grid electrode 20 is provided within the vacuum chamber 14 for exciting the contents into the plasma phase during a portion of the sterilization cycle. A micro filtered vent 22 and valve 24 allow sterile air to enter the vacuum chamber 14 and break the vacuum therein. A control system 28 ties in to all of the major components, sensors and the like within the sterilizer 10 to control the sterilization cycle.

30

A typical sterilization cycle might include drawing a vacuum upon the vacuum chamber 14 and turning on power to the electrode 20 to evaporate and extract water from

2005201907 05 May 2005

the vacuum chamber 14. The electrode 20 is then powered off and a low vacuum of less than 1 torr drawn on the vacuum chamber 14. Sterilant, such as hydrogen peroxide solution, is vaporized by the vaporizer 18 and introduced into the vacuum chamber 14 where it diffuses into contact with the items to be sterilized and kills microorganisms thereon. Near the end of the cycle, power is again applied to the electrode 20 and the sterilant is driven into the plasma phase. The electrodes 20 are powered down and filtered air is drawn in through the valve 24. This process can be repeated. The Jacobs et al. U.S. Patent Application, Publication No. 20030235511, incorporated herein by reference, illustrates in detail such a cycle.

10  
Cassette Handling System

Turning also to FIGS. 2 to 4, the cassette handling system 12 according to the present invention is shown. It comprises in gross, a carriage 32 for holding a cassette 34, a lead screw 36 and motor 38, an extractor subsystem 40 and a scanner 42.

15  
The carriage 32 comprises a bottom panel 44, a side panel 46 and top panel 48 along with small vertical flanges 50 and 52 on the top and bottom and top panels 48 and 44, respectively, to capture the cassette 34. The bottom, side and top panels 44, 46 and 48 flare outwardly at an entrance 54 of the carriage to aid in insertion of the cassette 34. Two spring catches 56 on the flanges 50 and 52 engage irregular surfaces of the cassette 34 to firmly position the cassette 34 within the carriage 32.

20  
The carriage 32 travels along the lead screw 36 and is supported on an upper rail 58. A lead screw nut 60 attached to the bottom panel 44 and having a threaded opening 62 and an unthreaded opening 63 receives the lead screw 36 and effects horizontal movement of the carriage 32 in response to rotations of the lead screw 36. Flanges 64 extend outwardly from the top panel 48 and flanges 66 extend outwardly from the side panel 46 each having openings 69 for receiving the upper rail 58. The motor 38 is preferable a stepping motor and connects to the lead screw 36 to precisely control the horizontal position of the cassette 34 relative to a frame 68.

30  
The extraction assembly 40 comprises an upper needle 70 and a lower needle 72, each being of a lumened configuration. The upper needle connects to an air pump 74

which can force air out through the upper needle 70. The lower needle 72 connects to a valve 76 and from there is plumbed to the vaporizer 18.

5 The scanner 42 is oriented so as to be able to read a barcode 80 on the cassette 34 as well as a barcode 82 on a spent cassette collection box 84. Upon insertion of the cassette 34 into the carriage 32 the scanner 42 reads the cassette barcode 80. The barcode 80 is preferably encoded with information regarding the contents of the cassette 34, including lot numbers and expiration dates. This information can be used to determine whether the cassette 34 is fresh and of the correct type and whether the cassette 34 has  
10 been used in the system before and thus is at least partially empty. The code is communicated to the control system 28 which makes these determinations.

The scanner 42 can also see the spent cassette collection box barcode 82 when the carriage 32 moves inwardly and away from the scanner 42. Each spent cassette collection  
15 box 84 preferably has two barcodes 82, one in each opposing corner so that the scanner 42 can see one of them regardless of which end of the spent cassette collection box 84 is inserted first. With the spent cassette collection box 84 filled, the spent cassettes 34 block the barcode 82 which alerts the control system 28 that there is no capacity for receiving additional spent cassettes 34. Preferably this message will be output to a user, such as on a  
20 display screen (not shown). If the cassette 34 is empty it will not be ejected and no new cycles will be run until a spent cassette collection box 84 having capacity to receive a spent cassette 34 is placed into the sterilizer 10.

A forward flag 86 and rearward flag 88 project outwardly and downwardly from  
25 the carriage side panel 46. They slide through a slot 90 in a slot sensor 92 which detects their presence within the slot 90, such as by blocking a beam of light. Travel of the front flag 86 and rear flag 88 through the slot sensor 92 provides a reference location of the carriage 32 to the control system 28.

30 The top panel 48 of the carriage 32 can rotate about the upper rail 58. A spring 94 between the top panel 48 and side panel 46 biases the top panel 48 downwardly to hold the cassette 34 within the carriage 32. A disposing cam 96 sits behind the side panel 46 and aligns with an ejecting tab 98 which extends outwardly and downwardly from the top panel 48 and which can project through an opening 100 in the side panel 46 when the top panel

2005201907 05 May 2005

2005201907 05 May 2005

48 rotates upwardly. Such rotation of the top panel 48 releases its hold upon the cassette 34 and due to the ejecting tab 98 projecting through the opening 100 pushes the cassette 34 out of the carriage 32 and into the spent cassette collection box.

5           The disposing cam 96 controls rotation of the top panel 48. It comprises a generally triangular shape, having an outwardly facing side 102, forwardly facing side 104 and rearwardly facing side 106. Turning also now to FIG. 5, it mounts for rotation upon an upwardly extending spindle 108. A spring 110 biases the disposing cam 96 counterclockwise, urging the outwardly facing side 102 into contact with an abutment 112.  
10 Inward movements of the carriage 32 allow the ejecting tab 98 to cam over the rearwardly facing side 106 of the disposing cam 96, thus allowing the disposing cam 96 to rotate clockwise and allow the ejecting tab 98 to pass thereby without effecting rotation of the top panel 48. However, outward movement of the carriage 32 causes the ejecting tab 98 to cam over the forwardly facing side 104 of the disposing cam 96. During such motion  
15 contact between the outwardly facing side 102 of the disposing cam 96 and the abutment 112 prevents rotation of the disposing cam 96. The camming of the ejecting tab 98 thus causes it to move laterally toward the side panel 46 thereby rotating the top panel 48 upwardly and releasing the cassette 34 from the carriage 32.

20           Prior to inserting the cassette 34 the carriage 32 is fully retracted to its outward position (to the left as shown in FIG. 5). In this position also, a forward end 114 on the lead screw nut 60 engages a stop 116 thus positively locating the position of the carriage 32. Turning also now to FIG. 6, manual insertion of the cassette 34 causes the carriage 32 to move inwardly (to the right as shown in FIG. 6) and moves the front flag 86 into the slot  
25 sensor 92. This movement is preferably caused by the physical force from inserting the cassette 34, however, a torque or other sensor could be applied to allow the stepping motor 38 to take over this movement upon feeling the force of the cassette 34 being inserted into the carriage 32. Allowing this movement to come from the force of the insertion of the cassette 34 ensures that the cassette 34 is fully seated within the carriage 32 before the  
30 movement begins.

Once the front flag 86 is read by the slot sensor 92 the stepper motor 38 takes over and starts to move the carriage 32 inwardly. Turning also now to FIG. 7, during this stage, the scanner 42 scans the barcode 80 on the cassette 34. The control system 28 interprets

the information coming from the barcode 80 and determines whether the cassette 34 has been used in the sterilizer 10 before, whether the cassette contains fresh sterilant, and other data as appropriate. Preferably, the information on the barcode 80 is encrypted to prevent unauthorized parties from creating cassettes which may not meet the quality standards  
5 necessary for proper sterilization.

If the control system 28 rejects the cassette 34 a carriage 32 is moved sufficiently inwardly so as to pass the ejecting tab 98 past the disposing cam 96 and is then moved back to the insertion position shown in FIG. 5 to eject the rejected cassette 34. If the  
10 cassette 34 is accepted, the carriage 32 continues inward movement to the home position as shown in FIG. 8 in which the rear flag 88 has just passed out of the slot sensor 92.

Turning also now to FIGS. 9 and 10, the cassette 34 comprises a plurality of cells 118 containing liquid sterilant 120. Various structures of a cassette may be employed.  
15 The cassette 34 shown comprises a hard outer shell 122, preferably formed of an injection molded polymer, such as high impact polystyrene, high density polyethylene or high density polypropylene, which encloses the individual cells 118, the cells 118 being formed of a blow molded polymer such as low density polyethylene. However, a more rigid material can be used to form the cassette cells 118 in which case the outer shell 122 could  
20 be omitted. In the cassette 34 shown, an upper aperture 124 and lower aperture 126 through the shell 122 allows the upper and lower needles 70 and 72 to penetrate the shell. The cell 118 is formed of a material easily penetrated by the needles. If the cell 118 is formed of a more substantial material, a thinning of the material could be provided at the locations to be penetrated by the needles 70 and 72.

25 The control system 28 uses the home position of FIG. 8 as a reference position for positioning the various cells 118 in front of the extractor subsystem 40. By moving the carriage 32 a predetermined amount from the home position a given cell 118 can be brought to face the extractor system 40. In FIG. 9, cell one has been placed in front of the  
30 extractor system 40. Turning also now to FIG. 11, an actuator 128 drives the extractor subsystem 40 toward the cassette 34 causing the upper and lower needles 70 and 72 to penetrate the upper and lower apertures 124 and 126 and enter the cell 118. After the needles have fully extended, the air pump 74 drives air into the cell 118 through the upper needle 70. The system waits a couple of seconds before starting the air pump 74 and

2005201907 05 May 2005

opening the valve 76 to ensure proper placement and settling of the needles within the cell 118. The sterilant 120 flows out through the lower needle 72 and is piped off to the vaporizer 18. After a sufficient time to extract the sterilant 120, the air pump 74 switches off and the actuator retracts the extractor subsystem 40 from the cassette 34.

5

The vaporizer 18 connects to the vacuum chamber 14 which allows the lower needle 72 to easily be placed at a pressure below atmospheric. Thus, the pump 74 can optionally be replaced by a valve (not shown) open to atmosphere, in which case the incoming atmospheric pressure air will provide the driving force to empty the cell 118.

10

Rather than employ upper and lower needles 70 and 72, one needle having two lumens therethrough would suffice. One of the lumens would provide pressurizing gas and one would extract liquid sterilant. A further alternative arrangement would be to pierce the cell 118 vertically, or substantially so, from an upper part of the cell 118, preferably with such a double lumen needle. This would minimize leakage around the hole created by the needle entering the cell 118. Such entry would also allow the tip of the needle to come closer to the lowest point of the cell 118 for maximum extraction efficiency. If one desired to extract less than all of the contents of the cell 118, one method would be to position the needle extracting the sterilant, such as the lower needle 72 or the just mentioned double lumen needle, at the level in the cell 118 down to which extraction is desired. Liquid sterilant above the position would be extracted and sterilant below would remain. This would be particularly convenient with the just mentioned vertically traveling needle.

15

20

Turning also to FIG. 12, each time the control system 28 determines that a new dose of sterilant 120 is required, the stepper motor 38 moves the cassette to position the next cell 118 in front of the extractor subsystem 40 and a new extraction takes place. Multiple extractions may be employed for a given sterilization cycle. When the cassette 34 has been depleted, the carriage 32 moves towards the insert position thus causing the ejecting tab 98 to cam over the disposing cam 96 to rotate the top panel 48 upwardly and project the ejecting tab 98 through the opening 100 to drive the cassette 34 out of the carriage 32 as described above and as shown in FIG. 13. The cassette 34 falls into the spent cassette collection box 84 and the carriage 32 returns to the insertion position as shown in FIG. 5.

25

30

The foregoing discussion described the operation of the cassette handling system in some detail. FIG. 14 shows, in block diagram form, the basic operation of the cassette handling system 12.

5            Lumen Claim

Typically, sterilizers and their cycle parameters have been optimized to enable sterilization of the most challenging loads possible so as to not unduly restrict which devices might be sterilized therein. Long narrow lumens being one of the most challenging areas to sterilize have become the de facto standard in defining the potency of a sterilization process, i.e. its ability to sterilize devices having a lumen of a certain diameter and length. The longer and narrower the lumen which can be sterilized, the more efficacious the sterilizer cycle. A sterilizer is thus said to achieve a lumen claim of lumen diameter by lumen length, as for instance 1 mm x 100 mm. The lumen claim can also include the material forming the lumen. Typically, the lumen claim will be the claim which has been approved by a regulatory agency such as the US Food and Drug Administration, but can represent merely the lumen which the sterilizer and cycle can effectively sterilize. Typically, sterilization entails a six log reduction in the challenge microorganisms. In hydrogen peroxide based sterilization systems the preferred challenge microorganism is *Geobacillus stearothermophilus*.

20            Rather than always run the sterilizer to achieve its maximum lumen claim, it may be desirable to run the sterilizer 10 in different cycles depending upon the devices loaded therein for sterilization. Preferably, an operator selects a lumen claim when loading the sterilizer 10 based upon the most challenging lumen device being loaded and then enters that lumen claim into the control system 28. Alternatively, the devices can be coded themselves, such as with a bar code which is scanned as the device is loaded, and the control system 28 selects the appropriate cycle to meet a particular lumen claim based upon the most challenging lumen device which was scanned. A set of lumen claim cycles programmed into the sterilizer might include the following: a) 1 mm x 1,000 mm, b) 1 mm x 500 mm, c) 2 mm x 100 mm, and d) no lumen. The cycles for the less demanding lumen claims can be adjusted, such as injecting less sterilant, employing a lower concentration sterilant, a shorter contact time, or a less demanding vacuum (higher pressure). In general, employing a lower concentration sterilant can provide benefits in gentler processing of the instruments to be sterilized.

2005201907    05 May 2005

To provide flexibility in optimizing differing lumen sterilization cycles, preferably cassettes 34 having loads of sterilant optimized for a given lumen claim cycle are provided. Preferably, the lumen claim is encoded onto the barcode 80 along with other data such as the sterilizer model for which the cassette 34 is intended and the expiration date.

5 A suggested data layout for the barcode 80 comprises the following fields: a) sterilizer model for which the cassette 34 is intended (three binary digits - associated with a look-up table); b) expiration date (eight binary digits representing the number of months from a fixed date); c) lumen claim (three binary digits - associated with a look-up table).  
10 Alternatively, the lumen claim could be represented by separate lumen internal diameter and length fields, preferably in millimeters and decimeters respectively. Further, as illustrated in the last row of Table 1a some lumens having different dimensions may nonetheless have equivalent processing requirements. Preferably, one of the equivalent lumens would be coded onto the barcode 80, with the sterilizer's control system being programmed with the equivalents. Many coding schemes are possible within the scope of  
15 the invention.

Tables 1a and 1b illustrate how certain parameters of the cycle can be modified to treat particular lumens.

**Table 1a - 173L chamber with two loads**

Device	Peroxide concentration	Peroxide amount	Time required to kill about $1 \times 10^6$ <i>Geobacillus stearothermophilus</i> spores
Stainless steel Surface	59% wt	1 g	5 minutes
1mmx1000mm TEFLON* lumen	50% wt	2 g	15 minutes
1mmx125mm, 2mmx250mm or 3mmx400mm Stainless Steel lumen	59% wt	1.7 g	20 minutes

\*polytetrafluoroethylene, TEFLON is a trademark of 3M Co.

2005201907 05 May 2005

Table 1b - 51L chamber with one load

Device	Peroxide concentration	Peroxide amount	Time required to kill about $1 \times 10^6$ <i>Geobacillus stearothermophilus</i> spores
2mmx400mm Stainless Steel lumen	90% wt	0.23 g	3 minutes
1mmx150mm Stainless Steel lumen	90% wt	0.34 g	3 minutes
1mmx500mm Stainless Steel lumen	90% wt	0.45 g	7 minutes
1mmx350mm TEFLON* lumen	90% wt	0.45 g	3 minutes

\*polytetrafluoroethylene, TEFLON is a trademark of 3M Co.

Beyond merely entering lumen data, the control system 28 can be configured to take multiple inputs and use this information to determine how a subsequent sterilization cycle should be performed. Such inputs can include: whether the load is wrapped or unwrapped (such as in Central Supply Room "CSR" wrap), the weight of the load, the number of items (and more preferably the number of certain types of items such as rigid or flexible endoscopes, the materials of the load, such as the proportion of plastics, the presence or proportion of polymers highly absorbtive of hydrogen peroxide such as, but not limited to, polyamides, polyurethanes, silicone rubbers, PVCs, Polymethyl methacrylates and polysulfones, and whether full sterilization or merely high level disinfection is needed. Some of these inputs can be determined by the machine with addition of appropriate sensors, such as for example the weight of the load which can be determined via some form of scale preferably incorporated into the sterilizer 10 or via measuring plasma power.

The sterilizer 10 has many sensors including those to measure temperature, pressure, sterilant concentration and plasma power. These in conjunction with the user

inputs are used by the control system to adjust the parameter of the sterilization cycle in order to adequately treat the load in the most efficient manner. Table 2 illustrates how a cycle can be modified to for several user inputs.

**Table 2 - Cycle Response to User Input**

<b>Attributes of load</b>	<b>Response</b>	<b>Control mechanism</b>
<b>Sterilization or high level disinfection</b>	<b>High level disinfection-</b> low sterilant concentration or/and mass/shorter exposure time <b>Sterilization-</b> high sterilant concentration or/and mass	Determine sterilant/disinfectant concentration level and quantity to reach sterilant level required. Monitor concentration/amount by sterilant sensor and maintain at the required level
<b>Wrapped or unwrapped load</b>	Unwrapped- low concentration/mass delivery Wrapped- higher concentration/mass delivery	Determine sterilant/disinfectant concentration level and quantity to reach sterilant level required. Monitor concentration/amount by sterilant sensor and maintain at the required level
<b>Load volume and weight</b>	High volume: possibly more absorption High weight: possibly higher condensation	Monitor and maintain the required sterilant/disinfectant concentration level. Set temperature at higher level to reduce absorption and condensation effects. Pre-heat the load if necessary. High venting/residual removal treatment.
<b>Loads contains materials that are a decomposer or absorber to the sterilant/disinfectant</b>	Higher injection mass/concentration and temperature may be required	Monitor and maintain the required sterilant/disinfectant level. High venting/residual removal treatment if excessive absorb is present (Identify from sterilant concentration sensor output)

<b>Load contains lumens: short vs. long</b>	High concentration and/or mass, longer exposure time and pre-processing pressure gradient	Set concentration and pressure gradient levels accordingly
---	---	--

In one aspect of the invention, the user would first choose between running one or more standard cycles, or one or more user programmed cycles, or enter load and process data to design a cycle. Under the option of entering load data the user could first select whether sterilization or high level disinfection is required. If sterilization is selected, the user would preferably enter whether the load contained wrapped containers or items. The user would second enter whether the load contained lumens or not. For a load lacking lumens the overall weight and materials in the load would be entered. These entries could be made item by item, or as an aggregate. For lumens, additional data such as the lumen length and internal diameter would be entered. Again, this data could be entered as the most challenging single lumen, or item by item. Thirdly, the user would enter load preparation information such as whether preheating or moisture removal steps should be taken with the load. Alternatively, the control system could recommend or determine whether these steps should be taken based upon the data entered. These steps can lengthen the overall process time and in some instances the user may wish to opt out of their use to speed the cycle. Fourth, the user would enter data as to the source of sterilant (bulk or cassette), sterilant concentration, sterilant volume and type of sterilant. Again, some of this could rather be recommended or determined by the control system based upon the entered data, which could also provide the user with a message as to which type of cassette should be loaded for instance. Finally, information about residual removal would be entered, i.e. whether a residual removal step should be taken at the end of the cycle and whether heat, plasma, sterile air purging, vacuum or some combination thereof should be employed. Again, this information could rather be recommended or determined by the control system based upon the data entered. The user would have the option of saving this cycle set-up so that it could be chosen from a cycle menu for later cycles of similar devices. Names could be provided to the cycle set-up, such as by procedure instrument set, to allow easy retrieval of the appropriate cycle in the future.

Determinations of cycle changes can be made based upon table look-ups employing cycle corrections based upon known cycle modifications related to load modifications,

05 May 2005

2005201907

preferably backed up by test data. For instance, tests run on lumens of varying diameter and ID can determine exposure times and sterilant concentrations that produce reliable sterilization. In addition, calculations of integrated sterilant exposure (quantity and time) can be employed. For instance, experiments have shown that a particular lumen can be  
5 successfully sterilized by a particular integrated sterilant exposure; varying the quantity or time while maintaining the overall integrated exposure still achieves a reliable sterilization.

The system of reading barcodes on the cassette 34 and spent cassette box 84 can be replaced with radio frequency identification tags, commonly known as RFID tags. An  
10 RFID system 130 is shown in FIG. 15. It comprises a controller 132 connected via an SPDT reed relay 134 to a cassette insertion antenna 136 located on the carriage 32 and a cassette disposal antenna 138 located beneath the spent cassette box 84. Each cassette 34 carries a cassette RFID tag 140. Similarly, each spent cassette collection box 84 carries a collection box RFID tag 142. Preferably, the controller 132 comprises a Texas Instruments  
15 multifunction reader module S4100 and the RFID tags 140 and 42 comprise Texas Instruments RFID tag RI-101-112A each of which are available from Texas Instruments, Dallas, Texas.

The control system 28 (FIG. 1) selects one of the antennas, as for instance the  
20 cassette insertion antenna 136 and sends a signal to the relay 134 to engage this antenna with the RFID controller 132. The antenna reads the information stored on the cassette insertion RFID tag 140 which identifies the cassette 34 and its contents. The information read is similar to the information read using the barcode, however preferably, the RFID tag 140 has the ability to update the information stored thereon. Accordingly, additional data  
25 such as the filling status of individual cells 118 within the cassette 34 can be stored on the RFID tag. Thus, if the cassette 34 is removed and then reinserted into the sterilizer 10, or even into different sterilizer 10, the control system 28 can be apprised of the status of each of the individual cells 118 within the cassette 34. This allows the reuse of a partially used cassette 34. Also, since the RFID tag 140 can hold more data than the barcode 80, more  
30 data about the cassette 34, its contents and manufacturing can be included thereon.

The spent collection box antenna 138 reads the spent collection box RFID tag 142 to determine the presence or absence of the spent cassette collection box 84. Other data such as a unique identifier for the box 84, the capacity of the box 84, how many cassettes

2005201907 05 May 2005

34 are currently in the box 84 and how many of the cells 118 therein are not empty can be included on the RFID tag 142. The control system 28 can track how many cassettes 34 have been ejected into the box to determine whether it has room for more spent cassettes 34. The antenna 138 can also read the cassette RFID tags 140 and count the number of cassettes 34 within the box 84. When the box 84 is full the control system 28 alerts the operator, as by a message on a screen. This message can also include information regarding the cassettes 34 within the box 84. For instance if not all of the cassettes 34 have been completely drained the operator can be informed of this to decide if more careful disposal may be indicated.

10

RFID technology is disclosed in the following U.S. Patents, each of which is incorporated herein by reference: U.S. Patent Nos. 6,600,420; 6,600,418; 5,378,880; 5,565,846; 5,347,280; 5,541,604; 4,442,507; 4,796,074; 5,095,362; 5,296,722; 5,407,851; 5,528,222; 5,550,547; 5,521,601; 5,682,143 and 5,625,341.

15

RFID tags typically comprise an antenna and an integrated circuit produced in a thin form factor so they can be inconspicuously placed upon an object such as the cassette 34. Radio frequency energy sent by the antennas 136 and 138 induce sufficient current within the antenna inside the RFID tags 140 and 142 to power the integrated circuit therein. Some types of RFID tags carry their own power source and have longer detection ranges, but that adds additional expense and is probably not justified for the present use.

20

FIG. 16 shows the memory map for the memory within the RFID tags 140 and 142. A 64-bit unique ID (UID) is set at the factory and cannot be changed. Each RFID tag has its own unique number here. Sixty-four 32-bit blocks can be programmed by the user. These can be populated with information such as the manufacture date, expiration date, product ID, serial number, lot numbers, manufacturing location, filling status of the cells, strength and type of sterilant, time spent within the sterilizer 10 and the like.

25

Some sterilants are affected by heat. The RFID tag 140 can optionally include temperature collection instrumentation and update that information on the tag. If design temperature profiles are exceeded, such as a maximum temperature or excessive temperature over a time period, then the cassette 34 can be rejected by the control system 28. Temperature measuring RFID tags are available from KSW-Microtec, Dresden,

30

05 May 2005

2005201907

Germany and from Identec Solutions, Inc., Kelowna, British Columbia, Canada. The interior of the sterilizer 10 where the cassette 34 sits may be higher than ambient temperature. Thus, it may be beneficial to put a maximum residence time (on board shelf life) on the tag 140 or even to update on the tag 140 this time the cassette has already spent  
5 inside of the sterilizer.

To test sterilant measuring equipment in the sterilizer 10, it may be beneficial to provide cassettes 34 having water or other fluids within one or more cells 118. Information regarding the special nature of the cassette 34 and its contents could be written  
10 onto the RFID tag.

During a cycle the sterilizer may only require part of the contents of a cell 118. For instance, a particular cycle may call for the contents of one and a half cells. The half filled nature of the cell 118 can be stored and then for the next cycle that cell 118 can be drained.  
15

Preferably, communications between the tag 140 and 142 and the controller 132 are encrypted. For instance, the UID can be XORed with an eight-bit master key to form a diversified key for encrypting the data. Encryption algorithms such as the data encryption standard (DES) triple DES, asymmetrical encryption standard (AES) or RSA security can  
20 be used for the encryption. The RFID controller 132 reads the data and the algorithm in the control system 28 decrypts the data to reveal the stored information.

Other methods could be used to communicate between the cassette 34 and the sterilizer 10. For instance information could be stored magnetically on the cassette 34,  
25 such as with a magnetic encoded strip, and be read by a magnetic reader on the sterilizer. Wireless technology is becoming cheaper every day and it is envisioned that the cassette 34 could include an active transmitter and a power source (i.e. a battery) such as powered RFID tags or Bluetooth, 802.11b or other communication standard.

Further, the sterilizer 10 can be set up to communicate back to a central source,  
30 such as the manufacturer or distributor thereof, and provide information regarding its performance and the performance of the cassettes 34. Poorly performing cassettes 34 could be identified, as for instance sterilant monitors in the sterilizer not detecting sterilant during a cycle thus indicating some failure such as an empty cassette or bad sterilant

2005201907 05 May 2005

therein. An improperly manufactured batch of cassettes 34 could then be quickly identified and recalled. Such communication could occur over telephone, pager or wireless telephone networks or over the Internet.

5 Turning now also to FIGS. 17 and 18, the spent cassette collection box 84 is preferably folded from a single sheet of printed cardboard or other stock. FIG. 17 shows an unfolded blank 150 and FIG. 18 shows the blank 150 folded to form the spent cassette collection box 84.

10 The blank 150 is divided by a series of fold lines (shown dashed) and cut lines into a bottom panel 152, side panels 154, end panels 156 and top flaps 158. Folding tabs 160 extend laterally from the side panels 154. Additional folding tabs 162 extend laterally from the end panels 156. Barcodes 82 are printed on the side panels 154 in a position to be visible in an upper interior corner of the spent cassette collection box 84 when it is folded  
15 into the configuration shown in FIG. 18. A pair of top flap locking tabs 164 extend from the top flaps 158 and fit into slots 166 in the opposing top flap 158 when the box 84 is closed and into slots 168 at the intersection of the bottom panel 152 and side panel 154 when the box 84 is opened.

20 To fold the box, the folding tabs 160 on the side panels 154 are folded upwardly and then the side panels 154 are folded upwardly, thereby aligning the folding tabs 160 with the intersection between the bottom panel 152 and the end panels 156. The end panels 156 are then folded upwardly and the end panel folding tabs 162 are folded downwardly over the folding tabs 160. Locking tabs 170 on the end panel folding tabs 162  
25 fit into slots 172 at the intersection between the bottom panel 152 and end panels 156.

To place the box 84 into the open position as shown in FIG. 18, the top flaps 158 are folded downwardly to the outside and the locking tabs 164 fitted into the slots 168. Once the box 84 is filled with spent cassettes, the top flaps 158 are folded upwardly over  
30 the top and the locking tabs 164 can then be fitted into the slots 166 on the opposing top flaps 158. This unique folding arrangement allows spent cassettes 34 to fall into the open box 84 easily without the top flaps 158 getting in the way and also allows easy closure of the box 84 once it has become filled.

05 May 2005

2005201907

Fig. 19 shows a cassette 200, similar to the cassette 34. However, the cassette 200 fits within an outer sleeve 20 which protects the cassette 200 and which is preferably absorptive of the liquid sterilant such that any droplets thereof which might remain on the cassette 200 after a sterilization cycle would be absorbed by the sleeve 202 thereby preventing user contact with the sterilant. FIG. 20 shows the cassette 200 within an alternate cassette handling system 204.

In this system 204 the cassette 200 and sleeve 202 enter through an opening 205. Rollers 207 move the cassette 200 and sleeve 202 into the system 204 where a bar code 206 on a flap 208 is read by a bar code reader 210 through a window 211 through the sleeve 202 and the information passed to a control system 212. The control system 212 checks that a proper cassette 200 has been inserted into the system 204 and then signals the rollers 207 to extract the cassette 200 from the sleeve 202. Preferably, the bar code 206 is encoded with a lumen claim as previously discussed.

When the cassette 200 returns to the sleeve 202 the flap 208 is pushed out of the way so that it will not be read if the cassette 200 and sleeve 202 are reinserted into the system 204, thereby preventing use of a spent cassette 200. Of course, rather than employ the flap 208 the bar code can be printed on the sleeve 202 without a flap, or on the cassette 200 and be visible through the window 211. In this case the previously discussed methods for ensuring that the cassette has not been used are preferably employed.

#### PACKAGING FOR THE CASSETTE

FIG. 21 illustrates a packaging system 300 for a cassette 302 similar to the cassette 34. The cassette 302 is received within a clear, liquid impermeable outer wrap 304. A label 306 and bar code 308 are visible through the wrap 304. An RFID or other tag could substitute for or compliment the bar code 308. The wrap 304 is preferably formed of clear oriented polypropylene. An absorbent web 310 attached to the inside of the wrap 304 encircles the cassette 302 about the portion which contains the hydrogen peroxide. The absorbent web 310 is preferably formed of a non-woven matrix of melt blown polypropylene impregnated with a superabsorbent polymer. For the purposes of the present invention, the term "superabsorbent polymer" refers to materials which are capable of absorbing and retaining at least about 30 times their weight in the liquid sterilant of the cassette 302 under a 0.5 psig pressure. Suitable super absorbent polymers include

polyacrylamides and polyacrylates, and in particular crosslinked sodium polyacrylate. One suitable superabsorbent web is Korma HY0301038 available from BPA Fiberweb of Nashville, TN.

5           The packaging system is preferably formed by attaching, as for instance by adhesive bonding, the absorbent web 310 to a sheet 312 of clear polypropylene and the cassette 302 positioned thereon (see FIG. 22). The sheet 312 and web 310 are wrapped around the cassette 302 and edges thereof attached to form a seal 314.

10           The absorbent web 310 is preferably fire resistant and preferably forms no hazardous reactions with the sterilant. The amount of superabsorbent polymer is preferably sufficient to absorb all of the sterilant within the cassette and retain it without release even under externally applied pressure of 2 or 3 pounds per square inch. A sleeve as in the previous embodiment can be employed, but is preferably formed of a material  
15           which also is fire resistant and forms no hazardous reactions with the sterilant. A color change indicator showing the presence of sterilant is present within the outer wrap 304 and visible therethrough to warn a user not to open the wrap if sterilant has leaked out of the cassette 302. When using a sterilant in solution with water, the indicator can indicate the presence of the water, such as the ULTRA THIN WATER CONTACT INDICATOR  
20           TAPE 5559 available from 3M.

          While the invention has been particularly described in connection with specific embodiments thereof, it is to be understood that this is by way of illustration and not of limitation, and that the scope of the appended claims should be construed as broadly as the  
25           prior art will permit.

2005201907 05 May 2005

The claims defining the invention are as follows:

1. A cassette for a sterilizer, the cassette comprising:  
a body;

5 one or more cells in the body, at least one of the one or more cells containing a  
quantity of liquid sterilant; and

a bar code associated with the cassette, the bar code having encoded therein a  
lumen claim.

10 2. A cassette according to claim 1 wherein the bar code has encoded therein an  
identifier for a type or model of sterilizer to which the lumen claim is related.

3. A cassette according to claim 1 wherein the sterilant comprises hydrogen  
peroxide solution.

15

4. A cassette according to claim 1 wherein the lumen claim specifies a length  
and internal diameter of a lumen.

20

5. A cassette according to claim 4 wherein the lumen claim specifies a  
material from which the lumen is constructed.

6. A cassette according to claim 1 wherein the bar code has encoded therein a  
length and an internal diameter for the lumen claim.

25

7. A cassette according to claim 6 wherein the bar code has encoded therein a  
material for the lumen claim.

8. A cassette according to claim 1 wherein the bar code is on label attached to  
the body.

30

9. A cassette according to claim 1 wherein the bar code is printed onto the  
body.

10. A cassette according to claim 1 comprising a plurality of the cells.

11. A cassette according to claim 1 and further comprising a sleeve about the body and wherein the bar code is on the sleeve.

5 12. A cassette for a sterilizer, substantially as hereinbefore described with reference to the accompanying drawings.

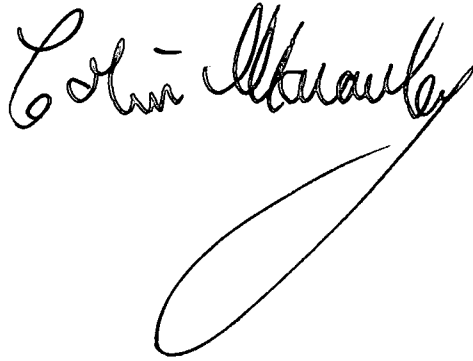
Dated this 4<sup>th</sup> day of May, 2005

10

**ETHICON, INC.**

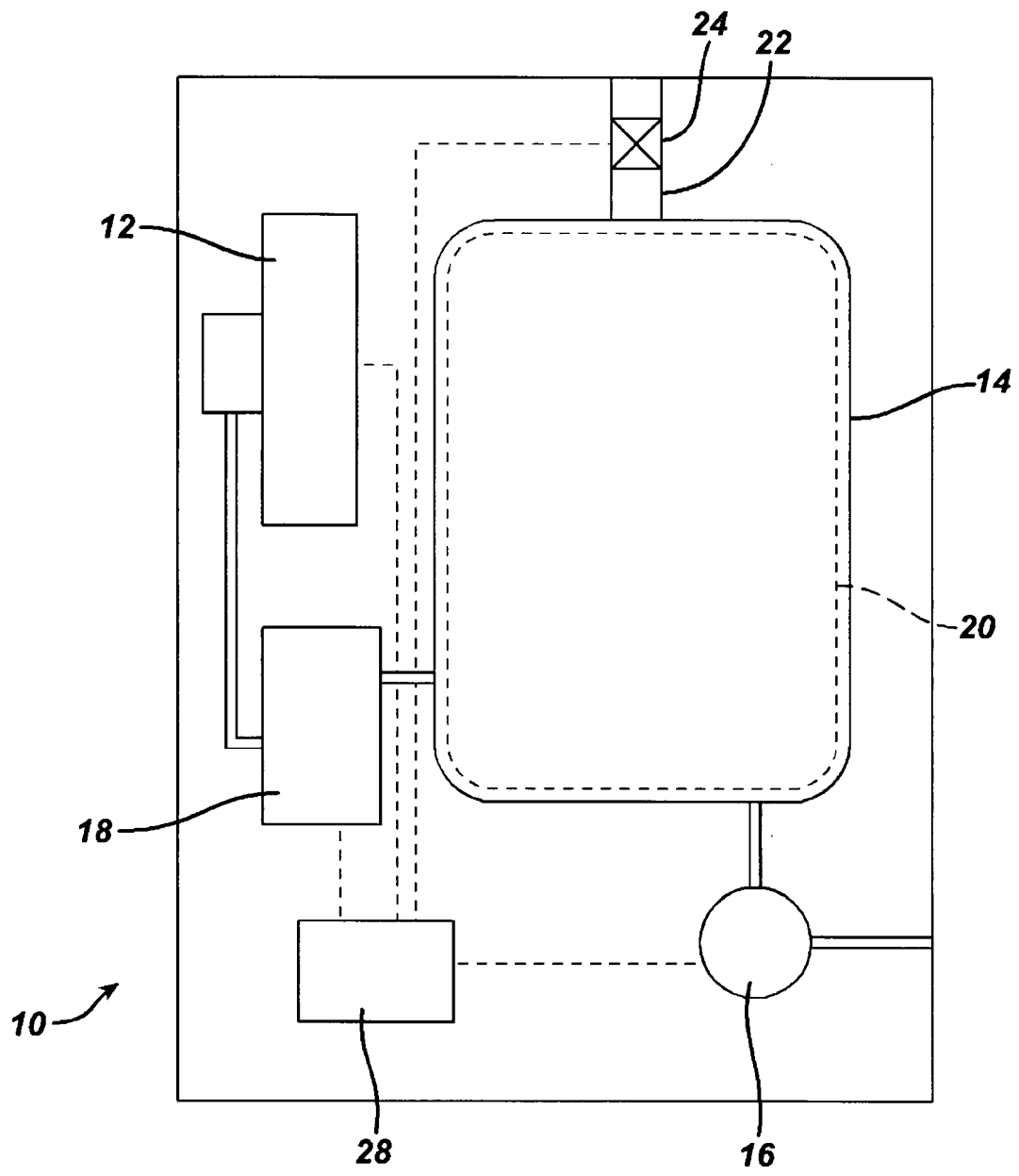
By Their Patent Attorneys

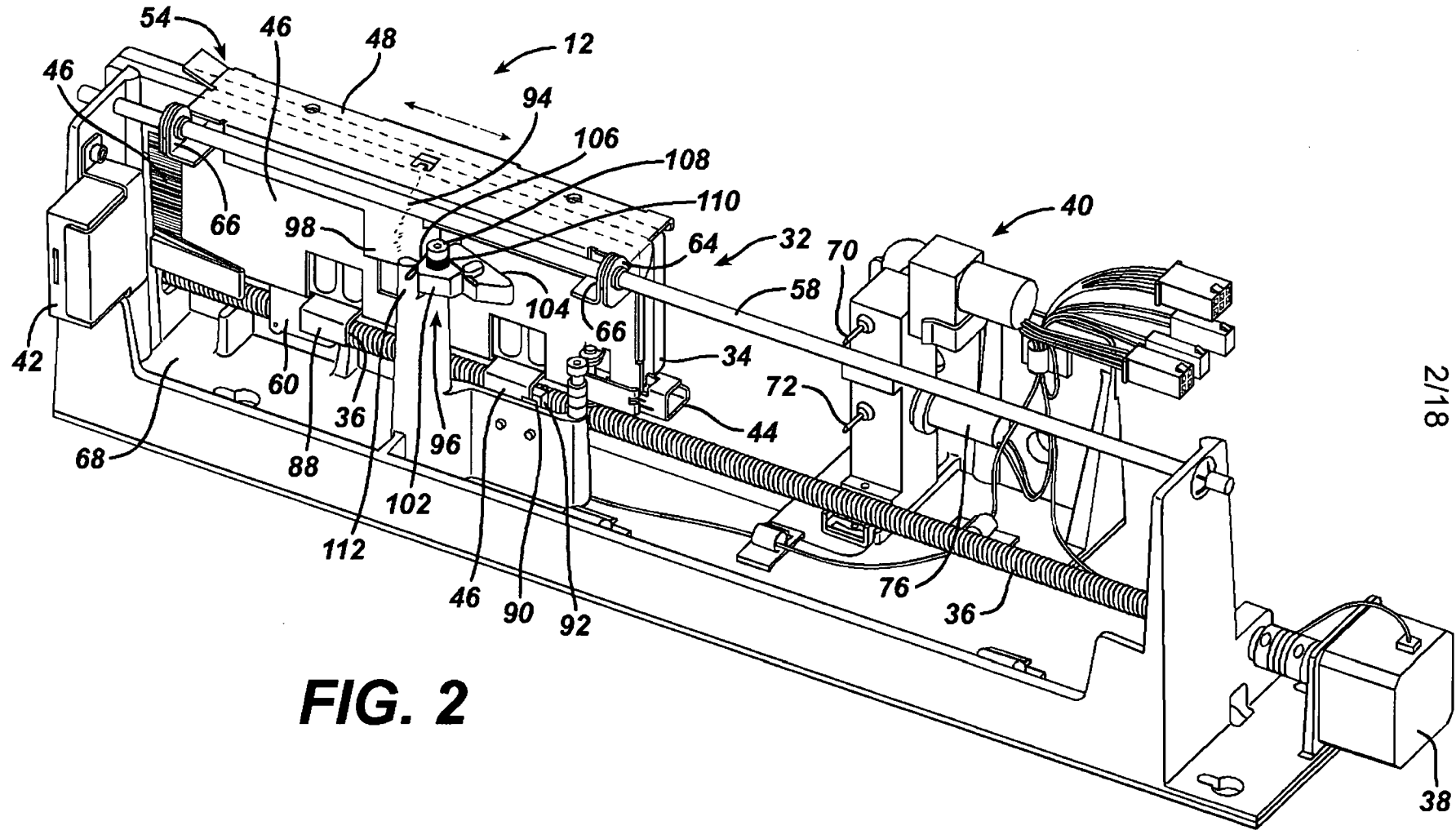
CALLINAN LAWRIE

A handwritten signature in cursive script, appearing to read "Colin Murray". The signature is written in black ink and is positioned below the printed name of the patent attorneys.

2005201907 05 May 2005

**FIG. 1**

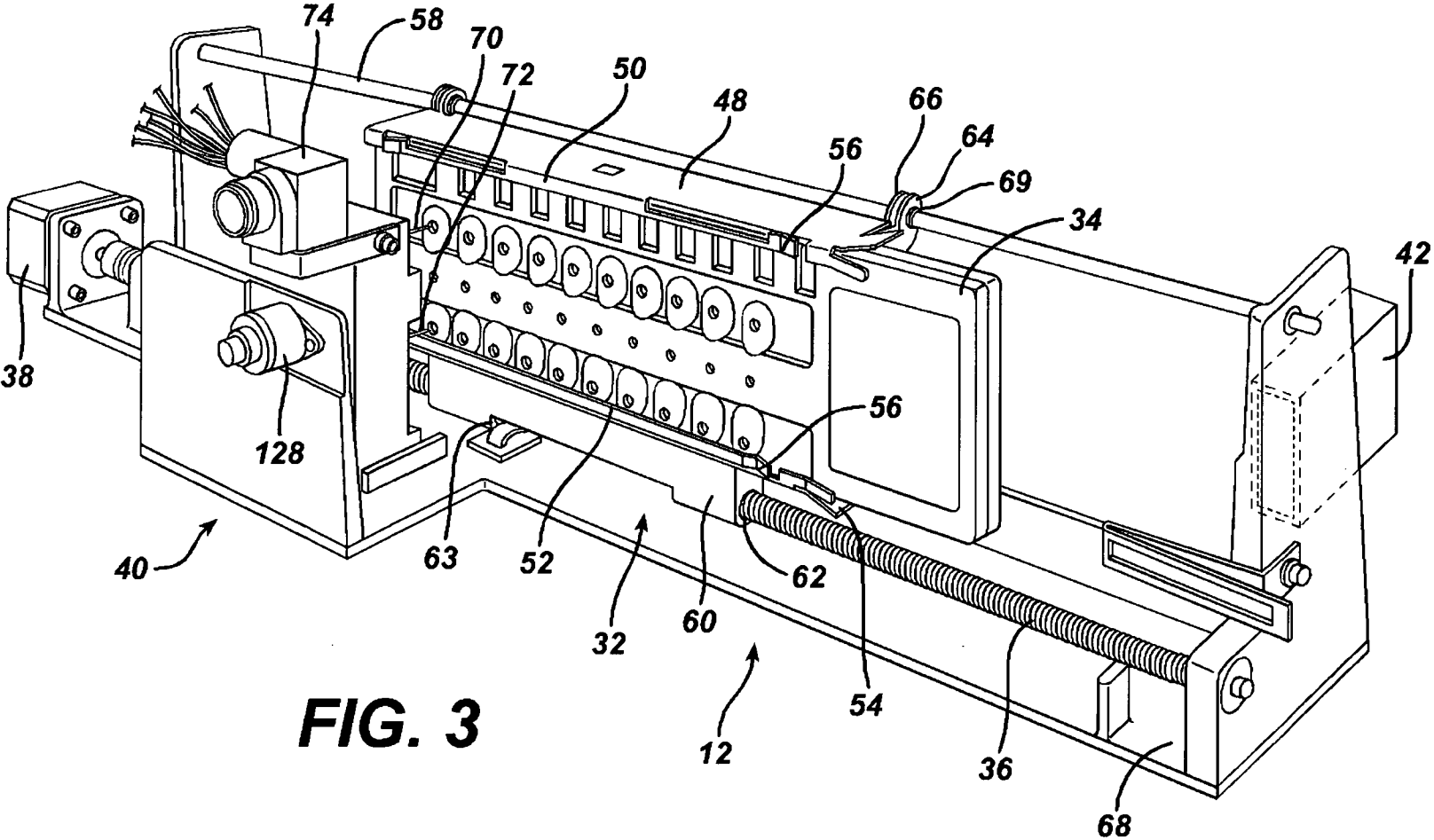




**FIG. 2**

2/18

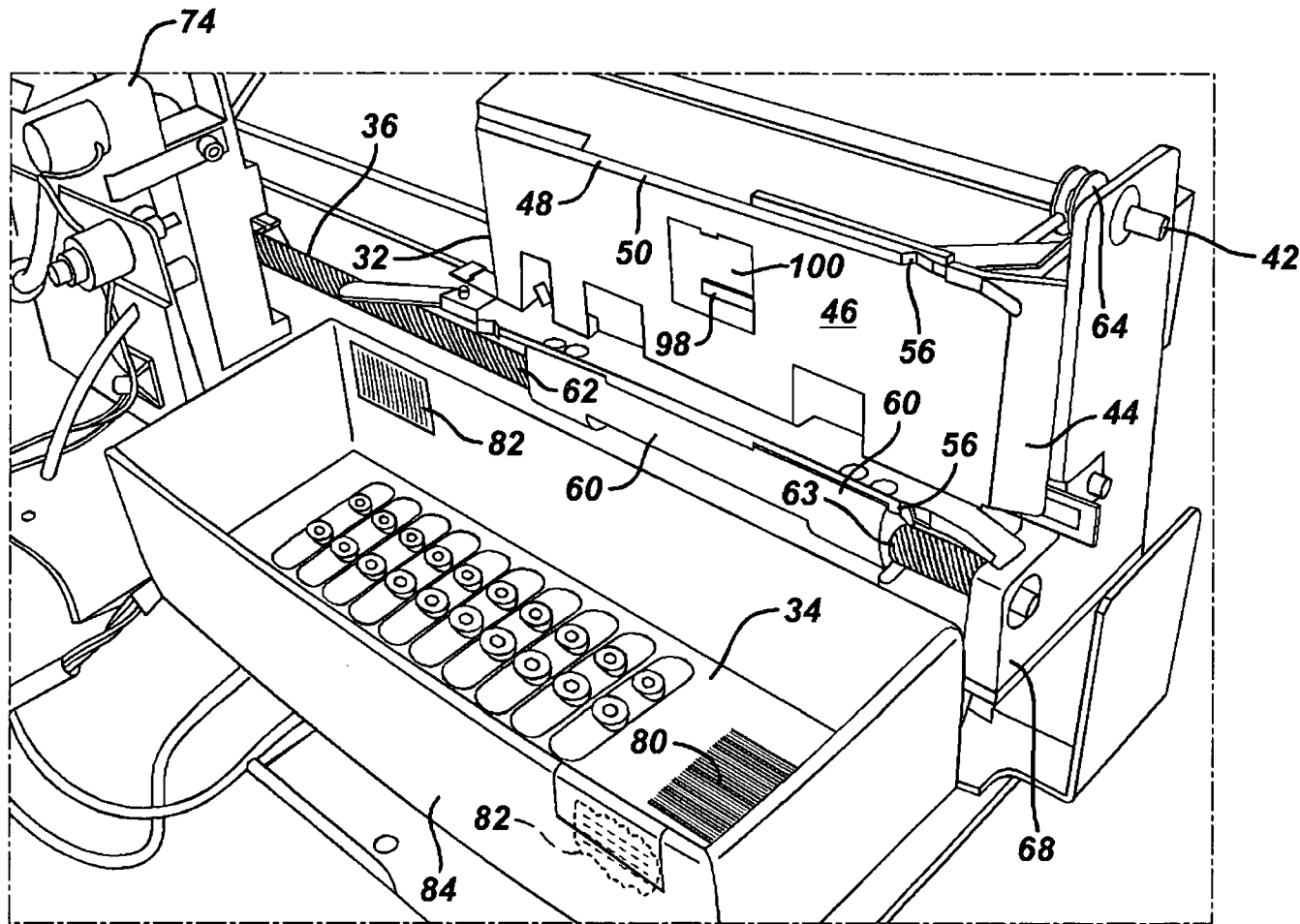
38



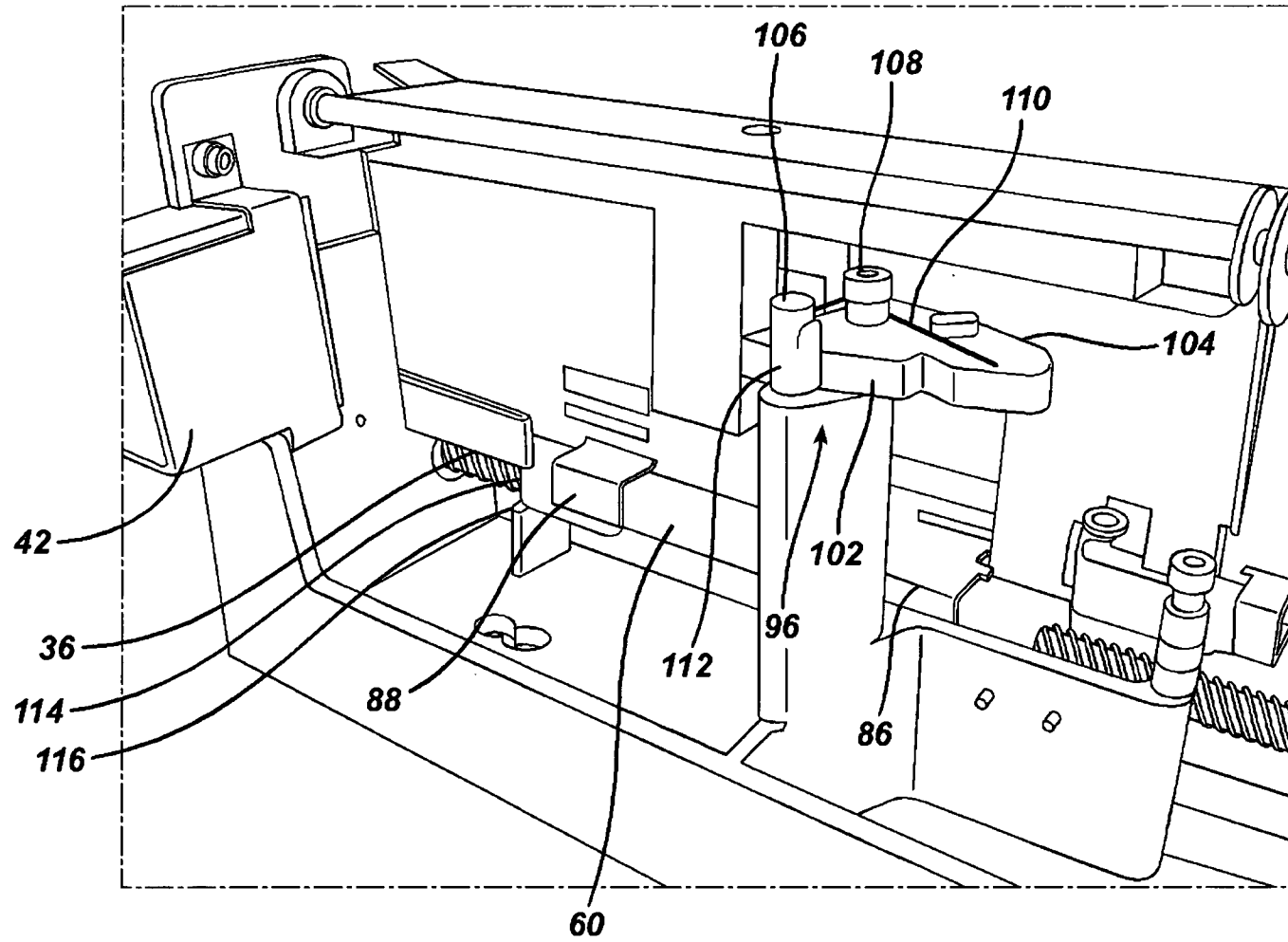
**FIG. 3**

3/18

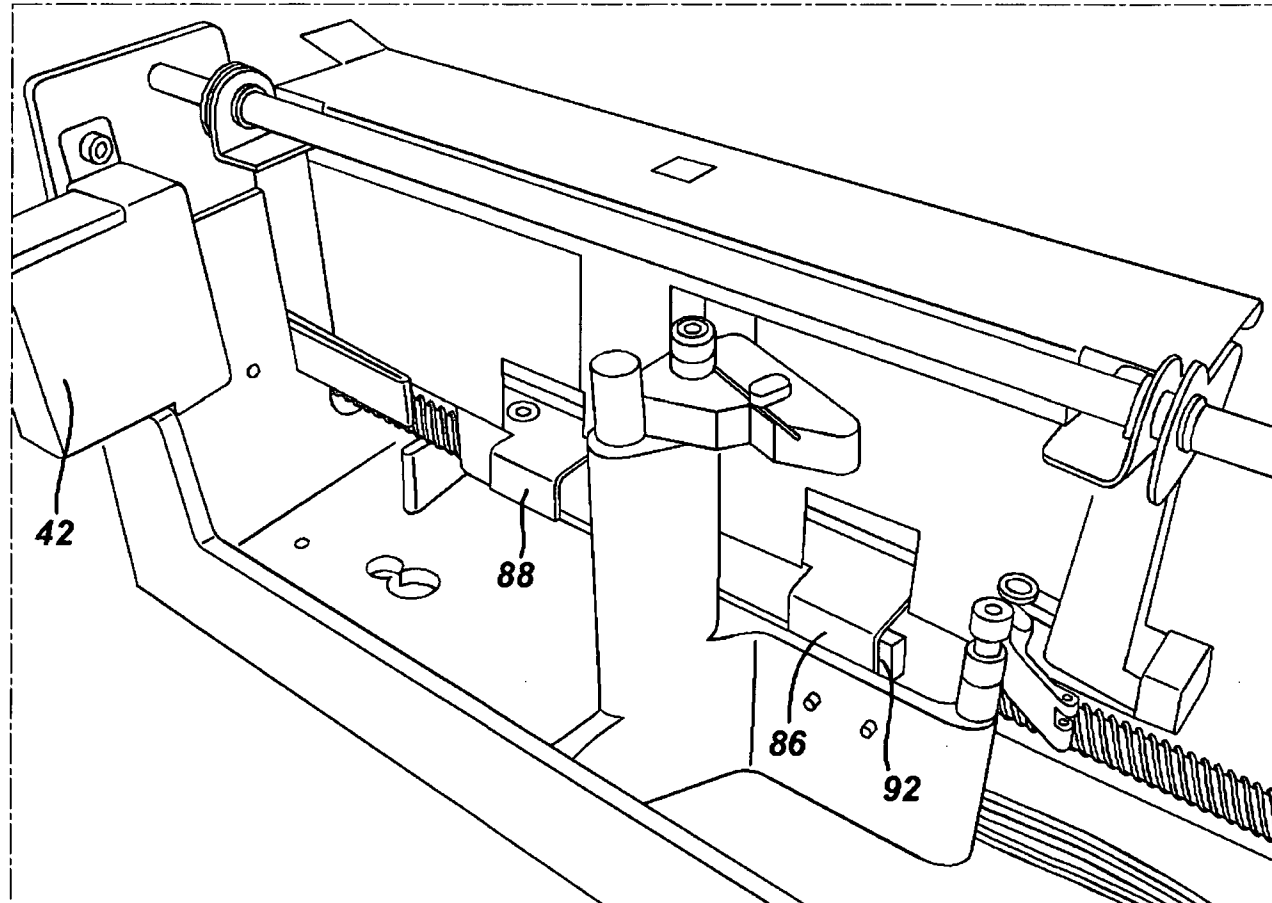
**FIG. 4**



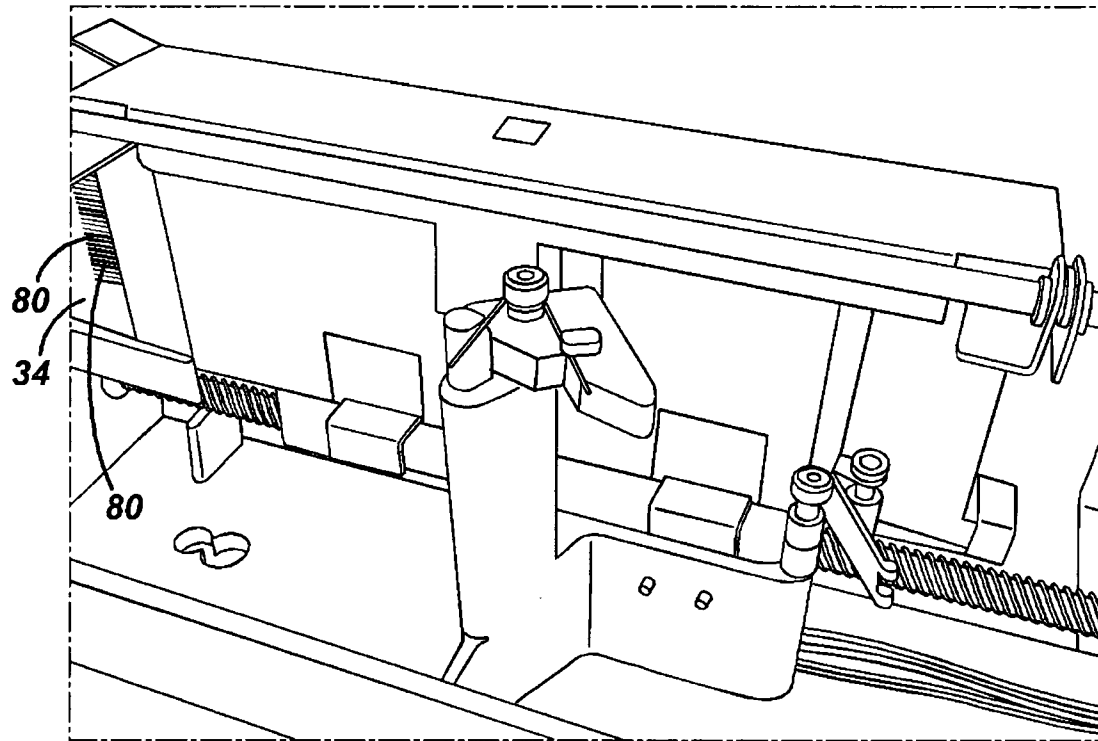
**FIG. 5**



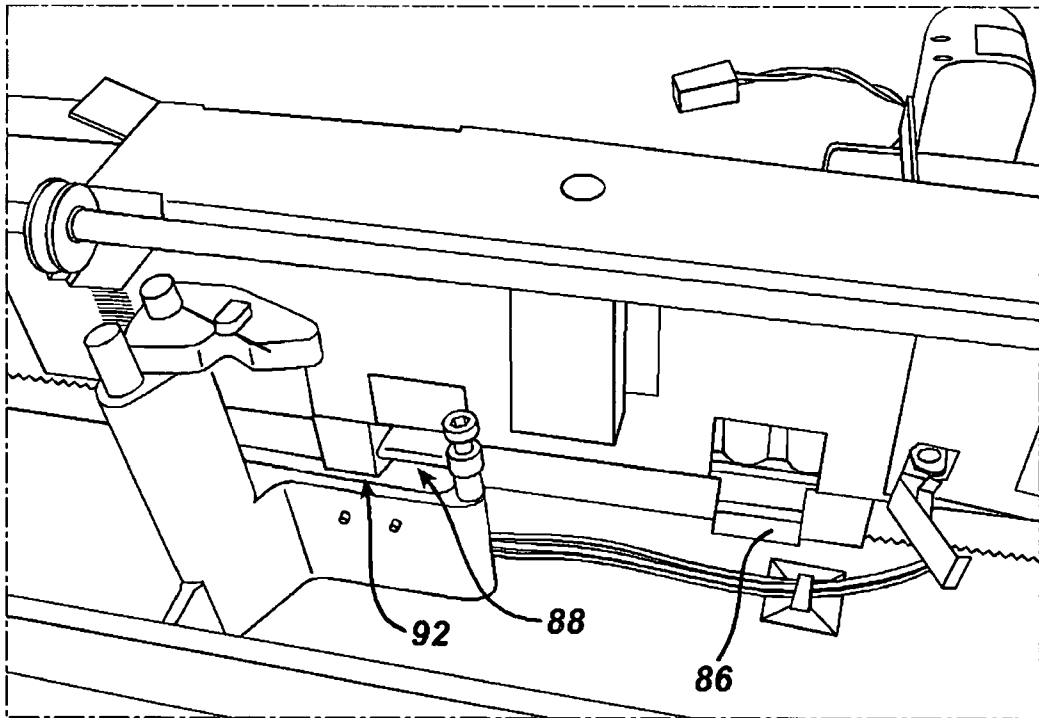
**FIG. 6**

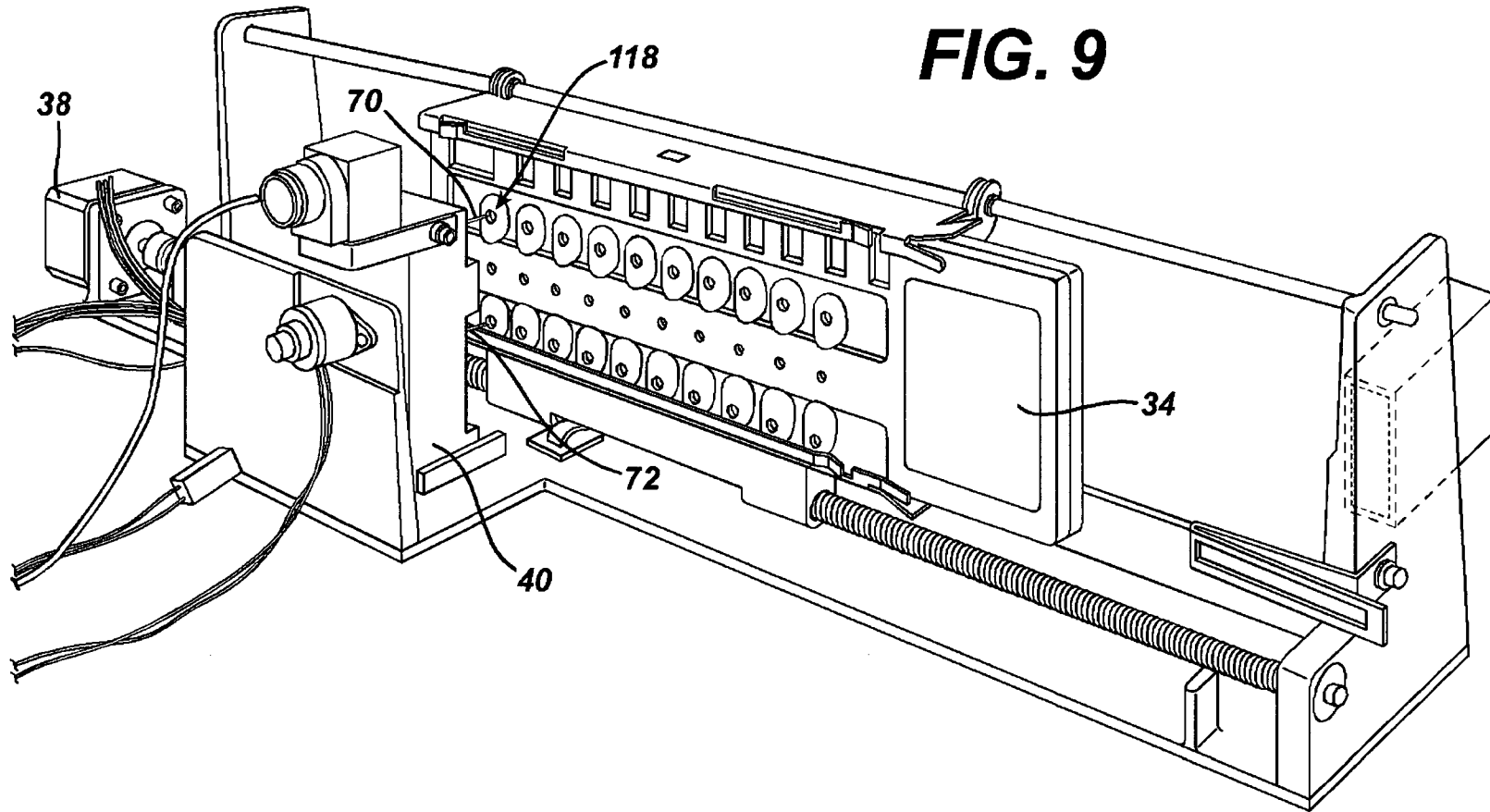


**FIG. 7**



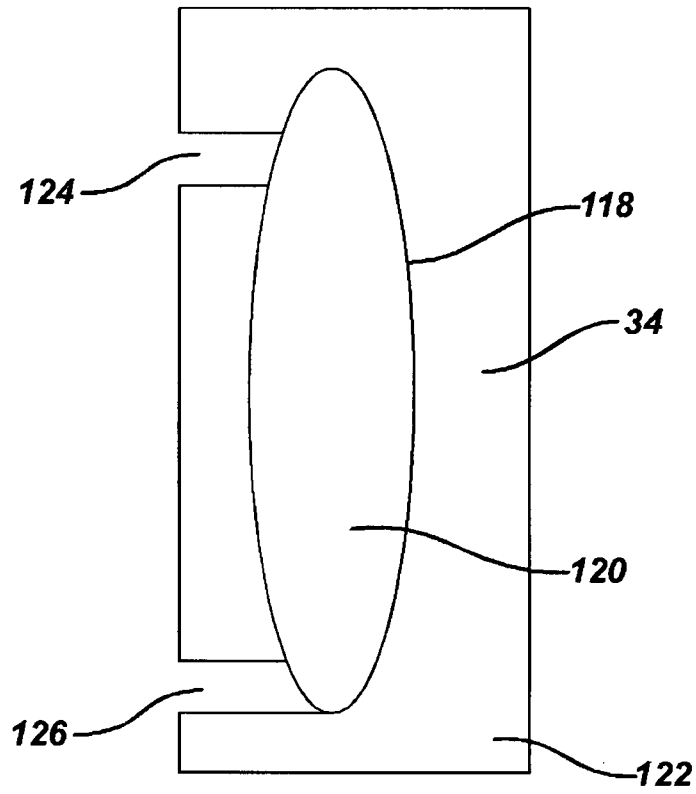
**FIG. 8**



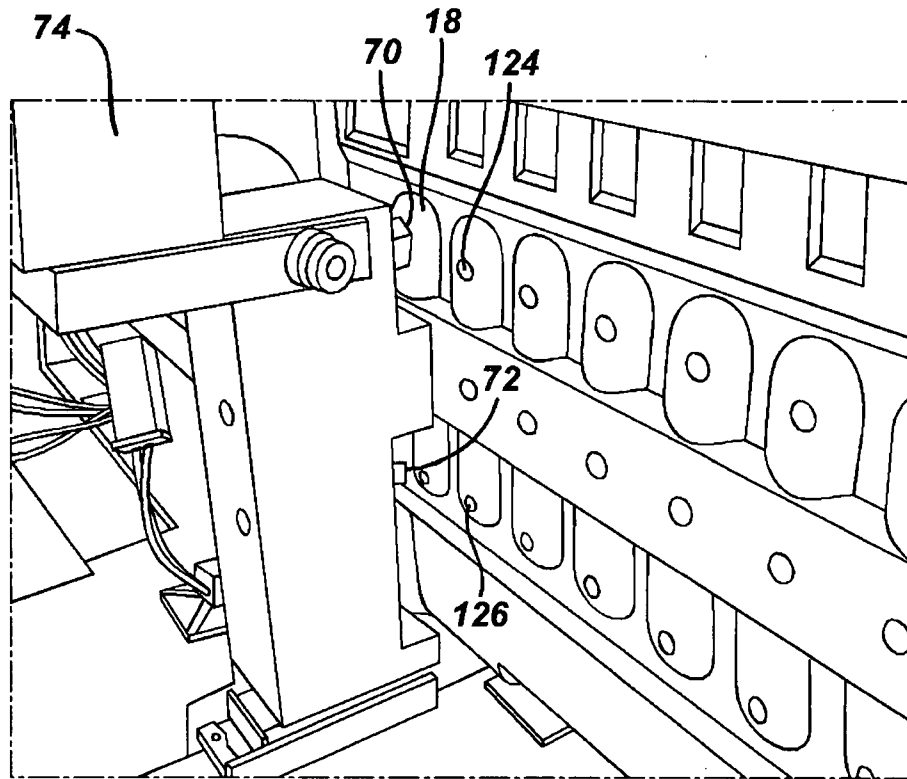


9/18

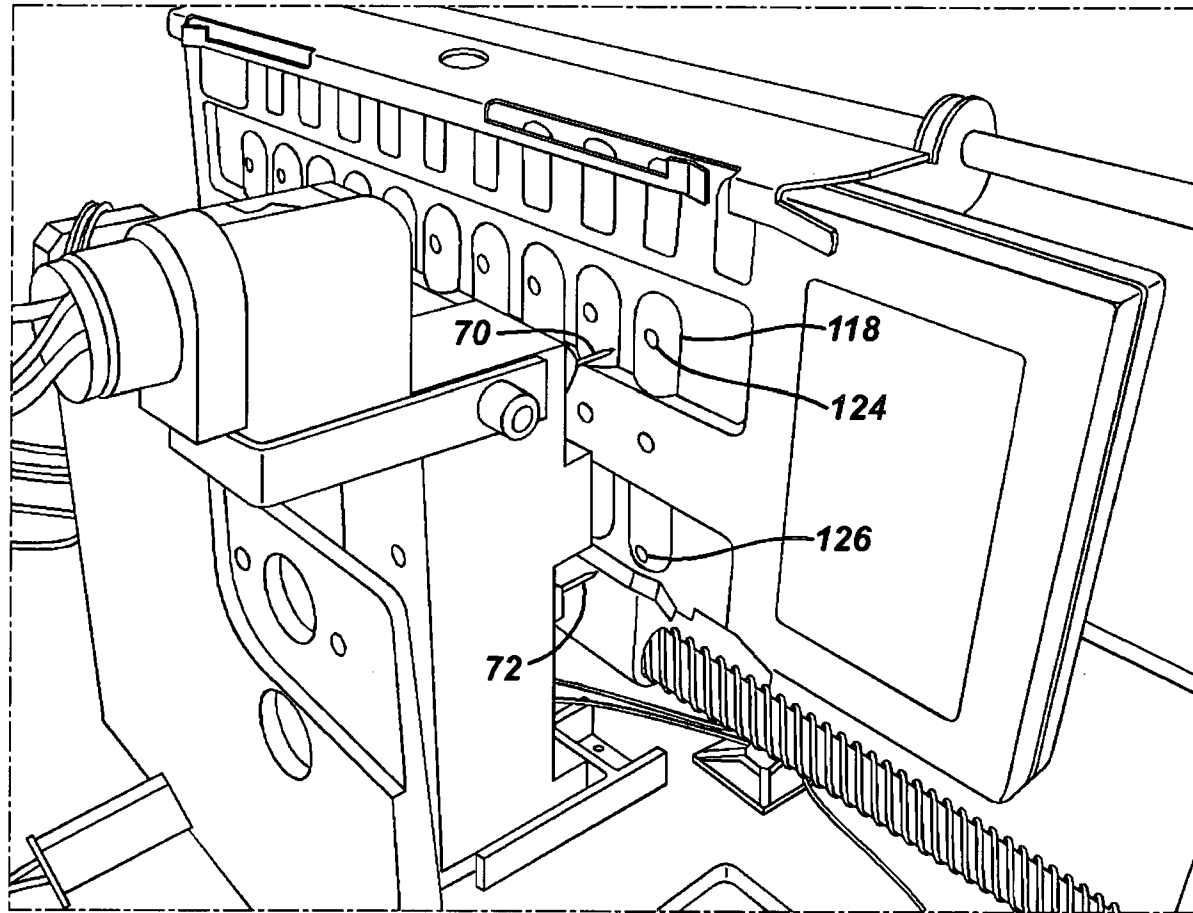
**FIG. 10**



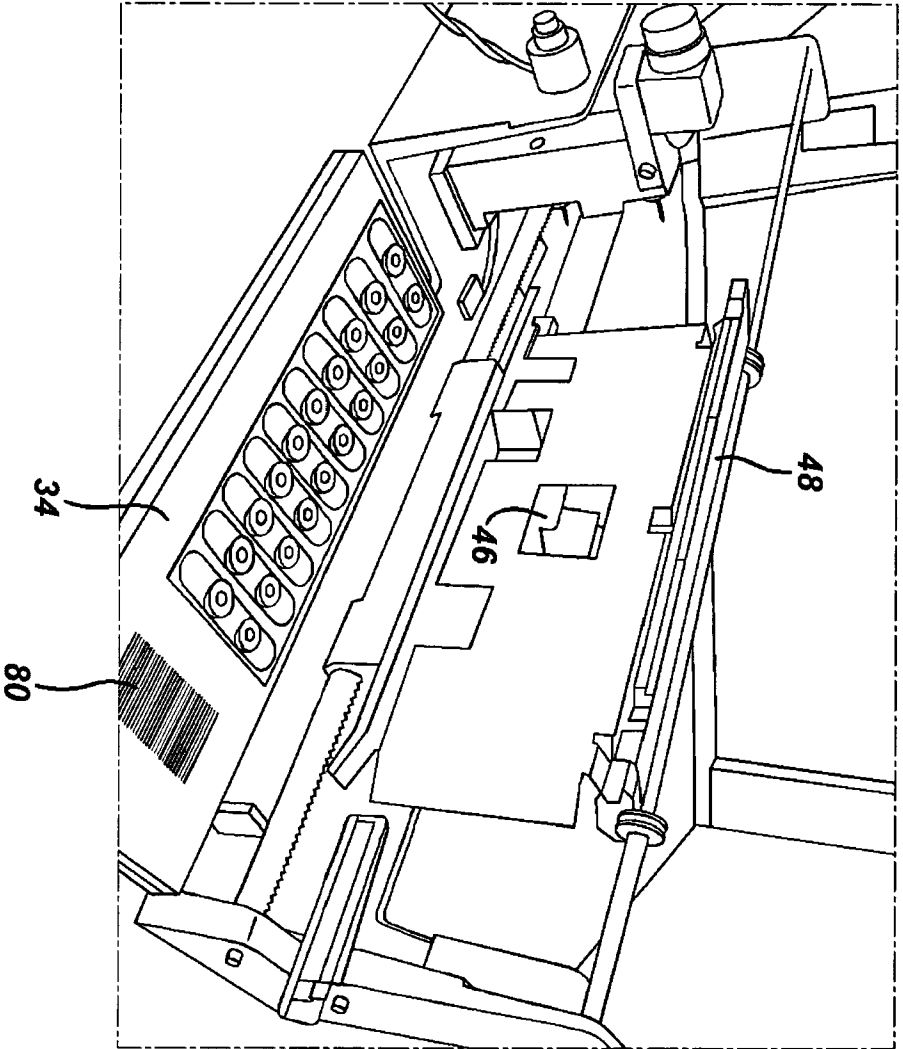
**FIG. 11**



**FIG. 12**

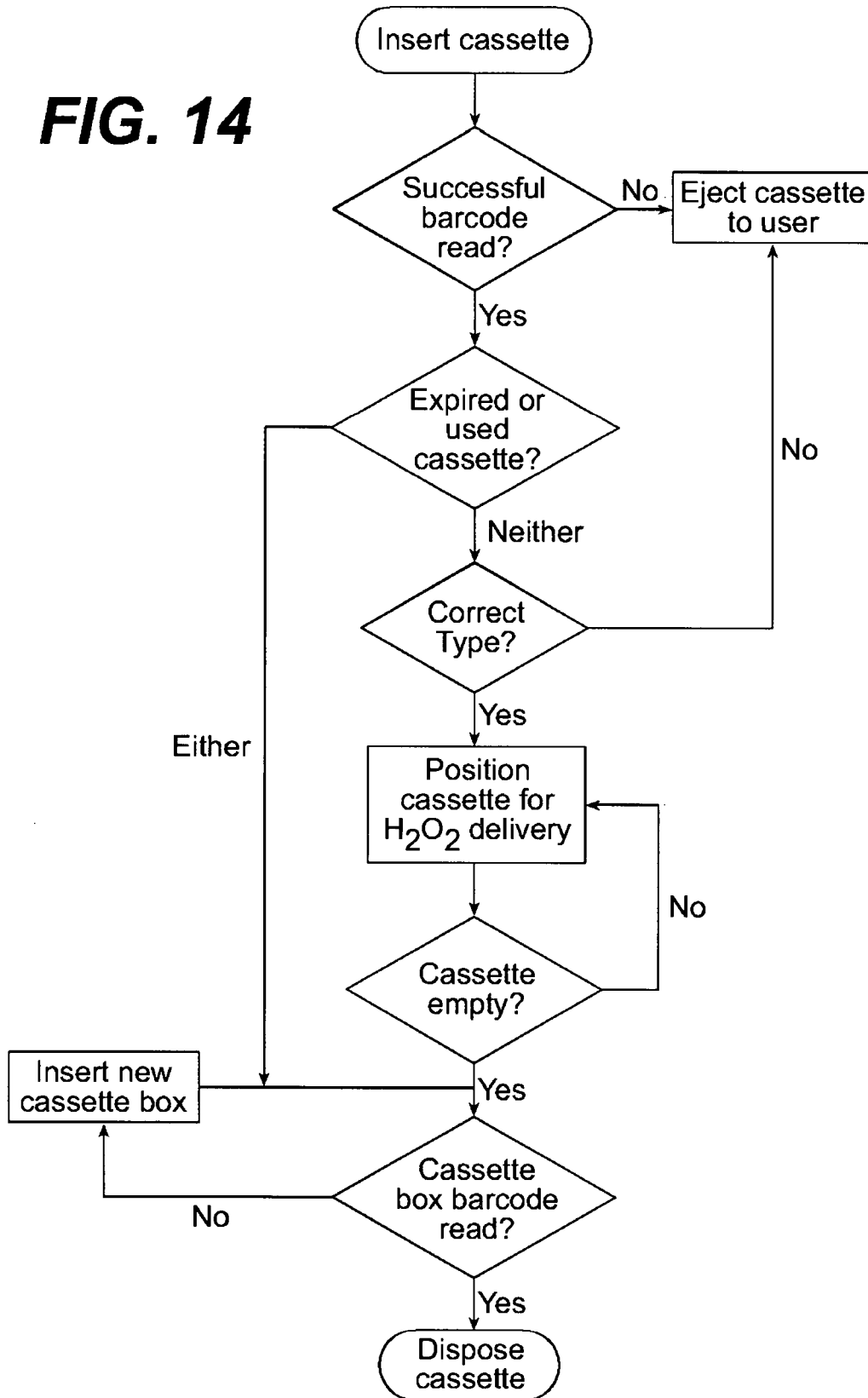


12/18

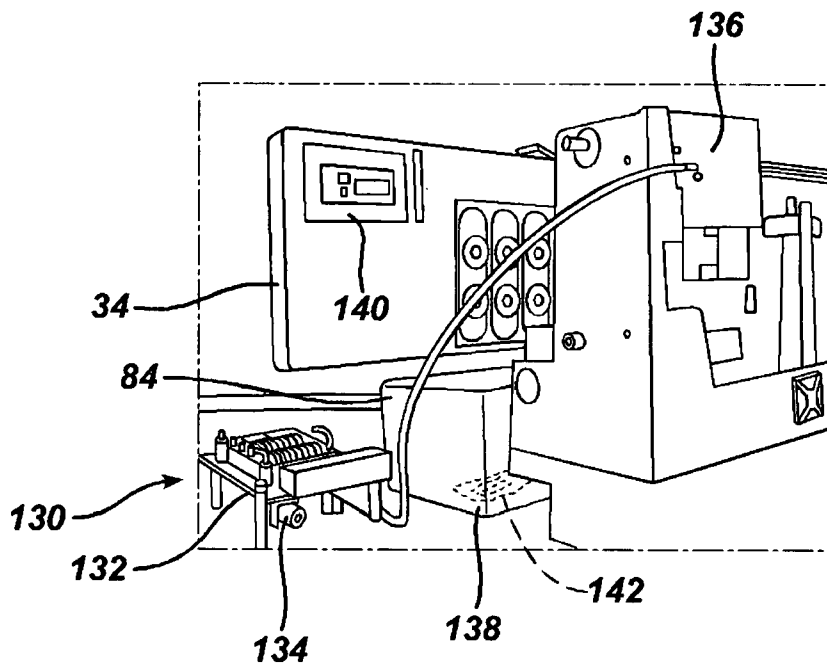


**FIG. 13**

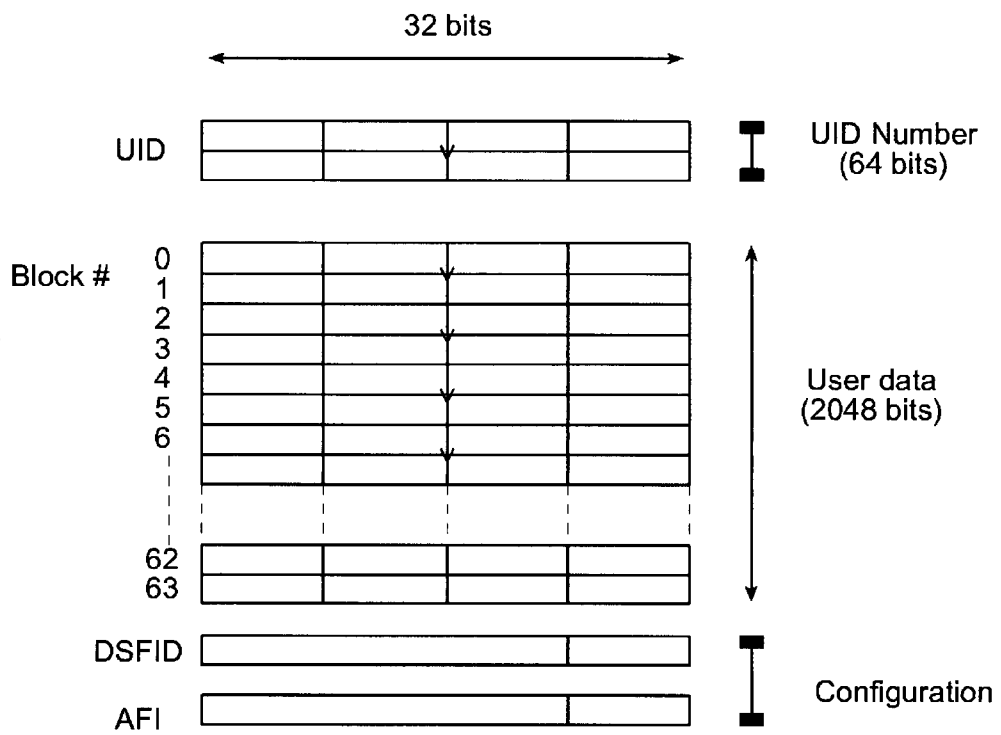
**FIG. 14**



**FIG. 15**



**FIG. 16**





**FIG. 18**

