



(51) International Patent Classification:

A45D 34/04 (2006.01) A61H 7/00 (2006.01)  
A46B 11/00 (2006.01) A61H 15/00 (2006.01)  
A46B 13/02 (2006.01)

(21) International Application Number:

PCT/EP2013/077591

(22) International Filing Date:

20 December 2013 (20.12.2013)

(25) Filing Language:

English

(26) Publication Language:

English

(30) Priority Data:

1262724 21 December 2012 (21.12.2012) FR

(71) Applicant: L'OREAL [FR/FR]; 14, rue Royale, F-75008 Paris (FR).

(72) Inventor: THIEBAUT, Laure; 10 rue de l'abreuvoir, F-92110 Clichy (FR).

(74) Agent: BOURDEAU, Françoise; L'OREAL, D.I.P.I., 25-29 Quai Aulagnier, F-92665 ASNIERES-SUR-SEINE Cedex (FR).

(81) Designated States (unless otherwise indicated, for every kind of national protection available): AE, AG, AL, AM,

AO, AT, AU, AZ, BA, BB, BG, BH, BN, BR, BW, BY, BZ, CA, CH, CL, CN, CO, CR, CU, CZ, DE, DK, DM, DO, DZ, EC, EE, EG, ES, FI, GB, GD, GE, GH, GM, GT, HN, HR, HU, ID, IL, IN, IR, IS, JP, KE, KG, KN, KP, KR, KZ, LA, LC, LK, LR, LS, LT, LU, LY, MA, MD, ME, MG, MK, MN, MW, MX, MY, MZ, NA, NG, NI, NO, NZ, OM, PA, PE, PG, PH, PL, PT, QA, RO, RS, RU, RW, SA, SC, SD, SE, SG, SK, SL, SM, ST, SV, SY, TH, TJ, TM, TN, TR, TT, TZ, UA, UG, US, UZ, VC, VN, ZA, ZM, ZW.

(84) Designated States (unless otherwise indicated, for every kind of regional protection available): ARIPO (BW, GH, GM, KE, LR, LS, MW, MZ, NA, RW, SD, SL, SZ, TZ, UG, ZM, ZW), Eurasian (AM, AZ, BY, KG, KZ, RU, TJ, TM), European (AL, AT, BE, BG, CH, CY, CZ, DE, DK, EE, ES, FI, FR, GB, GR, HR, HU, IE, IS, IT, LT, LU, LV, MC, MK, MT, NL, NO, PL, PT, RO, RS, SE, SI, SK, SM, TR), OAPI (BF, BJ, CF, CG, CL, CM, GA, GN, GQ, GW, KM, ML, MR, NE, SN, TD, TG).

Published:

- with international search report (Art. 21(3))
- before the expiration of the time limit for amending the claims and to be republished in the event of receipt of amendments (Rule 48.2(h))

(54) Title: BELLOWS END PIECE FOR COSMETIC DEVICE

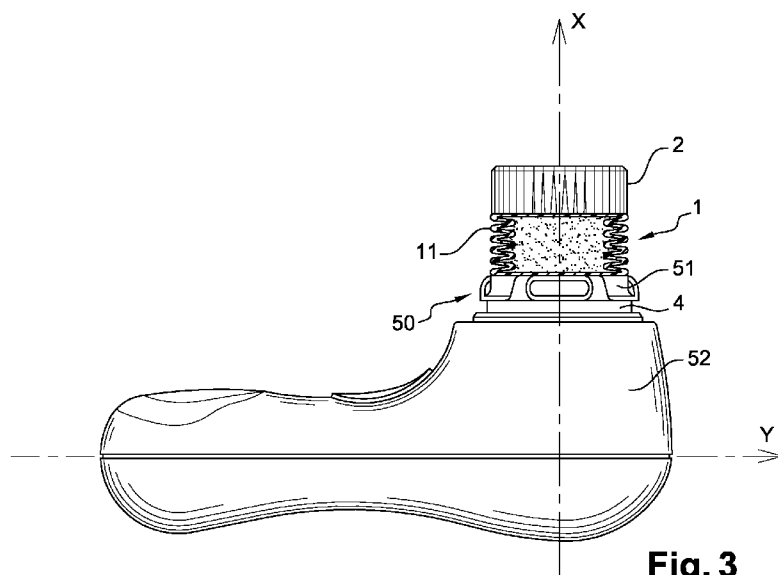

(57) Abstract: The present invention relates to an end piece for a device for dispensing and applying a cosmetic composition, having: - a reservoir (1) containing the cosmetic composition, - an applicator (2), - a means (3) for the composition to pass between the reservoir (1) and the applicator (2), the reservoir (1) having a region (11) that is deformable under the effect of a pressure exerted on the applicator (2).

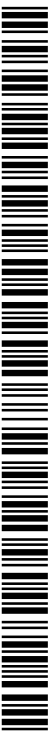

## Bellows end piece for cosmetic device

The subject of the present invention is an end piece for a device for dispensing and applying a cosmetic composition.

5 The application of a cosmetic composition with the aid of an assembly comprising an aerosol container and a device to be mounted on the aerosol container, comprising a rotating massaging member driven by an electric motor, is known from EP 1 728 494.

10 Document FR 2 918 545 also discloses an assembly for dispensing and applying a cosmetic composition, comprising:

- a container containing the composition, the latter comprising at least one cosmetic active agent selected from: a cleansing or makeup removal agent, an anti-aging active agent, an antiwrinkle active agent, an antioxidant, a lipo-restructuring agent, an agent for promoting cutaneous microcirculation, an active agent for combating oily skin, a self-tanner, a desquamation product, a humectant or moisturizing agent, a surfactant, an active agent for the contour of the eyes, a slimming agent,

- an applicator,

- an application device comprising:

20 - a body configured to receive the container and the applicator,  
- a means for rotating the applicator relative to the body, and  
- a duct for conveying the composition from the receptacle towards an application surface of the applicator.

The rotation can make it possible to carry out at least one of a massaging action, a skin exfoliation action, and a composition spreading action, which can generate new sensations on application and can improve the effect of one or more active agents.

25 However, according to said document, no provision is made to easily change the container containing the composition and to replace it, for example with a container containing a different composition. In addition, said document does not provide the possibility of delivering a quantity of product determined by the user himself.

30 Documents FR2779923, US5186563, US6805512, US D498021 and DE 19963138 describe reservoirs having an end piece which are used manually without being coupled to an electrical appliance for setting this end piece in motion.

There exists a need to provide an end piece for devices for dispensing and applying cosmetic products, which is:

- practical to use,
- of simple construction,
- 5 - without the need to empty the ducts in order to be changed,
- precise in terms of dosing as per the desires of the user,
- capable of providing the consumer with the possibility of changing the cosmetic product while retaining the same device, under appropriate hygienic conditions.

To this end, the subject of the invention is an end piece for a device for  
10 dispensing and applying a cosmetic composition, having:

- a reservoir containing the cosmetic composition,
  - an applicator,
  - a means for the composition to pass between the reservoir and the applicator,
- the reservoir having a region that is deformable under the effect of a pressure exerted on  
15 the applicator.

The end piece may also be known as a "*refilling*" or "*replacement end piece*".

With the end piece of the invention, the user does not have to carry out excessive manipulations. She simply fits the end piece on the device and then she can press the end piece against the body surface to a greater or lesser extent. Depending on the  
20 pressure that she exerts, she alters the quantity of product delivered on the surface. Of course, she may choose to apply the product several times, in particular depending on the degree of absorption of her skin for example or depending on the evaporation of the product.

The end piece has a simple construction, giving it an affordable cost.

25 A significant advantage of the end piece of the invention lies in the fact that the product is delivered directly by pressure on the surface treated. Thus, the delivery of the product is precise both in terms of quantity and in terms of position. Since the dispensing of the product does not require the pressure of a finger, the end piece may be used even by less dexterous, shaking or elderly people.

30

#### Deformable region

Advantageously, the deformable region is an axially deformable region.

An "*axially deformable region*" is understood to mean a region that is deformable along the longitudinal axis X of the end piece.

The compression of the deformable region generally results from the user pushing approximately along the axis of the deformable region, said axis being coincident  
5 with the axis X.

By virtue of the invention, the user can easily obtain a dose of product in a simple manner. The user can decide to push the deformable region down to the maximum extent. He can also choose to apply pressure to the compressible region to a greater or lesser extent.

10 The user can also easily use the end piece with one hand.

Advantageously, the deformable region comprises a bellows.

The bellows is an elastic member which relaxes when it is not subjected to any compressive stress along its axis. It is compressed in the event of axial stress.

The deformable region comprises a first region and a second region that are  
15 moved toward one another during its compression, the compression resulting from the user pushing approximately along the axis of the body of the device.

The thickness of the bellows is for example between 0.1 mm and 1 mm, and preferably between 0.3 mm and 0.8 mm.

Advantageously, the number of folds in the bellows may be between two and  
20 six, better still between three and five.

### Reservoir

Advantageously, the reservoir is formed in one piece.

It is preferably molded in one piece, in particular from the same thermoplastic  
25 material, for example LDPE, HDPE, a mixture of LDPE and HDPE, PP or a mixture of PE and PP in any desired proportion. The thickness of the wall of the reservoir is for example between 0.1 and 1 mm and between 0.3 and 0.8 mm in the second region.

Advantageously, the cosmetic product initially takes up from 70 to 100% of the internal volume of the deformable region.

30 The term "*initially*" is understood to mean prior to first use of the end piece.

The body of the reservoir may be surmounted by a neck for fastening a cap, in order to store the end piece.

If need be, the reservoir is closed by a cap so as to seal it. It is proposed for the user to fit the reservoir on an application device, after removing the cap, on first use.

Advantageously, the applicator is fitted on the neck of the reservoir and the cap is fitted on the applicator so as to close off the means for the composition to pass  
5 between the reservoir and the applicator, for example the dispensing orifices.

Advantageously, the overall internal volume of the reservoir is between 1 and 100 cm<sup>3</sup>, preferably between 20 and 50 cm<sup>3</sup>, in the rest configuration of the deformable region. This volume is optimal for several uses or repeated treatment extending over several weeks.

10 Preferably, the internal volume of the reservoir can retract by a volume of between 10% and 50% of the internal volume of said reservoir in the rest configuration of the deformable region. This variation in volume has the advantage of being visible and measurable.

Advantageously, the reservoir is defined by a ratio  $L/l$  which is greater than or  
15 equal to 2,  
L being the length of the end piece in the rest configuration of the deformable region, and  $l$  being the greatest transverse dimension of the end piece in the rest configuration of the deformable region.

These dimensions give it a practical appearance and make it easy to store.

20 The reservoir may be manufactured by injection blow molding or extrusion blow molding.

#### Applicator

The applicator may comprise a cellular material which may be elastically  
25 deformable and/or compressible. This material may be a foam. The foam may be produced from a material selected from the following list: polyurethane, polyether, polyester, polyvinyl chloride, polyethylene, EVA, latex, silicone, SIS, SEBS, silicone elastomer, latex elastomer, nitrile elastomer, butyl elastomer, Neoprene<sup>®</sup>, NBR, SBR, this list not being limiting.

30 The applicator may have a composite structure having a plurality of layers having different natures, for example a number of types of foam. The applicator may comprise a slot or a hole opening onto the application surface.

The applicator may have any shape. It may have a circular, oval or polygonal cross section, for example a triangular, square, hexagonal, etc. cross section.

The applicator may have abrasive properties. "Abrasive property" should be understood as meaning a surface which, when moved over the skin, removes at least some  
5 of the dead cells from the surface.

Such surfaces can be characterized by an abrasive power of between 0.01 and 0.03 g/cm<sup>2</sup>/min. The abrasive power corresponds to the quantity of plaster removed per minute, per square centimeter of an abrasive surface applied to a square of plaster having a thickness of 50 mm using a 135W Black and Decker CD 400 sander, the pressure exerted  
10 on the square of plaster resulting from the weight of the sander, only the movement of which in the plane of the abrasive surface is constrained.

Such applicators are obtained either by taking a substantially rigid cellular material, or by incorporating hard grains into a flexible cellular material.

An example of an abrasive surface is a nonwoven exfoliating pad sold by 3M.

The foam may be a soft and flexible foam particularly suitable for spreading  
15 the product, sometimes also known as a sponge.

The applicator may be for example a hydrophilic crosslinked polyester foam, for example having a density equal to 32 kg/m<sup>3</sup>.

A sponge traditionally used for applying foundation, such as NBR, for  
20 example Yukilon<sup>®</sup> from Penthouse Group is also conceivable.

The applicator may be made of flexible injection-molded plastics material, for example of elastomer, and have massaging reliefs, for example spikes or balls.

The applicator is for example made of an elastomer such as SEBS or silicone.

The applicator may be a thermocompressed foam. Thermocompression makes  
25 it possible to create reliefs on the surface of the foam and/or to complex it with an elastic fabric, thereby making it possible to have the flexibility of the foam but the feel of a textile more pleasant than that of plastic.

An example of a thermocompressed foam is a closed-cell foam made of polyolefin, for example thermocompressed polyethylene having a specific weight of 33  
30 kg/m<sup>3</sup>, which is for example complexed with an elastic fabric such as for example Lycra<sup>®</sup>.

The applicator may be a file made of plastics material, metal or glass.

The applicator may be a brush made of synthetic or natural bristles, for example a bristled brush having tufts of strands of Nylon<sup>®</sup> 6.12 having a diameter of 0.075 mm, which have been milled and ground in order to make them very soft in contact with the skin of the face.

5 The applicator may have elements that are able to rotate, such as balls or rollers, which are smooth or have reliefs in order to massage the skin.

The invention also relates to a device for dispensing and applying a cosmetic composition contained in an above end piece, said device having a housing for receiving the end piece.

10 Advantageously, the device has a means for setting the end piece in motion. Generally, the applicator is set in motion by the entire end piece being set in motion.

Advantageously, the device comprises electrical supply means.

#### 15 Dispensing and application devices

A number of types of device can be used depending on the way in which they move. These are known to a person skilled in the art. Examples are:

##### a) Simple movement:

- Rotary movement
- 20 • Oscillating movement
- Rotary movement that can be reversed by the user in order to provide a massage or upward traction of the skin
- Percussive movement
- Vibratory movement

##### 25 b) Composite movement:

- Rotary movement associated with percussion
- Rotary movement associated with vibration

#### Fixing the end piece onto the device

30 It is easier to fit the end piece since the latter may, for example, simply be inserted into a corresponding housing in the device.

The device may have a casing having an elongate shape, provided at one end with at least one control member for setting the end piece in motion.

The device may have at least two housings for receiving at least two end pieces.

5 The device may have a separate control member for each end piece or a selection means for selecting an end piece prior to actuating the control member.

Advantageously, the end piece is secured to the housing of the device by pinching, snap-fastening, clip-fastening, screwing, clamping, force-fitting or magnetization.

10 The end piece may also have coupling tabs intended to be snap-fastened to the application member in order to retain the reservoir and the applicator.

The tabs are generally sufficiently flexible to allow the user to disconnect the applicator 5 by pulling thereon.

15 Passage of the composition between the reservoir and the applicator

The reservoir and the applicator may be separated by at least one wall having one or more through-orifices. The through-orifice or through-orifices form(s) one or more duct(s) for the composition to pass through.

20 The passage duct makes it possible to convey the composition leaving the reservoir towards the applicator and then towards the body surface to be treated.

The passage duct may also be formed by a separate component, for example by a flexible duct connecting the reservoir and the applicator. In this case, the cosmetic product may emerge onto the outer surface of the applicator.

25 Advantageously, the cosmetic composition is chosen from a care composition, a cleansing composition, a hygiene composition, an exfoliating composition, a desquamation composition, a thinning composition, a coloring composition, a makeup composition, a makeup removal composition, a whitening composition or a mixture thereof.

30 When the device has a plurality of end pieces, these may contain different cosmetic compositions.

Cosmetic treatment processes

The invention allows various treatment processes.

In one example, the composition is applied without the applicator being driven in motion, and this can make it possible for example to spread the composition over the region to be treated. The applicator is then rotated in order to massage the region to which the composition has been applied.

In another example, the applicator is driven in motion in order to massage the region to be treated, without the composition being dispensed for a first time.

The massaging action may result in local heating on account of the friction of the applicator on the skin for example, and the absence of the composition on the applicator initially may increase the friction and the sensation of heat that results therefrom.

Next, while the applicator is still being driven in motion or, as a variant, while the applicator is at a standstill, the composition may be dispensed and spread over the region previously massaged.

#### Assemblies

A plurality of end pieces may be provided to the user, for example in one and the same packaging, said end pieces comprising:

- reservoirs containing different compositions, and/or
- applicators having different application characteristics.

The invention also relates to an assembly comprising at least one end piece and a device, as defined above.

The invention may be better understood from reading the following detailed description of nonlimiting implementation examples thereof and from examining the appended drawing, in which:

- Figure 1 schematically shows a profile view of an example of an end piece according to the invention in the rest configuration,
- Figure 2 is a schematic and partial longitudinal section through the end piece from Figure 1 after partial use,
- Figure 3 shows a profile view of an example of a device according to the invention,
- Figure 4 shows a top view of an assembly (kit) according to the invention.

The end piece shown in Figures 1 and 2 has:

- a reservoir 1 containing the cosmetic composition P,
- an applicator 2,
- a duct 3 for the composition P to pass between the reservoir 1 and the applicator 2.

5           Figure 1 illustrates the definition of the length L and the largest transverse dimension of the end piece. The length L is the overall length of the end piece. It includes in particular the maximum length of the applicator 2, of the fixing base 50 and of the reservoir 11. The maximum width of the end piece is, in the example in question, the maximum width of the fixing base 50.

10           The reservoir 1 is formed by a bellows 11 that is deformable under the effect of a pressure exerted on the applicator 2. If reference is made more particularly to Figure 1, it is possible to see that the end piece is elongate along a longitudinal axis X and has a reservoir 1 containing the cosmetic composition.

              The passage duct 3 is formed by two through-orifices 31 and 32 (Figure 2).  
15   These orifices perforate the wall 12 which separates the applicator 2 and the reservoir 1.

              The device shown in Figure 3 has a housing 4 for accommodating an end piece such as for example the one illustrated in Figure 1.

              An annular bulge 51 is disposed on the fixing base 50. This bulge 51 may allow the end of the reservoir 1 to be fixed to the body 52 of the device. The fixing base 50  
20   may be fixed to the body 52, in the example in question, by screwing, a magnet, clip-fastening or clamping.

              The body 52 houses means for setting the end piece in motion.

              This movement is for example a rotational movement about a rotation axis X which is fixed relative to the body 52. It forms for example a non-zero angle with the  
25   longitudinal axis Y of the body 52.

              The driving means may comprise an electric motor which is housed in the body 52, is supplied by one or more batteries, and rotates the applicator 2 about the axis X by way of gears.

              In order to dispense a cosmetic composition onto a body surface, the applicator  
30   2 is placed on this surface. A pressure is exerted in the direction of the reservoir 1. The bellows 11 is compressed. The cosmetic composition P is directed towards the orifices 31 and 32. It reaches the surface of the applicator 2 and then the body surface to be treated.

The assembly (kit) shown in Figure 4 has a device 100 and four end pieces 101, 102, 103 and 104. These end pieces are respectively provided with applicators 21, 22, 23 and 24. These applicators each act specifically on the skin. For example:

- the applicator 21 exerts a cleansing action,
- 5 - the applicator 22 exerts an exfoliating action,
- the applicator 23 exerts a massaging action,
- the applicator 24 exerts a smoothing action.

The compositions contained in the end pieces 101, 102 and 103 may be hygiene compositions. The composition contained in the end piece 104 may be a care  
10 composition.

The consumer selects one of the end pieces 101, 102, 103 and 104. He fixes the selected end piece to the device for use.

Needless to say, the invention is not limited to the examples that have just been described. In particular, it is possible to combine together constructional details of  
15 the examples which have just been described within variants that are not illustrated.

In particular, the applicator may have any constitution or form. The dimensions of the end piece may be modified, for example. The movement may also be different.

The expression "comprising a" should be understood as being synonymous  
20 with "comprising at least one", unless specified to the contrary.

CLAIMS

1. End piece for a device for dispensing and applying a cosmetic composition, having:

- 5 - a reservoir (1) containing the cosmetic composition,  
- an applicator (2),  
- a means (3) for the composition to pass between the reservoir (1) and the applicator (2),  
the reservoir (1) having a region (11) that is deformable under the effect of a pressure exerted on the applicator (2).

10

2. End piece according to Claim 1, the region (11) being axially deformable.

3. End piece according to either of the preceding claims, the deformable region (11) comprising a bellows.

15

4. End piece according to any one of the preceding claims, the reservoir (1) being formed in one piece.

5. End piece according to any one of the preceding claims, the product (P) initially taking up from 70 to 100% of the internal volume of the deformable region (11).

20

6. End piece according to any one of the preceding claims, the internal volume of the reservoir (1) being able to retract by a volume of between 10% and 50% of the internal volume of said reservoir (1) in the rest configuration of the deformable region (11).

25

7. End piece according to any one of the preceding claims, the deformable region (11) taking up at least 70% of the overall height of the internal volume of the reservoir (1), said overall height being measured in the rest configuration of the deformable region (11).

30

8. End piece according to any one of the preceding claims, the overall internal volume of the reservoir being between 1 and 100 cm<sup>3</sup> in the rest configuration of the deformable region (11).

9. End piece according to any one of the preceding claims, the ratio  $L/l$  being greater than or equal to 2.

L being the length of the end piece in the rest configuration of the deformable region (11),

5 and

$l$  being the greatest transverse dimension of the end piece in the rest configuration of the deformable region (11).

10 10. End piece according to any one of the preceding claims, the composition being chosen from a care composition, a cleansing composition, a hygiene composition, an exfoliating composition, a desquamation composition, a thinning composition, a coloring composition, a makeup composition, a makeup removal composition, a whitening composition or a mixture thereof.

15 11. Device for dispensing and applying a cosmetic composition contained in an end piece as defined in any one of the preceding claims, said device having a housing (4) for receiving the end piece.

20 12. Device according to Claim 11, having a means for setting the end piece in motion.

13. Device according to either of Claims 11 and 12, wherein the end piece is secured to the housing (4) by pinching, snap-fastening, clip-fastening, screwing, clamping, force-fitting or by magnetization.

25

14. Device according to any one of Claims 11 to 13, comprising electrical supply means.

30 15. Assembly comprising at least one end piece according to any one of Claims 1 to 10 and a device according to any one of Claims 11 to 14.

1/2

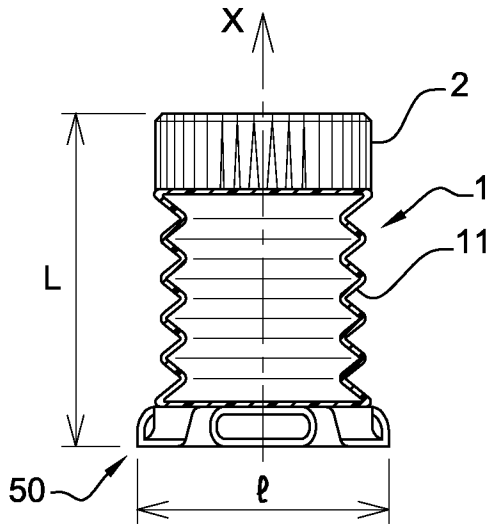

**Fig. 1**

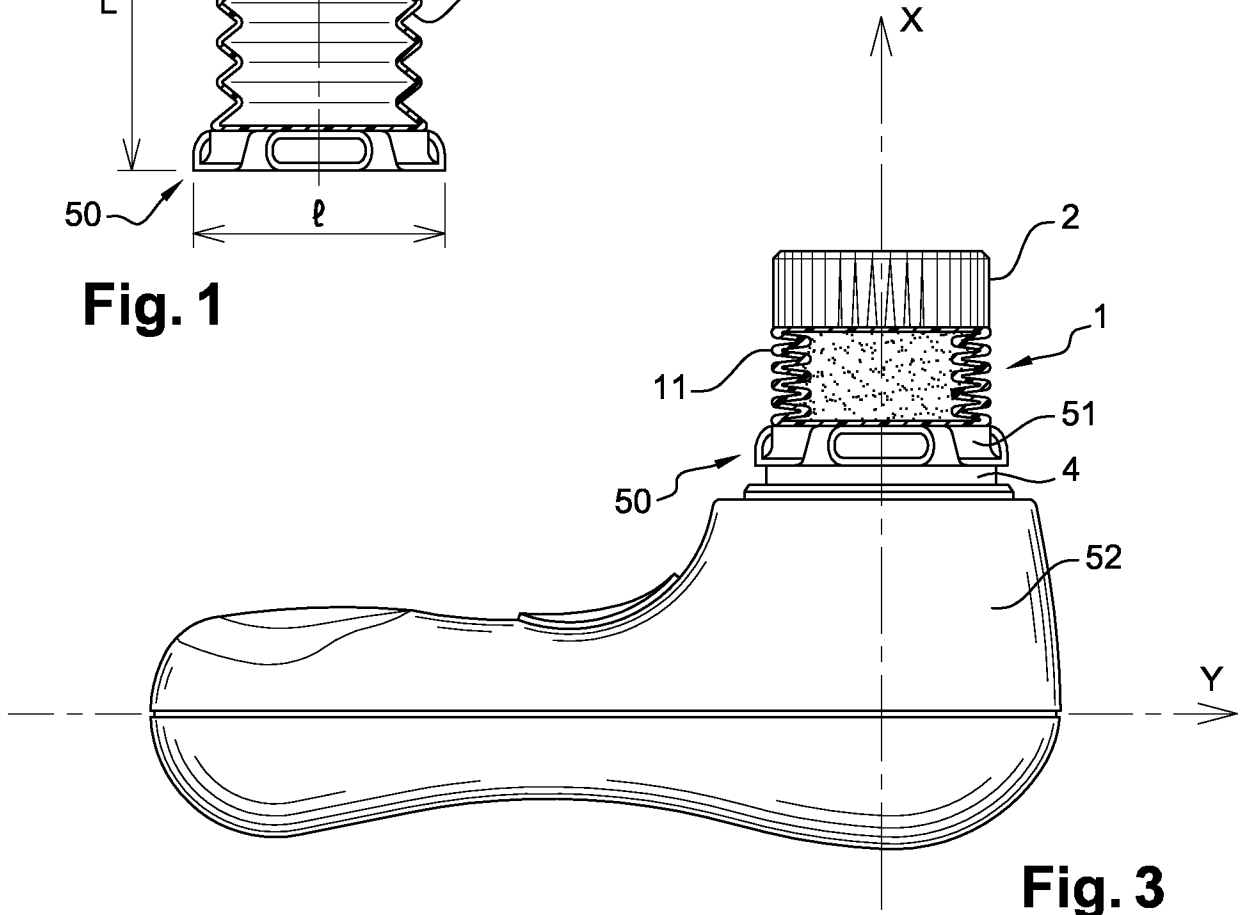

**Fig. 3**

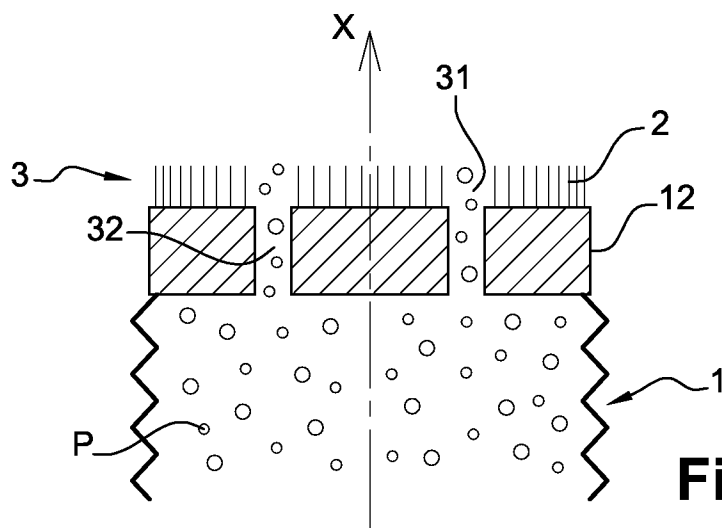

**Fig. 2**

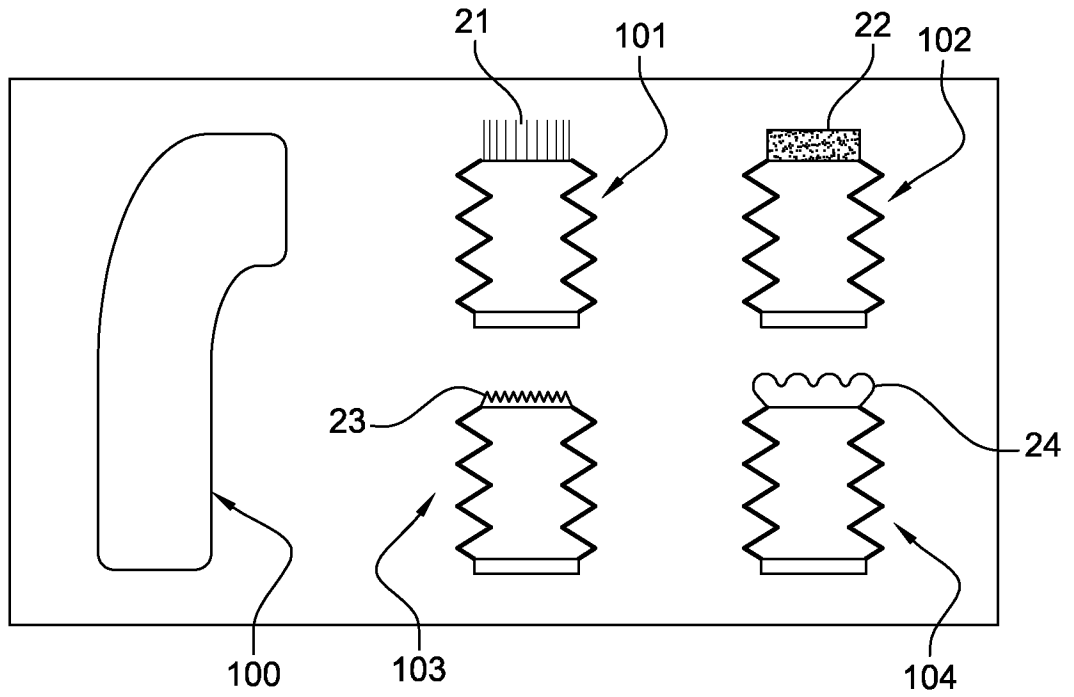

**Fig. 4**

**INTERNATIONAL SEARCH REPORT**

International application No  
PCT/EP2013/077591

**A. CLASSIFICATION OF SUBJECT MATTER**  
 INV. A45D34/04 A46B11/00 A46B13/02 A61H7/00 A61H15/00  
 ADD.

According to International Patent Classification (IPC) or to both national classification and IPC

**B. FIELDS SEARCHED**  
 Minimum documentation searched (classification system followed by classification symbols)  
 A46B A45D A61H

Documentation searched other than minimum documentation to the extent that such documents are included in the fields searched

Electronic data base consulted during the international search (name of data base and, where practicable, search terms used)  
 EPO-Internal, WPI Data

**C. DOCUMENTS CONSIDERED TO BE RELEVANT**

Category*	Citation of document, with indication, where appropriate, of the relevant passages	Relevant to claim No.
X	EP 2 443 958 A1 (TSUIN BADO KOGYO KK [JP]) 25 April 2012 (2012-04-25) paragraph [0033] - paragraph [0035]; figures 1-9 abstract	1,2,4-15
X	US 6 071 029 A (WEINSTOCK JESSE [US]) 6 June 2000 (2000-06-06) column 3 - column 4; figures 1-4	1-12,15
X	US 3 261 367 A (PICKERING JOHN J) 19 July 1966 (1966-07-19) column 2 - column 4; figures 1-8	1-13,15

Further documents are listed in the continuation of Box C.

See patent family annex.

\* Special categories of cited documents :

- "A" document defining the general state of the art which is not considered to be of particular relevance
- "E" earlier application or patent but published on or after the international filing date
- "L" document which may throw doubts on priority claim(s) or which is cited to establish the publication date of another citation or other special reason (as specified)
- "O" document referring to an oral disclosure, use, exhibition or other means
- "P" document published prior to the international filing date but later than the priority date claimed

- "T" later document published after the international filing date or priority date and not in conflict with the application but cited to understand the principle or theory underlying the invention
- "X" document of particular relevance; the claimed invention cannot be considered novel or cannot be considered to involve an inventive step when the document is taken alone
- "Y" document of particular relevance; the claimed invention cannot be considered to involve an inventive step when the document is combined with one or more other such documents, such combination being obvious to a person skilled in the art
- "&" document member of the same patent family

Date of the actual completion of the international search <b>17 April 2014</b>	Date of mailing of the international search report <b>28/04/2014</b>
---	---

Name and mailing address of the ISA/ European Patent Office, P.B. 5818 Patentlaan 2 NL - 2280 HV Rijswijk Tel. (+31-70) 340-2040, Fax: (+31-70) 340-3016	Authorized officer <b>Oliveras, Mariana</b>
--	--

# INTERNATIONAL SEARCH REPORT

Information on patent family members

International application No

PCT/EP2013/077591

Patent document cited in search report	Publication date	Patent family member(s)	Publication date	
EP 2443958	A1	25-04-2012	CN 102573558 A	11-07-2012
			EP 2443958 A1	25-04-2012
			JP 2011000198 A	06-01-2011
			WO 2010147134 A1	23-12-2010
-----				
US 6071029	A	06-06-2000	NONE	
-----				
US 3261367	A	19-07-1966	NONE	
-----				