

B. E. LETANG.
Rotary-Engine.

No. 220,246.

Patented Oct. 7, 1879.

FIG. 1.

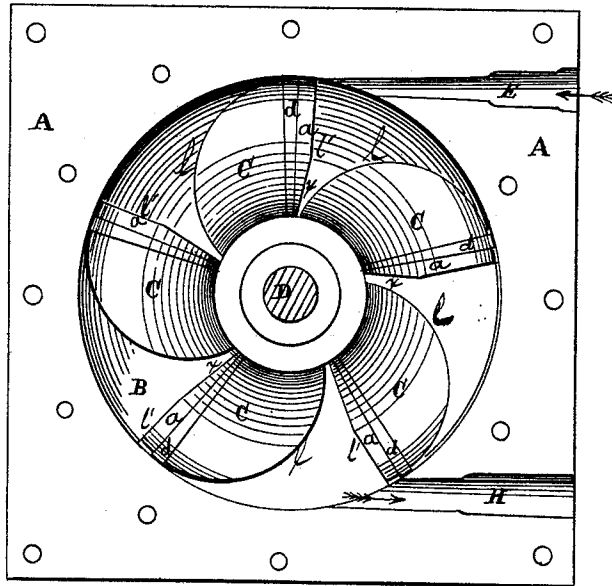
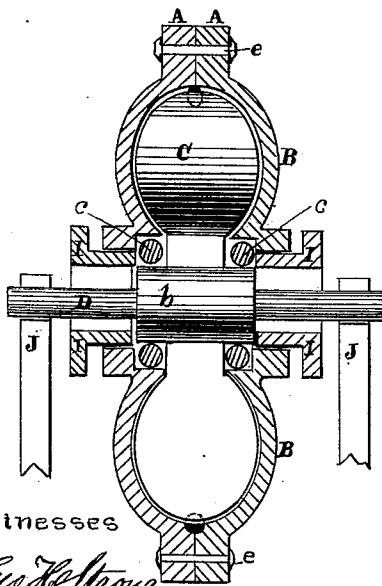

FIG. 2.



Witnesses

Geo. H. Strong
Frank A. Brooks

FIG. 3.

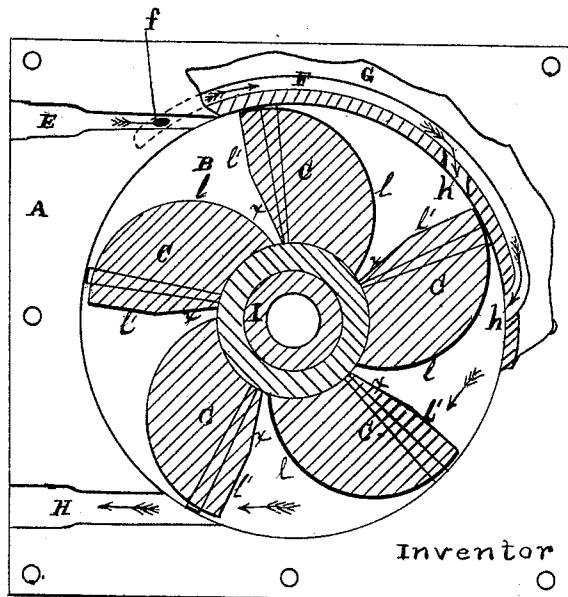

Inventor

Baldamer E. Letang
By Dewey & Co. Atty's

UNITED STATES PATENT OFFICE.

BOLDAMER E. LETANG, OF SAN LEANDRO, CALIFORNIA.

IMPROVEMENT IN ROTARY ENGINES.

Specification forming part of Letters Patent No. 220,246, dated October 7, 1879; application filed April 17, 1879.

To all whom it may concern:

Be it known that I, BOLDAMER E. LETANG, of San Leandro, county of Alameda, and State of California, have invented an Improved Rotary Engine; and I hereby declare the following to be a full, clear, and exact description thereof.

My invention relates to an improved rotary engine; and my improvements consist in attaching to a shaft a series of peculiarly-shaped pistons arranged in a circle on the shaft, so as to rotate it as steam is applied on one side of said pistons.

Figure 1 is a vertical section. Fig. 2 is a transverse section. Fig. 3 is a vertical section, showing the groove F.

The casing in which the pistons rotate is made in two parts, bolted together by means of bolts *e* through the flange A. This casing or cylinder B is made circular in form, and its internal periphery is rounded or grooved, as shown, so as to furnish a circular space for the pistons C to travel in, as hereinafter described.

The neck or stuffing-box projects from each side in toward the center, so that the hub *b* on the shaft D fits closely into the packing-ring *c*, as shown.

On the hub of the axle or shaft D are secured a number of peculiarly-formed pistons, C, which rotate within the grooved or rounded cylinder. These pistons have flat faces *l* in a line radial to the shaft, and are gradually beveled off from the broad end, in a line tangential to the shaft, to a narrow point, as shown at *x*, steam-space being thus left between them. As many of these pistons as are necessary may be used, depending on the size of engine required.

Each piston is provided with a metallic packing, *d*, kept in place by the movable head *a* of the piston, being made somewhat larger in diameter than the main piston, a shoulder being thus formed which retains the packing.

Steam is admitted through the supply-port E, cut in the flange A, so as to allow the steam to enter the cylinder or central chamber on the side which will cause it to strike against the broad heads *a* of the pistons as they revolve with the beveled edges first.

On each side of this main port are the passages *f*, leading to the supplemental steam-

port F. On the offset formed between the outer part of the flanges and the cylinder on each side fits a casing, G, through which the bolts joining the flanges pass. The inner edge of this is cut away, as shown at F, so as to make a steam-port part way round the edge of the cylinder, and connecting with the opening *f*.

Ports or passages *h* are cut through the cylinder to admit steam at proper positions to impinge on the heads of two or more of the pistons beyond the one immediately acted on by steam from the main port.

The discharge-port H is at the lower part of the cylinder, as shown.

The glands I fit into the stuffing-box, and the shaft rests on the journals J, as shown.

In operating this engine the steam admitted to the ports not only meets the full broad face of the piston immediately in front of it, but, by being able to pass through the supplemental ports, also gets behind two or more of the other pistons, so that the full force of the steam is utilized. In this way the steam is acting on three or more of the pistons at one time.

It will be evident that the supplemental steam-port may be made through the edge of the flanges, as well as through the side of them and through the casing, as I have shown it.

This engine is very compact and light, occupying very small space, and requiring less steam than reciprocating engines. As the steam acts on three or more of the pistons at one time, all on one side of the shaft, great power is obtained and direct rotary motion imparted to the shaft.

Having thus described my invention, what I claim as new, and desire to secure by Letters Patent, is—

The piston C, provided with flat faces *l* in a line radial to the shaft, fitting in circular cylinder B, and having enlarged heads *a*, to confine the packing-disk *d*, arranged to rotate on a central shaft by steam-pressure applied to the flat faces, substantially as and for the purpose described.

In witness whereof I have hereunto set my hand.

BOLDAMER E. LETANG.

Witnesses:

CHAS. G. YALE,
FRANK A. BROOKS.