

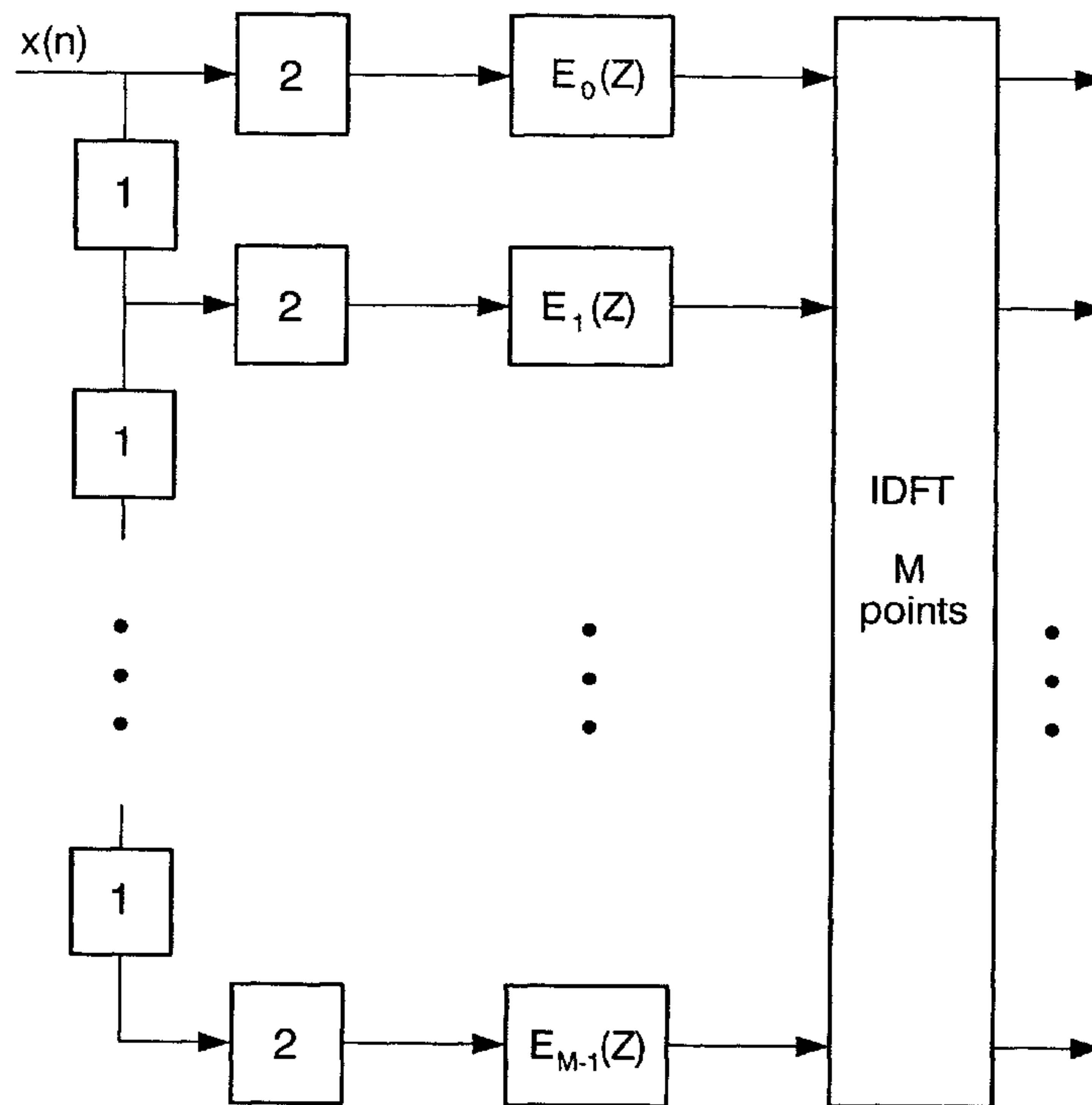

(86) Date de dépôt PCT/PCT Filing Date: 2004/01/08
 (87) Date publication PCT/PCT Publication Date: 2004/07/29
 (85) Entrée phase nationale/National Entry: 2005/07/08
 (86) N° demande PCT/PCT Application No.: ES 2004/000003
 (87) N° publication PCT/PCT Publication No.: 2004/064278
 (30) Priorité/Priority: 2003/01/10 (P200300052) ES

(51) Cl.Int.⁷/Int.Cl.⁷ H04J 11/00, H04L 7/00
 (71) Demandeur/Applicant:
 DISEÑO DE SISTEMAS EN SILICIO, S.A., ES
 (72) Inventeurs/Inventors:
 BLASCO CLARET, JORGE VICENTE, ES;
 RIVEIRO INSUA, JUAN CARLOS, ES;
 IRANZO MOLINERO, SALVADOR, ES
 (74) Agent: MARKS & CLERK

(54) Titre : PROCEDE DE SYNCHRONISATION DANS LE DOMAINE DU TEMPS ET DE LA FREQUENCE DE MULTIPLES EQUIPEMENTS DANS UN SYSTEME DE TRANSMISSION A MODULATION OFDM
 (54) Title: METHOD FOR THE TIME- AND FREQUENCY-DOMAIN SYNCHRONISATION OF MULTIPLE DEVICES IN A TRANSMISSION SYSTEM WITH OFDM MODULATION



(57) **Abrégé/Abstract:**

The invention relates to a method for the time- and frequency-domain synchronisation of multiple devices in a transmission system with OFDM modulation. The inventive method can be used for the synchronisation of multiple users, by employing the improvement to the estimate of the OFDM symbol start and the improvement to the estimate of the frequency error in noisy environments or with frequency-selective channels. The invention is characterised by the decomposition of the signals received $x(n)$, which contain the synchronism sequences and data, into frequency bands (M) and by the application of synchronisation algorithms to each of said bands.

ABSTRACT

5 Allows synchronisation of multiple users by means of
improving the estimation of the start of the OFDM symbols
and improving the estimate of frequency error in noisy
environments or in frequency selective channels. It is
characterized by the decomposition of the received signals
10 $x(n)$, that contain data and synchronization sequences, in
frequency bands (M) and the application of synchronisation
algorithms in one of said bands.

**PROCESS OF SYNCHRONIZATION IN THE TIME AND FREQUENCY DOMAIN
OF MULTIPLE EQUIPMENTS IN A TRANSMISSION SYSTEM WITH OFDM
MODULATION**

OBJECT OF THE INVENTION

5 The present invention, as described herein refers to a
process of synchronization in the time and frequency domain
for multiple equipments in a transmission system using OFDM
(orthogonal frequency division multiplexing) modulation.
The objective of this process is to improve the estimation
10 of the start of the OFDM symbols and the estimation of
frequency error in the oscillators in various situations
such as in channels with narrow band noise, frequency
selective channels or channels in which noise power varies
with frequency. The application of this process to
15 synchronisation also as well as facilitating simultaneous
estimation of frequency error in the analog traslation and
frequency error in the system sample allows said
estimations to be carried out in situations where the
classic synchronisation processes do not achieve results.

20 Furthermore, in cases where it is possible to carry
out various estimations of these factors, the results, in
the form of average or weighted average can be combined to
achieve more accurate estimations with a smaller deviation
from the real value that one wants to estimate.

25 **BACKGROUND TO THE INVENTION**

It is necessary to carry out a synchronisation process in
the majority of telecommunication systems so as to
adequately obtain the information transmitted from the
received signals to the channel. One or more types of
30 synchronization are required depending on how the
transmission is carried out and the modulation used. In
general, to transmit using OFDM modulation it is necessary
to carry out synchronisation in time which consists of
determining the start of the OFDM symbols in reception, and
35 synchronization in frequency, so that frequency of the

oscillators used for the sample or for the analog traslation of transmitted and received signal is sufficiently close.

5 Many methods of synchronisation of OFDM signals are known in the state of the art but none of these are secure enough to avoid false indications of synchronisation in point to multipoint systems in which the electricity network is the transmission means used.

10 It is well known that use of the electricity network as a transmission means is problematic for synchronisation since the connection-disconnection of various apparatus on the network produces tension peaks and impedance variation on the line causing channel response to vary in time. Impulsive noises, which are very usual in the electricity
15 network affect synchronisation, in large part because by definition these are occasional noises that affect a small number of samples and therefore can impede adequate detection of the synchronisation sequences if they coincide in time with said sequences. Band separation as proposed
20 in this patent, reduces the consequences of these noises so that it is possible to apply known synchronization methods, which due to the improvement proposed will offer optimum results in noisy environments such as the electricity network.

25 Among the synchronisation methods in the state of the art those that particularly stand out are described in US Patent No 5732113 which describes a process of time synchronisation that uses a single synchronisation symbol with two equal half symbols, and that described in Spanish
30 patent submission 200.101.121 which refers to a "process for the synchronisation in the down stream of various uses in a point to multipoint transmission system with OFDM modulation", and which describes the transmission of two identical synchronisation symbols. The present invention
35 improves synchronisation in the time and frequency domains

due to synchronisation in various bands and achieves results with less variance and better adjusted to the real value than that which can be achieved by applying either of the previously mentioned process. Furthermore, the application of the method proposed allows synchronisation to be carried out in many cases where noise on the line and channel characteristics would prevent the achievement of any result when using known synchronisation methods.

On the other hand, it is important to indicate that the filter banks such as those described in the book "Multirate Systems and Filters Banks", by P.P. Vaidyanathan, published by Prentice Hall in 1993, are known but that these filters have not been used for the division of synchronisation sequences received for independent detection in frequency bands such as described in this invention and which achieves the considerable improvement over the state of the art as described above.

DESCRIPTION OF THE INVENTION

To achieve the objectives and avoid the inconveniencies described in previous paragraphs, this invention consists of a process for synchronisation in the time and frequency domain for multiple equipments in a transmission system with OFDM modulation.

This process is applicable to two-way communication applicable to two-way communication over the electricity network between different equipments connected to the same electricity network so as to provide an estimation of the start of the OFDM symbols in reception and the frequency error of the local oscillators in the equipments, and comprises the generation of synchronisation sequences that are transmitted over the electricity network. These synchronisation sequences are sent over the same channel used for the sending of data, said channel characterised by a connection between one equipment and all the other equipments. The process is characterized because it

comprises the decomposition of the received signals made up of the synchronisation sequences and data in various frequency bands or ranges. Thereafter, the synchronisation sequences of each one of the frequency bands is detected by
5 applying a synchronisation algorithm in time that allows the start of the OFDM symbol and frequency error in the local oscillators in each frequency band to be estimated, instead of the complete received signal which is the conventional method.

10 It is thanks to these characteristics that the process allows improvement in the estimation of the start of the OFDM symbols and in the estimation of frequency error in the oscillators in the equipments in cases where narrow band noises are present in the channel, that is, ingress
15 noise. In case of transmission over a frequency selective channel it improves estimation of the start of the OFDM symbols and it improves frequency error in the case that the noise power added to the channel by the signal varies with frequency, that is, in case the channel includes
20 coloured noise. Another of the advantages of this process is that it permits estimation of sample frequency error, that increases linearly with frequency and which cannot be estimated conventionally with the complete signal, and it improves estimation of frequency error in analog traslation
25 with respect to the use of the complete received signal for the estimation of same. It also allows simultaneous estimation of frequency error in analog traslation and carries out the estimation of the start of the OFDM symbols as well as calculating frequency error in the sample when
30 detected in two or more frequency bands or ranges including in cases where use of the complete signal does not produce a result. Finally, the process in this invention facilitates improving the results of the estimation of the start of the OFDM signal and the frequency error in case
35 detection of the synchronisation sequence is achieved in

more than one frequency band by means of combining the estimation obtained in each frequency and, by average or weighted average linear regression.

In the process in this invention break down of the received signal into frequency bands or ranges is carried out by applying a band pass filter centred in each one of the frequency bands, a frequency traslation in the filtered signals to work with each band in base band, and optionally, an decimator to simplify the complexity of the electronics necessary to detect the synchronisation sequence.

Another way of carrying out this break down is to filter the synchronisation sequences simultaneously by means of uniform and decimated DFT (Discreet Fourier Transform) filters with the complexity of a prototype band pass filter, and a Discreet Fourier Transform (DFT).

In the same way, the breakdown or the synchronisation sequences may also be carried out directly by means of a Discreet Fourier Transform (DFT) circuit.

In the process described in this invention, detection of the synchronisation sequences takes place in each one of the frequency bands or ranges by means of maximizing the maximum likelihood known conventionally so that estimation of the start of the OFDM symbols is carried out from the calculation of the maximum time correlation of the samples in each band, and this maximum becomes the mid point in the flat zone for the correlation peak, whose size in number of samples is equal to the number of samples of the cyclic prefix without inter-symbol interference (ISI), and thereafter the angle of this correlation in the moment determined as maximum correlation is calculated in each one of the frequency bands so as to achieve an estimate of frequency error and adjust the oscillators to a common reference.

The correlation maximum is calculated by detecting the

correlation peaks that surpass a power threshold in each one of the frequency bands or ranges in the received signal, and because the value of this threshold is fixed to minimize the probability of producing false alarms, and
 5 the correlation is calculated by means of the following algorithm:

$$P_i(d) = \sum_{m=0}^{L-1} (r_{i,d-m} r_{i,d-m-L}^*)$$

10 and the power is calculated by means of the following algorithm:

$$R_i(d) = \frac{1}{2} \sum_{m=0}^{2L-1} |r_{i,d-m}|^2$$

15 where $r_{i,d}$ is the signal corresponding to the frequency corresponding to the i -esima in the moment d , L is the number of samples in the half symbol, $P_i(d)$ is the correlation in the band i -esima in the moment d and $R_i(d)$ power in the band i -esima in the moment d .

20 The calculation of correlation and power is undertaken iteratively, storing the samples and preferably the partial products to calculate the correlation and the power by means of the following algorithms:

$$P_i(d) = P_i(d-1) + r_{i,d} r_{i,d-L}^* - r_{i,d-L} r_{i,d-2L}^*$$

25

$$R_i(d) = R_i(d-1) + \frac{1}{2} |r_{i,d}|^2 - \frac{1}{2} |r_{i,d-2L}|^2$$

where $P_i(d)$ is the correlation in the frequency band i -esima in the moment d , $R_i(d)$ power in the i -esima band and in the moment d , and $r_{i,x}$ the signal corresponding to the i -esima band in the moment x .

30 The moment of detection of the synchronisation

sequences is taken to be the mid point of the zone that exceeds 90% of the maximum correlation while delaying an adequate number of samples to reduce interference between symbols to a minimum, and the number of samples is
5 adjustable.

On the other hand, because the real part of the correlation dominates the imaginary part it is possible to use only the real part of the correlation to simplify the calculation of the correlation in each frequency band or
10 range if the frequency error is less than a certain threshold.

To improve the results of the estimation of the start of the OFDM symbols in each frequency band one can combine these results as averages or weighted averages so that the
15 final estimate will be more reliable and with less variance than that obtained using the complete received signal without separation in ranges.

Separating frequency bands improves the calculation of the frequency error in analog traslation by reducing
20 variance when the averages or weighted averages of the error values calculated in each of the frequency bands is used.

Furthermore, separating the frequency bands permits estimation of error in the sample frequency by means of
25 linear regression of the values of the errors obtained in each band and said error value cannot be estimated conventionally using the full received signal since the error in sample frequency increases with frequency.

Finally, and thanks to the separation into bands, the
30 error in analog frequency traslation and the error in sample frequency can be estimated simultaneously.

On the other hand, the process in this invention may also be used when coexistence symbols are transmitted, these are detected in reception by means of band separation
35 and detected in each one of these bands, with the objective

of allowing the system to recognize if another has transmitted a certain sequence in the channel or not.

The following drawings are provided to facilitate a better understanding of the present invention and while forming an integral part of the detailed description and the claims, they offer an illustrative but not limited representation of the principles of this invention.

BRIEF DESCRIPTION OF THE DRAWINGS

Figure 1.- Represents an example spectral density of signal power and noise in reception in a specific scenario.

Figure 2.- Graphically represents one of the means of carrying out division into frequency bands or ranges using uniform and decimated discrete Fourier transform (DFT) filters.

Figure 3.- Graphically represents a typical correlation scenario and the power multiplied by a threshold starting from the samples obtained in reception.

Figure 4.- Demonstrates the comportment of the error in the sample frequency and the error in the analog translation frequency.

DESCRIPTION OF AN EMBODIMENT OF THE INVENTION

This section provides a description of an example of one embodiment of the invention, referencing the numbering used in the drawings.

All communication systems or at least a part of the communication system such as the synchronization block, require a minimum signal to noise ratio (SNR) in order to be able to function, that is, it is necessary that the received signal has a certain value relative to the noise value on the line so that the system can carry out communication. Minimum SNR cannot reach all the band width used by the system in communication systems with a frequency selective channel, or in systems where noise is dependent on frequency, or in both, due to existing channel attenuation or to the noise level, however it can reach

some frequency ranges within the total band width. The process described in this invention takes advantage of this circumstance to calculate estimates and synchronisation in such scenarios.

5 Figure 1 shows spectral density of signal power and noise at the receptor entrance in a certain situation. In this case, average SNR over the total band is 0dB, which is not enough for communication, but it can be seen that in certain frequency ranges the power density of the signal is
10 higher than the noise and therefore in these ranges communication will be possible. Due to the behaviour of the channel in such situations classic processes either cannot achieve synchronisation, or they only achieve it with very poor quality. This type of channel is very common in
15 systems that use the electricity network as the transmission medium. The process described in this invention undertakes division into various frequency ranges (by means of filtering in reception) and works on each one these signal separately. In the majority of situations,
20 synchronisation is necessary to transmit a specific signal in each one of the frequency bands, and being able to synchronize in any of the bands improves the results. It is not enough to transmit an OFDM signal due to a specific characteristic of this type of modulation whereby
25 multiple carriers once separated can regroup in bands. To divide the signal into bands a band pass filter centred in each of the frequency bands can be applied. Furthermore, the signal must be demodulated to take it to base band and decimated because if this is not done the frequency in each
30 band will be the same as that in the original signal and total complexity will be multiplied by the number of bands. All these operations can be carried out simultaneously and efficiently using uniform and decimated DTF (discreet Fourier transform) filter banks, which is a well know
35 process in the state of the art. In this case, the filter

banks are as complex as a prototype band pass filter (which as mentioned previously is located in each frequency band) and it is used with a DFT. This structure can be seen in Figure 2 where the filters $E_i(z)$ correspond to the poly phase decomposition of the prototype filter where $i=0, 1..M-1$ where M is the number of bands in which the received signal $x(n)$ is decomposed, 1 is a sample delay of (z^{-1}) and 2 is a decimator for M . Decomposition of the entry signal in M frequency bands occurs at the exit to the inverse Fourier transform (IDFT)³ and each of the frequency bands has a sample frequency M times less than that of the entry signal. M is also the number of points in the IDFT. From this point in the system each of the M signals is treated independently and the estimations are carried out for each one of these bands separately. The complexity is similar to that obtained on carrying the estimations for the original signal since we have M signals but the master frequency for each one has been divided by M . Furthermore, some of the bands (sub-bands) may be eliminated if they do not contain information and therefore the complexity is further reduced.

The specifications for the prototype filter depend on the particular application for which the process described in this invention will be used. Some examples of such applications include estimation of signal parameters, the detection of coexistence signals or the detection of synchronism signals.

Another of these applications is synchronisation in OFDM systems. The majority of synchronisation methods for OFDM signals use the signal in time to carry out this function and therefore they fail in situations such as that presented in Figure 1.

It is principally in such cases that use of the structure presented in Figure 2 can improve the synchronisation. In each of the frequency bands into which

the signal is divided one may apply any of the methods described in the state of the art and correct synchronization in one band is sufficient to begin the demodulation process in reception, depending on the type of modulation used.

When SNR is high enough so that various band synchronise then we have various estimations of the start of the symbol and frequency error simultaneously and therefore techniques such as combining results to improve the final estimation can be applied.

The result is a method of synchronisation with diversity in frequency, highly resistant to narrow band noises, channel selectivity and power noise dependent on frequency and which can function in typical channels including in those with SNR less than -10dB over the whole band. The only requirement needed is that SNR in one of the frequency bands or ranges are sufficient to detect the synchronisation signal used in this band.

For example, to obtain optimum results, this process can be applied along with the synchronisation method described in Spanish patent submission 200.101.121 concerning a "Process for downstream synchronisation of multiple users in a point to multipoint transmission system with OFDM modulation".

In this case, the signal to be transmitted is the same as in said patent, that is to say, two identical synchronisation symbols, due to the fact that this property is maintained when the signal is decomposed in the frequency bands. A structure such as that shown in Figure 2 is placed in the receptor and thereafter the power and correlation metrics are calculated as in the patent mentioned above except that in this present case, the limits of all the sums are divided by M where M is the decimated value of the entry signal, or to put it another way, the number of bands.

Thanks to the separation of frequency into bands it is possible to carry out various estimations using only one synchronisation symbol and it is possible to achieve good synchronisation results even when using only one
5 synchronisation symbol as a synchronisation sequence.

In this case, the synchronisation sequence is composed of only one synchronisation symbol divided into two equal halves. The information transmitted in the carriers used in the synchronisation symbols may be in fixed or psuedo-
10 random sequence. The odd and even carriers in the OFDM symbols are set at zero so as to have the symmetry required in the synchronisation symbols.

The properties of the synchronisation symbol, and more specifically its symmetry, is maintained when the bands are separated in reception and this allows us to have multiple
15 synchronisation results which facilitate improving their precision.

Any other type of synchronisation sequence (in relation to the number of symbols sent) and the method of
20 detection may use the same method as described previously, only if the properties of the synchronisation symbol are maintained when band separation is carried out.

Therefore it is possible to use the following estimations in each one of the intervals as mentioned in US
25 patent 5732113 "Timing and frequency synchronisation of OFDM signals" and combine these to obtain estimations with reduced variance using only one symbol as a synchronisation sequence:

$$P_i(d) = \sum_{m=0}^{L-1} (r_{i,d-m} r_{i,d-m-L}^*)$$

30

$$R_i(d) = \frac{1}{2} \sum_{m=0}^{2L-1} |r_{i,d-m}|^2$$

Where $r_{i,d}$ is the exit in the i -esima branch of the filter band in the moment d , L is the number of samples in the half symbol divided by M , M is the number of bands that the signal is divided into, $P_i(d)$ is the correlation of the i -esima branch in the moment d and $R_i(d)$ power in i -esima branch in the moment d . In a similar way one can continue to apply the formulae iteratively.

$$10 \quad P_i(d) = P_i(d-1) + r_{i,d} r_{i,d-L}^* - r_{i,d-L} r_{i,d-2L}^*$$

$$R_i(d) = R_i(d-1) + \frac{1}{2} |r_{i,d}|^2 - \frac{1}{2} |r_{i,d-2L}|^2$$

Once correlation and power have been calculated, synchronisation is detected as in the patent previously mentioned, the difference being that now we have various bands that are susceptible to synchronisation. Figure 2 shows a typical case where synchronization is produced when the calculated power exceeds the correlation threshold. In the case where various bands synchronize the most appropriate estimator to use is the average of the estimations of the start of the symbol. It must be stated that each one of the estimations separately has a resolution M times less than the global estimate due to the decimator but variance in the final estimate is better than in previous methods when using the average.

25 In the same way, sample frequency error may be calculated from the correlation angle in the optimum moment in the window, substituting f_i for central frequency in the band (sub-band).

$$\Delta f_s / f_s = - \frac{\angle P_i(d_{opt})}{2\pi f_i K(N/2)}$$

30 Where $\angle(\cdot)$ is the angle parameter, f_i central frequency in the i -esima band, K the interpolation order or

decimator and N the number of samples in the OFDM symbol.

Depending on the type of error introduced by the system in this invention one estimates either, frequency error on traslation to the analog band, sample frequency error or both. The results obtained in each band are combined in one way or the other depending on the type of error that we need to estimate.

In case the system only has frequency error on traslation to the analog band, the average of the estimates in the different bands can be used as the estimation, as is shown in Figure 4 (error type 1) since the error is the same in all bands. However, if what is needed is to calculate sample frequency error (error type 2), this process can not be immediately used since the value is not the same in all bands, rather, starting from the origin of the coordinates it increases with frequency as shown in Figure 4. A linear regression of the co-relation angles in each one of the bands (by means of minimum squares or other known mathematical methods) is carried out to estimate the slope of this straight line and obtain a better estimation, and this can be carried out independently of the bands that are being synchronized. The estimation presented in the Spanish patent submission mentioned previously was reduced in selective frequency channels, due to the fact that it measured frequency error in the bands that suffered less attenuation. With this new method this reduction disappears since the error in each band is independently measured, thereby improving the estimation of the error. The following formulae may be used to estimate this error:

$$m = \sum_i \frac{f_i^* \angle P_i(D_{iopt})}{f_i^2}$$

$$\Delta f_s / f_s = \frac{-m}{2\pi KI(N/2)}$$

Where m is the result of linear regression of the estimates of the different band and $\Delta f_s / f_s$ sample frequency error.

Another advantage of the process in this invention is that it offers the possibility to simultaneously calculate error in sample frequency and error in traslation to the analog band (error type 3), by carrying out linear regression of the errors measured in each band to calcualte the slope (sample frequency error) and the cross over with the vertical axis (analog traslation frequency error) as can be seen in figure 4. Mathematically these values can be calcualted by:

$$m = \frac{n \sum_i f_i^* \angle P_i(d_{iopt}) - \sum_i f_i^* \sum_i \angle P_i(d_{iopt})}{n \sum_i f_i^2 - \left[\sum_i f_i \right]^2}$$

20

$$b = \frac{\sum_i \angle P_i(d_{iopt}) - m \sum_i f_i}{n}$$

25

$$\Delta f_{IQ} = \frac{-b}{2\pi(T_s/2)}$$

Where n is the number of estimators used linear regression, T_s is the time of the symbol with cyclical prefix and Δf_{IQ} is the error in frequency traslation in the

analog band. Sample frequency error is obtained from m as in the case where only sample frequency error occurs.

The process in this invention can also be used for
5 coexistence signalling, that is the detection of signals
used to implement a protocol for coexistence of various
technologies over one transmission medium. In these
protocols special signals that all systems must necessarily
be capable of transmitting and receiving are used in order
10 to implement an equitable medium access control, and must
be detected even in conditions of very low SNR. In
transmission media such as the electricity network or radio
there is the added problem that these systems can transmit
simultaneously if attenuation between them is sufficient to
15 have the signals of one arrive at the other below the noise
level, thereby making them undetectable to each other.
Coexistence signals serve to determine if two or more nodes
(equipment that may belong to one or more different
communication systems) may transmit simultaneously,
20 depending on whether the signal of one node is received by
the other with more or less power than noise for each one
of the frequencies used in the communication.

Using current known methods it is very difficult to
carry out this detection in scenarios such as that
25 presented in Figure 1 and therefore it is convenient to use
the process described in the present invention. In this
case, the best option is to transmit various signals in
different frequencies (the number of frequencies depending
on frequency selectivity in the channel), which are
30 independently detected in reception. Detection of one of
these frequencies is sufficient to determine that one node
is transmitting the coexistence signal. To separate the
different signals the structure shown in Figure 2 is used
in reception.

35 If the modulation used in one of the systems that must

coexist is OFDM it is enough that some of the carriers have sufficient SNR for the demodulation of these carriers to be correct thanks to the good behaviour of this type of modulation in these type of frequency selective channels.

5 It is also possible to carry out detection even when SNR is average or negative, if the correct value can be obtained in one of the ranges in which the received signal has been divided. If a coexistence signal that occupies full band width is used to implement coexistence it may give rise to
10 the fact that this signal will not be detected by a node that uses OFDM modulation and two nodes may simultaneously occupy the channel causing interference, since the signal of one will not be lower than the noise level detected in reception in all frequencies in the second node. According
15 to what is described herein, the process in this invention solves this problem.

20

25

30

35

CLAIMS

1. A PROCESS OF SYNCHRONIZATION IN THE TIME AND FREQUENCY DOMAIN OF MULTIPLE EQUIPMENTS IN A TRANSMISSION SYSTEM WITH OFDM MODULATION, applicable to two-way communication over
5 the electricity network between different equipments connected to the same electricity network so as to provide an estimation of the start of the OFDM symbols in reception and the frequency error of the local oscillators in the equipments, including the generation of synchronisation
10 sequences that are transmitted over the electricity network and the sending of these synchronisation sequences over the same channel used for the sending of data, where said channel is determined by a connection between one equipment and all the other equipments, characterized because it
15 comprises:

- breaking down the received signals that contain the data and synchronisation sequences in various frequency bands or ranges;
- detecting the synchronisation sequences in each
20 frequency range or band in reception by means of applying a synchronisation algorithm in time to estimate in each frequency band, the start of the OFDM symbols and the frequency error of the local oscillators on the basis of this algorithm;
- 25 - combining the estimations obtained in each frequency band.

2. A PROCESS OF SYNCHRONIZATION IN THE TIME AND FREQUENCY DOMAIN OF MULTIPLE EQUIPMENTS IN A TRANSMISSION SYSTEM WITH OFDM MODULATION, according to Claim 1 characterized because
30 the break down of the received signal into frequency bands or ranges is carried out using a band pass filter centred in each one of the frequency bands, frequency traslation of each of the filtered signal so as to work in base band with each band and selectively, a decimator to simplify the
35 complexity of the electronics necessary to detect the

synchronisation sequence.

3. A PROCESS OF SYNCHRONIZATION IN THE TIME AND FREQUENCY DOMAIN OF MULTIPLE EQUIPMENTS IN A TRANSMISSION SYSTEM WITH OFDM MODULATION, according to Claim 1, characterized because the break down of the received signal is carried out simultaneously by means of a Decimated uniform DFT filter bank, with the complexity of a prototype band pass filter, and a Discreet Fourier Transform (DFT) circuit.

4. A PROCESS OF SYNCHRONIZATION IN THE TIME AND FREQUENCY DOMAIN OF MULTIPLE EQUIPMENTS IN A TRANSMISSION SYSTEM WITH OFDM MODULATION, according to Claim 1, characterized because the breakdown of the received signal is carried out be means of a discreet Fourier transform (DFT) circuit.

5. A PROCESS OF SYNCHRONIZATION IN THE TIME AND FREQUENCY DOMAIN OF MULTIPLE EQUIPMENTS IN A TRANSMISSION SYSTEM WITH OFDM MODULATION, according to Claim 1, characterized because the detection of the synchronisation sequences is carried out in each of the frequency bands or ranges using the maximization of the maximum likelihood criteria to estimate the start of the OFDM symbols, beginning with the calculation of the maximum time correlation of the samples in each band, and this maximum becomes the mid point in the flat zone for the correlation peak, whose size in number of samples is equal to the number of samples of the cyclic prefix without inter-symbol interference (ISI) and thereafter calculating the angle of this correlation in the moment determined as maximum correlation in each one of the frequency bands so as to estimate the frequency error and adjust the oscillators to a common reference.

6. A PROCESS OF SYNCHRONIZATION IN THE TIME AND FREQUENCY DOMAIN OF MULTIPLE EQUIPMENTS IN A TRANSMISSION SYSTEM WITH OFDM MODULATION, according to Claim 5, characterized because the correlation maximum is calculated by detecting the correlation peaks that surpass a power

threshold in each one of the frequency bands or ranges in the received signal, and because the value of this threshold is fixed to minimize the probability of producing false alarms, and the correlation is calculated by means of
5 the following algorithm:

$$P_i(d) = \sum_{m=0}^{L-1} (r_{i,d-m} r_{i,d-m-L}^*)$$

and the power is calculated by:

10

$$R_i(d) = \frac{1}{2} \sum_{m=0}^{2L-1} |r_{i,d-m}|^2$$

where $r_{i,d}$ is the signal corresponding to the frequency corresponding to the i -esima in the moment d , L is the
15 number of samples in the half symbol, $P_i(d)$ is the correlation in the band i -esima in the moment d and $R_i(d)$ power in the band i -esima in the moment d .

**7.A PROCESS OF SYNCHRONIZATION IN THE TIME AND FREQUENCY DOMAIN OF MULTIPLE EQUIPMENTS IN A TRANSMISSION
20 SYSTEM WITH OFDM MODULATION,** according to Claim 6, characterised because the calculation of correlation and power is undertaken iteratively, storing the samples and preferably the partial products to calculate the correlation and the power by means of the following
25 formula:

$$P_i(d) = P_i(d-1) + r_{i,d} r_{i,d-L}^* - r_{i,d-L} r_{i,d-2L}^*$$

$$R_i(d) = R_i(d-1) + \frac{1}{2} |r_{i,d}|^2 - \frac{1}{2} |r_{i,d-2L}|^2$$

where $P_i(d)$ is the correlation in the frequency band i -esima in the moment d , $R_i(d)$ power in the i -esima band and
30 in the moment d , and $r_{i,x}$ the signal corresponding to the i -

esima band in the moment x .

8. A PROCESS OF SYNCHRONIZATION IN THE TIME AND FREQUENCY DOMAIN OF MULTIPLE EQUIPMENTS IN A TRANSMISSION SYSTEM WITH OFDM MODULATION, according to Claim 6, characterized because the moment of detection of the synchronisation sequences is taken to be the mid point of the zone that exceeds 90% of the maximum correlation while delaying an adequate number of samples to reduce interference between symbols to a minimum, and the number of samples is adjustable.

9. A PROCESS OF SYNCHRONIZATION IN THE TIME AND FREQUENCY DOMAIN OF MULTIPLE EQUIPMENTS IN A TRANSMISSION SYSTEM WITH OFDM MODULATION, according to Claim 6, characterized because when frequency error is less than the threshold previously fixed only the real part of the correlation in each band is used.

10. A PROCESS OF SYNCHRONIZATION IN THE TIME AND FREQUENCY DOMAIN OF MULTIPLE EQUIPMENTS IN A TRANSMISSION SYSTEM WITH OFDM MODULATION, according to Claim 1, characterised because the results of the estimation of the start of the OFDM symbols in each frequency band are combined by means of averages or weighted averages to obtain an estimate with less variance.

11. A PROCESS OF SYNCHRONIZATION IN THE TIME AND FREQUENCY DOMAIN OF MULTIPLE EQUIPMENTS IN A TRANSMISSION SYSTEM WITH OFDM MODULATION, according to Claim 1 characterised because the average of the errors in analog frequency traslation are carried out to reduce the variance in the error values calculated in each one of the frequency bands.

12. A PROCESS OF SYNCHRONIZATION IN THE TIME AND FREQUENCY DOMAIN OF MULTIPLE EQUIPMENTS IN A TRANSMISSION SYSTEM WITH OFDM MODULATION, according to Claim 1 characterised because sample frequency error is estimated by means of linear regression of the values of the errors obtained in each band following the application of the separation of the

bands in frequency.

13. A PROCESS OF SYNCHRONIZATION IN THE TIME AND FREQUENCY DOMAIN OF MULTIPLE EQUIPMENTS IN A TRANSMISSION SYSTEM WITH OFDM MODULATION, according to Claim 1 characterised because
5 by separating the bands in frequency, the error in analog frequency traslation and the error in sample frequency are estimated simultaneously.

14. A PROCESS OF SYNCHRONIZATION IN THE TIME AND FREQUENCY DOMAIN OF MULTIPLE EQUIPMENTS IN A TRANSMISSION SYSTEM WITH
10 OFDM MODULATION, according to Claim 1 characterised because coexistence symbols that are detected in reception by means of band separation are transmitted and detected in each one of these bands allowing the system to recognize if another has transmitted a certain sequence in the channel or not.

15

20

25

30

35

1/4

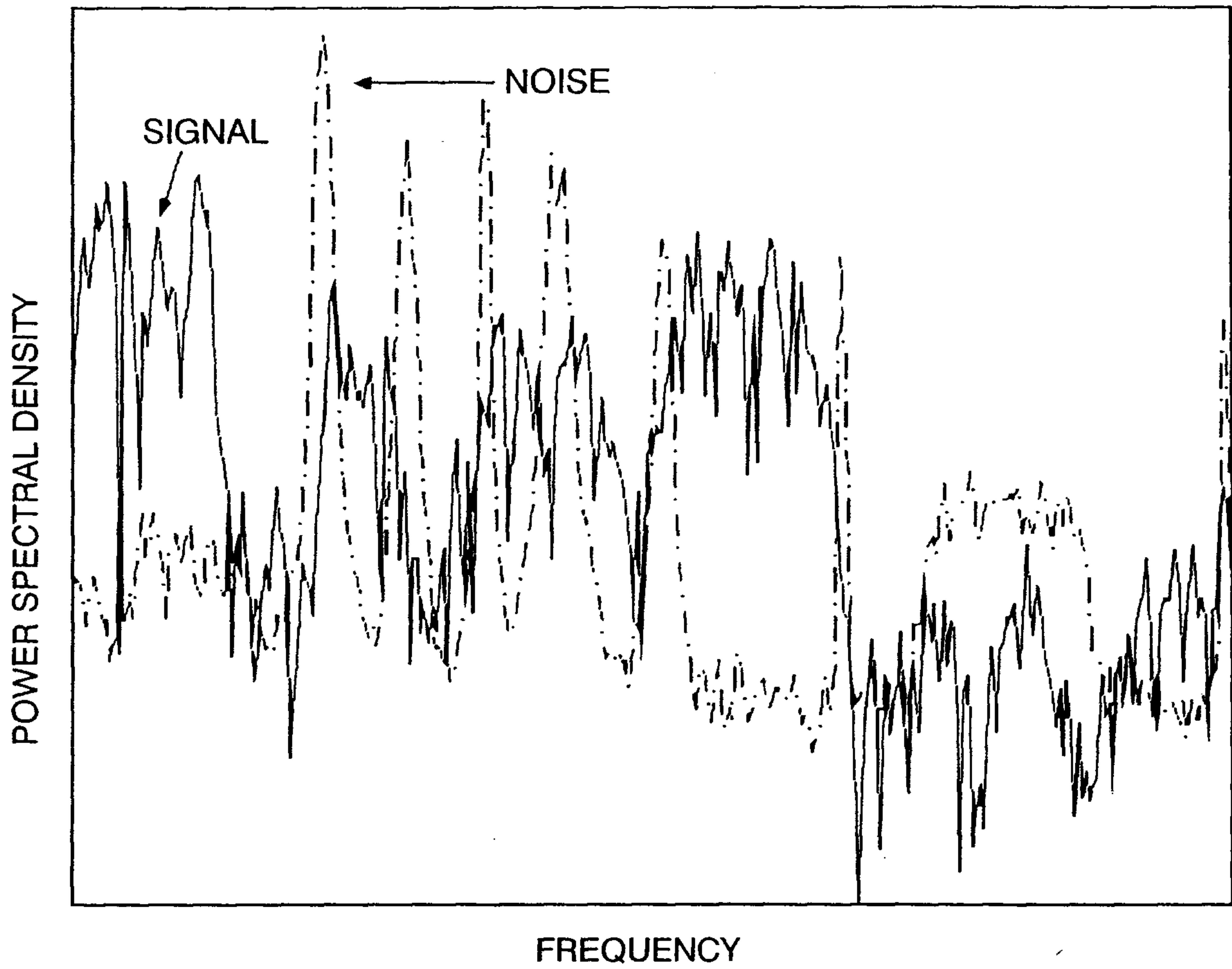

FIG.1

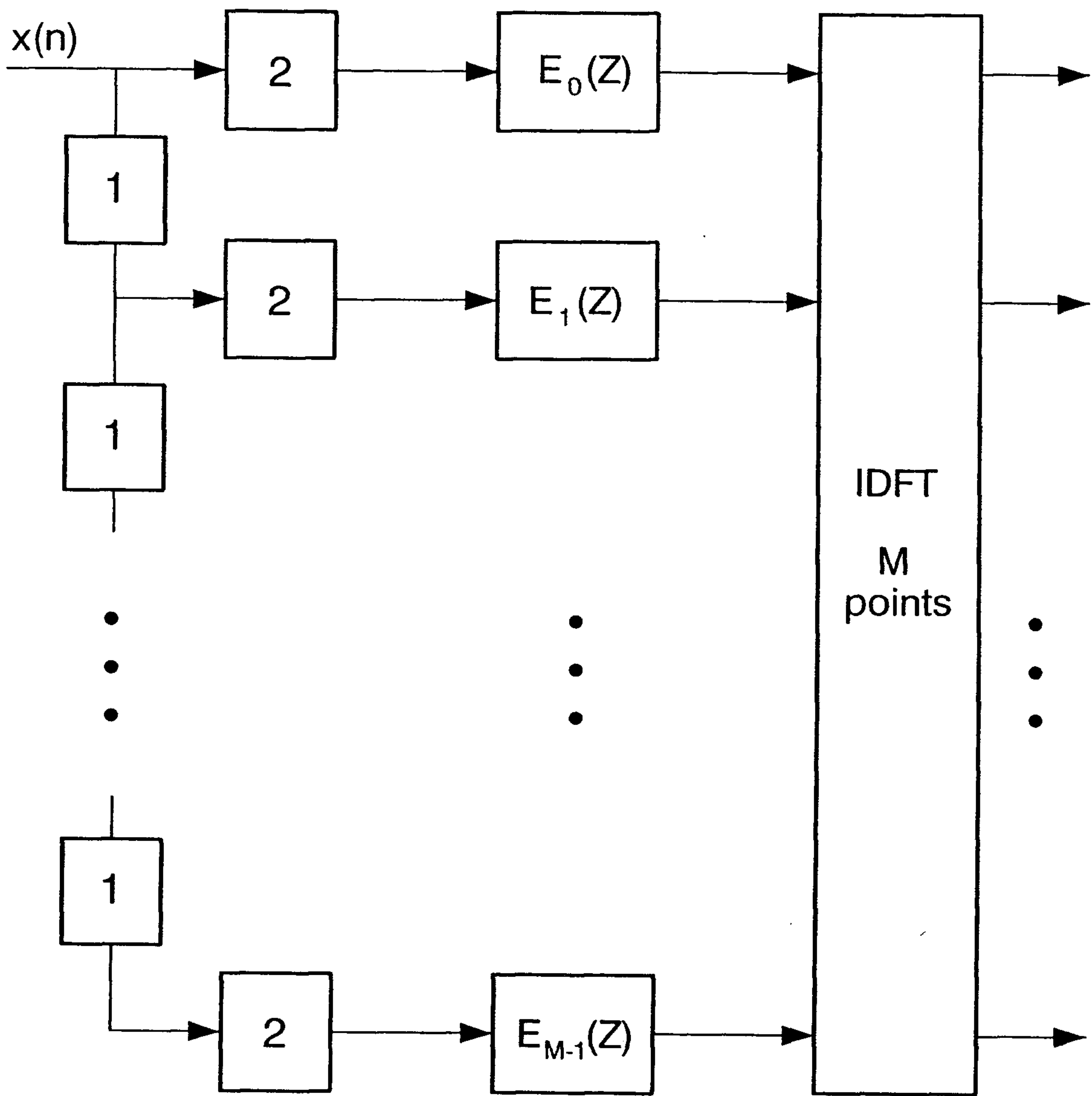

FIG.2

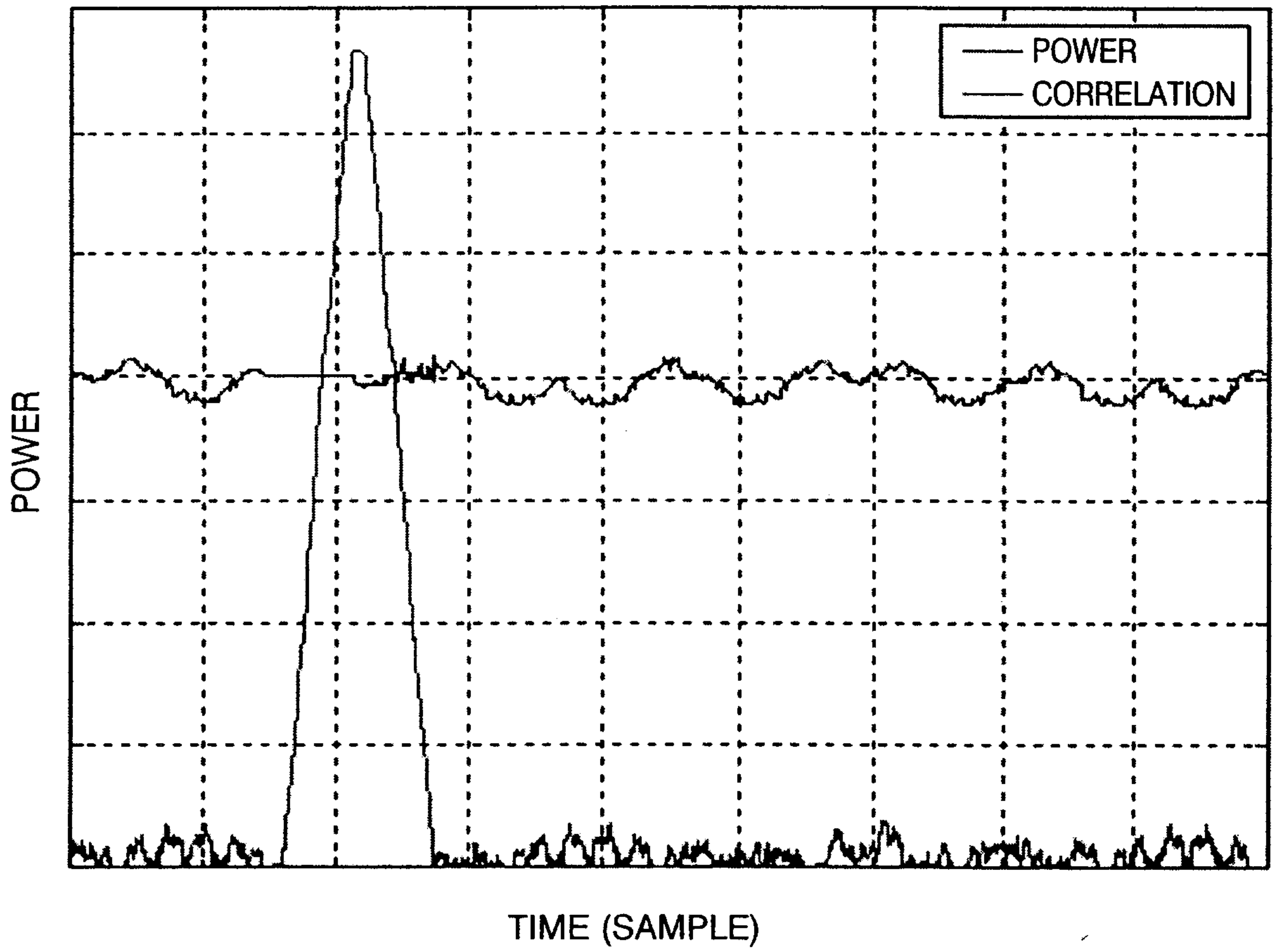

FIG.3

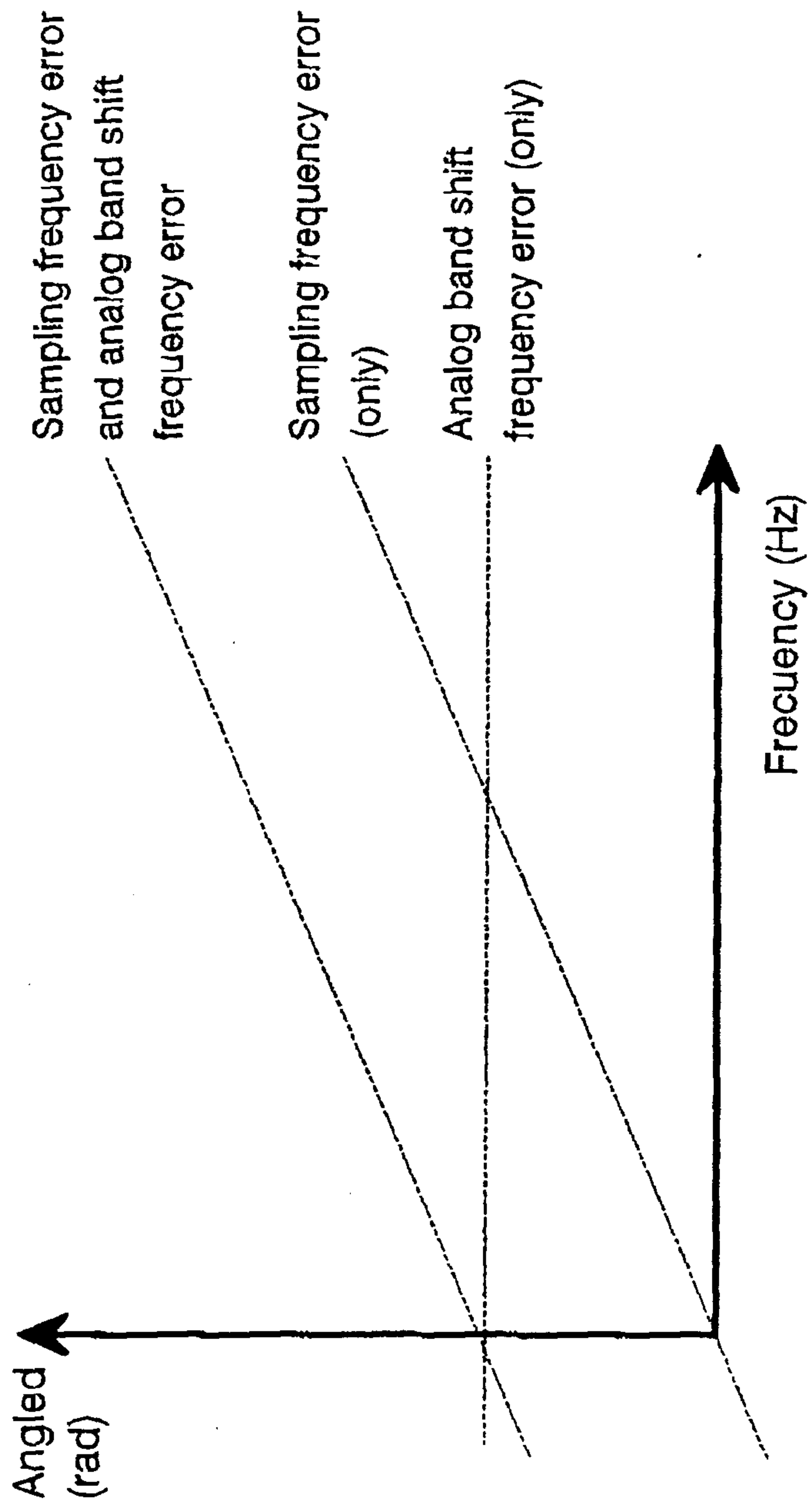

FIG.4

