

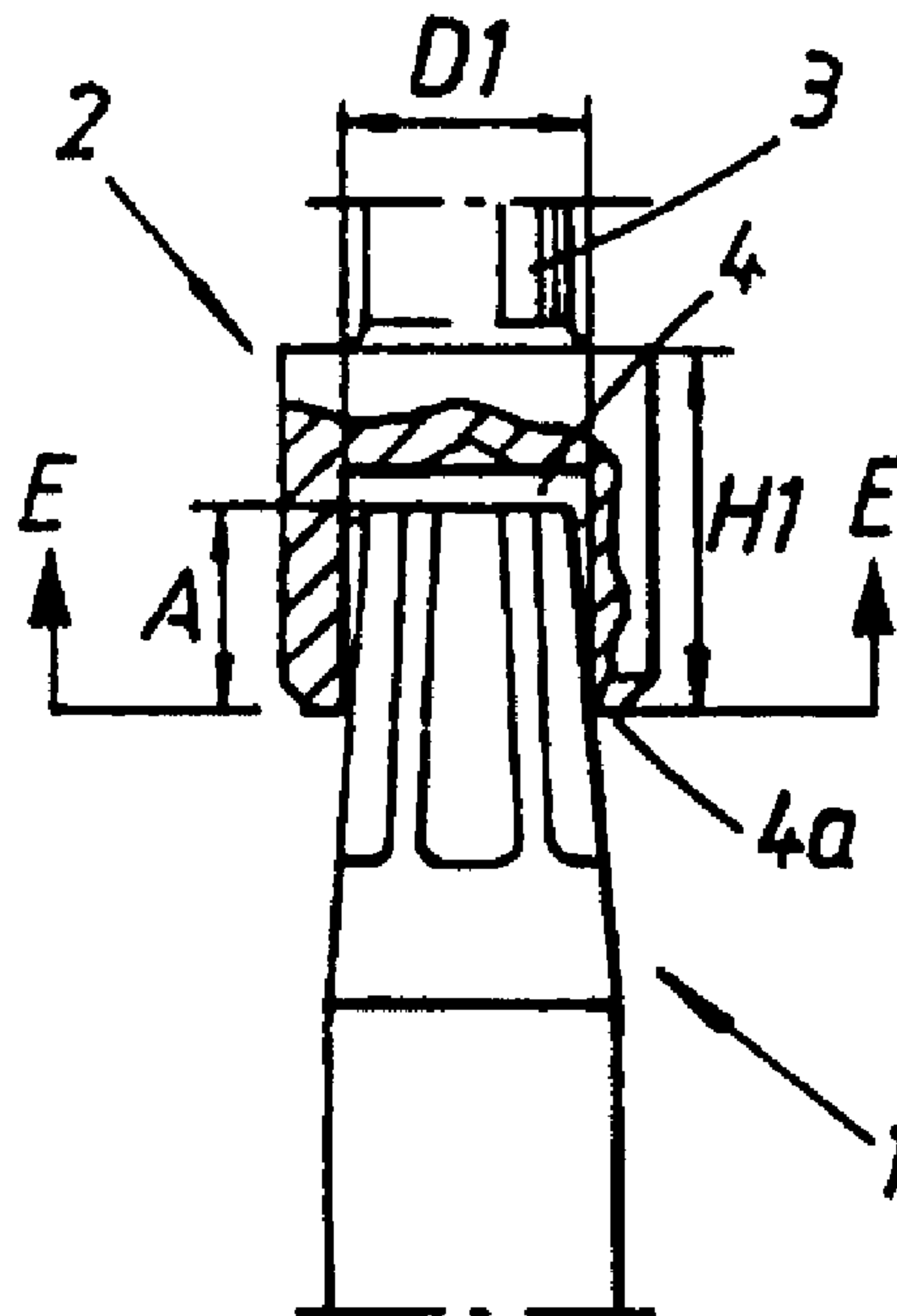

(86) Date de dépôt PCT/PCT Filing Date: 1997/08/25
 (87) Date publication PCT/PCT Publication Date: 1998/04/02
 (45) Date de délivrance/Issue Date: 2007/04/03
 (85) Entrée phase nationale/National Entry: 1999/03/23
 (86) N° demande PCT/PCT Application No.: SE 1997/001397
 (87) N° publication PCT/PCT Publication No.: 1998/012982
 (30) Priorité/Priority: 1996/09/24 (SE9603477-2)

(51) Cl.Int./Int.Cl. *A61C 8/00* (2006.01)
 (72) Inventeurs/Inventors:
 JORNEUS, LARS, SE;
 HANSSSEN, HALVAR, SE
 (73) Propriétaire/Owner:
 NOBEL BIOCARE AB, SE
 (74) Agent: FETHERSTONHAUGH & CO.

(54) Titre : AGENCEMENT POUR SYSTEME COMPORTANT UNE GAMME DE VIS DENTAIRES, ET GAMME DE VIS DENTAIRES
 (54) Title: ARRANGEMENT FOR USE IN A SYSTEM WITH A RANGE OF DENTAL SCREWS, AND THE RANGE OF DENTAL SCREWS



(57) Abrégé/Abstract:

In a system with a range of dental screws (2), the screws are tightened by means of one and the same screw tightener (1). The screws are of different types and have different constructions. Each screw has an internal recess (4) via which the cooperation with the screw tightener is afforded. Each recess has elements extending inwards towards the centre axis of the screw, and the screw tightener has parts which can cooperate with the elements. The bearing capacity function is effected by the conicity of the said parts, while the driving function between tightener and screw is effected by means of axially extending elements and parts. The driving and the bearing capacity are in this case mechanically separated. The invention may also be seen as a range of dental screws.



PCT

WORLD INTELLECTUAL PROPERTY ORGANIZATION
International Bureau

INTERNATIONAL APPLICATION PUBLISHED UNDER THE PATENT COOPERATION TREATY (PCT)

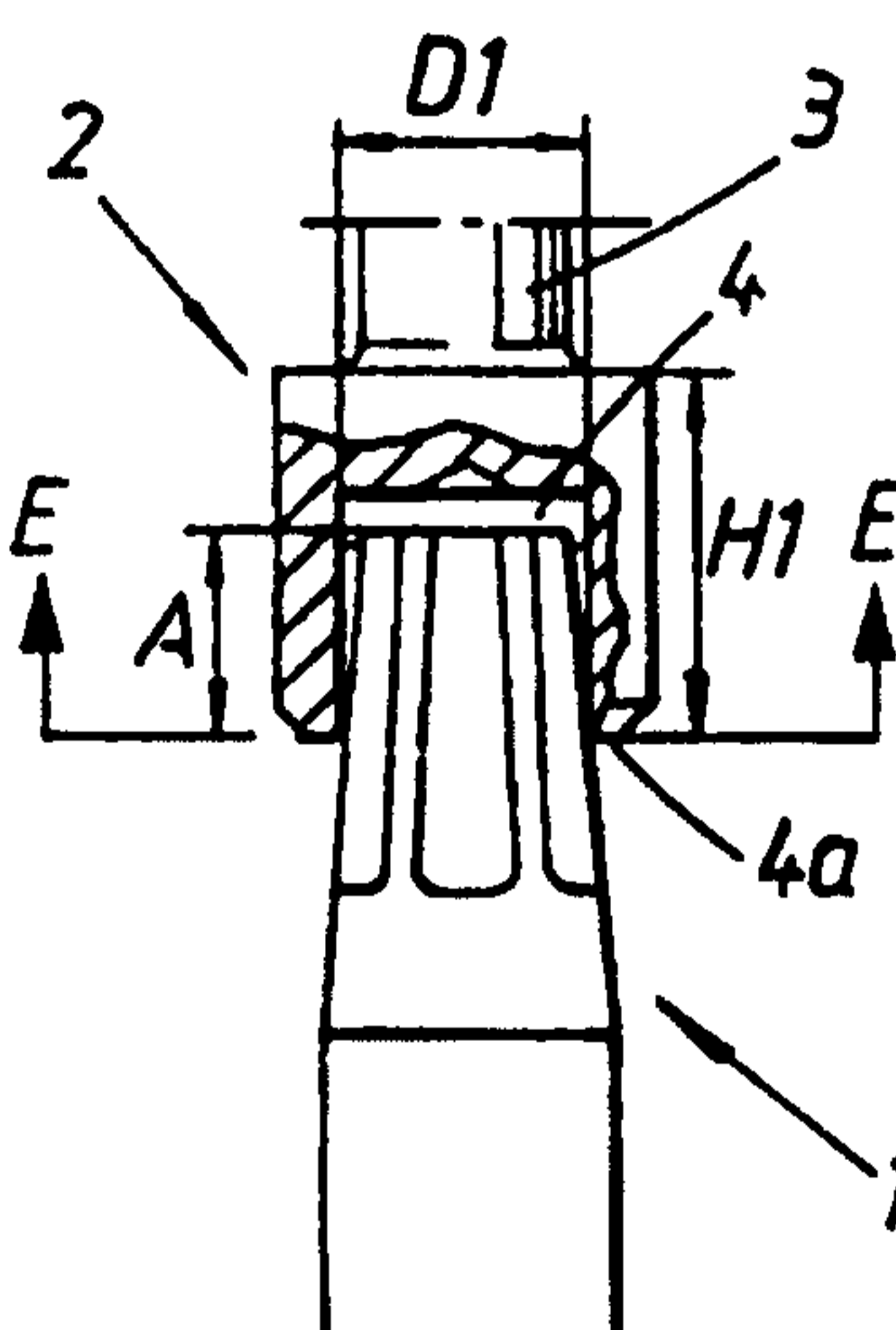
(51) International Patent Classification ⁶ : A61C 8/00	A1	(11) International Publication Number: WO 98/12982 (43) International Publication Date: 2 April 1998 (02.04.98)
(21) International Application Number: PCT/SE97/01397 (22) International Filing Date: 25 August 1997 (25.08.97) (30) Priority Data: 9603477-2 24 September 1996 (24.09.96) SE (71) Applicant (for all designated States except US): NOBEL BIOCARE AB (publ) [SE/SE]; P.O. Box 5190, S-402 26 Göteborg (SE). (72) Inventors; and (75) Inventors/Applicants (for US only): JÖRNÉUS, Lars [SE/SE]; Riabergsvägen 7B, S-403 30 Frillesås (SE). HANSSSEN, Halvar [NO/SE]; Runslingan 115, S-423 47 Göteborg (SE). (74) Agent: OLSSON, Gunnar; Nobel Biocare AB (publ), P.O. Box 5190, S-402 26 Göteborg (SE).		(81) Designated States: AU, CA, JP, US, European patent (AT, BE, CH, DE, DK, ES, FI, FR, GB, GR, IE, IT, LU, MC, NL, PT, SE). Published <i>With international search report.</i> <i>In English translation (filed in Swedish).</i>
(54) Title: ARRANGEMENT FOR USE IN A SYSTEM WITH A RANGE OF DENTAL SCREWS, AND THE RANGE OF DENTAL SCREWS (57) Abstract <p>In a system with a range of dental screws (2), the screws are tightened by means of one and the same screw tightener (1). The screws are of different types and have different constructions. Each screw has an internal recess (4) via which the cooperation with the screw tightener is afforded. Each recess has elements extending inwards towards the centre axis of the screw, and the screw tightener has parts which can cooperate with the elements. The bearing capacity function is effected by the conicity of the said parts, while the driving function between tightener and screw is effected by means of axially extending elements and parts. The driving and the bearing capacity are in this case mechanically separated. The invention may also be seen as a range of dental screws.</p> 		

WO 98/12982

PCT/SE97/01397

TITLE

1

Arrangement for use in a system with a range of dental screws, and the range of dental screws.

5

TECHNICAL FIELD

The present invention relates to an arrangement used in a system with a range of dental screws for
10 tightening the screws by means of one and the same screw tightener or screwdriver, which screws in this case consist of different types and have different constructions in terms of screwhead height, screw length, thread diameter, etc. Each screw in this case
15 has an internal recess via which the cooperation with the screw tightener is afforded. Each recess has elements extending inwards towards the centre axis of each screw, and the screw tightener has, at its end which can cooperate with the screws, parts which can
20 cooperate with the elements during screw tightening. The said elements in each recess extend, in the longitudinal direction of the recess, essentially parallel to the longitudinal axis of the screw. The invention also relates to a range of dental screws.

25

PRIOR ART

It is known that in the case of high turning moments, the tightener or screwdriver must be deeply engaged in the screwhead so that the contact surfaces
30 between the screw and the tightener are large. It is also known that in the case of dental products there is a requirement to be able to transport the screw in question, held on the tip of the tightener or screwdriver, without any risk of the screw falling off.
35 It has hitherto been proposed, inter alia, to provide each screwhead with internal elastic elements arranged at or in the recess in order to ensure the said bearing capacity function. It has also been proposed to make available a relatively large number of different
40 tighteners or screwdrivers which are intended to match

- 2 -

a small number of screws. This has led to a high degree of complexity in the system for application of implants.

5 DISCLOSURE OF THE INVENTION
TECHNICAL PROBLEM

There is general interest in reducing the number of different instruments which need to be used
10 in the application of dental implants. There is therefore a requirement for one and the same tightener or screwdriver to be able to be used for a large number of different screws. Likewise, it must also be possible to satisfy the requirement for the smallest possible
15 dimensions.

There is also a requirement for the screws and/or the screwdriver to be able to be produced in a conventional manner, without using elastic elements, O-rings or the like.

20 The object of the invention is to solve the above problems, inter alia, and it proposes new ways of creating effective driving and bearing capacity functions in this context. In the case of high driving moments, a large degree of penetration of the tightener
25 into the respective screwhead is required, and the invention is based on the recognition that the height of the screwhead or the depth of the recess must be set in relation to the driving moment requirement, while at the same time satisfying the bearing capacity function.
30 The invention solves this problem too by proposing an arrangement in which the number of tighteners or screwdrivers is balanced against the requirements regarding tightening moment and the desire for the smallest possible dimensions.

35 There is also a requirement to keep down the costs of manufacturing the screw range. The invention solves this problem too.

SOLUTION

The feature which is principally regarded as characterizing an arrangement according to the invention is that the circular cross-section of the screw tightener, at the outsides of the said parts, widens slightly conically from the said end, at the same time as the surfaces of the parts bearing against the elements are essentially parallel to corresponding surfaces of the elements.

10 In one embodiment, the invention is characterized by the fact that the recesses in the screws operated by the tightener are adapted, in accordance with each tightening moment effected by the tightener, by selecting different screwhead heights and
15 on the basis that the smallest possible dimensions are to be retained. A bearing capacity or firm wedging required between the tightener and the respective screw is also provided in this case.

An alternative way of looking at the invention shows that it can be characterized by the fact that the
20 tightener and the screws work with two functions, where the first function is a tightening function and the second function is a bearing capacity function consisting of a firm wedging occurring between the
25 tightener and each screw when the tightener is introduced into the recess of the screw, and that the first and second functions are in this case mechanically separate.

In further developments of the inventive
30 concept, it is proposed that by selecting larger recesses, the tightener is able to penetrate deeper down into each recess, and vice versa. In one embodiment, the recesses of the screws are selected with increasing diameter values seen across the whole
35 range, and the increasing values meet increasing requirements of high turning moments, and vice versa. In one embodiment, the height of the screwheads is set in relation to the driving and bearing capacity functions, so that higher screwhead heights are used

29277-13

- 4 -

for greater driving force, and vice versa, the bearing capacity being effected by the cooperation between the screwdriver and the screw material at the mouth of each recess, so that the required bearing capacity is present
5 independently of the height of the screwhead.

A range of dental screws is characterized, inter alia, by the fact that each screw is arranged to cooperate with a screw tightener whose circular cross-section, at the
10 outsides of the parts, widens slightly conically from the end. Also present on the elements there are cooperating surfaces which are essentially parallel to corresponding cooperating surfaces on the parts of the screw tightener. The range can also be characterized, inter alia, by the fact that each screw is arranged for two functions, namely a
15 tightening function and a bearing capacity function, which functions are mechanically separate.

Further characteristics and developments are evident from the subclaims which follow. Thus, for example, the screw diameters are selected in the range from
20 1 to 3 millimetres, preferably from 1.4 to 2.5 millimetres.

According to one aspect of the present invention, there is provided a dental screw arrangement used in a system with a range of dental screws for tightening the screws by means of one and the same screw tightener, which
25 screws consist of different types and have different constructions in terms of screwhead height, screw length, thread diameter, etc., and where each screw has an internal recess via which the cooperation with the screw tightener is afforded, and each recess has elements extending inwards
30 towards the centre axis of each screw, and the screw tightener has, at its end which can cooperate with the

29277-13

- 4a -

screws, parts which can cooperate with the elements during screw tightening, and the said elements in each recess extend, in the longitudinal direction of the recess, essentially parallel to the longitudinal axis of the screw, characterized in that the circular cross-section of the screw tightener, at the outsides of the said parts, widens slightly conically from the said end, at the same time as the surfaces of the parts bearing against the elements are essentially parallel to corresponding surfaces of the elements.

According to another aspect of the present invention, there is provided a dental screw arrangement used in a system with a range of dental screws for tightening the screws by means of one and the same screw tightener, which screws consist of different types and have different constructions in terms of screwhead height, screw length, thread diameter, etc., and where each screw has an internal recess via which the cooperation with the screw tightener is afforded, and each recess has elements extending inwards towards the centre axis of each screw, and the screw tightener has, at its end which can cooperate with the screws, parts which can cooperate with the elements during screw tightening, and the said elements in each recess extend, in the longitudinal direction of the recess, essentially parallel to the longitudinal axis of the screw, characterized in that the tightener and the screws work with two functions, where the first function is a tightening function and the second function is a bearing capacity function consisting of a firm wedging occurring between the tightener and each screw when the tightener is introduced into the recess of the screw, and in that the first and second functions are mechanically separate.

29277-13

- 4b -

According to still another aspect of the present invention, there is provided range of dental screws which can be tightened by means of one and the same screw tightener, where the screws consist of different types and have different constructions in terms of screwhead height, screw length, thread diameter, etc., and where each screw has an internal recess via which the cooperation with the screw tightener is afforded, and each recess has elements extending inwards towards the centre axis of each screw and can cooperate with end parts on the screw tightener, and the said elements in each recess extend, in the longitudinal direction of the recess, essentially parallel to the longitudinal axis of the screw, characterized in that each screw is arranged to cooperate with a screw tightener whose circular cross-section, at the outsides of the said parts, widens slightly conically from the said end, and in that surfaces located on the elements are essentially parallel to corresponding cooperating surfaces on the said end parts.

According to yet another aspect of the present invention, there is provided range of dental screws which can be tightened by means of one and the same screw tightener, where the screws consist of different types and have different constructions in terms of screwhead height, screw length, thread diameter, etc., and where each screw has an internal recess via which the cooperation with the screw tightener is afforded, and each recess has elements extending inwards towards the centre axis of each screw and can cooperate with end parts on the screw tightener, and the said elements in each recess extend, in the longitudinal direction of the recess, essentially parallel to the longitudinal axis of the screw, characterized in that each screw is arranged to work with two functions, where the first function is the screw's tightening function and the

29277-13

- 4c -

second function is a bearing capacity function consisting of a firm wedging of the screw occurring in the tightener when the screw receives the tightener in its recess, and in that the first and second functions are mechanically separate.

5 ADVANTAGES

A great benefit is gained by virtue of the fact that the number of tighteners or screwdrivers can be reduced for the same number of different screws. The manufacturing accuracy or the tolerances are adapted to the driving and bearing capacity requirements, which affords advantages from the manufacturing and cost aspects seen across the whole range. The invention is based on the use of tighteners of the screwdriver type, but the screws in question can also be operated using conventional hexagonal drivers (multi-edge drivers).

DESCRIPTION OF THE FIGURES

A presently proposed embodiment of an arrangement which has the significant characteristic

- 5 -

features of the invention will be described hereinbelow with reference to the attached drawings, in which:

Figures 1 - 4 show, in vertical views, those parts of a tightener or screwdriver which can cooperate with screws of different types, the tightener or screwdriver end engaging in an internal recess in each screw, and the screwdriver in question being able to operate different types of screws,

Figures 5 - 6a show, in vertical and end views, front parts of screwdrivers of the novel design and of the known design, respectively, so as to illustrate the mechanical separation of the driving and bearing capacity functions in the first-mentioned case,

Figures 7 - 8 show, in different end views, screwheads operated by conventional hexagonal spanners,

Figures 10 - 10a show, in vertical and end views, and separate from the screw, the front parts of a screwdriver of the first embodiment, and

Figures 11 - 11a show, in vertical and end views, and separate from the screwdriver, a screw according to Figure 4.

DETAILED EMBODIMENT

Figure 1 shows the front parts of a tightener labelled 1. The tightener is partially engaged in a screwhead 2, the screw part of which is partly shown by 3. The screwhead has an internal recess 4. The screwhead has a height H1 and the internal recess has a diameter D1. Figures 2, 3 and 4 show in a corresponding manner that the same tightener 1', 1'' and 1''', respectively, is brought into engagement with other types of screws 2', 2'' and 2''', respectively, which in a corresponding manner have screw parts 3', 3'' and 3''', respectively. In this case, the recesses have the diameters D2, D3 and D4, respectively, and the heights H2, H3 and H4, respectively.

Figure 4 shows the screwdriver 1''' in its entirety, its front parts being brought into engagement with a further type of screw 2''' which has a screw

part 3''', recess diameter D4 and height H4. The different Figures 1 - 4 show that there can be different degrees of engagement A, A', A'' and A''', respectively.

5 Figures 1a and 10, 10a show the design of the tightener at the end which can cooperate with the respective screwhead. The tightener or the screwdriver is provided with six radially protruding parts 5, 6, 7, 8, 9 and 10. The outsides 5a, 6a, 7a, 8a, 9a and 10a of
10 these parts are cone-shaped and widen from the end surface 1a of the tightener (see Figure 4) out towards the holding part 1b of the tightener (see Figure 4). This conicity of the parts 5 - 10 forms part of a bearing capacity function which is described
15 hereinafter. The said parts 5 - 10 are connected to one another via arc-shaped portions 5b, 6b, 7b, 8b, 9b and 10b. These portions extend essentially parallel to the centre axis 11 of the tightener (cf. also Figure 4). The arc-shaped portions 5b - 10b form part of the
20 driving function between the tightener and the respective screw according to Figures 1 - 4, 11 and 11a.

 Figure 10a indicates a radius R for each arc-shaped portion 5b - 10b (cf. Figure 1a). In the present
25 illustrative embodiment, this radius is selected as $4.0 + 0.05$ mm. Figure 10a also indicates a distance B between diametrically opposite arc-shaped portions (7b and 10b according to Figure 1a). In the present case, B is selected as $1.18 + 0.02$. Figure 10a also shows a
30 diameter C between the outsides of two diametrically opposite parts (in this case 6a and 9a). In the illustrative embodiment, C is selected as 1.48 ± 0.02 . According to Figures 11 - 11a, this is produced with corresponding tolerances at corresponding values for
35 B', C' and R', respectively.

 Figure 1a shows the screw 3 in cooperation with the tightener or screwdriver 1 applied in the internal recess 4 of the screw 2, as above. Compare also Figures 11 and 11a. The screw is designed with elements 12a,

12b, 12c, 12d, 12f and 12g which extend inwards towards the centre 16 and which are formed with arc shapes matching the arc shapes of the parts 5b - 10b. These elements 12a - 12g extend parallel to the longitudinal axis 16 of the nut/tightener. These elements form part of the driving function between tightener and nut. The surfaces of the elements 12a - 12g are shown by 12a', 12b', 12c', 12d', 12f' and 12g'. These elements or surfaces cooperate with the surfaces 5b - 10b according to Figure 1a. This figure shows a case where the tolerance between the elements 12a - 12g of the screw and the portions 5a - 10a of the tightener is small. In this case, the radii R for the elements on the screws and the parts on the tightener are formed with great precision. The bearing capacity which is essentially or completely independent of the driving surfaces is effected by the screwdriver's surfaces 5c, 6c, 7c, 8c, 9c, 10c at the mouth 4a of the recesses 4 (see Figure 1). The bearing capacity is effected by means of the firm-wedging function between the material of the screwdriver and the respective screw concerned.

Figure 6 shows the case where the tolerances between the said elements and parts are greater. Thus, the radius R for the parts according to Figure 4a is 0.375, while the radius for the elements according to Figure 5 is = 0.425.

The tolerance between the elements and the parts in accordance with the above can be varied. In an alternative case, the radius R = 0.85 mm, while radius R for the elements is = 0.45 mm. Figures 1 - 4 illustrate the different depths of penetration of the screwdrivers into different screws. The bearing capacities are illustrated for the above case by 4a', 4a'' and 4a'''.

Figure 7 shows the case where a screw 17' is acted upon by a conventional cross-slotted screwdriver 18'.e.

Figure 8 shows the prior art in which a screw 17 is operated by a conventional hexagonal spanner 18.

In accordance with Figure 9, the screw design 19 according to the invention can be operated by such a hexagonal spanner 20. The depth of penetration for such hexagonal spanners can be made different in this case
5 too.

According to Figures 1 - 4, the heights H1 - H4 are set in relation to the depths of penetration A' - A'''. A greater value of H1 gives a greater depth of penetration. Exceptions may however be possible.

10 Screwdrivers which can operate the screws in accordance with the above are indicated by 21 and 22 in Figures 5a and 6a, respectively. The length of the driving and bearing capacity surfaces 21a and 21b is indicated by L1 in the case according to Figures 5 and
15 5a. In the case according to Figure 5 there is a short, cone-shaped part 23 which connects the surfaces 21a and 21b. Figures 5, 5a show how the driving and bearing capacity surfaces are mechanically separated. The screwdriver 22 belongs to the prior art and is intended
20 to act on screwheads according to Figure 7. The bearing capacity function by means of inclined/cone-shaped surfaces is not present here, which means that there are substantial manufacturing demands in order to achieve the bearing capacity. In this case, the driving
25 and bearing capacity functions are not separated.

The invention is not limited to the embodiment which has been shown hereinabove by way of example, but instead can be modified within the scope of the attached patent claims and the inventive concept.

29277-13

- 9 -

CLAIMS:

1. A dental screw arrangement used in a system with a range of dental screws for tightening the screws by means of one and the same screw tightener, which screws consist of
5 different types and have different constructions in terms of screwhead height, screw length, thread diameter, etc., and where each screw has an internal recess via which the cooperation with the screw tightener is afforded, and each recess has elements extending inwards towards the centre
10 axis of each screw, and the screw tightener has, at its end which can cooperate with the screws, parts which can cooperate with the elements during screw tightening, and the said elements in each recess extend, in the longitudinal direction of the recess, essentially parallel to the
15 longitudinal axis of the screw, characterized in that the circular cross-section of the screw tightener, at the outsides of the said parts, widens slightly conically from the said end, at the same time as the surfaces of the parts bearing against the elements are essentially parallel to
20 corresponding surfaces of the elements.

2. A dental screw arrangement used in a system with a range of dental screws for tightening the screws by means of one and the same screw tightener, which screws consist of
25 different types and have different constructions in terms of screwhead height, screw length, thread diameter, etc., and where each screw has an internal recess via which the cooperation with the screw tightener is afforded, and each recess has elements extending inwards towards the centre axis of each screw, and the screw tightener has, at its end
30 which can cooperate with the screws, parts which can cooperate with the elements during screw tightening, and the

29277-13

- 10 -

said elements in each recess extend, in the longitudinal direction of the recess, essentially parallel to the longitudinal axis of the screw, characterized in that the tightener and the screws work with two functions, where the
5 first function is a tightening function and the second function is a bearing capacity function consisting of a firm wedging occurring between the tightener and each screw when the tightener is introduced into the recess of the screw, and in that the first and second functions are mechanically
10 separate.

3. Arrangement according to Patent Claim 1 or 2, characterized in that by selecting larger recesses, the tightener is able to penetrate deeper down into each recess, and vice versa.

15 4. Arrangement according to Patent Claim 1, 2 or 3, characterized in that the recesses of the screws are selected with increasing diameter values seen across the whole range, and in that the increasing values meet increasing requirements of high turning moments, and vice
20 versa.

5. Arrangement according to Patent Claim 4, characterized in that the higher turning moments within the screw range are of the order of magnitude of 50 Newton centimetre.

25 6. Arrangement according to any one of Claims 1 to 5, characterized in that in cases where a high tightening moment is required, the screwhead height and/or the recess depth is/are selected so as to establish sizes of formed driving surfaces, i.e. high tightening moments are assigned
30 correspondingly large driving surfaces.

29277-13

- 11 -

7. Arrangement according to any one of Claims 1 to 6, characterized in that the screw diameters are of the order of magnitude of 1 - 3 millimetres, preferably 1.4 - 2.5 millimetres.
- 5 8. Arrangement according to any one of Claims 1 to 7, characterized in that the driving functions of the tightener and of the screws are arranged with axial extents, and in that the bearing capacity function for the tightener utilizes cone-shaped or sloping extents.
- 10 9. Arrangement according to any one of Claims 1 to 8, characterized in that the bearing capacity function can be established at the mouth of the recess of each screwhead by cooperation between the screwdriver and screw material in the firm-wedging function, the cone-shaped and sloping
15 surfaces being arranged to effect a bearing capacity function essentially independent of the screwhead height or recess depth.
10. Arrangement according to any one of Claims 1 to 9, characterized in that the heights of the screwheads are set
20 in relation to the driving functions, so that higher screwhead heights are used for greater driving force, and vice versa.
11. Range of dental screws which can be tightened by means of one and the same screw tightener, where the screws
25 consist of different types and have different constructions in terms of screwhead height, screw length, thread diameter, etc., and where each screw has an internal recess via which the cooperation with the screw tightener is afforded, and each recess has elements extending inwards towards the
30 centre axis of each screw and can cooperate with end parts on the screw tightener, and the said elements in each recess extend, in the longitudinal direction of the recess,

29277-13

- 12 -

essentially parallel to the longitudinal axis of the screw, characterized in that each screw is arranged to cooperate with a screw tightener whose circular cross-section, at the outsides of the said parts, widens slightly conically from the said end, and in that surfaces located on the elements are essentially parallel to corresponding cooperating surfaces on the said end parts.

12. Range of dental screws which can be tightened by means of one and the same screw tightener, where the screws consist of different types and have different constructions in terms of screwhead height, screw length, thread diameter, etc., and where each screw has an internal recess via which the cooperation with the screw tightener is afforded, and each recess has elements extending inwards towards the centre axis of each screw and can cooperate with end parts on the screw tightener, and the said elements in each recess extend, in the longitudinal direction of the recess, essentially parallel to the longitudinal axis of the screw, characterized in that each screw is arranged to work with two functions, where the first function is the screw's tightening function and the second function is a bearing capacity function consisting of a firm wedging of the screw occurring in the tightener when the screw receives the tightener in its recess, and in that the first and second functions are mechanically separate.

FETHERSTONHAUGH & CO.

OTTAWA, CANADA

PATENT AGENTS

Fig. 1

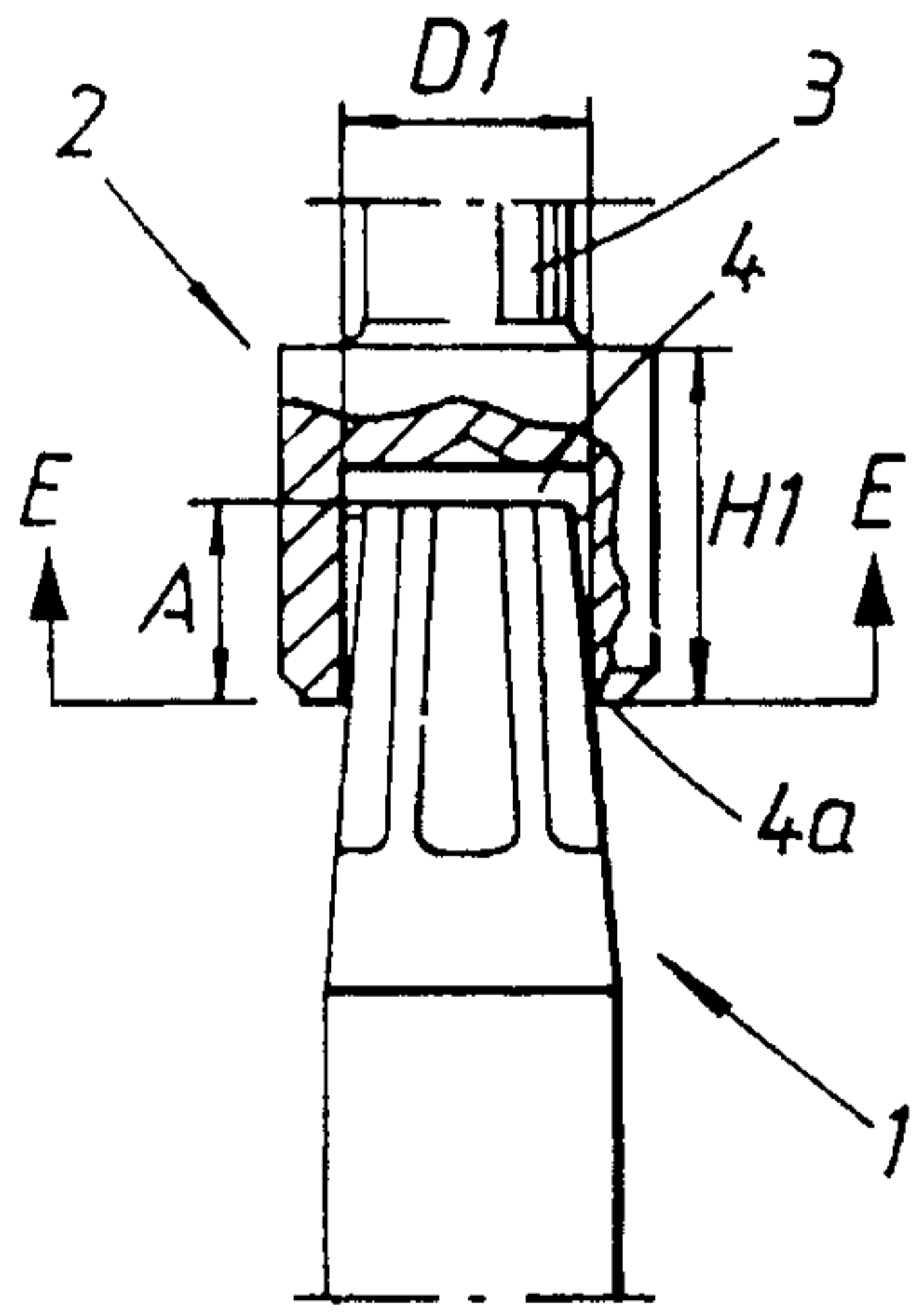

Fig. 1a

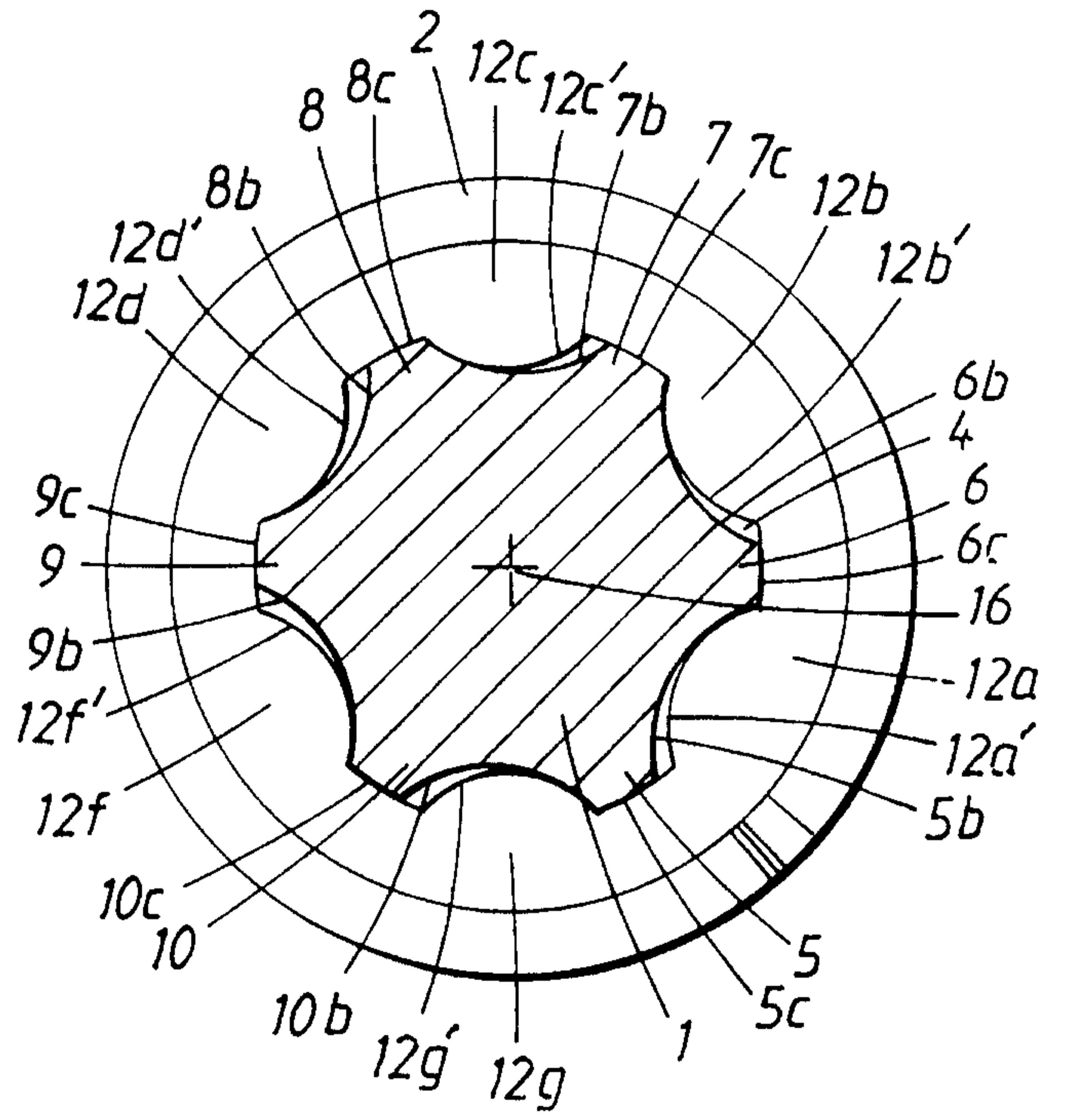

Fig. 2

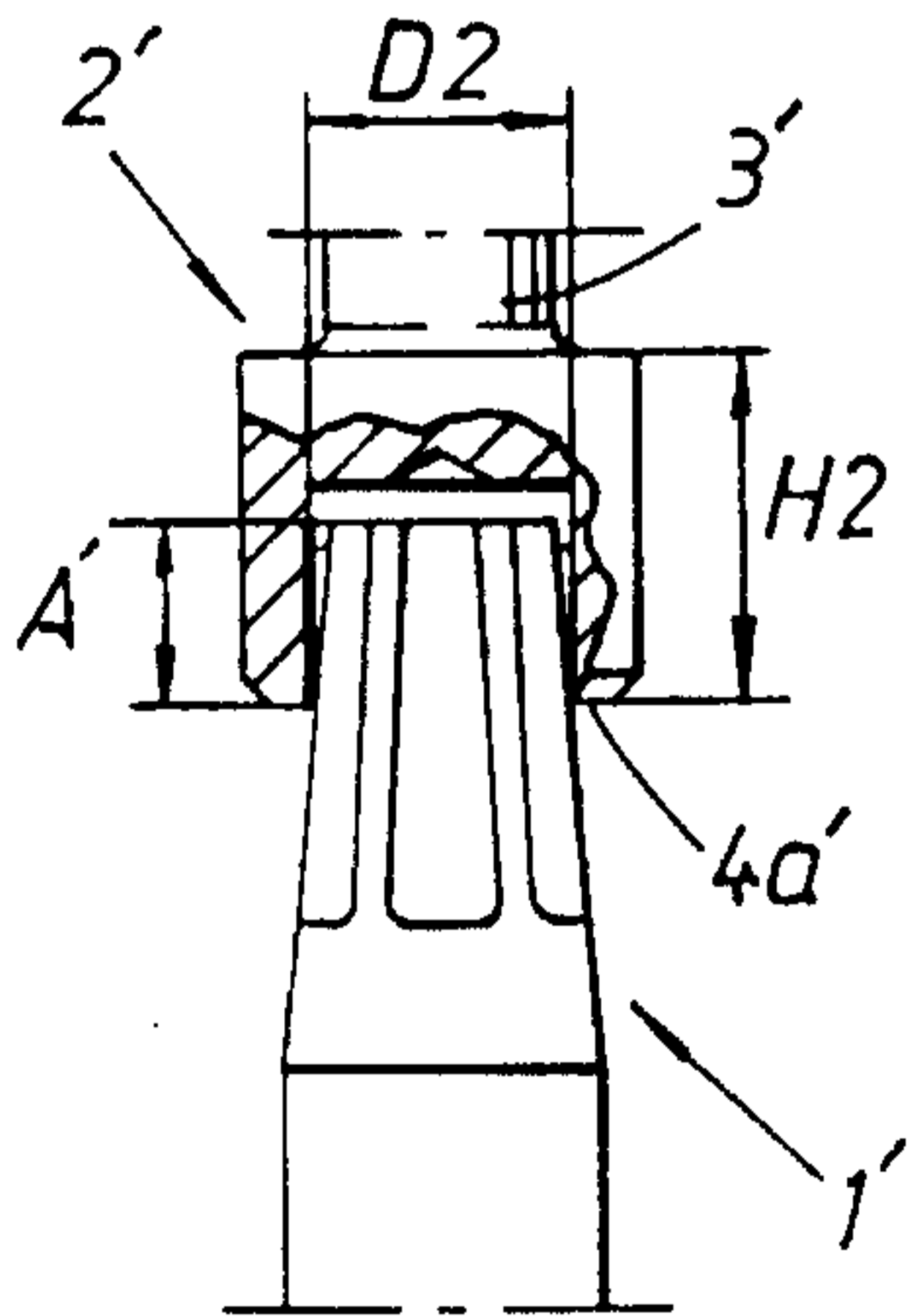

Fig. 3

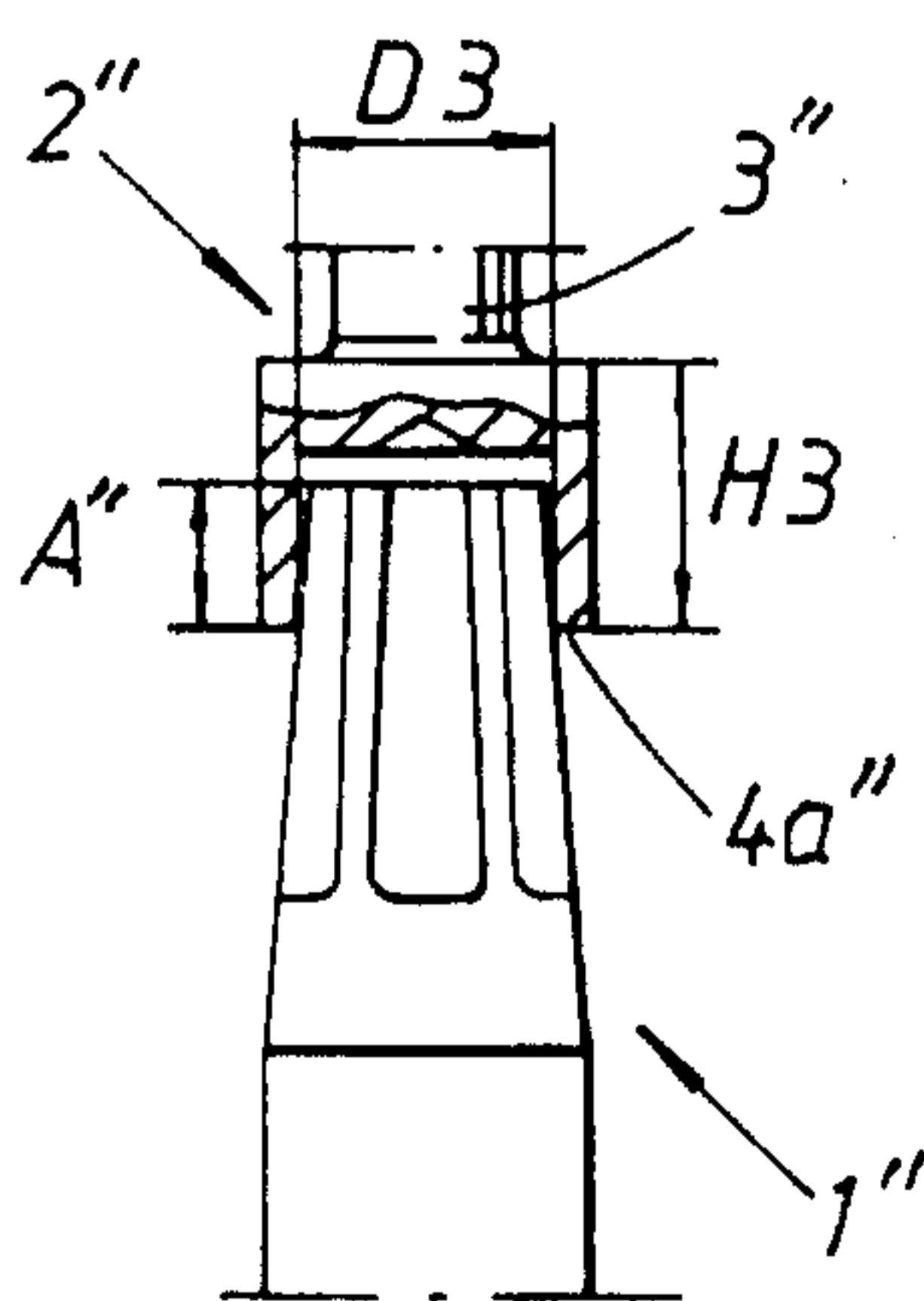
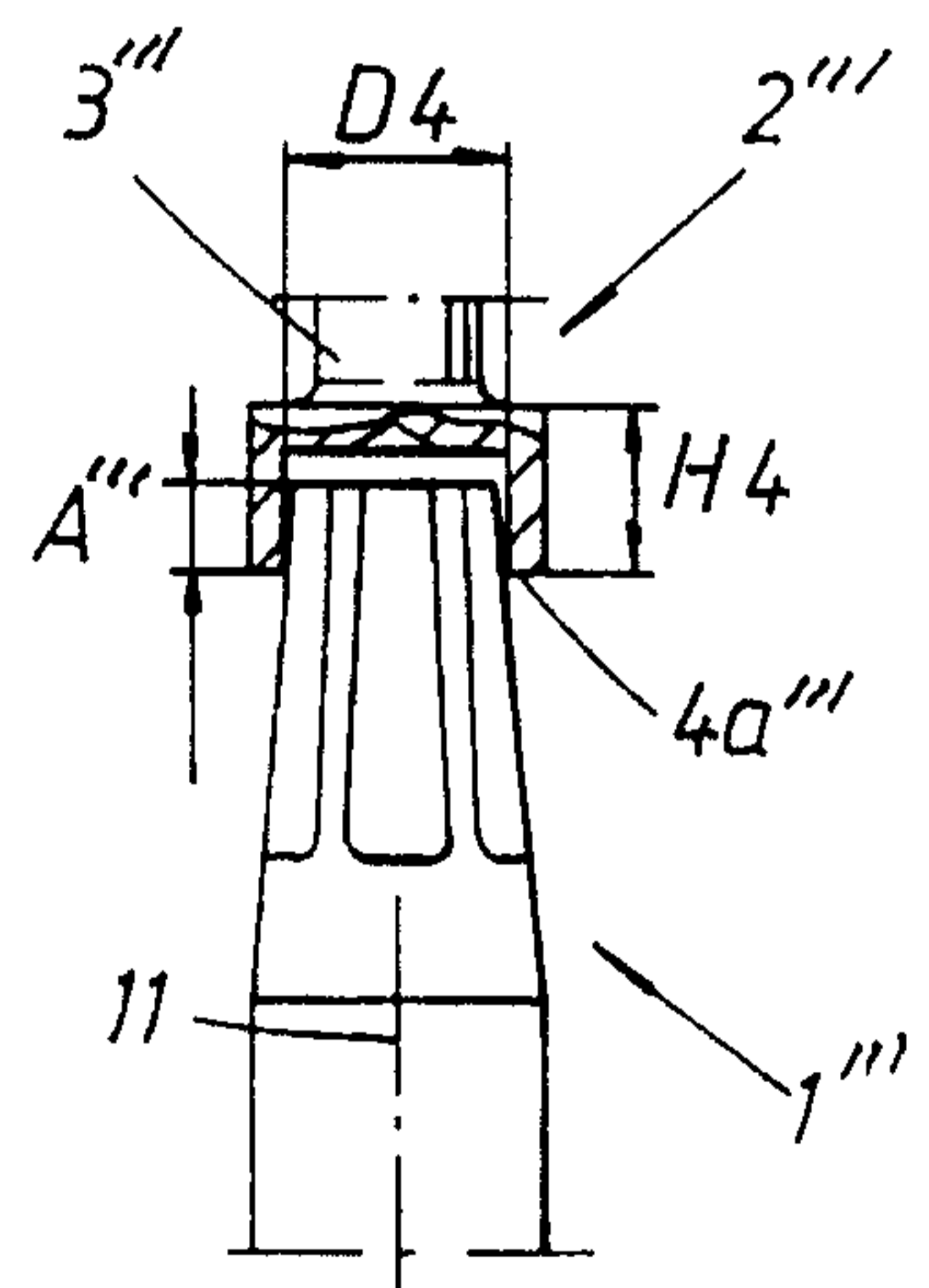

Fig. 4



2/2

