



- (51) International Patent Classification: *H04W 72/04* (2009.01)
- (21) International Application Number: PCT/CN2018/071683
- (22) International Filing Date: 06 January 2018 (06.01.2018)
- (25) Filing Language: English
- (26) Publication Language: English
- (30) Priority Data: PCT/CN2017/070429
06 January 2017 (06.01.2017) CN
- (71) Applicant: **QUALCOMM INCORPORATED** [US/US];
Attn: International IP Administration, 5775 Morehouse Drive,
San Diego, CA 92121-1714 (US).
- (72) Inventors; and
(71) Applicants (for US only): **ZHANG, Yu** [CN/CN]; 5775
Morehouse Drive, San Diego, CA 92121-1714 (US). **WEI,
Chao** [CN/CN]; 5775 Morehouse Drive, San Diego, CA
92121-1714 (US). **XU, Hao** [US/CN]; 5775 Morehouse
Drive, San Diego, CA 92121-1714 (US). **CHEN, Wan-
shi** [CN/US]; 5775 Morehouse Drive, San Diego, CA
- 92121-1714 (US). **ZENG, Wei**; 19999 Stevens Creek
Blvd., Unit 119, Cupertino, CA 95014 (US).
- (74) Agent: **NTD PATENT & TRADEMARK AGENCY
LIMITED**; 10th Floor, Block A, Investment Plaza, 27 Jin-
rongdajie, Xicheng District, Beijing 100033 (CN).
- (81) Designated States (unless otherwise indicated, for every
kind of national protection available): AE, AG, AL, AM,
AO, AT, AU, AZ, BA, BB, BG, BH, BN, BR, BW, BY, BZ,
CA, CH, CL, CN, CO, CR, CU, CZ, DE, DJ, DK, DM, DO,
DZ, EC, EE, EG, ES, FI, GB, GD, GE, GH, GM, GT, HN,
HR, HU, ID, IL, IN, IR, IS, JO, JP, KE, KG, KH, KN, KP,
KR, KW, KZ, LA, LC, LK, LR, LS, LU, LY, MA, MD, ME,
MG, MK, MN, MW, MX, MY, MZ, NA, NG, NI, NO, NZ,
OM, PA, PE, PG, PH, PL, PT, QA, RO, RS, RU, RW, SA,
SC, SD, SE, SG, SK, SL, SM, ST, SV, SY, TH, TJ, TM, TN,
TR, TT, TZ, UA, UG, US, UZ, VC, VN, ZA, ZM, ZW.
- (84) Designated States (unless otherwise indicated, for every
kind of regional protection available): ARIPO (BW, GH,
GM, KE, LR, LS, MW, MZ, NA, RW, SD, SL, ST, SZ, TZ,
UG, ZM, ZW), Eurasian (AM, AZ, BY, KG, KZ, RU, TJ,
TM), European (AL, AT, BE, BG, CH, CY, CZ, DE, DK,
EE, ES, FI, FR, GB, GR, HR, HU, IE, IS, IT, LT, LU, LV,
MC, MK, MT, NL, NO, PL, PT, RO, RS, SE, SI, SK, SM,

(54) Title: TRANSMITTING SOUNDING REFERENCE SIGNALS IN NEW RADIO

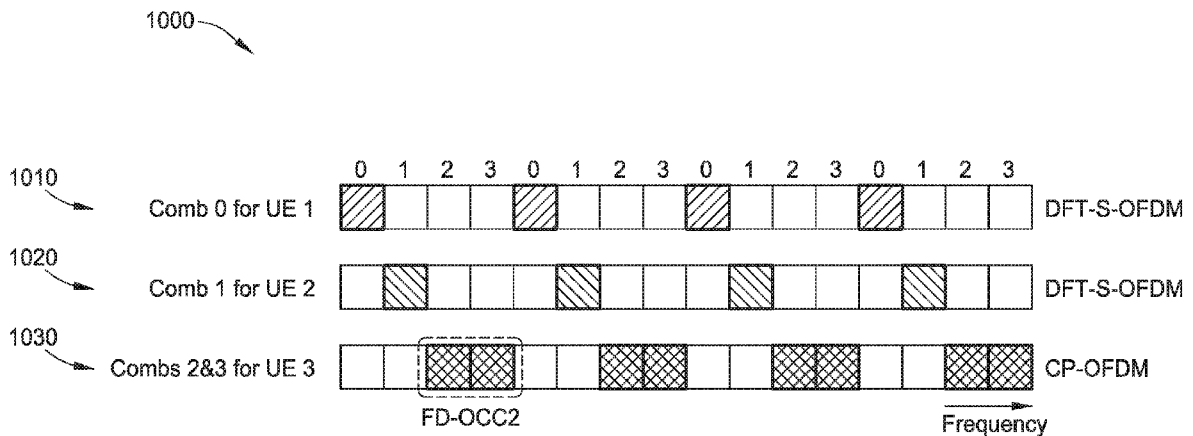

FIG. 10

(57) Abstract: Certain aspects of the present disclosure relate to methods and apparatus for transmitting sounding reference signals (SRS) in communications systems operating according to new radio (NR) technologies. An exemplary method that a user equipment (UE) may perform includes determining whether to transmit a sounding reference signal (SRS) using a discrete Fourier transform (DFT) spread orthogonal frequency domain multiplexing (DFT-S-OFDM) waveform or a cyclic prefix orthogonal frequency domain multiplexing (CP-OFDM) waveform, and transmitting the SRS using the determined waveform.



TR), OAPI (BF, BJ, CF, CG, CI, CM, GA, GN, GQ, GW,
KM, ML, MR, NE, SN, TD, TG).

Declarations under Rule 4.17:

— *of inventorship (Rule 4.17(iv))*

Published:

— *with international search report (Art. 21(3))*

TRANSMITTING SOUNDING REFERENCE SIGNALS IN NEW RADIO

[0001] This application claims priority to International Application No. PCT/CN2017/070429 filed January 6, 2017, which is assigned to the assignee of the present application and is expressly incorporated by reference herein in its entirety.

Field

[0002] The present disclosure relates generally to communication systems, and more particularly, to methods and apparatus for transmitting sounding reference signals (SRS) in communications systems operating according to new radio (NR) technologies.

Background

[0003] Wireless communication systems are widely deployed to provide various telecommunication services such as telephony, video, data, messaging, and broadcasts. Typical wireless communication systems may employ multiple-access technologies capable of supporting communication with multiple users by sharing available system resources (e.g., bandwidth, transmit power). Examples of such multiple-access technologies include Long Term Evolution (LTE) systems, code division multiple access (CDMA) systems, time division multiple access (TDMA) systems, frequency division multiple access (FDMA) systems, orthogonal frequency division multiple access (OFDMA) systems, single-carrier frequency division multiple access (SC-FDMA) systems, and time division synchronous code division multiple access (TD-SCDMA) systems.

[0004] In some examples, a wireless multiple-access communication system may include a number of base stations, each simultaneously supporting communication for multiple communication devices, otherwise known as user equipment (UEs). In LTE or LTE-A network, a set of one or more base stations may define an eNodeB (eNB). In other examples (e.g., in a next generation or 5G network), a wireless multiple access communication system may include a number of distributed units (DUs) (e.g., edge units (EUs), edge nodes (ENs), radio heads (RHs), smart radio heads (SRHs), transmission reception points (TRPs), etc.) in communication with a number of central units (CUs) (e.g., central nodes (CNs), access node controllers (ANCs), etc.), where a set of one or more distributed units, in communication with a central unit, may define an access node (e.g., a new radio base station (NR BS), a new radio node-B (NR NB), a

network node, 5G NB, eNB, etc.). A base station or DU may communicate with a set of UEs on downlink channels (e.g., for transmissions from a base station or to a UE) and uplink channels (e.g., for transmissions from a UE to a base station or distributed unit).

[0005] These multiple access technologies have been adopted in various telecommunication standards to provide a common protocol that enables different wireless devices to communicate on a municipal, national, regional, and even global level. An example of an emerging telecommunication standard is new radio (NR), for example, 5G radio access. NR is a set of enhancements to the LTE mobile standard promulgated by Third Generation Partnership Project (3GPP). It is designed to better support mobile broadband Internet access by improving spectral efficiency, lowering costs, improving services, making use of new spectrum, and better integrating with other open standards using OFDMA with a cyclic prefix (CP) on the downlink (DL) and on the uplink (UL) as well as support beamforming, multiple-input multiple-output (MIMO) antenna technology, and carrier aggregation.

[0006] However, as the demand for mobile broadband access continues to increase, there exists a need for further improvements in NR technology. Preferably, these improvements should be applicable to other multi-access technologies and the telecommunication standards that employ these technologies.

BRIEF SUMMARY

[0007] The systems, methods, and devices of the disclosure each have several aspects, no single one of which is solely responsible for its desirable attributes. Without limiting the scope of this disclosure as expressed by the claims which follow, some features will now be discussed briefly. After considering this discussion, and particularly after reading the section entitled "Detailed Description" one will understand how the features of this disclosure provide advantages that include improved communications between access points and stations in a wireless network.

[0008] Certain aspects of the present disclosure generally relate to methods and apparatus for transmitting sounding reference signals (SRS). The SRS may provide information concerning the uplink channel which allows frequency dependent scheduling on the uplink by a base station, NodeB, or eNodeB. In one example, the SRS may be used to measure the uplink channel quality over a portion of the uplink

channel bandwidth. A UE may be instructed by an eNodeB to transmit the SRS across a particular portion of the uplink channel bandwidth.

[0009] Certain aspects provide a method for wireless communication by a user equipment. The method generally includes determining whether to transmit a sounding reference signal (SRS) using a discrete Fourier transform (DFT) spread orthogonal frequency domain multiplexing (DFT-S-OFDM) waveform or a cyclic prefix orthogonal frequency domain multiplexing (CP-OFDM) waveform, and transmitting the SRS using the determined waveform.

[0010] Certain aspects provide a method for wireless communication by a base station. The method generally includes determining whether a user equipment (UE) is to transmit a sounding reference signal (SRS) using a discrete Fourier transform (DFT) spread orthogonal frequency domain multiplexing (DFT-S-OFDM) waveform or a cyclic prefix orthogonal frequency domain multiplexing (CP-OFDM) waveform, sending an indication of the determined waveform to the UE, and processing the SRS, based on the determined waveform.

[0011] Certain aspects provide an apparatus for wireless communication. The apparatus generally includes a processor configured to determine whether to transmit a sounding reference signal (SRS) using a discrete Fourier transform (DFT) spread orthogonal frequency domain multiplexing (DFT-S-OFDM) waveform or a cyclic prefix orthogonal frequency domain multiplexing (CP-OFDM) waveform, and to cause the apparatus to transmit the SRS using the determined waveform, and a memory coupled with the processor.

[0012] Certain aspects provide an apparatus for wireless communication. The apparatus generally includes a processor configured to determine whether a user equipment (UE) is to transmit a sounding reference signal (SRS) using a discrete Fourier transform (DFT) spread orthogonal frequency domain multiplexing (DFT-S-OFDM) waveform or a cyclic prefix orthogonal frequency domain multiplexing (CP-OFDM) waveform, to cause the apparatus to send an indication of the determined waveform to the UE, and to process the SRS, based on the determined waveform, and a memory coupled with the processor.

[0013] Aspects generally include methods, apparatus, systems, computer readable mediums, and processing systems, as substantially described herein with reference to and as illustrated by the accompanying drawings.

[0014] To the accomplishment of the foregoing and related ends, the one or more aspects comprise the features hereinafter fully described and particularly pointed out in the claims. The following description and the annexed drawings set forth in detail certain illustrative features of the one or more aspects. These features are indicative, however, of but a few of the various ways in which the principles of various aspects may be employed, and this description is intended to include all such aspects and their equivalents.

BRIEF DESCRIPTION OF THE DRAWINGS

[0015] So that the manner in which the above-recited features of the present disclosure can be understood in detail, a more particular description, briefly summarized above, may be had by reference to aspects, some of which are illustrated in the appended drawings. It is to be noted, however, that the appended drawings illustrate only certain typical aspects of this disclosure and are therefore not to be considered limiting of its scope, for the description may admit to other equally effective aspects.

[0016] FIG. 1 is a block diagram conceptually illustrating an example telecommunications system, in accordance with certain aspects of the present disclosure.

[0017] FIG. 2 is a block diagram illustrating an example logical architecture of a distributed RAN, in accordance with certain aspects of the present disclosure.

[0018] FIG. 3 is a diagram illustrating an example physical architecture of a distributed RAN, in accordance with certain aspects of the present disclosure.

[0019] FIG. 4 is a block diagram conceptually illustrating a design of an example BS and user equipment (UE), in accordance with certain aspects of the present disclosure.

[0020] FIG. 5 is a diagram showing examples for implementing a communication protocol stack, in accordance with certain aspects of the present disclosure.

[0021] FIG. 6 illustrates an example of a DL-centric subframe, in accordance with certain aspects of the present disclosure.

[0022] FIG. 7 illustrates an example of an UL-centric subframe, in accordance with certain aspects of the present disclosure.

[0023] FIGs. 8A and 8B illustrate example operations for wireless communications, in accordance with certain aspects of the present disclosure.

[0024] FIG. 9 example operations for wireless communications, in accordance with aspects of the present disclosure.

[0025] FIG. 10 illustrates a technique for multiplexing SRSs using different waveforms in frequency, in accordance with certain aspects of the present disclosure.

[0026] FIG. 11 illustrates a technique for transmitting an SRS, in accordance with certain aspects of the present disclosure.

[0027] FIG. 12 illustrates a technique for determining a waveform for transmitting an SRS, in accordance with certain aspects of the present disclosure.

[0028] FIG. 13 illustrates a technique for determining a waveform for transmitting an SRS, in accordance with certain aspects of the present disclosure.

[0029] FIG. 14 illustrates a technique for determining a waveform for transmitting an SRS, in accordance with certain aspects of the present disclosure.

[0030] To facilitate understanding, identical reference numerals have been used, where possible, to designate identical elements that are common to the figures. It is contemplated that elements disclosed in one aspect may be beneficially utilized on other aspects without specific recitation.

DETAILED DESCRIPTION

[0031] Aspects of the present disclosure provide apparatus, methods, processing systems, and computer readable mediums for new radio (NR) (new radio access technology or 5G technology).

[0032] NR may support various wireless communication services, such as Enhanced mobile broadband (eMBB) targeting wide bandwidth (e.g., 80 MHz and wider), millimeter wave (mmW) targeting high carrier frequency (e.g., 27 GHz and higher), massive MTC (mMTC) targeting non-backward compatible MTC techniques, and/or mission critical targeting ultra-reliable low latency communications (URLLC). These services may include latency and reliability requirements. These services may also have different transmission time intervals (TTI) to meet respective quality of service (QoS) requirements. In addition, these services may co-exist in the same subframe.

[0033] Aspects of the present disclosure relate to transmitting sounding reference signals (SRS). According to aspects of the present disclosure, a network (e.g., a network entity, such as a BS) may decide and communicate to a UE which one of cyclic prefix orthogonal frequency domain multiplexing (CP-OFDM) and discrete Fourier transform spread orthogonal frequency domain multiplexing (DFT-S-OFDM) based waveforms the UE should use when transmitting (e.g., transmitting SRS) to the network. In one example, UEs support both CP-OFDM and DFT-S-OFDM based waveforms.

[0034] The following description provides examples, and is not limiting of the scope, applicability, or examples set forth in the claims. Changes may be made in the function and arrangement of elements discussed without departing from the scope of the disclosure. Various examples may omit, substitute, or add various procedures or components as appropriate. For instance, the methods described may be performed in an order different from that described, and various steps may be added, omitted, or combined. Also, features described with respect to some examples may be combined in some other examples. For example, an apparatus may be implemented or a method may be practiced using any number of the aspects set forth herein. In addition, the scope of the disclosure is intended to cover such an apparatus or method which is practiced using other structure, functionality, or structure and functionality in addition to or other than the various aspects of the disclosure set forth herein. It should be understood that any aspect of the disclosure disclosed herein may be embodied by one or more elements of a claim. The word “exemplary” is used herein to mean “serving as an example, instance, or illustration.” Any aspect described herein as “exemplary” is not necessarily to be construed as preferred or advantageous over other aspects.

[0035] The techniques described herein may be used for various wireless communication networks such as LTE, CDMA, TDMA, FDMA, OFDMA, SC-FDMA and other networks. The terms “network” and “system” are often used interchangeably. A CDMA network may implement a radio technology such as Universal Terrestrial Radio Access (UTRA), cdma2000, etc. UTRA includes Wideband CDMA (WCDMA) and other variants of CDMA. cdma2000 covers IS-2000, IS-95 and IS-856 standards. A TDMA network may implement a radio technology such as Global System for Mobile Communications (GSM). An OFDMA network may implement a radio technology such as NR (e.g. 5G RA), Evolved UTRA (E-UTRA), Ultra Mobile Broadband (UMB), IEEE 802.11 (Wi-Fi), IEEE 802.16 (WiMAX), IEEE 802.20, Flash-OFDMA, etc. UTRA and E-UTRA are part of Universal Mobile Telecommunication System (UMTS). NR is an emerging wireless communications technology under development in conjunction with the 5G Technology Forum (5GTF). 3GPP Long Term Evolution (LTE) and LTE-Advanced (LTE-A) are releases of UMTS that use E-UTRA. UTRA, E-UTRA, UMTS, LTE, LTE-A and GSM are described in documents from an organization named “3rd Generation Partnership Project” (3GPP). cdma2000 and UMB are described in documents from an organization named “3rd Generation Partnership Project 2” (3GPP2). The techniques described herein may be used for the wireless networks and radio technologies mentioned above as well as other wireless networks and radio technologies. For clarity, while aspects may be described herein using terminology commonly associated with 3G and/or 4G wireless technologies, aspects of the present disclosure can be applied in other generation-based communication systems, such as 5G and later, including NR technologies.

EXAMPLE WIRELESS COMMUNICATIONS SYSTEM

[0036] FIG. 1 illustrates an example wireless network 100, such as a new radio (NR) or 5G network, in which aspects of the present disclosure may be performed, for example, for enabling connectivity sessions and internet protocol (IP) establishment, as described in greater detail below.

[0037] As illustrated in FIG. 1, the wireless network 100 may include a number of BSs 110 and other network entities. A BS may be a station that communicates with UEs. Each BS 110 may provide communication coverage for a particular geographic area. In 3GPP, the term “cell” can refer to a coverage area of a Node B and/or a Node B

subsystem serving this coverage area, depending on the context in which the term is used. In NR systems, the term “cell” and eNB, Node B, 5G NB, AP, NR BS, NR BS, or TRP may be interchangeable. In some examples, a cell may not necessarily be stationary, and the geographic area of the cell may move according to the location of a mobile base station. In some examples, the base stations may be interconnected to one another and/or to one or more other base stations or network nodes (not shown) in the wireless network 100 through various types of backhaul interfaces such as a direct physical connection, a virtual network, or the like using any suitable transport network.

[0038] In general, any number of wireless networks may be deployed in a given geographic area. Each wireless network may support a particular radio access technology (RAT) and may operate on one or more frequencies. A RAT may also be referred to as a radio technology, an air interface, etc. A frequency may also be referred to as a carrier, a frequency channel, etc. Each frequency may support a single RAT in a given geographic area in order to avoid interference between wireless networks of different RATs. In some cases, NR or 5G RAT networks may be deployed.

[0039] A BS may provide communication coverage for a macro cell, a pico cell, a femto cell, and/or other types of cell. A macro cell may cover a relatively large geographic area (e.g., several kilometers in radius) and may allow unrestricted access by UEs with service subscription. A pico cell may cover a relatively small geographic area and may allow unrestricted access by UEs with service subscription. A femto cell may cover a relatively small geographic area (e.g., a home) and may allow restricted access by UEs having association with the femto cell (e.g., UEs in a Closed Subscriber Group (CSG), UEs for users in the home, etc.). A BS for a macro cell may be referred to as a macro BS. A BS for a pico cell may be referred to as a pico BS. A BS for a femto cell may be referred to as a femto BS or a home BS. In the example shown in FIG. 1, the BSs 110a, 110b and 110c may be macro BSs for the macro cells 102a, 102b and 102c, respectively. The BS 110x may be a pico BS for a pico cell 102x. The BSs 110y and 110z may be femto BS for the femto cells 102y and 102z, respectively. A BS may support one or multiple (e.g., three) cells.

[0040] The wireless network 100 may also include relay stations. A relay station is a station that receives a transmission of data and/or other information from an upstream station (e.g., a BS or a UE) and sends a transmission of the data and/or other

information to a downstream station (e.g., a UE or a BS). A relay station may also be a UE that relays transmissions for other UEs. In the example shown in FIG. 1, a relay station 110r may communicate with the BS 110a and a UE 120r in order to facilitate communication between the BS 110a and the UE 120r. A relay station may also be referred to as a relay BS, a relay, etc.

[0041] The wireless network 100 may be a heterogeneous network that includes BSs of different types, e.g., macro BS, pico BS, femto BS, relays, etc. These different types of BSs may have different transmit power levels, different coverage areas, and different impact on interference in the wireless network 100. For example, macro BS may have a high transmit power level (e.g., 20 Watts) whereas pico BS, femto BS, and relays may have a lower transmit power level (e.g., 1 Watt).

[0042] The wireless network 100 may support synchronous or asynchronous operation. For synchronous operation, the BSs may have similar frame timing, and transmissions from different BSs may be approximately aligned in time. For asynchronous operation, the BSs may have different frame timing, and transmissions from different BSs may not be aligned in time. The techniques described herein may be used for both synchronous and asynchronous operation.

[0043] A network controller 130 may be coupled to a set of BSs and provide coordination and control for these BSs. The network controller 130 may communicate with the BSs 110 via a backhaul. The BSs 110 may also communicate with one another, e.g., directly or indirectly via wireless or wireline backhaul.

[0044] The UEs 120 (e.g., 120x, 120y, etc.) may be dispersed throughout the wireless network 100, and each UE may be stationary or mobile. A UE may also be referred to as a mobile station, a terminal, an access terminal, a subscriber unit, a station, a Customer Premises Equipment (CPE), a cellular phone, a smart phone, a personal digital assistant (PDA), a wireless modem, a wireless communication device, a handheld device, a laptop computer, a cordless phone, a wireless local loop (WLL) station, a tablet, a camera, a gaming device, a netbook, a smartbook, an ultrabook, a medical device or medical equipment, a biometric sensor and/or device, a wearable device such as a smart watch, smart clothing, smart glasses, a smart wrist band, smart jewelry (e.g., a smart ring, a smart bracelet, etc.), an entertainment device (e.g., a music

device, a video device, a satellite radio, etc.), a vehicular component or sensor, a smart meter and/or sensor, industrial manufacturing equipment, a global positioning system device, or any other suitable device that is configured to communicate via a wireless or wired medium. Some UEs may be considered evolved or machine-type communication (MTC) devices or evolved MTC (eMTC) devices. MTC and eMTC UEs include, for example, robots, drones, remote devices, sensors, meters, monitors, location tags, etc., that may communicate with a BS, another device (e.g., remote device), or some other entity. A wireless node may provide, for example, connectivity for or to a network (e.g., a wide area network such as Internet or a cellular network) via a wired or wireless communication link. Some UEs may be considered Internet-of-Things (IoT) devices.

[0045] In FIG. 1, a solid line with double arrows indicates desired transmissions between a UE and a serving BS, which is a BS designated to serve the UE on the downlink and/or uplink. A dashed line with double arrows indicates interfering transmissions between a UE and a BS.

[0046] Certain wireless networks (e.g., LTE) utilize orthogonal frequency division multiplexing (OFDM) on the downlink and single-carrier frequency division multiplexing (SC-FDM) on the uplink. OFDM and SC-FDM partition the system bandwidth into multiple (K) orthogonal subcarriers, which are also commonly referred to as tones, bins, etc. Each subcarrier may be modulated with data. In general, modulation symbols are sent in the frequency domain with OFDM and in the time domain with SC-FDM. The spacing between adjacent subcarriers may be fixed, and the total number of subcarriers (K) may be dependent on the system bandwidth. For example, the spacing of the subcarriers may be 15 kHz and the minimum resource allocation (called a 'resource block') may be 12 subcarriers (or 180 kHz). Consequently, the nominal FFT size may be equal to 128, 256, 512, 1024 or 2048 for system bandwidth of 1.25, 2.5, 5, 10 or 20 megahertz (MHz), respectively. The system bandwidth may also be partitioned into subbands. For example, a subband may cover 1.08 MHz (i.e., 6 resource blocks), and there may be 1, 2, 4, 8 or 16 subbands for system bandwidth of 1.25, 2.5, 5, 10 or 20 MHz, respectively.

[0047] While aspects of the examples described herein may be associated with LTE technologies, aspects of the present disclosure may be applicable with other wireless communications systems, such as NR. NR may utilize OFDM with a CP on the uplink

and downlink and include support for half-duplex operation using time division duplex (TDD). A single component carrier bandwidth of 100 MHz may be supported. NR resource blocks may span 12 sub-carriers with a sub-carrier bandwidth of 75 kHz over a 0.1 ms duration. Each radio frame may consist of 50 subframes with a length of 10 ms. Consequently, each subframe may have a length of 0.2 ms. Each subframe may indicate a link direction (i.e., DL or UL) for data transmission and the link direction for each subframe may be dynamically switched. Each subframe may include DL and/or UL user data as well as DL and/or UL control data. UL and DL subframes for NR may be as described in more detail below with respect to FIGs. 6 and 7. Beamforming may be supported and beam direction may be dynamically configured. MIMO transmissions with precoding may also be supported. MIMO configurations in the DL may support up to 8 transmit antennas with multi-layer DL transmissions up to 8 streams and up to 2 streams per UE. Multi-layer transmissions with up to 2 streams per UE may be supported. Aggregation of multiple cells may be supported with up to 8 serving cells. Alternatively, NR may support a different air interface, other than an OFDM-based. NR networks may include entities such as CUs and/or DUs.

[0048] In some examples, access to the air interface may be scheduled, wherein a scheduling entity (e.g., a base station) allocates resources for communication among some or all devices and equipment within its service area or cell. Within the present disclosure, as discussed further below, the scheduling entity may be responsible for scheduling, assigning, reconfiguring, and releasing resources for one or more subordinate entities. That is, for scheduled communication, subordinate entities utilize resources allocated by the scheduling entity. Base stations are not the only entities that may function as a scheduling entity. That is, in some examples, a UE may function as a scheduling entity, scheduling resources for one or more subordinate entities (e.g., one or more other UEs). In this example, the UE is functioning as a scheduling entity, and other UEs utilize resources scheduled by the UE for wireless communication. A UE may function as a scheduling entity in a peer-to-peer (P2P) network, and/or in a mesh network. In a mesh network example, UEs may optionally communicate directly with one another in addition to communicating with the scheduling entity.

[0049] Thus, in a wireless communication network with a scheduled access to time-frequency resources and having a cellular configuration, a P2P configuration, and a

mesh configuration, a scheduling entity and one or more subordinate entities may communicate utilizing the scheduled resources.

[0050] As noted above, a RAN may include a CU and DUs. A NR BS (e.g., eNB, 5G Node B, Node B, transmission reception point (TRP), access point (AP)) may correspond to one or multiple BSs. NR cells can be configured as access cell (ACells) or data only cells (DCells). For example, the RAN (e.g., a central unit or distributed unit) can configure the cells. DCells may be cells used for carrier aggregation or dual connectivity, but not used for initial access, cell selection/reselection, or handover. In some cases DCells may not transmit synchronization signals—in some case cases DCells may transmit SS. NR BSs may transmit downlink signals to UEs indicating the cell type. Based on the cell type indication, the UE may communicate with the NR BS. For example, the UE may determine NR BSs to consider for cell selection, access, handover, and/or measurement based on the indicated cell type.

[0051] FIG. 2 illustrates an example logical architecture of a distributed radio access network (RAN) 200, which may be implemented in the wireless communication system illustrated in FIG. 1. A 5G access node 206 may include an access node controller (ANC) 202. The ANC may be a central unit (CU) of the distributed RAN 200. The backhaul interface to the next generation core network (NG-CN) 204 may terminate at the ANC. The backhaul interface to neighboring next generation access nodes (NG-ANs) may terminate at the ANC. The ANC may include one or more TRPs 208 (which may also be referred to as BSs, NR BSs, Node Bs, 5G NBs, APs, or some other term). As described above, a TRP may be used interchangeably with “cell.”

[0052] The TRPs 208 may be a DU. The TRPs may be connected to one ANC (ANC 202) or more than one ANC (not illustrated). For example, for RAN sharing, radio as a service (RaaS), and service specific AND deployments, the TRP may be connected to more than one ANC. A TRP may include one or more antenna ports. The TRPs may be configured to individually (e.g., dynamic selection) or jointly (e.g., joint transmission) serve traffic to a UE.

[0053] The local architecture 200 may be used to illustrate fronthaul definition. The architecture may be defined that support fronthauling solutions across different

deployment types. For example, the architecture may be based on transmit network capabilities (e.g., bandwidth, latency, and/or jitter).

[0054] The architecture may share features and/or components with LTE. According to aspects, the next generation AN (NG-AN) 210 may support dual connectivity with NR. The NG-AN may share a common fronthaul for LTE and NR.

[0055] The architecture may enable cooperation between and among TRPs 208. For example, cooperation may be preset within a TRP and/or across TRPs via the ANC 202. According to aspects, no inter-TRP interface may be needed or present.

[0056] According to aspects, a dynamic configuration of split logical functions may be present within the architecture 200. As will be described in more detail with reference to FIG. 5, the Radio Resource Control (RRC) layer, Packet Data Convergence Protocol (PDCP) layer, Radio Link Control (RLC) layer, Medium Access Control (MAC) layer, and a Physical (PHY) layers may be adaptably placed at the DU or CU (e.g., TRP or ANC, respectively). According to certain aspects, a BS may include a central unit (CU) (e.g., ANC 202) and/or one or more distributed units (e.g., one or more TRPs 208).

[0057] FIG. 3 illustrates an example physical architecture of a distributed RAN 300, according to aspects of the present disclosure. A centralized core network unit (C-CU) 302 may host core network functions. The C-CU may be centrally deployed. C-CU functionality may be offloaded (e.g., to advanced wireless services (AWS)), in an effort to handle peak capacity.

[0058] A centralized RAN unit (C-RU) 304 may host one or more ANC functions. Optionally, the C-RU may host core network functions locally. The C-RU may have distributed deployment. The C-RU may be closer to the network edge.

[0059] A DU 306 may host one or more TRPs (edge node (EN), an edge unit (EU), a radio head (RH), a smart radio head (SRH), or the like). The DU may be located at edges of the network with radio frequency (RF) functionality.

[0060] FIG. 4 illustrates example components of the BS 110 and UE 120 illustrated in FIG. 1, which may be used to implement aspects of the present disclosure. As described above, the BS may include a TRP. One or more components of the BS 110

and UE 120 may be used to practice aspects of the present disclosure. For example, antennas 452, Tx/Rx 222, processors 466, 458, 464, and/or controller/processor 480 of the UE 120 and/or antennas 434, processors 460, 420, 438, and/or controller/processor 440 of the BS 110 may be used to perform the operations described herein and illustrated with reference to FIGs. 8A, 8B, and 9.

[0061] FIG. 4 shows a block diagram of a design of a BS 110 and a UE 120, which may be one of the BSs and one of the UEs in FIG. 1. For a restricted association scenario, the base station 110 may be the macro BS 110c in FIG. 1, and the UE 120 may be the UE 120y. The base station 110 may also be a base station of some other type. The base station 110 may be equipped with antennas 434a through 434t, and the UE 120 may be equipped with antennas 452a through 452r.

[0062] At the base station 110, a transmit processor 420 may receive data from a data source 412 and control information from a controller/processor 440. The control information may be for the Physical Broadcast Channel (PBCH), Physical Control Format Indicator Channel (PCFICH), Physical Hybrid ARQ Indicator Channel (PHICH), Physical Downlink Control Channel (PDCCH), etc. The data may be for the Physical Downlink Shared Channel (PDSCH), etc. The processor 420 may process (e.g., encode and symbol map) the data and control information to obtain data symbols and control symbols, respectively. The processor 420 may also generate reference symbols, e.g., for the PSS, SSS, and cell-specific reference signal. A transmit (TX) multiple-input multiple-output (MIMO) processor 430 may perform spatial processing (e.g., precoding) on the data symbols, the control symbols, and/or the reference symbols, if applicable, and may provide output symbol streams to the modulators (MODs) 432a through 432t. For example, the TX MIMO processor 430 may perform certain aspects described herein for RS multiplexing. Each modulator 432 may process a respective output symbol stream (e.g., for OFDM, etc.) to obtain an output sample stream. Each modulator 432 may further process (e.g., convert to analog, amplify, filter, and upconvert) the output sample stream to obtain a downlink signal. Downlink signals from modulators 432a through 432t may be transmitted via the antennas 434a through 434t, respectively.

[0063] At the UE 120, the antennas 452a through 452r may receive the downlink signals from the base station 110 and may provide received signals to the demodulators

(DEMODs) 454a through 454r, respectively. Each demodulator 454 may condition (e.g., filter, amplify, downconvert, and digitize) a respective received signal to obtain input samples. Each demodulator 454 may further process the input samples (e.g., for OFDM, etc.) to obtain received symbols. A MIMO detector 456 may obtain received symbols from all the demodulators 454a through 454r, perform MIMO detection on the received symbols if applicable, and provide detected symbols. For example, MIMO detector 456 may provide detected RS transmitted using techniques described herein. A receive processor 458 may process (e.g., demodulate, deinterleave, and decode) the detected symbols, provide decoded data for the UE 120 to a data sink 460, and provide decoded control information to a controller/processor 480.

[0064] On the uplink, at the UE 120, a transmit processor 464 may receive and process data (e.g., for the Physical Uplink Shared Channel (PUSCH)) from a data source 462 and control information (e.g., for the Physical Uplink Control Channel (PUCCH)) from the controller/processor 480. The transmit processor 464 may also generate reference symbols for a reference signal. The symbols from the transmit processor 464 may be precoded by a TX MIMO processor 466 if applicable, further processed by the demodulators 454a through 454r (e.g., for SC-FDM, etc.), and transmitted to the base station 110. At the BS 110, the uplink signals from the UE 120 may be received by the antennas 434, processed by the modulators 432, detected by a MIMO detector 436 if applicable, and further processed by a receive processor 438 to obtain decoded data and control information sent by the UE 120. The receive processor 438 may provide the decoded data to a data sink 439 and the decoded control information to the controller/processor 440.

[0065] The controllers/processors 440 and 480 may direct the operation at the base station 110 and the UE 120, respectively. The processor 440 and/or other processors and modules at the base station 110 may perform or direct, e.g., the execution of the functional blocks illustrated in FIGs. 8A, 8B, and 9, and/or other processes for the techniques described herein. The processor 480 and/or other processors and modules at the UE 120 may also perform or direct processes for the techniques described herein. The memories 442 and 482 may store data and program codes for the BS 110 and the UE 120, respectively. A scheduler 444 may schedule UEs for data transmission on the downlink and/or uplink.

[0066] FIG. 5 illustrates a diagram 500 showing examples for implementing a communications protocol stack, according to aspects of the present disclosure. The illustrated communications protocol stacks may be implemented by devices operating in a 5G system (e.g., a system that supports uplink-based mobility). Diagram 500 illustrates a communications protocol stack including a Radio Resource Control (RRC) layer 510, a Packet Data Convergence Protocol (PDCP) layer 515, a Radio Link Control (RLC) layer 520, a Medium Access Control (MAC) layer 525, and a Physical (PHY) layer 530. In various examples the layers of a protocol stack may be implemented as separate modules of software, portions of a processor or ASIC, portions of non-collocated devices connected by a communications link, or various combinations thereof. Collocated and non-collocated implementations may be used, for example, in a protocol stack for a network access device (e.g., ANs, CUs, and/or DUs) or a UE.

[0067] A first option 505-a shows a split implementation of a protocol stack, in which implementation of the protocol stack is split between a centralized network access device (e.g., an ANC 202 in FIG. 2) and distributed network access device (e.g., DU 208 in FIG. 2). In the first option 505-a, an RRC layer 510 and a PDCP layer 515 may be implemented by the central unit, and an RLC layer 520, a MAC layer 525, and a PHY layer 530 may be implemented by the DU. In various examples the CU and the DU may be collocated or non-collocated. The first option 505-a may be useful in a macro cell, micro cell, or pico cell deployment.

[0068] A second option 505-b shows a unified implementation of a protocol stack, in which the protocol stack is implemented in a single network access device (e.g., access node (AN), new radio base station (NR BS), a new radio Node-B (NR NB), a network node (NN), or the like.). In the second option, the RRC layer 510, the PDCP layer 515, the RLC layer 520, the MAC layer 525, and the PHY layer 530 may each be implemented by the AN. The second option 505-b may be useful in a femto cell deployment.

[0069] Regardless of whether a network access device implements part or all of a protocol stack, a UE may implement an entire protocol stack (e.g., the RRC layer 510, the PDCP layer 515, the RLC layer 520, the MAC layer 525, and the PHY layer 530).

[0070] FIG. 6 is a diagram 600 showing an example of a DL-centric subframe. The DL-centric subframe may include a control portion 602. The control portion 602 may exist in the initial or beginning portion of the DL-centric subframe. The control portion 602 may include various scheduling information and/or control information corresponding to various portions of the DL-centric subframe. In some configurations, the control portion 602 may be a physical DL control channel (PDCCH), as indicated in FIG. 6. The DL-centric subframe may also include a DL data portion 604. The DL data portion 604 may sometimes be referred to as the payload of the DL-centric subframe. The DL data portion 604 may include the communication resources utilized to communicate DL data from the scheduling entity (e.g., UE or BS) to the subordinate entity (e.g., UE). In some configurations, the DL data portion 604 may be a physical DL shared channel (PDSCH).

[0071] The DL-centric subframe may also include a common UL portion 606. The common UL portion 606 may sometimes be referred to as an UL burst, a common UL burst, and/or various other suitable terms. The common UL portion 606 may include feedback information corresponding to various other portions of the DL-centric subframe. For example, the common UL portion 606 may include feedback information corresponding to the control portion 602. Non-limiting examples of feedback information may include an ACK signal, a NACK signal, a HARQ indicator, and/or various other suitable types of information. The common UL portion 606 may include additional or alternative information, such as information pertaining to random access channel (RACH) procedures, scheduling requests (SRs), and various other suitable types of information. As illustrated in FIG. 6, the end of the DL data portion 604 may be separated in time from the beginning of the common UL portion 606. This time separation may sometimes be referred to as a gap, a guard period, a guard interval, and/or various other suitable terms. This separation provides time for the switch-over from DL communication (e.g., reception operation by the subordinate entity (e.g., UE)) to UL communication (e.g., transmission by the subordinate entity (e.g., UE)). One of ordinary skill in the art will understand that the foregoing is merely one example of a DL-centric subframe and alternative structures having similar features may exist without necessarily deviating from the aspects described herein.

[0072] FIG. 7 is a diagram 700 showing an example of an UL-centric subframe. The UL -centric subframe may include a control portion 702. The control portion 702 may exist in the initial or beginning portion of the UL-centric subframe. The control portion 702 in FIG. 7 may be similar to the control portion described above with reference to FIG. 6. The UL-centric subframe may also include an UL data portion 704. The UL data portion 704 may sometimes be referred to as the payload of the UL-centric subframe. The UL portion may refer to the communication resources utilized to communicate UL data from the subordinate entity (e.g., UE) to the scheduling entity (e.g., UE or BS). In some configurations, the control portion 702 may be a physical DL control channel (PDCCH).

[0073] As illustrated in FIG. 7, the end of the control portion 702 may be separated in time from the beginning of the UL data portion 704. This time separation may sometimes be referred to as a gap, guard period, guard interval, and/or various other suitable terms. This separation provides time for the switch-over from DL communication (e.g., reception operation by the scheduling entity) to UL communication (e.g., transmission by the scheduling entity). The UL-centric subframe may also include a common UL portion 706. The common UL portion 706 in FIG. 7 may be similar to the common UL portion 706 described above with reference to FIG. 7. The common UL portion 706 may additional or alternative include information pertaining to channel quality indicator (CQI), sounding reference signals (SRSs), and various other suitable types of information. One of ordinary skill in the art will understand that the foregoing is merely one example of an UL-centric subframe and alternative structures having similar features may exist without necessarily deviating from the aspects described herein.

[0074] In some circumstances, two or more subordinate entities (e.g., UEs) may communicate with each other using sidelink signals. Real-world applications of such sidelink communications may include public safety, proximity services, UE-to-network relaying, vehicle-to-vehicle (V2V) communications, Internet of Everything (IoE) communications, IoT communications, mission-critical mesh, and/or various other suitable applications. Generally, a sidelink signal may refer to a signal communicated from one subordinate entity (e.g., UE1) to another subordinate entity (e.g., UE2) without relaying that communication through the scheduling entity (e.g., UE or BS),

even though the scheduling entity may be utilized for scheduling and/or control purposes. In some examples, the sidelink signals may be communicated using a licensed spectrum (unlike wireless local area networks, which typically use an unlicensed spectrum).

[0075] A UE may operate in various radio resource configurations, including a configuration associated with transmitting pilots using a dedicated set of resources (e.g., a radio resource control (RRC) dedicated state, etc.) or a configuration associated with transmitting pilots using a common set of resources (e.g., an RRC common state, etc.). When operating in the RRC dedicated state, the UE may select a dedicated set of resources for transmitting a pilot signal to a network. When operating in the RRC common state, the UE may select a common set of resources for transmitting a pilot signal to the network. In either case, a pilot signal transmitted by the UE may be received by one or more network access devices, such as an AN, or a DU, or portions thereof. Each receiving network access device may be configured to receive and measure pilot signals transmitted on the common set of resources, and also receive and measure pilot signals transmitted on dedicated sets of resources allocated to the UEs for which the network access device is a member of a monitoring set of network access devices for the UE. One or more of the receiving network access devices, or a CU to which receiving network access device(s) transmit the measurements of the pilot signals, may use the measurements to identify serving cells for the UEs, or to initiate a change of serving cell for one or more of the UEs.

EXAMPLE TECHNIQUES FOR TRANSMITTING SOUNDING REFERENCE SIGNALS

[0076] In communications systems operating according to LTE standards, a discrete Fourier transform spread orthogonal frequency division multiplexing (DFT-S-OFDM) based waveform is used for transmission of UL physical channels (e.g., PUSCHs) and signals, such as UL demodulation reference signals (DMRS) and sounding reference signals (SRS).

[0077] SRS are transmitted using an interleaved frequency division multiple access (IFDMA) waveform, which is a special DFT-S-OFDM waveform.

[0078] NR supports DFT-S-OFDM based waveform and CP-OFDM waveform for uplink transmissions, at least for eMBB uplink transmissions on bandwidths of up to 40 GHz.

[0079] According to aspects of the present disclosure, a CP-OFDM waveform may be used for uplink single-stream and multi-stream (e.g., MIMO) transmissions.

[0080] While CP-OFDM may be used for all uplink transmissions, in wireless communications systems operating according to NR technologies, a DFT-S-OFDM based waveform may be used for single stream transmissions in which communications from a UE are limited by a link budget for the UE. That is, a UE that is experiencing poor link conditions, for example, due to interference or long distance to a BS, may use DFT-S-OFDM based waveforms for transmitting to the BS to improve the signal strength received by the BS.

[0081] According to aspects of the present disclosure, a network (e.g., a network entity, such as a BS) may decide and communicate to a UE which one of CP-OFDM and DFT-S-OFDM based waveforms the UE should use when transmitting (e.g., transmitting SRS) to the network. In one example, UEs support both CP-OFDM and DFT-S-OFDM based waveforms.

[0082] According to aspects of the present disclosure, SRS transmission using a DFT-S-OFDM based waveform may be less efficient in resource utilization than SRS transmission using a CP-OFDM based waveform. When SRS are transmitted using a DFT-S-OFDM waveform, the whole DFT-S-OFDM symbol has to be reserved for SRS and cannot be multiplexed with PUSCH, in order to preserve the single carrier property of the uplink transmission.

[0083] According to aspects of the present disclosure, when SRS are transmitted using a CP-OFDM waveform, frequency multiplexing of SRS and physical uplink shared channel (PUSCH) is allowed by using a structure similar to a channel state information reference signal (CSI-RS) structure, wherein multiple ports are multiplexed in frequency and/or in code (e.g., FDM and/or CDM) to transmit SRS and a PUSCH may be mapped to resource elements (REs) that are not occupied by the SRS.

[0084] In aspects of the present disclosure, a CP-OFDM waveform may allow a UE to use subband precoding in an SRS transmission. DCI signals may be used to allocate

resources to the UE. For example, a DCI may be used by the UE to schedule DL resources on the PDSCH and UL resources on the PUSCH. In one example, subband-wise precoded SRS may be used for frequency-selective precoding in UL with a small amount of overhead in DCIs. The small amount of overhead in DCIs may include a few (e.g., two) bits in UL grants (e.g., in the DCIs granting the UL grants) to indicate which precoded SRS ports a UE should use in transmitting the subband-wise precoded SRS. The network may configure a UE to transmit SRS using one of a CP-OFDM and a DFT-S-OFDM based waveform.

[0085] FIG. 8A illustrates example operations 800 for wireless communications, according to aspects of the present disclosure. Operations 800 may be performed by a UE, for example, UE 120, shown in FIG. 1.

[0086] Operations 800 begin, at block 802, with the UE determining whether to transmit a sounding reference signal (SRS) using a discrete Fourier transform (DFT) spread orthogonal frequency domain multiplexing (DFT-S-OFDM) waveform or a cyclic prefix orthogonal frequency domain multiplexing (CP-OFDM) waveform. For example, UE 120, shown in FIG. 1, may determine to transmit an SRS using a DFT-S-OFDM waveform.

[0087] At block 804, operations 800 continue with the UE transmitting the SRS using the determined waveform. Continuing the example from above, the UE 120 may transmit an SRS using a DFT-S-OFDM waveform.

[0088] FIG. 8B illustrates example operations 805 for wireless communications, according to aspects of the present disclosure. Operations 805 may be performed by a UE, for example, UE 120, shown in FIG. 1.

[0089] Operations 805 begin, at block 806, with the UE receiving an indication of whether to transmit a sounding reference signal (SRS) using a discrete Fourier transform (DFT) spread orthogonal frequency domain multiplexing (DFT-S-OFDM) waveform or a cyclic prefix orthogonal frequency domain multiplexing (CP-OFDM) waveform. For example, UE 120, shown in FIG. 1, receives an indication to transmit an SRS using a DFT-S-OFDM waveform.

[0090] At block 808, operations 805 continue with the UE transmitting the SRS using the determined waveform. Continuing the example from above, the UE 120 transmits an SRS using a DFT-S-OFDM waveform.

[0091] FIG. 9 illustrates example operations 900 for wireless communications, in accordance with aspects of the present disclosure. Operations 900 may be performed by a BS, for example, BS 110, shown in FIG. 1. Operations 900 may be complementary to operations 805, described above with reference to FIG. 8B.

[0092] Operations 900 begin, at block 902, with the BS determining whether a user equipment (UE) is to transmit a sounding reference signal (SRS) using a discrete Fourier transform (DFT) spread orthogonal frequency domain multiplexing (DFT-S-OFDM) waveform or a cyclic prefix orthogonal frequency domain multiplexing (CP-OFDM) waveform. For example, BS 110, shown in FIG. 1, determines that UE 120 is to transmit an SRS using a DFT-S-OFDM waveform.

[0093] At block 904, operations 900 continue with the BS sending an indication of the determined waveform to the UE. Continuing the example from above, BS 110 sends an indication of the DFT-S-OFDM waveform to UE 120.

[0094] Operations 900 continue at block 906 with the BS processing the SRS, based on the determined waveform. Still in the example from above, BS 110 processes the SRS based on the DFT-S-OFDM waveform (determined in block 902).

[0095] Different SRS waveforms can be multiplexed in frequency in one RB. According to aspects of the present disclosure, a UE can be configured with (e.g., programmed to transmit) one or more waveforms for SRS transmission. At least one of the one or more waveforms is a DFT-S-OFDM based waveform (e.g., similar to the SRS waveform used by UEs operating in an LTE system). Another waveform may be a CP-OFDM waveform (e.g., similar to DL DMRS waveform used by BSs in an LTE system).

[0096] FIG. 10 illustrates a technique 1000 for multiplexing SRSs using different waveforms in frequency. The SRS may have a comb structure in the frequency domain, and a UE may transmit the SRS on one of the combs. As illustrated in frequency bands 1010 and 1020, UEs 1 and 2 (e.g., two of the UEs 120 shown in FIG. 1) may use DFT-S-OFDM based waveform(s) to transmit their SRSs on combs 0 and 1 of a bandwidth,

respectfully. The various SRS ports for each of the UEs 1 and 2 may be multiplexed on a same comb for each UE by using different cyclic shifts for each of the SRS ports. UE 3 (e.g., another UE 120 shown in FIG. 1) may use a CP-OFDM based waveform to transmit SRS on combs 2 and 3, as illustrated in frequency band 1030. Two SRS ports may be multiplexed in frequency domain using a size-2 orthogonal cover code.

[0097] FIG. 11 illustrates a technique 1100 for transmitting an SRS, in accordance with aspects of the present disclosure. The waveform selected may depend on other UL physical channels/signals. The waveform for SRS transmission, by a UE, in a slot and/or bandwidth part (i.e., a partial band) may be associated with the waveform used for the transmission of UL physical channels and/or signals by the UE in the same slot and/or bandwidth part. For example, if a UE is configured and/or indicated to transmit a PUSCH 1112 using a DFT-S-OFDM based waveform in a slot and/or bandwidth part, the UE uses a DFT-S-OFDM based waveform to transmit an SRS 1114 in the same slot and/or bandwidth part, as illustrated at 1110. In another example, if a UE is configured and/or indicated to transmit a PUSCH 1122 using a CP-OFDM waveform in a slot and/or bandwidth part, the UE uses a CP-OFDM waveform to transmit an SRS 1124 in the same slot and/or bandwidth part, as illustrated at 1120.

[0098] In aspects of the present disclosure, the waveform for SRS transmission by a UE in a slot and/or bandwidth part (i.e., a partial band) may be associated with the number of ports to be sounded in that slot and/or bandwidth part. For example, if a UE is configured and/or indicated to transmit a single port SRS, the UE may use a DFT-S-OFDM based waveform, while if the UE is configured and/or indicated to transmit SRS using two or more antenna ports, the UE may use a CP-OFDM waveform.

[0099] According to aspects of the present disclosure, if a UE is configured and/or indicated to transmit an N-port SRS, the UE may determine to use a DFT-S-OFDM based waveform when $N < X$, or a CP-OFDM waveform shall be used when $N \geq X$. The UE may be configured with a value of X via a signal (e.g., RRC signaling) and/or via a field in the signal triggering the UE to transmit the N-port SRS.

[0100] FIG. 12 illustrates a technique 1200 for determining a waveform for transmitting an SRS, in accordance with aspects of the present disclosure. The waveform for SRS transmission may be determined based on whether the SRS is transmitted on a single or multiple component carriers (CCs). For non-simultaneous

sounding, e.g., an SRS is to be transmitted on only one CC in a slot, one of CP-OFDM and DFT-S-FDMA based waveforms can be used for one CC, and different waveforms can be configured for different CCs. For example, a CP-OFDM waveform may be used for SRS transmission on one CC, as shown at 1210, and a DFT-S-OFDM waveform may be used on another CC, as shown at 1220.

[0101] FIG. 13 illustrates a technique 1300 for determining a waveform for transmitting an SRS, in accordance with aspects of the present disclosure. For simultaneous sounding, e.g., an SRS is to be transmitted on multiple CCs in a slot, a DFT-S-OFDM based waveform may be used for SRS transmission on multiple CCs, as shown at 1310.

[0102] According to aspects of the present disclosure, a UE may determine a waveform to use in transmitting an SRS based on a number of CCs, N , associated with a single RF chain of the UE. For example, the UE may use a DFT-S-OFDM based waveform to transmit the SRS if $N < X$; otherwise, the UE may use a CP-OFDM waveform. The value of X may be determined by the UE according to a networking standard and/or configured by the network (e.g., send to the UE in an RRC signal from a BS).

[0103] In aspects of the present disclosure, a UE may be configured to use different waveforms for SRS transmission on different subband sets (i.e., bandwidth parts or partial bands). For example, when a UE is configured with two bandwidth parts, the UE may transmit SRS on one bandwidth part using a DFT-S-OFDM based waveform, and on another bandwidth part using a CP-OFDM waveform.

[0104] FIG. 14 illustrates a technique 1400 for determining a waveform for transmitting an SRS, in accordance with aspects of the present disclosure. In aspects of the present disclosure, a UE may be configured with different waveforms for SRS transmission on different slot sets (e.g., subframe sets). For example, a UE may be configured with two slot sets, 1410 and 1420. In the example, the UE may transmit an SRS using a DFT-S-OFDM based waveform in slots in the 1st slot set 1410, and using a CP-OFDM waveform in slots in the 2nd slot set 1420.

[0105] According to aspects of the present disclosure, a UE may determine a waveform for SRS transmission based on a configuration that is independent from other

UL physical channels or signals via L1, L2, and/or higher-layer signaling. On receiving the signaling, the UE may start to use the indicated waveform for SRS transmission in a next SRS transmission instance. For example, a waveform to be used for an SRS can be dynamically indicated by L1 signaling (e.g., one or more bits in a DCI may indicate one of the configured waveforms to a UE). In another example, the waveform to use for SRS may be semi-persistently configured by L1 signaling (e.g., in DCI) or L2 signaling (e.g., in a medium access control (MAC) control element (CE)). In yet another example, the waveform can be semi-statically indicated and/or configured by higher-layer signaling (e.g., RRC signaling).

[0106] In aspects of the present disclosure, the transmit power for SRS can be either waveform dependent or waveform independent. That is, a UE may determine transmit power for an SRS to be transmitted using a same set of open-loop power control (OLPC) parameters or separate OLPC parameters for CP-OFDM waveform SRS and DFT-S-OFDM waveform SRS. The OLPC parameters may include a UE transmit power (P_{CMAX}), an SRS power offset ($P_{\text{SRS_OFFSET}}$), and a path loss compensation component (α).

[0107] If the UE determines transmit power for an SRS independent of the type of waveform to be used for that SRS, then the UE may configure one set of OLPC parameters for SRS regardless of whether CP-OFDM or DFT-S-OFDM based waveform is used.

[0108] If the UE determines transmit power for an SRS depending on the type of waveform to be used for that SRS, then the UE may configure two sets of OLPC parameters, with a first set for use when the UE is transmitting SRS using a DFT-S-OFDM waveform and a second set for use when the UE is transmitting SRS using a CP-OFDM waveform.

[0109] Similarly to the OLPC parameters discussed above, a UE may be configured to use a same or separate close-loop power control (CLPC) processes and commands for transmitting SRS. Each type of waveform (e.g., CP-OFDM and DFT-S-OFDM) may have its own power control adjustment state. A transmit power control (TPC) command received from a BS may be explicitly associated with a waveform. For example, CRC parity bits in a transmission from a BS may be scrambled with one of two radio network temporary identifiers (RNTIs) for TPC, with one RNTI used to indicate the TPC is

intended for SRS using CP-OFDM waveform and the other RNTI used to indicate the TPC is intended for SRS using a DFT-S-OFDM waveform. A TPC command may be implicitly associated with a waveform. For example, if a TPC is issued in an UL-centric slot and a PUSCH is scheduled for the UE, the UE may assume that it's for the SRS using the waveform as same as that for the PUSCH transmission.

[0110] The methods disclosed herein comprise one or more steps or actions for achieving the described method. The method steps and/or actions may be interchanged with one another without departing from the scope of the claims. In other words, unless a specific order of steps or actions is specified, the order and/or use of specific steps and/or actions may be modified without departing from the scope of the claims.

[0111] As used herein, a phrase referring to "at least one of" a list of items refers to any combination of those items, including single members. As an example, "at least one of: a, b, or c" is intended to cover a, b, c, a-b, a-c, b-c, and a-b-c, as well as any combination with multiples of the same element (e.g., a-a, a-a-a, a-a-b, a-a-c, a-b-b, a-c-c, b-b, b-b-b, b-b-c, c-c, and c-c-c or any other ordering of a, b, and c).

[0112] As used herein, the term "determining" encompasses a wide variety of actions. For example, "determining" may include calculating, computing, processing, deriving, investigating, looking up (e.g., looking up in a table, a database or another data structure), ascertaining and the like. Also, "determining" may include receiving (e.g., receiving information), accessing (e.g., accessing data in a memory) and the like. Also, "determining" may include resolving, selecting, choosing, establishing and the like.

[0113] The previous description is provided to enable any person skilled in the art to practice the various aspects described herein. Various modifications to these aspects will be readily apparent to those skilled in the art, and the generic principles defined herein may be applied to other aspects. Thus, the claims are not intended to be limited to the aspects shown herein, but is to be accorded the full scope consistent with the language claims, wherein reference to an element in the singular is not intended to mean "one and only one" unless specifically so stated, but rather "one or more." Unless specifically stated otherwise, the term "some" refers to one or more. All structural and functional equivalents to the elements of the various aspects described throughout this disclosure that are known or later come to be known to those of ordinary skill in the art

are expressly incorporated herein by reference and are intended to be encompassed by the claims. Moreover, nothing disclosed herein is intended to be dedicated to the public regardless of whether such disclosure is explicitly recited in the claims. No claim element is to be construed under the provisions of 35 U.S.C. §112, sixth paragraph, unless the element is expressly recited using the phrase “means for” or, in the case of a method claim, the element is recited using the phrase “step for.”

[0114] The various operations of methods described above may be performed by any suitable means capable of performing the corresponding functions. The means may include various hardware and/or software component(s) and/or module(s), including, but not limited to a circuit, an application specific integrated circuit (ASIC), or processor. Generally, where there are operations illustrated in figures, those operations may have corresponding counterpart means-plus-function components with similar numbering.

[0115] For example, means for transmitting, means for sending, and/or means for receiving may comprise one or more of a transmit processor 420, a TX MIMO processor 430, a receive processor 438, or antenna(s) 434 of the base station 110 and/or the transmit processor 464, a TX MIMO processor 466, a receive processor 458, or antenna(s) 452 of the user equipment 120. Additionally, means for generating, means for multiplexing, means for determining, means for processing, and/or means for applying may comprise one or more processors, such as the controller/processor 440 of the base station 110 and/or the controller/processor 480 of the user equipment 120.

[0116] The various illustrative logical blocks, modules and circuits described in connection with the present disclosure may be implemented or performed with a general purpose processor, a digital signal processor (DSP), an application specific integrated circuit (ASIC), a field programmable gate array (FPGA) or other programmable logic device (PLD), discrete gate or transistor logic, discrete hardware components, or any combination thereof designed to perform the functions described herein. A general-purpose processor may be a microprocessor, but in the alternative, the processor may be any commercially available processor, controller, microcontroller, or state machine. A processor may also be implemented as a combination of computing devices, e.g., a combination of a DSP and a microprocessor, a plurality of microprocessors, one or more microprocessors in conjunction with a DSP core, or any other such configuration.

[0117] If implemented in hardware, an example hardware configuration may comprise a processing system in a wireless node. The processing system may be implemented with a bus architecture. The bus may include any number of interconnecting buses and bridges depending on the specific application of the processing system and the overall design constraints. The bus may link together various circuits including a processor, machine-readable media, and a bus interface. The bus interface may be used to connect a network adapter, among other things, to the processing system via the bus. The network adapter may be used to implement the signal processing functions of the PHY layer. In the case of a user terminal 120 (see FIG. 1), a user interface (e.g., keypad, display, mouse, joystick, etc.) may also be connected to the bus. The bus may also link various other circuits such as timing sources, peripherals, voltage regulators, power management circuits, and the like, which are well known in the art, and therefore, will not be described any further. The processor may be implemented with one or more general-purpose and/or special-purpose processors. Examples include microprocessors, microcontrollers, DSP processors, and other circuitry that can execute software. Those skilled in the art will recognize how best to implement the described functionality for the processing system depending on the particular application and the overall design constraints imposed on the overall system.

[0118] If implemented in software, the functions may be stored or transmitted over as one or more instructions or code on a computer readable medium. Software shall be construed broadly to mean instructions, data, or any combination thereof, whether referred to as software, firmware, middleware, microcode, hardware description language, or otherwise. Computer-readable media include both computer storage media and communication media including any medium that facilitates transfer of a computer program from one place to another. The processor may be responsible for managing the bus and general processing, including the execution of software modules stored on the machine-readable storage media. A computer-readable storage medium may be coupled to a processor such that the processor can read information from, and write information to, the storage medium. In the alternative, the storage medium may be integral to the processor. By way of example, the machine-readable media may include a transmission line, a carrier wave modulated by data, and/or a computer readable storage medium with instructions stored thereon separate from the wireless node, all of which may be

accessed by the processor through the bus interface. Alternatively, or in addition, the machine-readable media, or any portion thereof, may be integrated into the processor, such as the case may be with cache and/or general register files. Examples of machine-readable storage media may include, by way of example, RAM (Random Access Memory), flash memory, ROM (Read Only Memory), PROM (Programmable Read-Only Memory), EPROM (Erasable Programmable Read-Only Memory), EEPROM (Electrically Erasable Programmable Read-Only Memory), registers, magnetic disks, optical disks, hard drives, or any other suitable storage medium, or any combination thereof. The machine-readable media may be embodied in a computer-program product.

[0119] A software module may comprise a single instruction, or many instructions, and may be distributed over several different code segments, among different programs, and across multiple storage media. The computer-readable media may comprise a number of software modules. The software modules include instructions that, when executed by an apparatus such as a processor, cause the processing system to perform various functions. The software modules may include a transmission module and a receiving module. Each software module may reside in a single storage device or be distributed across multiple storage devices. By way of example, a software module may be loaded into RAM from a hard drive when a triggering event occurs. During execution of the software module, the processor may load some of the instructions into cache to increase access speed. One or more cache lines may then be loaded into a general register file for execution by the processor. When referring to the functionality of a software module below, it will be understood that such functionality is implemented by the processor when executing instructions from that software module.

[0120] Also, any connection is properly termed a computer-readable medium. For example, if the software is transmitted from a website, server, or other remote source using a coaxial cable, fiber optic cable, twisted pair, digital subscriber line (DSL), or wireless technologies such as infrared (IR), radio, and microwave, then the coaxial cable, fiber optic cable, twisted pair, DSL, or wireless technologies such as infrared, radio, and microwave are included in the definition of medium. Disk and disc, as used herein, include compact disc (CD), laser disc, optical disc, digital versatile disc (DVD), floppy disk, and Blu-ray® disc where disks usually reproduce data magnetically, while discs reproduce data optically with lasers. Thus, in some aspects computer-readable

media may comprise non-transitory computer-readable media (e.g., tangible media). In addition, for other aspects computer-readable media may comprise transitory computer-readable media (e.g., a signal). Combinations of the above should also be included within the scope of computer-readable media.

[0121] Thus, certain aspects may comprise a computer program product for performing the operations presented herein. For example, such a computer program product may comprise a computer-readable medium having instructions stored (and/or encoded) thereon, the instructions being executable by one or more processors to perform the operations described herein. For example, instructions for perform the operations described herein and illustrated in FIGs. 13, 17, and 18.

[0122] Further, it should be appreciated that modules and/or other appropriate means for performing the methods and techniques described herein can be downloaded and/or otherwise obtained by a user terminal and/or base station as applicable. For example, such a device can be coupled to a server to facilitate the transfer of means for performing the methods described herein. Alternatively, various methods described herein can be provided via storage means (e.g., RAM, ROM, a physical storage medium such as a compact disc (CD) or floppy disk, etc.), such that a user terminal and/or base station can obtain the various methods upon coupling or providing the storage means to the device. Moreover, any other suitable technique for providing the methods and techniques described herein to a device can be utilized.

[0123] It is to be understood that the claims are not limited to the precise configuration and components illustrated above. Various modifications, changes and variations may be made in the arrangement, operation and details of the methods and apparatus described above without departing from the scope of the claims.

CLAIMS

WHAT IS CLAIMED IS:

1. A method for wireless communications by a user equipment (UE), comprising:
determining whether to transmit a sounding reference signal (SRS) using a discrete Fourier transform (DFT) spread orthogonal frequency domain multiplexing (DFT-S-OFDM) waveform or a cyclic prefix orthogonal frequency domain multiplexing (CP-OFDM) waveform; and
transmitting the SRS using the determined waveform.
2. The method of claim 1, wherein the determination comprises determining to use a same waveform used for an uplink transmission by the UE in a same slot or a same bandwidth part as the SRS.
3. The method of claim 1, wherein the determination comprises determining whether to transmit the SRS using the DFT-S-OFDM waveform or the CP-OFDM waveform based on a number of antenna ports used in transmitting the SRS.
4. The method of claim 3, wherein the determination comprises:
determining to use the DFT-S-OFDM waveform if the number of antenna ports is lower than a threshold; and
determining to use the CP-OFDM waveform if the number of antenna ports is greater than or equal to the threshold.
5. The method of claim 1, wherein the determination comprises determining whether to transmit the SRS using the DFT-S-OFDM waveform or the CP-OFDM waveform based on a component carrier (CC) or a bandwidth part used to transmit the SRS.
6. The method of claim 1, wherein the determination comprises determining whether to transmit the SRS using the DFT-S-OFDM waveform or the CP-OFDM

waveform based on a number of component carriers (CCs) or bandwidth parts used to transmit the SRS.

7. The method of claim 6, wherein the DFT-S-OFDM waveform or the CP-OFDM waveform is configured for physical uplink shared channels (PUSCHs) in each CC and the determination comprises determining to transmit the SRS using the DFT-S-OFDM waveform.

8. The method of claim 6, wherein the determination comprises determining whether to transmit the SRS using the DFT-S-OFDM waveform or the CP-OFDM waveform based on a number of CCs in a same frequency band.

9. The method of claim 8, wherein the determination comprises:
determining to use the DFT-S-OFDM waveform if the number of CCs in the same frequency band is less than a threshold; and
determining to use the CP-OFDM waveform if the number of CCs in the same band is greater than or equal to the threshold.

10. The method of claim 6, wherein the DFT-S-OFDM waveform or the CP-OFDM waveform is configured for physical uplink shared channels (PUSCHs) in each bandwidth part and the determination comprises determining to transmit the SRS using the DFT-S-OFDM waveform.

11. The method of claim 6, wherein the determination comprises determining whether to transmit the SRS using the DFT-S-OFDM waveform or the CP-OFDM waveform based on a number of bandwidth parts in a same frequency band.

12. The method of claim 1, wherein the UE is configured with one or more bandwidth parts within a system bandwidth and the determination comprises determining whether to transmit the SRS using the DFT-S-OFDM waveform or the CP-OFDM waveform based on a bandwidth part used to transmit the SRS.

13. The method of claim 1, wherein the determination comprises determining whether to transmit the SRS using the DFT-S-OFDM waveform or the CP-OFDM waveform based on a slot in which the SRS is to be transmitted.

14. The method of claim 1, wherein the determination comprises determining whether to transmit the SRS using the DFT-S-OFDM waveform or the CP-OFDM waveform based on an indication received from a base station (BS).

15. The method of claim 14, further comprising:
receiving the indication via layer one (L1) signaling.

16. The method of claim 14, wherein the indication comprises a semi-persistent configuration and the method further comprises:

receiving the semi-persistent configuration via at least one of layer one (L1) signaling, layer 2 (L2) signaling, or radio resource control (RRC) signaling.

17. The method of claim 1, further comprising:

determining, based on a set of open-loop power control (OLPC) parameters, a transmit power, wherein transmitting the SRS comprises transmitting the SRS at the determined transmit power.

18. The method of claim 17, further comprising:

configuring a first set of OLPC parameters for use with DFT-S-OFDM waveform SRS;

configuring a second set of OLPC parameters for use with CP-OFDM waveform SRS; and

determining to use the first set of OLPC parameters or the second set of OLPC parameters based on the determined waveform.

19. The method of claim 1, further comprising:

determining, based on a received closed-loop power control (CLPC) command, a transmit power, wherein transmitting the SRS comprises transmitting the SRS at the determined transmit power.

20. The method of claim 19, further comprising:

receiving the CLPC command;

maintaining a power control adjustment state for DFT-S-OFDM waveform SRS and another power control adjustment state for CP-OFDM waveform SRS;

determining whether to apply the CLPC command to the DFT-S-OFDM waveform SRS power control adjustment state or to the CP-OFDM waveform SRS power control adjustment state; and

applying the CLPC command to the determined power control adjustment state, wherein determining the transmit power comprises determining the transmit power based on a corresponding power control adjustment state.

21. A method for wireless communications by a base station (BS), comprising:

determining whether a user equipment (UE) is to transmit a sounding reference signal (SRS) using a discrete Fourier transform (DFT) spread orthogonal frequency domain multiplexing (DFT-S-OFDM) waveform or a cyclic prefix orthogonal frequency domain multiplexing (CP-OFDM) waveform;

sending an indication of the determined waveform to the UE; and

processing the SRS, based on the determined waveform.

22. The method of claim 21, wherein sending the indication of the determined waveform comprises sending an indication of a same waveform to be used for an uplink transmission by the UE in a same slot or a same bandwidth part as the SRS.

23. The method of claim 21, wherein sending the indication of the determined waveform comprises sending an indication of a number of antenna ports to be used by the UE in transmitting the SRS.

24. The method of claim 23, wherein sending the indication of the determined waveform comprises:

 sending an indication that the UE is to use the DFT-S-OFDM waveform if the number of antenna ports is lower than a threshold; and

 sending an indication that the UE is to use the CP-OFDM waveform if the number of antenna ports is greater than or equal to the threshold.

25. The method of claim 24, further comprising:

 sending an indication of the threshold to the UE.

26. The method of claim 21, wherein sending the indication of the determined waveform comprises sending a component carrier (CC) or a bandwidth part used to transmit the SRS.

27. The method of claim 21, wherein sending the indication of the determined waveform comprises sending a number of component carriers (CCs) or bandwidth parts used to transmit the SRS.

28. The method of claim 21, wherein the UE is configured with one or more bandwidth parts within a system bandwidth and sending the indication of the determined waveform comprises indicating a bandwidth part to be used to transmit the SRS.

29. The method of claim 21, wherein sending the indication of the determined waveform comprises indicating a slot in which the UE is to transmit the SRS.

30. The method of claim 21, wherein sending the indication of the determined waveform comprises sending the indication via layer one (L1) signaling.

31. The method of claim 21, wherein sending the indication comprises sending a semi-persistent configuration via at least one of layer one (L1), layer 2 (L2) signaling, or radio resource control (RRC) signaling.

32. The method of claim 21, further comprising:

 sending an indication to adjust a transmit power of the SRS of the determined waveform, wherein processing the SRS is based on the transmit power of the SRS.

33. The method of claim 32, further comprising:

 determining to send the indication to adjust the transmit power of the SRS based on a previously received SRS of the determined waveform.

34. The method of claim 21, further comprising:

 sending a closed-loop power control (CLPC) command for SRS to the UE, based on the processing of the SRS.

35. The method of claim 34, further comprising:

 maintaining a power control adjustment state for DFT-S-OFDM waveform SRS for the UE and another power control adjustment state for CP-OFDM waveform SRS for the UE, wherein the CLPC command indicates whether the CLPC command should be applied to DFT-S-OFDM waveform SRS or CP-OFDM waveform SRS;

 determining whether the CLPC command should apply to the DFT-S-OFDM waveform SRS power control adjustment state or to the CP-OFDM waveform SRS power control adjustment state; and

 sending an indication of the determined power control adjustment state to which the CLPC command applies.

36. An apparatus for wireless communications, comprising:

 a processor configured to:

 determine whether to transmit a sounding reference signal (SRS) using a discrete Fourier transform (DFT) spread orthogonal frequency domain

multiplexing (DFT-S-OFDM) waveform or a cyclic prefix orthogonal frequency domain multiplexing (CP-OFDM) waveform; and

cause the apparatus to transmit the SRS using the determined waveform;

and

a memory coupled with the processor.

37. The apparatus of claim 36, wherein the processor is configured to determine whether to transmit the SRS using the DFT-S-OFDM waveform or the CP-OFDM waveform by determining to use a same waveform used for an uplink transmission by the apparatus in a same slot or a same bandwidth part as the SRS.

38. The apparatus of claim 36, wherein the processor is configured to determine whether to transmit the SRS using the DFT-S-OFDM waveform or the CP-OFDM waveform based on a number of antenna ports used in transmitting the SRS.

39. The apparatus of claim 38, wherein the processor is configured to:

determine to use the DFT-S-OFDM waveform if the number of antenna ports is lower than a threshold; and

determine to use the CP-OFDM waveform if the number of antenna ports is greater than or equal to the threshold.

40. The apparatus of claim 36, wherein the processor is configured to determine whether to transmit the SRS using the DFT-S-OFDM waveform or the CP-OFDM waveform based on a component carrier (CC) or a bandwidth part used to transmit the SRS.

41. The apparatus of claim 36, wherein the processor is configured to determine whether to transmit the SRS using the DFT-S-OFDM waveform or the CP-OFDM waveform by determining whether to transmit the SRS using the DFT-S-OFDM waveform or the CP-OFDM waveform based on a number of component carriers (CCs) or bandwidth parts used to transmit the SRS.

42. The apparatus of claim 41, wherein the processor is further configured to:
cause the apparatus to transmit physical uplink shared channels (PUSCHs) in each CC using the DFT-S-OFDM waveform or the CP-OFDM waveform; and
determine to transmit the SRS using the DFT-S-OFDM waveform.

43. The method of claim 41, wherein the processor is further configured to determine whether to transmit the SRS using the DFT-S-OFDM waveform or the CP-OFDM waveform by determining whether to transmit the SRS using the DFT-S-OFDM waveform or the CP-OFDM waveform based on a number of CCs in a same frequency band.

44. The apparatus of claim 43, wherein the processor is further configured to determine whether to transmit the SRS using the DFT-S-OFDM waveform or the CP-OFDM waveform by:

determining to use the DFT-S-OFDM waveform if the number of CCs in the same frequency band is less than a threshold; and

determining to use the CP-OFDM waveform if the number of CCs in the same band is greater than or equal to the threshold.

45. The apparatus of claim 41, wherein the processor is further configured to:
cause the apparatus to transmit physical uplink shared channels (PUSCHs) in each bandwidth part using the DFT-S-OFDM waveform or the CP-OFDM waveform;
and

determine to transmit the SRS using the DFT-S-OFDM waveform.

46. The apparatus of claim 41, wherein the processor is configured to determine whether to transmit the SRS using the DFT-S-OFDM waveform or the CP-OFDM waveform based on a number of bandwidth parts in a same frequency band.

47. The apparatus of claim 36, wherein the apparatus is configured with one or more bandwidth parts within a system bandwidth and the processor is configured to determine whether to transmit the SRS using the DFT-S-OFDM waveform or the CP-OFDM waveform based on a bandwidth part used to transmit the SRS.

48. The apparatus of claim 36, wherein the processor is configured to determine whether to transmit the SRS using the DFT-S-OFDM waveform or the CP-OFDM waveform based on a slot in which the SRS is to be transmitted.

49. The apparatus of claim 36, wherein the processor is configured to determine whether to transmit the SRS using the DFT-S-OFDM waveform or the CP-OFDM waveform based on an indication received from a base station (BS).

50. The apparatus of claim 49, wherein the processor is further configured to:
cause the apparatus to receive the indication via layer one (L1) signaling.

51. The apparatus of claim 49, wherein the indication comprises a semi-persistent configuration and the processor is further configured to:

cause the apparatus to receive the semi-persistent configuration via at least one of layer one (L1) signaling, layer 2 (L2) signaling, or radio resource control (RRC) signaling.

52. The apparatus of claim 36, wherein the processor is further configured to:
determine, based on a set of open-loop power control (OLPC) parameters, a transmit power; and

cause the apparatus to transmit the SRS at the determined transmit power.

53. The apparatus of claim 52, wherein the processor is further configured to:
configure a first set of OLPC parameters for use with DFT-S-OFDM waveform SRS;

configure a second set of OLPC parameters for use with CP-OFDM waveform SRS; and

determine to use the first set of OLPC parameters or the second set of OLPC parameters based on the determined waveform.

54. The apparatus of claim 36, wherein the processor is further configured to:
determine, based on a received closed-loop power control (CLPC) command, a transmit power; and
cause the apparatus to transmit the SRS at the determined transmit power.

55. The apparatus of claim 54, wherein the processor is further configured to:
cause the apparatus to receive the CLPC command;
maintain a power control adjustment state for DFT-S-OFDM waveform SRS and another power control adjustment state for CP-OFDM waveform SRS;
determine whether to apply the CLPC command to the DFT-S-OFDM waveform SRS power control adjustment state or to the CP-OFDM waveform SRS power control adjustment state;
apply the CLPC command to the determined power control adjustment state; and
cause the apparatus to transmit the SRS based on a corresponding power control adjustment state.

56. An apparatus for wireless communications, comprising:
a processor configured to:
determine whether a user equipment (UE) is to transmit a sounding reference signal (SRS) using a discrete Fourier transform (DFT) spread orthogonal frequency domain multiplexing (DFT-S-OFDM) waveform or a cyclic prefix orthogonal frequency domain multiplexing (CP-OFDM) waveform;
cause the apparatus to send an indication of the determined waveform to the UE; and
process the SRS, based on the determined waveform; and
a memory coupled with the processor.

57. The apparatus of claim 56, wherein the processor is configured to cause the apparatus to send the indication of the determined waveform by causing the apparatus to send an indication of a same waveform to be used for an uplink transmission by the UE in a same slot or a same bandwidth part as the SRS.

58. The apparatus of claim 56, wherein the processor is configured to cause the apparatus to send the indication of the determined waveform by causing the apparatus to send an indication of a number of antenna ports to be used by the UE in transmitting the SRS.

59. The apparatus of claim 58, wherein the processor is configured to cause the apparatus to send the indication of the determined waveform by:

causing the apparatus to send an indication that the UE is to use the DFT-S-OFDM waveform if the number of antenna ports is lower than a threshold; and

causing the apparatus to send an indication that the UE is to use the CP-OFDM waveform if the number of antenna ports is greater than or equal to the threshold.

60. The apparatus of claim 59, wherein the processor is further configured to: cause the apparatus to send an indication of the threshold to the UE.

61. The apparatus of claim 56, wherein the processor is configured to cause the apparatus to send the indication of the determined waveform by causing the apparatus to send a component carrier (CC) or a bandwidth part used to transmit the SRS.

62. The apparatus of claim 56, wherein the processor is configured to cause the apparatus to send the indication of the determined waveform by causing the apparatus to send a number of component carriers (CCs) or bandwidth parts used to transmit the SRS.

63. The apparatus of claim 56, wherein the UE is configured with one or more bandwidth parts within a system bandwidth and the processor is configured to cause the apparatus to send the indication of the determined waveform by causing the apparatus to send an indication of a bandwidth part to be used to transmit the SRS.

64. The apparatus of claim 56, wherein the processor is configured to cause the apparatus to send the indication of the determined waveform by causing the apparatus to send an indication of a slot in which the UE is to transmit the SRS.

65. The apparatus of claim 56, wherein the processor is configured to cause the apparatus to send the indication of the determined waveform by causing the apparatus to send the indication via layer one (L1) signaling.

66. The apparatus of claim 56, wherein the processor is configured to cause the apparatus to send the indication by sending a semi-persistent configuration via at least one of layer one (L1), layer 2 (L2) signaling, or radio resource control (RRC) signaling.

67. The apparatus of claim 56, wherein the processor is further configured to:
cause the apparatus to send an indication to adjust a transmit power of the SRS of the determined waveform; and
process the SRS based on the transmit power of the SRS.

68. The apparatus of claim 67, wherein the processor is further configured to:
determine to cause the apparatus to send the indication to adjust the transmit power of the SRS based on a previously received SRS of the determined waveform.

69. The apparatus of claim 56, wherein the processor is further configured to:
cause the apparatus to send a closed-loop power control (CLPC) command for SRS to the UE, based on the processing of the SRS.

70. The method of claim 69, wherein the processor is further configured to:

maintain a power control adjustment state for DFT-S-OFDM waveform SRS for the UE and another power control adjustment state for CP-OFDM waveform SRS for the UE, wherein the CLPC command indicates whether the CLPC command should be applied to DFT-S-OFDM waveform SRS or CP-OFDM waveform SRS;

determine whether the CLPC command should apply to the DFT-S-OFDM waveform SRS power control adjustment state or to the CP-OFDM waveform SRS power control adjustment state; and

cause the apparatus to send an indication of the determined power control adjustment state to which the CLPC command applies.

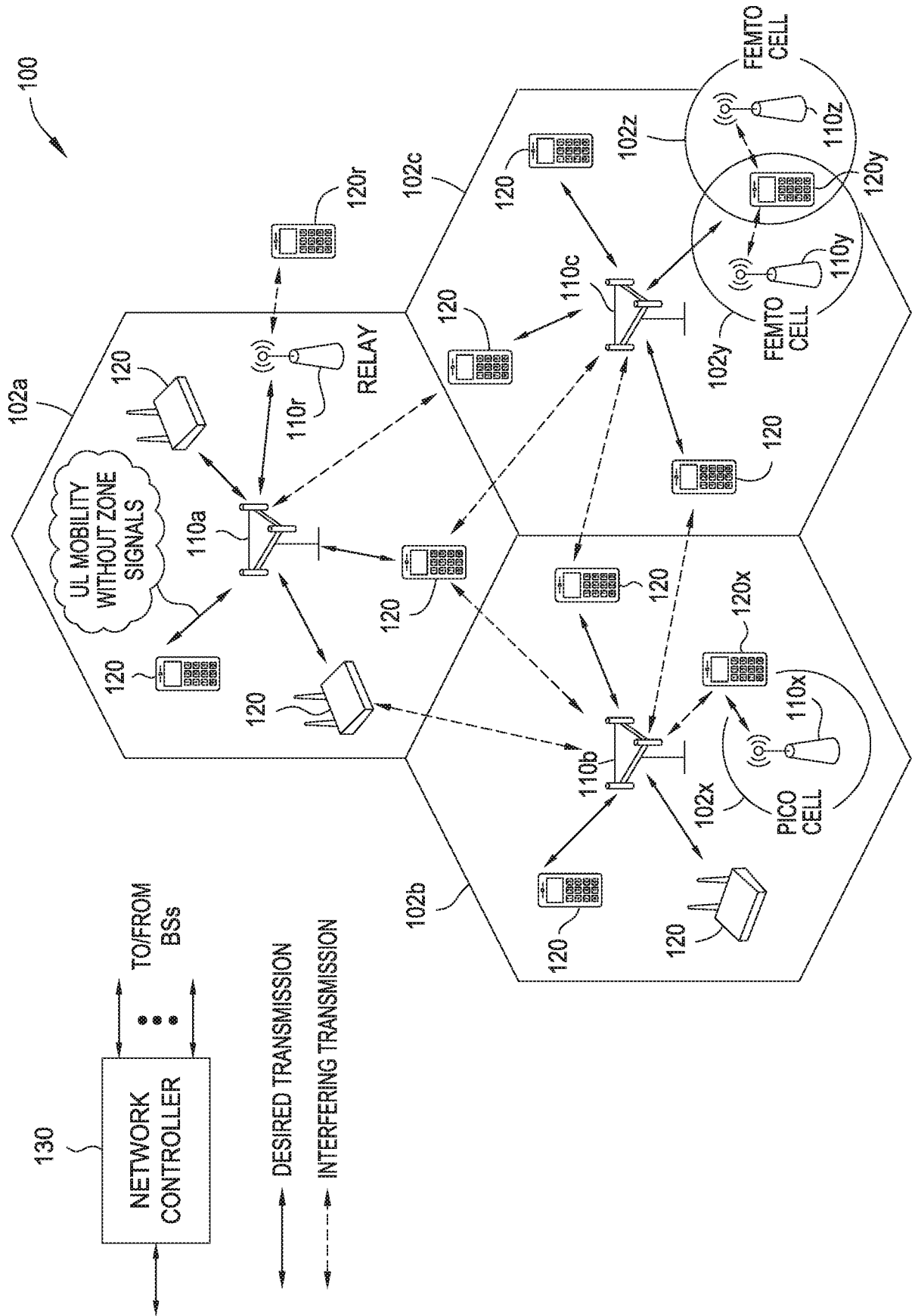

FIG. 1

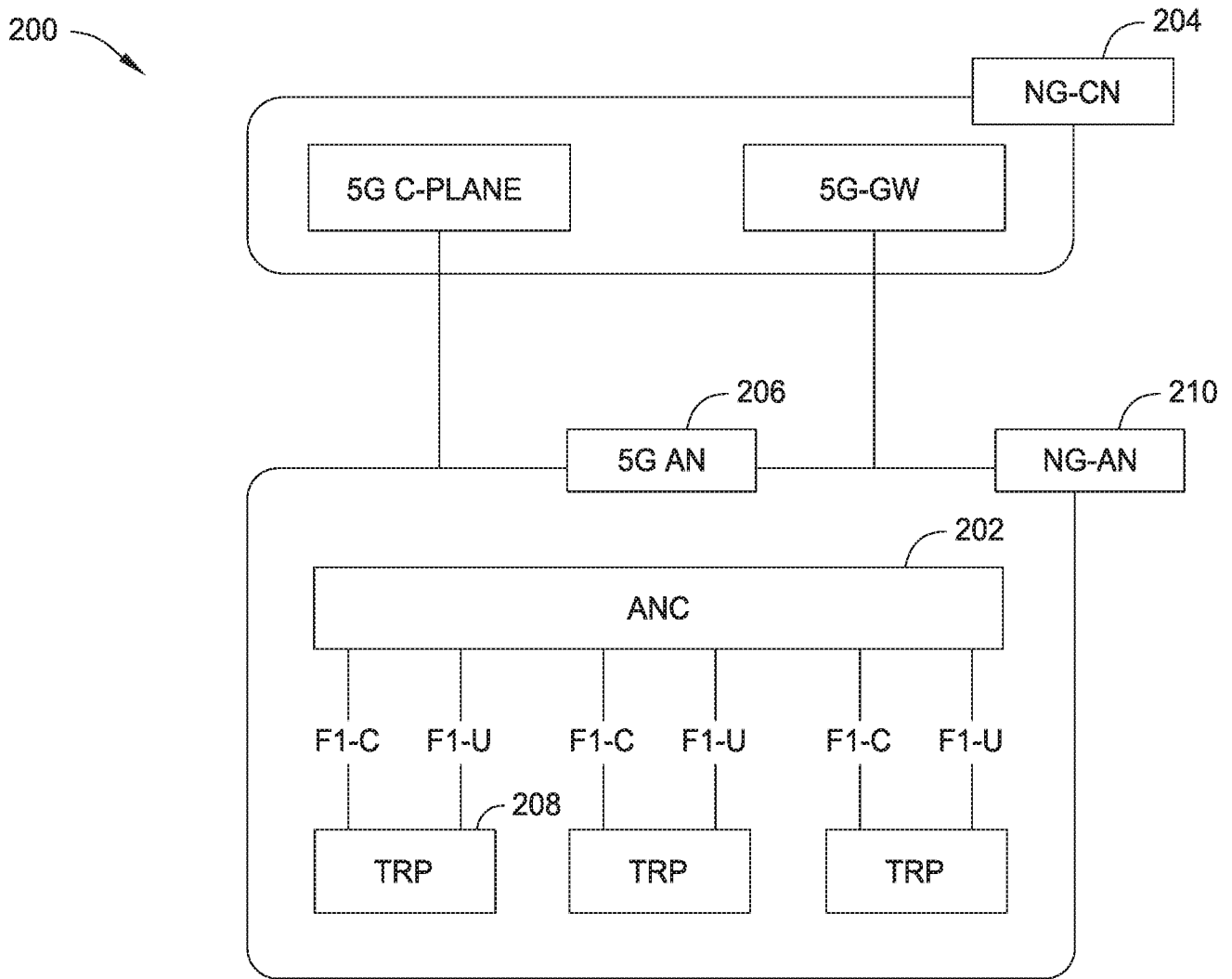

FIG. 2

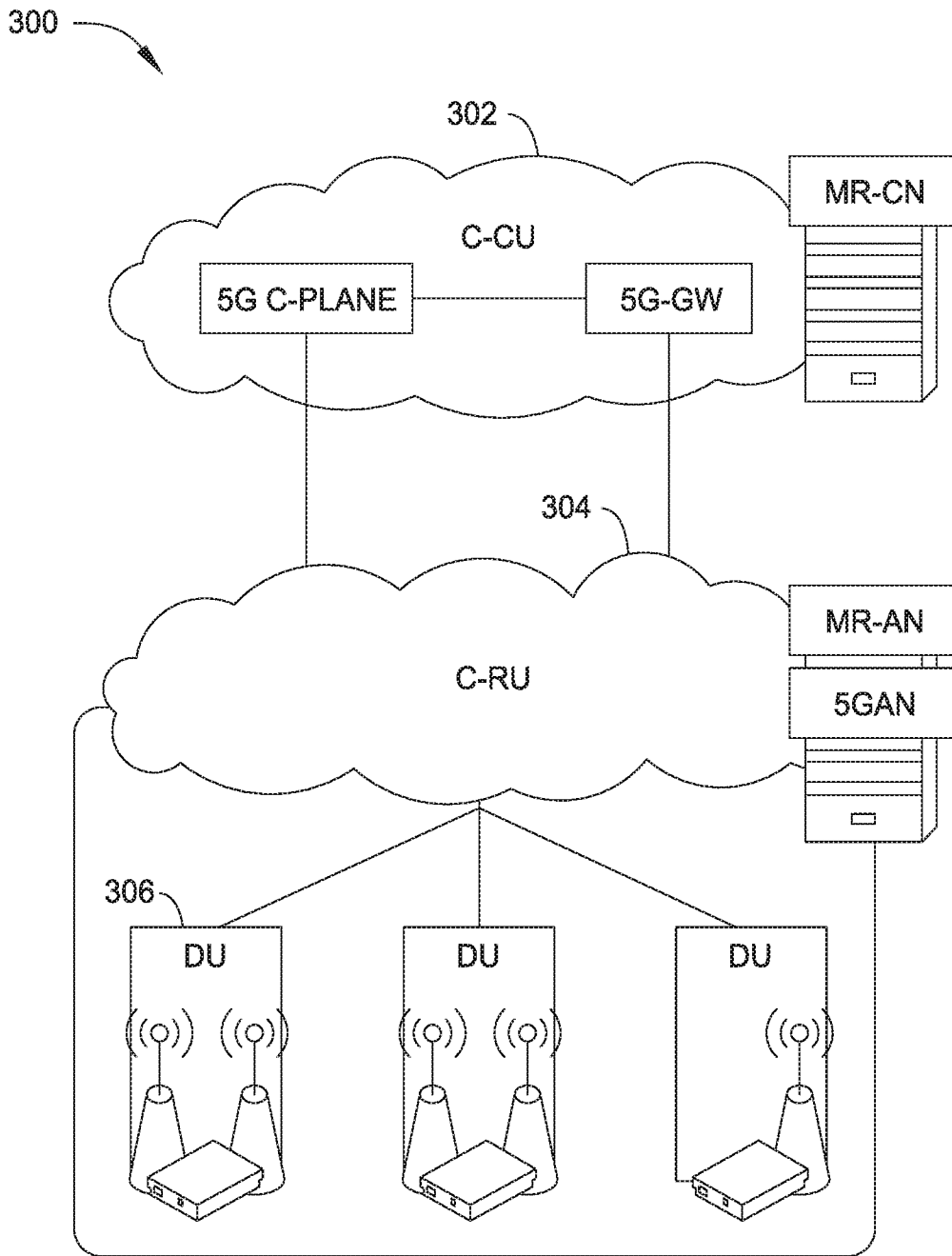

FIG. 3

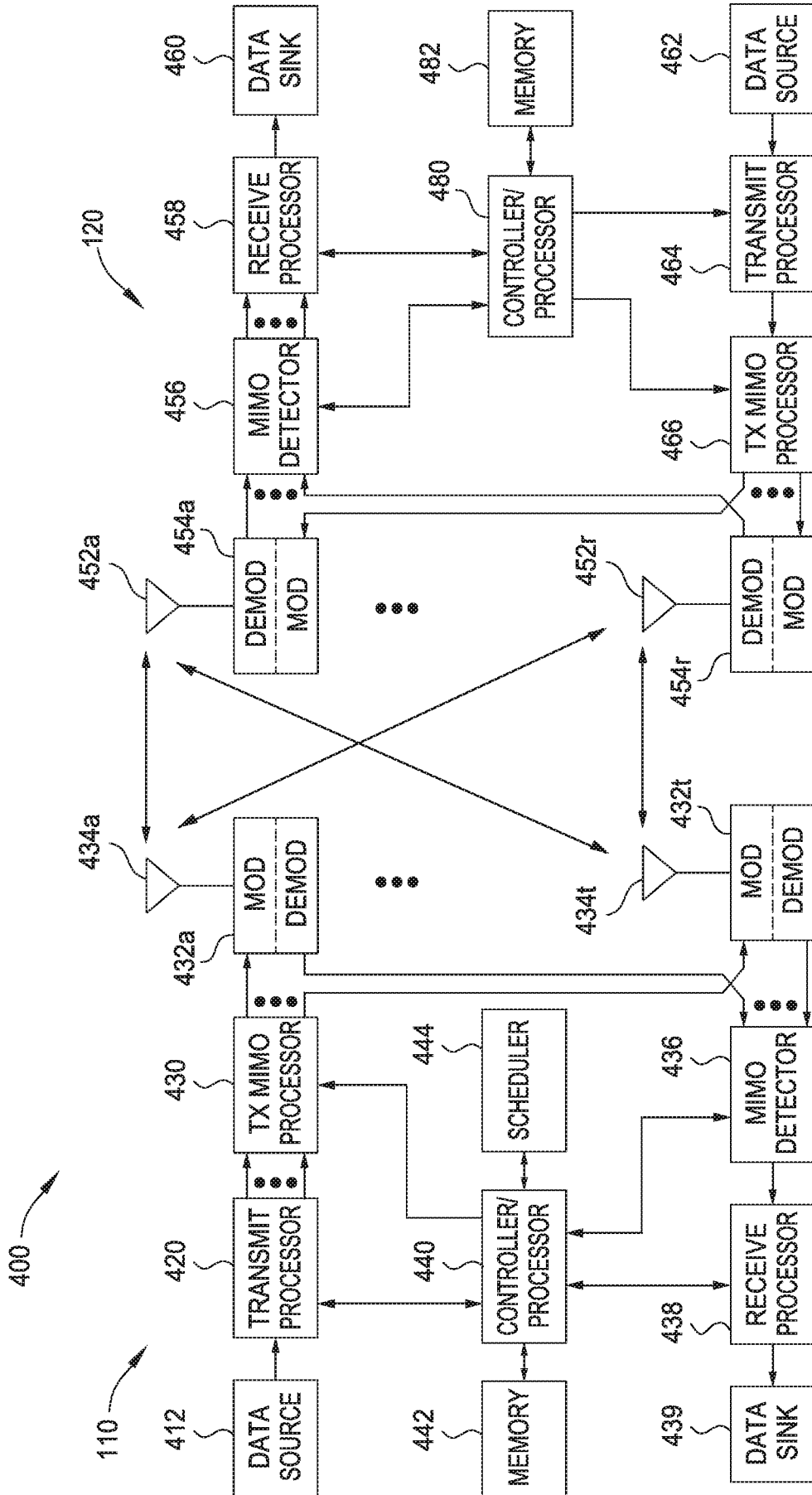

FIG. 4

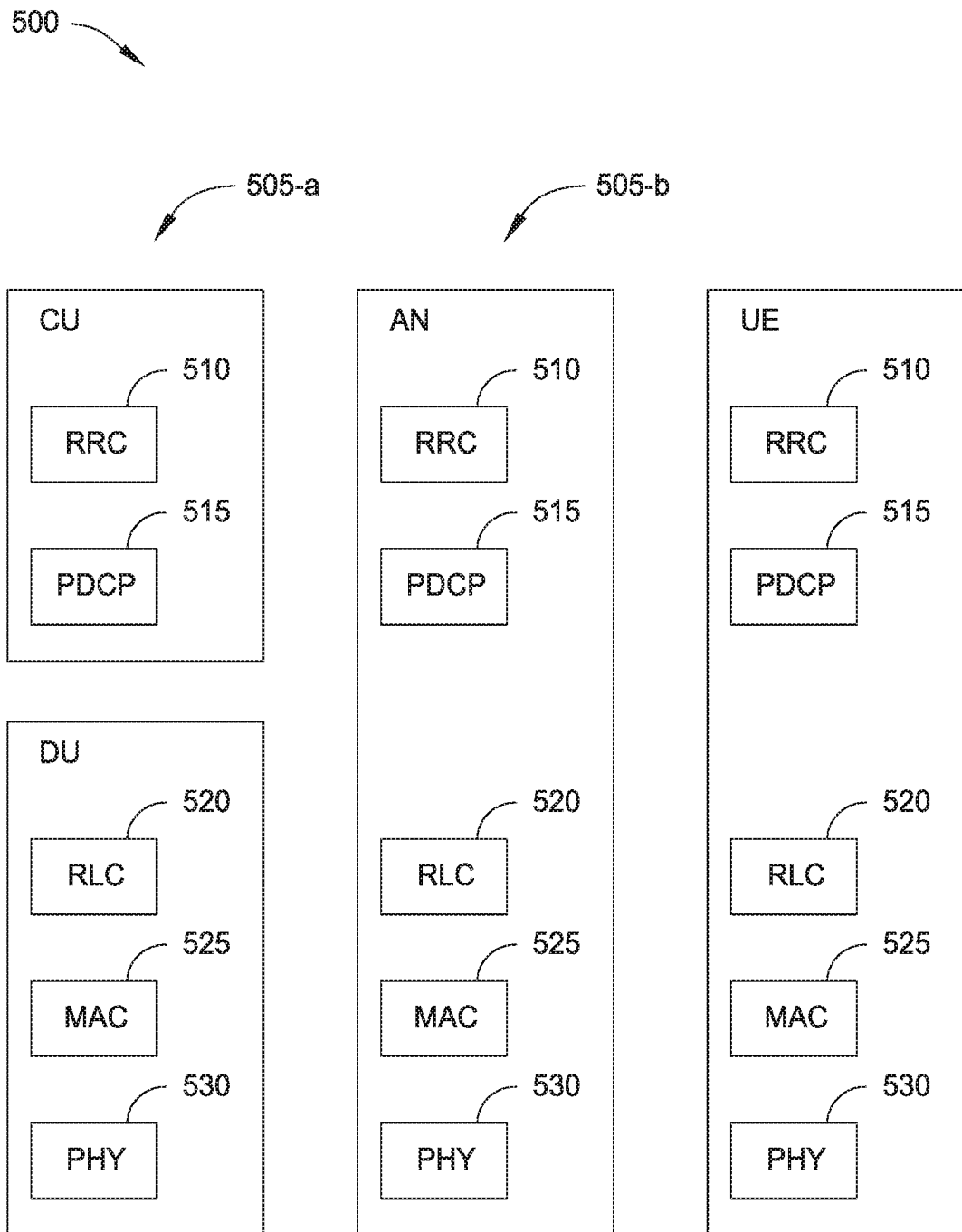

FIG. 5

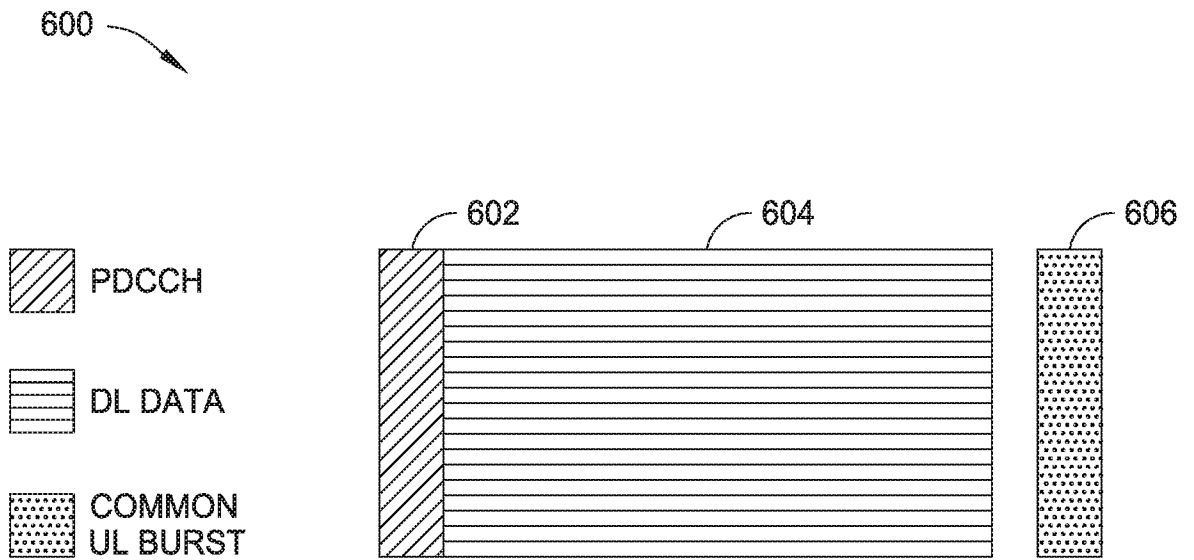

FIG. 6

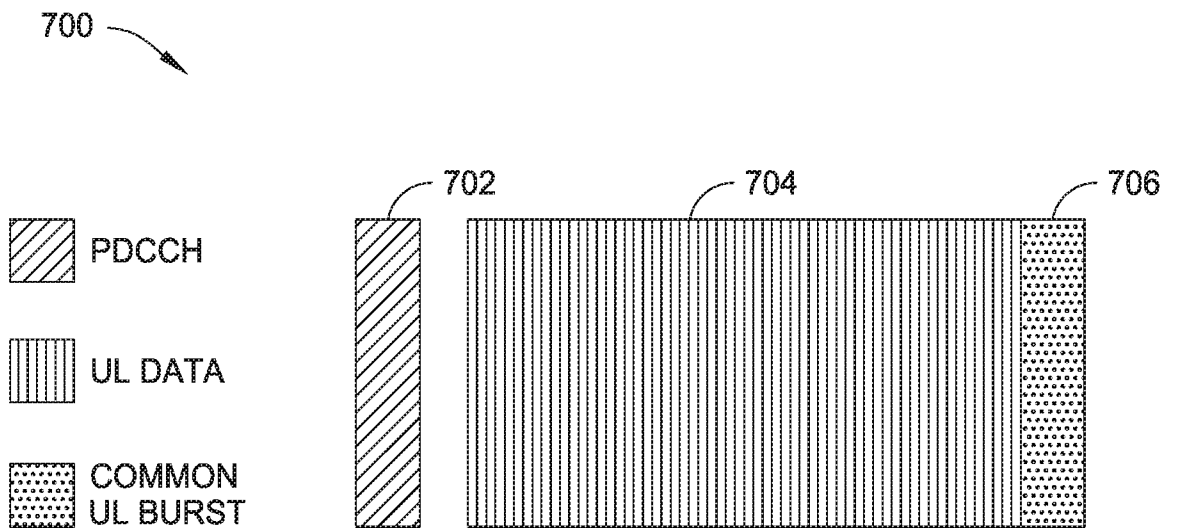

FIG. 7

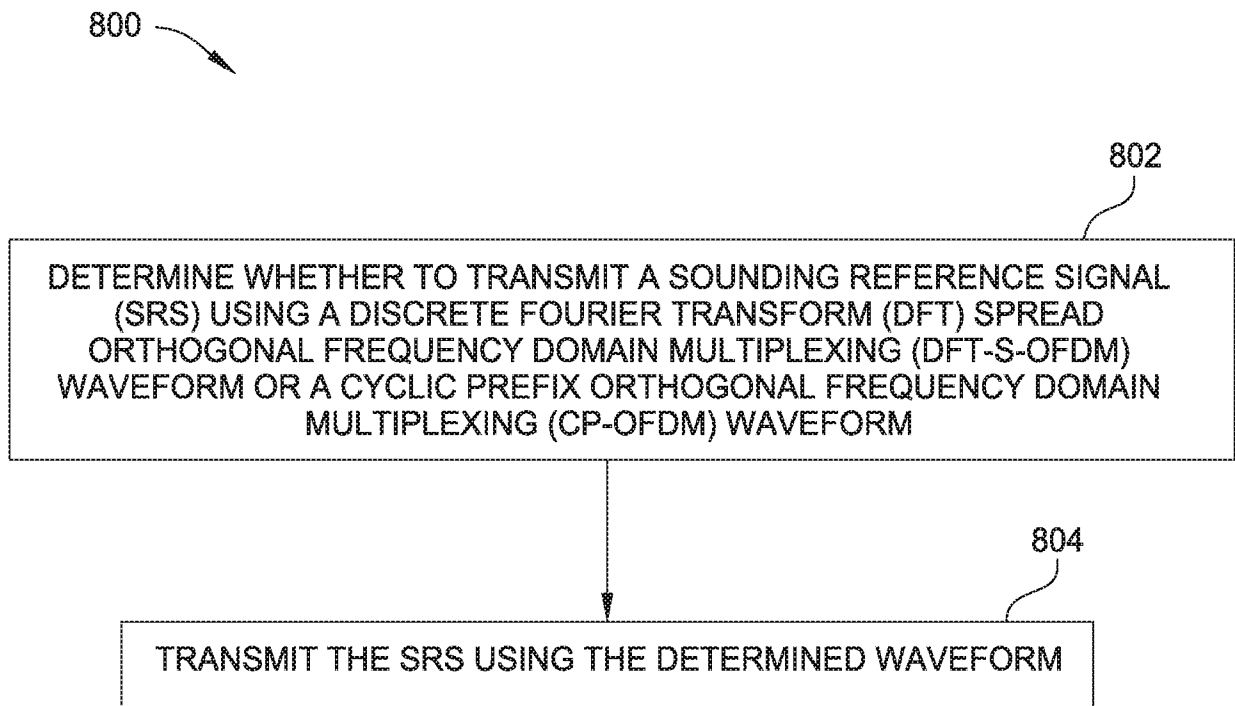

FIG. 8A

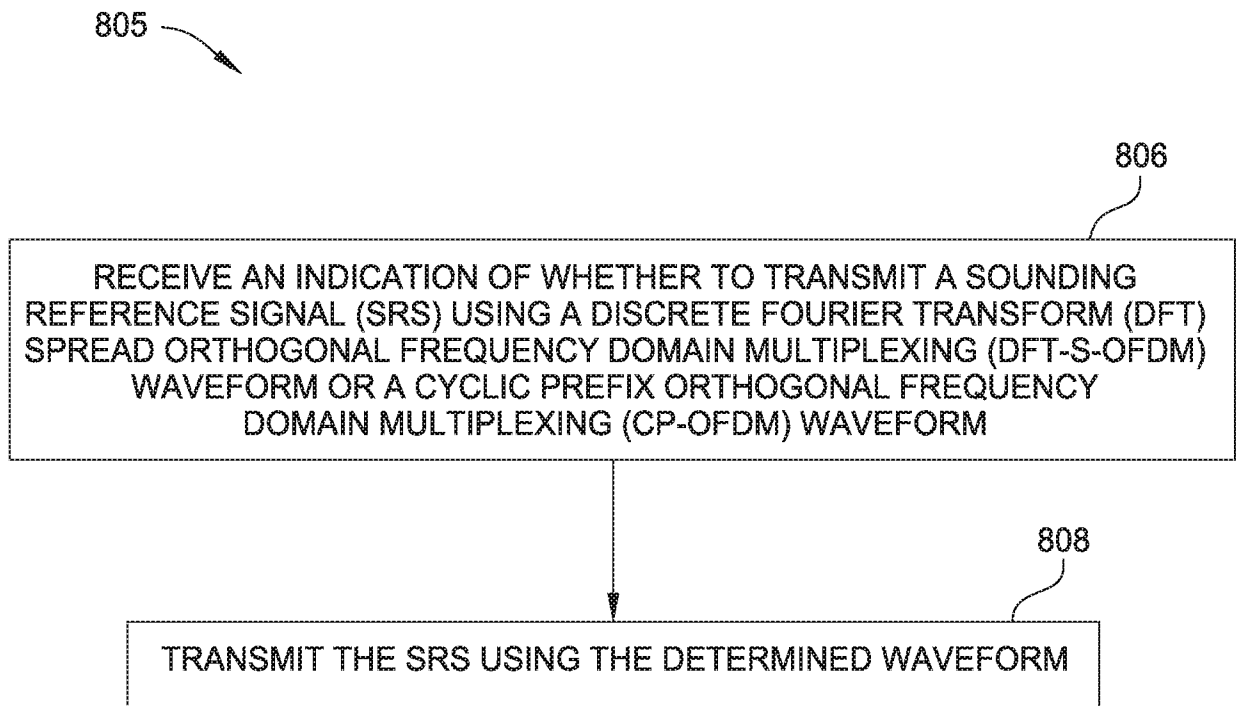

FIG. 8B

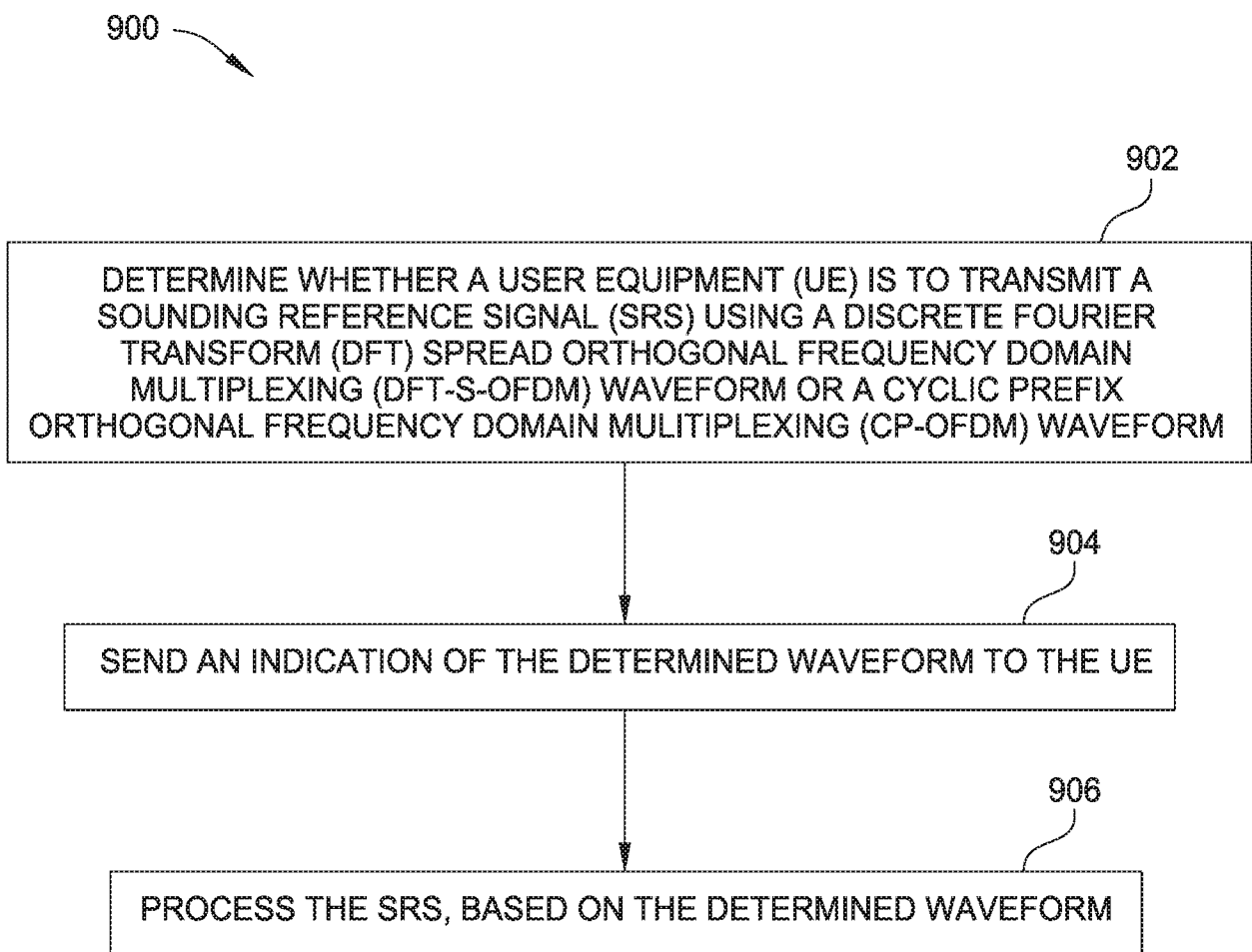

FIG. 9

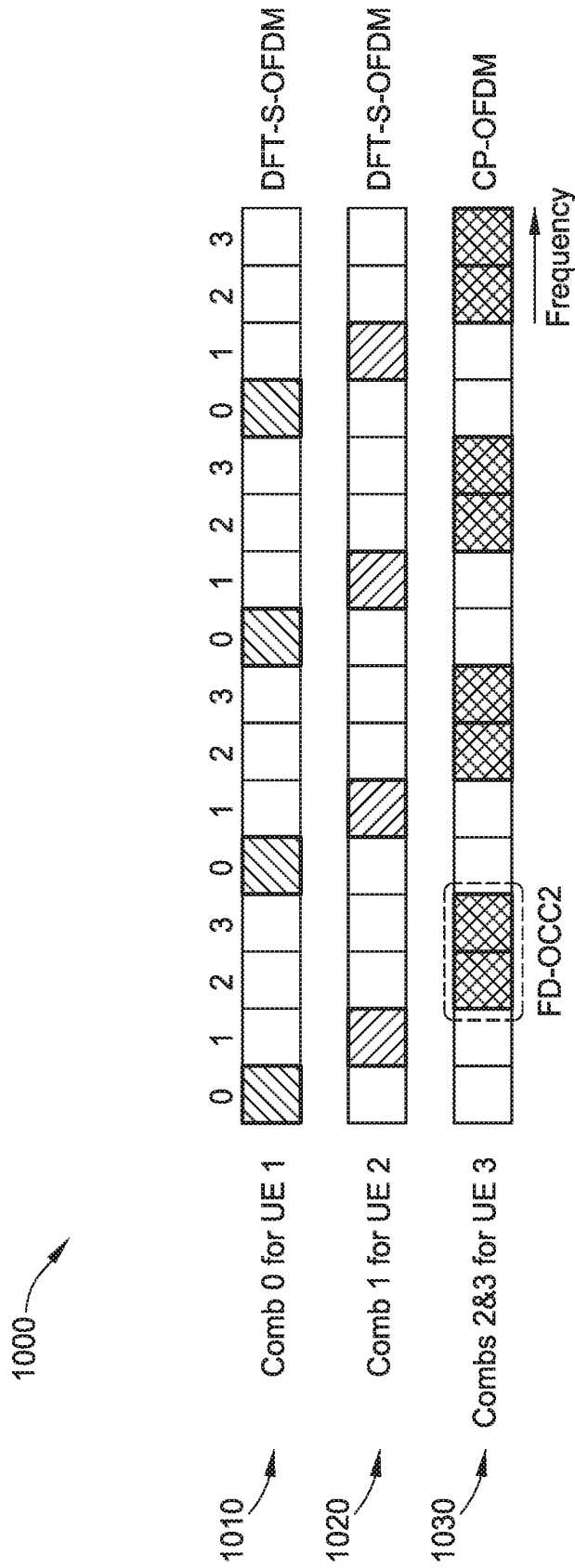

FIG. 10

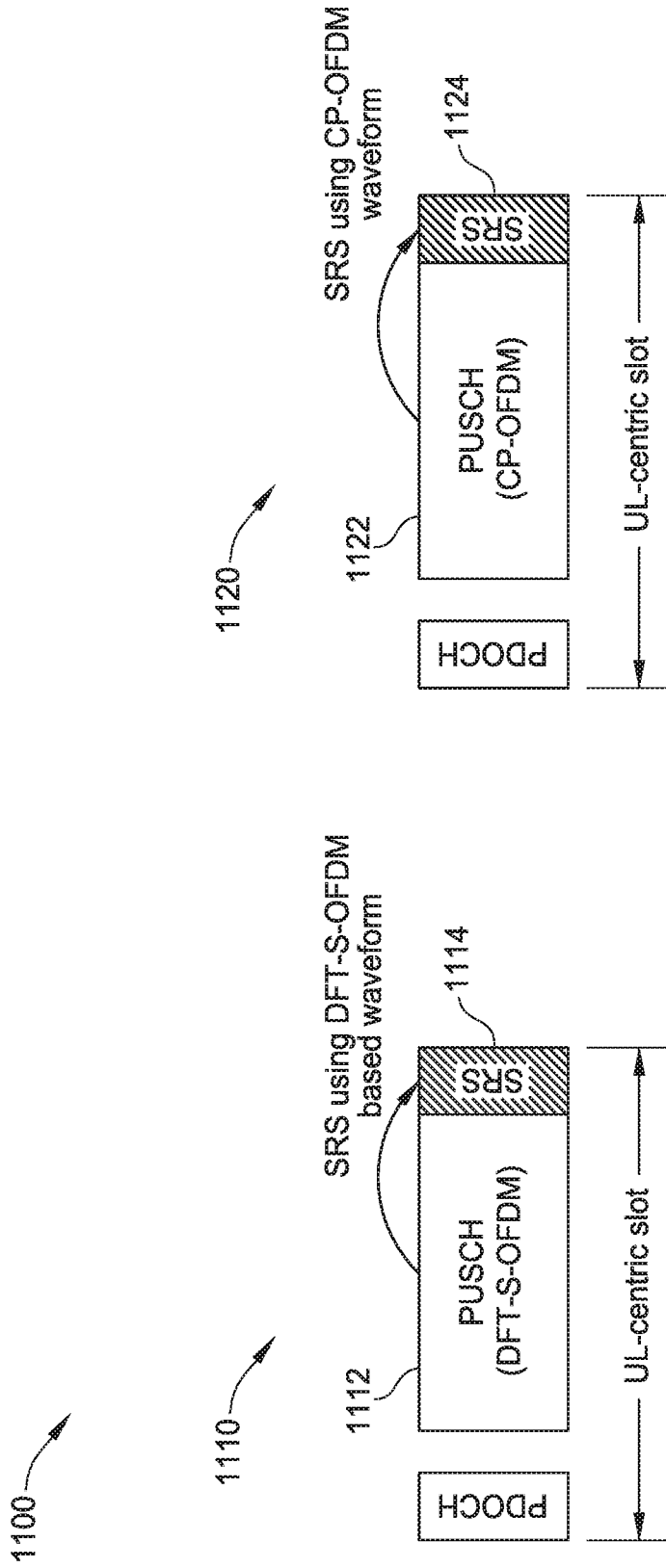

FIG. 11

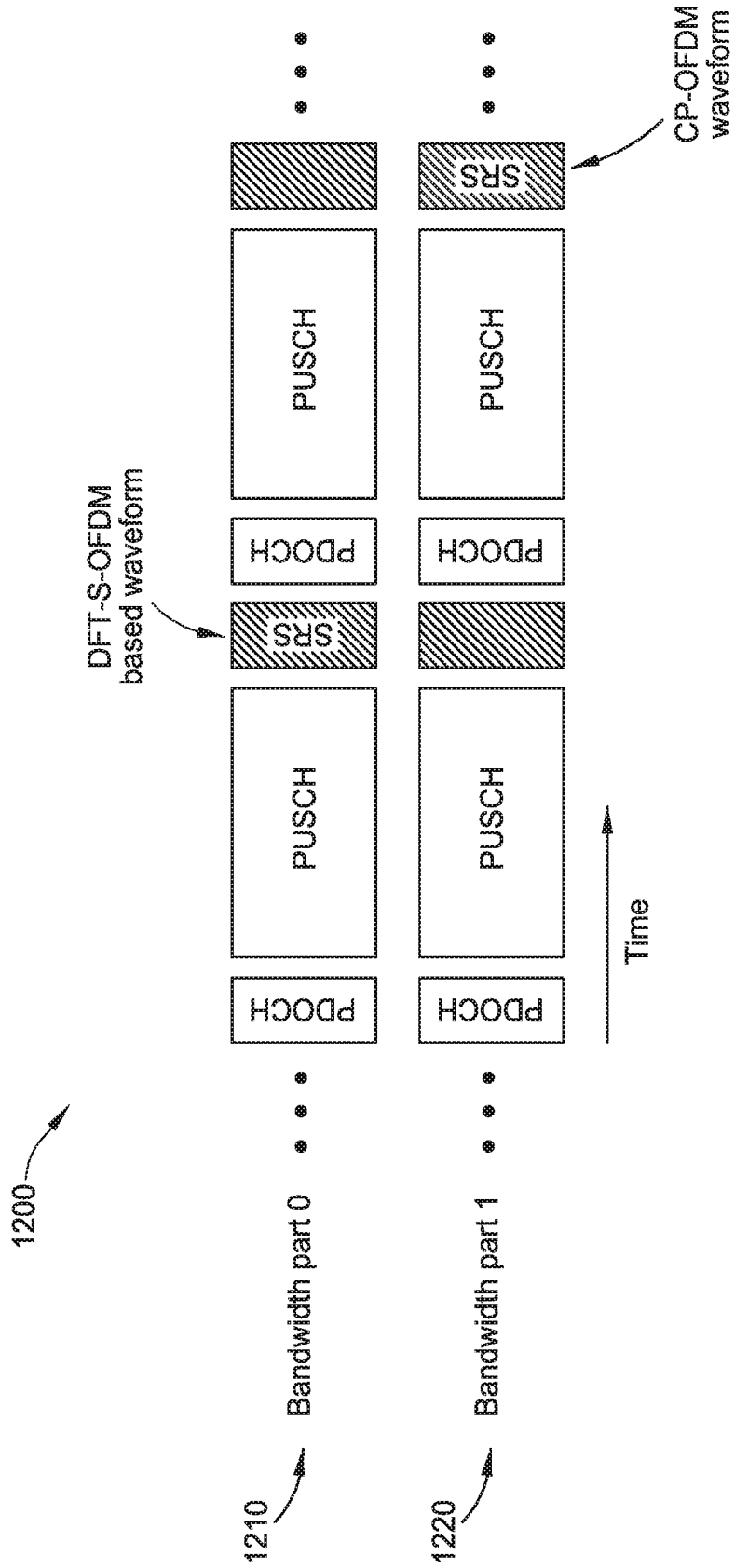

FIG. 12

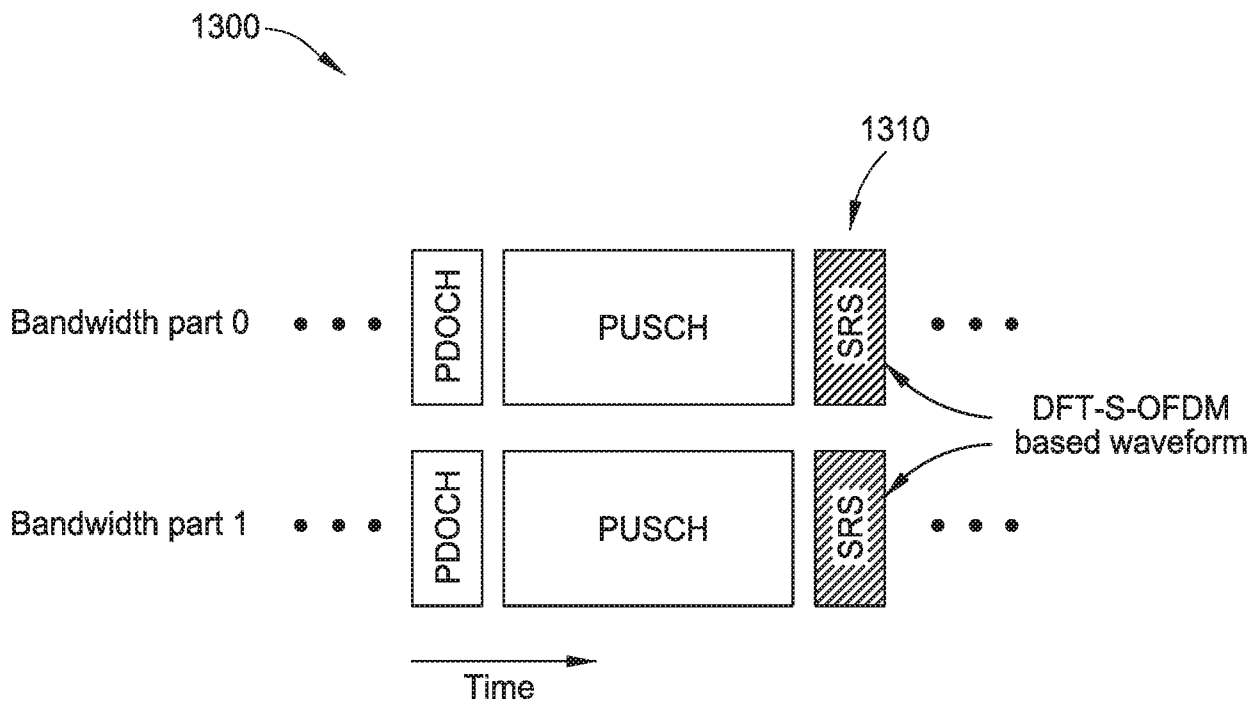

FIG. 13

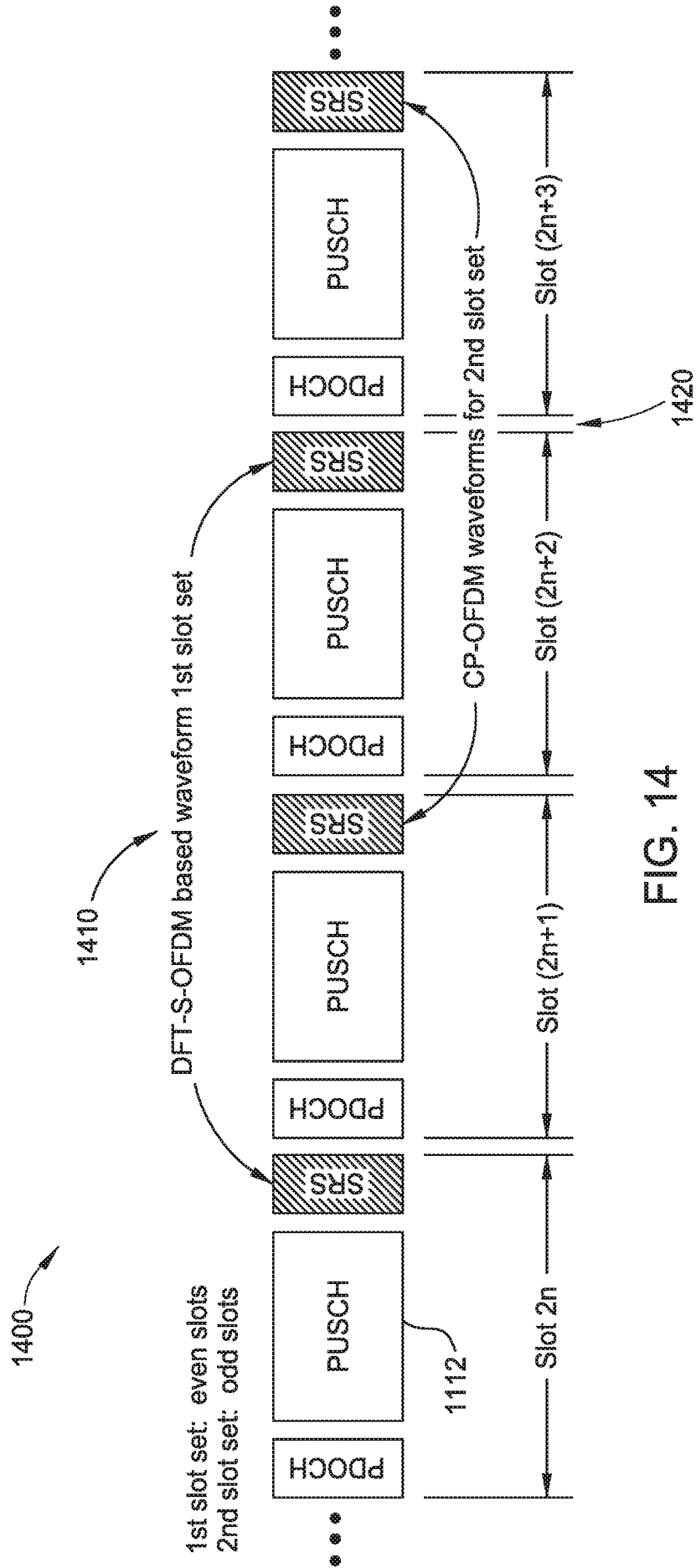

FIG. 14

INTERNATIONAL SEARCH REPORT

International application No.

PCT/CN2018/071683**A. CLASSIFICATION OF SUBJECT MATTER**

H04W 72/04(2009.01)i

According to International Patent Classification (IPC) or to both national classification and IPC

B. FIELDS SEARCHED

Minimum documentation searched (classification system followed by classification symbols)

H04W; H04Q; H04L

Documentation searched other than minimum documentation to the extent that such documents are included in the fields searched

Electronic data base consulted during the international search (name of data base and, where practicable, search terms used)

WPI; EPODOC; CNKI; CNPAT; 3GPP: SRS, Sounding Reference Signal, CPOFDM, CP-OFDM, cyclic prefix OFDM, DFT-S-OFDM, DFTS OFDM, DFT SOFDM, Discrete Fourier Transform spread OFDM, waveform

C. DOCUMENTS CONSIDERED TO BE RELEVANT

Category*	Citation of document, with indication, where appropriate, of the relevant passages	Relevant to claim No.
A	US 2008039098 A1 (TEXAS INSTRUMENTS INCORPORATED) 14 February 2008 (2008-02-14) description, paragraphs [0014] to [0044], and claim 1	1-70
A	CN 105917719 A (MEDIA TEK SINGAPORE PTE. LTD.) 31 August 2016 (2016-08-31) the whole document	1-70
A	CN 102263722 A (ZTE CORPORATION) 30 November 2011 (2011-11-30) the whole document	1-70
A	3GPP. "TSG-RAN WG1 #87 R1-1613162" <i>Summary of e-mail discussions on uplink control signaling</i> , 19 November 2016 (2016-11-19), the whole document	1-70

 Further documents are listed in the continuation of Box C. See patent family annex.

* Special categories of cited documents:

"A" document defining the general state of the art which is not considered to be of particular relevance

"E" earlier application or patent but published on or after the international filing date

"L" document which may throw doubts on priority claim(s) or which is cited to establish the publication date of another citation or other special reason (as specified)

"O" document referring to an oral disclosure, use, exhibition or other means

"P" document published prior to the international filing date but later than the priority date claimed

"T" later document published after the international filing date or priority date and not in conflict with the application but cited to understand the principle or theory underlying the invention

"X" document of particular relevance; the claimed invention cannot be considered novel or cannot be considered to involve an inventive step when the document is taken alone

"Y" document of particular relevance; the claimed invention cannot be considered to involve an inventive step when the document is combined with one or more other such documents, such combination being obvious to a person skilled in the art

"&" document member of the same patent family

Date of the actual completion of the international search

12 February 2018

Date of mailing of the international search report

29 March 2018

Name and mailing address of the ISA/CN

**STATE INTELLECTUAL PROPERTY OFFICE OF THE
P.R.CHINA
6, Xitucheng Rd., Jimen Bridge, Haidian District, Beijing
100088
China**

Authorized officer

LIU, Qingfeng

Facsimile No. (86-10)62019451

Telephone No. (86-10)53961581

INTERNATIONAL SEARCH REPORT
Information on patent family members

International application No.

PCT/CN2018/071683

Patent document cited in search report			Publication date (day/month/year)	Patent family member(s)			Publication date (day/month/year)
US	2008039098	A1	14 February 2008	None			
CN	105917719	A	31 August 2016	EP	3100563	A1	07 December 2016
				WO	2015113499	A1	06 August 2015
				US	2016014753	A1	14 January 2016
CN	102263722	A	30 November 2011	None			