



(51) International Patent Classification:

A24D 3/04 (2006.01) A24D 3/10 (2006.01)
A24D 3/06 (2006.01) A24D 3/16 (2006.01)

(21) International Application Number:

PCT/GB2013/051138

(22) International Filing Date:

2 May 2013 (02.05.2013)

(25) Filing Language:

English

(26) Publication Language:

English

(30) Priority Data:

1207779.8 3 May 2012 (03.05.2012) GB

(71) Applicant: **BRITISH AMERICAN TOBACCO (INVESTMENTS) LIMITED** [GB/GB]; Globe House, 1 Water Street, London WC2R 3LA (GB).

(72) Inventors: **LEWIS, David**; c/o British American Tobacco, Globe House, 1 Water Street, London WC2R 3LA (GB).
DAVIS, Andrew; c/o British American Tobacco, Globe House, 1 Water Street, London WC2R 3LA (GB).
RICHARDSON, John; c/o British American Tobacco, Globe House, 1 Water Street, London WC2R 3LA (GB).
MAJOR, John; c/o British American Tobacco, Globe House, 1 Water Street, London WC2R 3LA (GB).
SAMPSON, John; c/o British American Tobacco, Globe House, 1 Water Street, London WC2R 3LA (GB).

(74) Agents: **HARRISON, Philip** et al.; 200 Aldersgate, London EC1A 4HD (GB).

(81) Designated States (unless otherwise indicated, for every kind of national protection available):

AE, AG, AL, AM, AO, AT, AU, AZ, BA, BB, BG, BH, BN, BR, BW, BY, BZ, CA, CH, CL, CN, CO, CR, CU, CZ, DE, DK, DM, DO, DZ, EC, EE, EG, ES, FI, GB, GD, GE, GH, GM, GT, HN, HR, HU, ID, IL, IN, IS, JP, KE, KG, KM, KN, KP, KR, KZ, LA, LC, LK, LR, LS, LT, LU, LY, MA, MD, ME, MG, MK, MN, MW, MX, MY, MZ, NA, NG, NI, NO, NZ, OM, PA, PE, PG, PH, PL, PT, QA, RO, RS, RU, RW, SC, SD, SE, SG, SK, SL, SM, ST, SV, SY, TH, TJ, TM, TN, TR, TT, TZ, UA, UG, US, UZ, VC, VN, ZA, ZM, ZW.

(84) Designated States (unless otherwise indicated, for every kind of regional protection available):

ARIPO (BW, GH, GM, KE, LR, LS, MW, MZ, NA, RW, SD, SL, SZ, TZ, UG, ZM, ZW), Eurasian (AM, AZ, BY, KG, KZ, RU, TJ, TM), European (AL, AT, BE, BG, CH, CY, CZ, DE, DK, EE, ES, FI, FR, GB, GR, HR, HU, IE, IS, IT, LT, LU, LV, MC, MK, MT, NL, NO, PL, PT, RO, RS, SE, SI, SK, SM, TR), OAPI (BF, BJ, CF, CG, CI, CM, GA, GN, GQ, GW, ML, MR, NE, SN, TD, TG).

Published:

- with international search report (Art. 21(3))
- before the expiration of the time limit for amending the claims and to be republished in the event of receipt of amendments (Rule 48.2(h))

(54) Title: IMPROVEMENTS IN SMOKING ARTICLE FILTERS

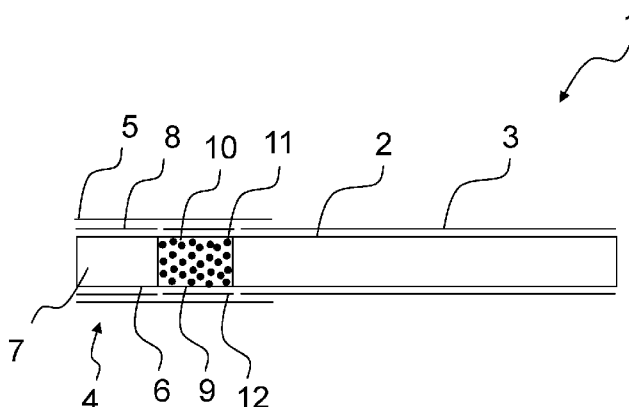

Figure 1

(57) Abstract: The present invention relates to improvements in filters for use in smoking articles such as cigarettes, cigars and cigarillos. The improvements, particularly but not exclusively, relate to filter capabilities and to the manufacture of such filters. In one example, there is provided a filter for a smoking article comprising randomly oriented short length fibres and a flavour release component. The application also describes a filter for a smoking article comprising various other filter arrangements including absorbent and/or adsorbent materials.



Improvements in Smoking Article Filters

Technical Field

The present invention relates to improvements in filters for use in smoking articles.
5 Particularly but not exclusively the improvements relate to filter capabilities and to the manufacture of such filters.

Background

A known filtering material used in cigarette filters is a continuous tow of
10 filamentary cellulose acetate plasticised with triacetin. The cellulose acetate is gathered together to form a rod which is cut to form individual filter segments. The filter for a smoking article may be made of one segment of filter rod, or may be made from multiple segments, with or without a cavity or spaces between them.

15 Summary

In accordance with embodiments of the invention, there is provided a filter for a smoking article comprising randomly oriented short length fibres and a flavour release component.

20 The filter can have a cylindrical shape and an overall circumference of less than about 22mm.

The filter can have an overall circumference of less than about 21mm, 20mm, 18mm, 16mm, 15mm or 14mm.

25

The flavour release component can comprise a thread extending longitudinally through at least a portion of the filter.

The flavour release component can comprise encapsulated flavourant.

30

The flavour release component can comprise one or more capsules or microcapsules.

The flavour release component can comprise one or more capsules having a diameter of between 3 and 8mm.

The flavour release component can comprise a botanical additive.

5

The filter can further comprise an adsorbent material dispersed within an absorbent material, wherein the amount of adsorbent material in mg, C_w , per mm in length, and the amount of absorbent material in mg, T_w , per mm in length, for a filter circumference of about 23 to 25 mm, are in accordance with the range:

10
$$10 \leq (C_w + T_w) \leq 20.$$

The randomly oriented short length fibres can be held together in the filter without the use of a plasticiser.

15 The randomly oriented short length fibres can comprise a first fibrous filter material having an average fibre denier in the range 7 to 9 and a second fibrous filter material having an average fibre denier of below 7, wherein the second fibrous filter material is dispersed within the first fibrous filter material.

20 The second fibrous filter material can have an average fibre denier in the range from 1 to 6.

The randomly oriented short length fibres can comprise fibres having an average length of from about 5mm to 20mm when extended.

25

The filter can comprise randomly oriented short length fibres formed from a first material and randomly oriented short length fibres formed from a second material.

30 The randomly orientated short-length fibres can be formed into a shape other than a cylinder or formed into a cylinder having a circumference greater than 25mm.

In accordance with embodiments of the invention, there is also provided a smoking article comprising a filter as set out above.

Brief Description of the Drawings

Embodiments of the invention will now be described, by way of example only, with reference to the accompanying drawings, in which:

5 Figure 1 is a schematic illustration of a smoking article having a filter with at least one segment having from 12mg of adsorbent material per millimetre of length and 4mg of absorbent material per millimetre of length, for a regular format filter;

Figure 2 is a schematic illustration of a filter making apparatus for use in manufacturing filters as set out herein;

10 Figure 3 is a graph illustrating the carbon weight and tow weight in filters based on desired ranges for filter pressure drop and hardness;

Figure 4 provides three graphs respectively illustrating the influence of carbon weight, tow weight and machinery operating speed on pressure drop for filters;

Figure 5 provides three graphs respectively illustrating the influence of carbon weight, tow weight and machinery operating speed on hardness for filters;

15 Figure 6 is a schematic illustration of a smoking article having a filter with a first fibrous filter material having an average fibre denier in the range 7 to 9 and a second fibrous filter material, dispersed within the first fibrous filter material, having an average fibre denier of below 7;

20 Figure 7 is a schematic illustration of a smoking article having a filter with at least one segment including a nanofibre carrying an additive for enabling or enhancing the reduction of at least one component of main stream smoke;

Figure 8 is a schematic illustration of a smoking article having a filter with at least one segment comprising randomly oriented discrete short length fibres having a thread extending therethrough;

25 Figure 9 is a schematic illustration of a smoking article having a filter with at least one segment comprising randomly oriented discrete short length fibres having a capsule disposed therein;

30 Figure 10 is a schematic illustration of a smoking article having a filter with at least one segment comprising randomly oriented discrete short length fibres having microcapsules disposed therein;

Figure 11 is a schematic illustration of a smoking article having a filter with at least one segment comprising randomly oriented discrete short length fibres having shredded sheet material disposed therein;

Figure 12 is a schematic illustration of a smoking article having a filter with at least one segment comprising randomly oriented discrete short length fibres having degradable fibres disposed therein;

5 Figure 13a is a schematic illustration of a filter rod comprising regions of higher average density and regions of lower average density;

Figure 13b is a schematic illustration of a section of a filter forming band for producing filter segments having regions of higher average density and regions of lower average density;

10 Figure 14 is a schematic illustration of a smoking article having a filter comprising an elliptical cross-section; and

Figure 15 is a schematic illustration of a smoking article having a filter comprising a square cross-section.

Detailed Description

15 As used herein, the term “smoking article” includes smokeable products such as cigarettes, cigars and cigarillos whether based on tobacco, tobacco derivatives, expanded tobacco, reconstituted tobacco or tobacco substitutes and also heat-not-burn products. Such smoking articles may be provided with a filter for the gaseous flow drawn by the smoker.

20 Smoking articles such as cigarettes and their formats are often named according to the cigarette length: “regular” (typically in the range 68 -75 mm, e.g. from about 68 mm to about 72 mm), “short” or “mini” (68 mm or less), “king-size” (typically in the range 75 - 91mm, e.g. from about 79 mm to about 88 mm), “long” or “super-king” (typically in the range 91-105 mm, e.g. from about 94 mm to about 101 mm) and “ultra-long” (typically in the range from about 110 mm to about 121 mm).

They are also named according to the cigarette circumference: “regular” (about 23-25 mm), “wide” (greater than 25 mm), “slim” (about 22-23 mm), “demi-slim” (about 19-22 mm), “super-slim” (about 16-19 mm), and “micro-slim” (less than about 16 mm). Accordingly, a cigarette in a king-size, super-slim format will, for example, have a length of about 83 mm and a circumference of about 17 mm.

30 Cigarettes in the regular, king-size format are preferred by many customers, namely

with a circumference of from 23 to 25 mm and an overall length of from 75 to 91 mm.

Each format may be produced with filters of different lengths, smaller filters being generally used in formats of smaller lengths and circumferences. Typically the filter length will be from 15mm, associated with short, regular formats, to 30mm, associated with ultra-long super-slim formats. The tipping paper will have a greater length than the filter, for example from 3 to 10mm longer.

Figure 1 is a schematic illustration of a smoking article 1 having a filter. The smoking article 1 is in the regular, king size format, namely having a length in the range 75 - 91mm and a circumference in the range 23 to 25mm. The smoking article 1 includes a tobacco rod 2 wrapped in a wrapping material 3, in this case cigarette paper, connected longitudinally to a filter 4 by tipping material 5 overlaying the filter 4 and partially overlaying the wrapping material 3. The filter 4 comprises a first segment 6 at the mouth-end of the filter 4 comprising crimped cellulose acetate tow 7 wrapped in a first plug wrap 8, and a second segment 9 at the tobacco rod end of the filter 4 comprising adsorbent material 10 having an adsorbent material 11 dispersed therein and wrapped in a second plug wrap 12.

The first segment 6 is a cellulose acetate segment formed using continuous cellulose acetate fibres and a plasticiser.

The adsorbent material 10 of the second segment 9 comprises randomly oriented discrete short length cellulose acetate fibres and the adsorbent material 11 comprises activated carbon particles. The randomly oriented discrete short length cellulose acetate fibres of the second segment 9 are non-plasticised fibres. The randomly oriented discrete short length cellulose acetate fibres of the second segment 9 comprise 8 denier, 10mm fibre lengths. However, other denier fibres or fibre lengths can be used. For instance, fibre deniers in the range 5 to 9 or 7 to 9 can be used. In terms of fibre length, when used herein, the term 'short length' means fibre lengths of fibres in the form used in a filter segment (i.e. crimped or uncrimped as appropriate) which are shorter than the length of the filter segment.

Average fibre lengths (when the fibres are extended) in the range from 5mm to 25mm, or from 6mm to 20mm, 7mm to 20mm or 7mm to 15mm can be used. The activated carbon particles are in the present example coconut carbon provided in a 30/70 mesh size, although other carbons and /or sizes can be used. For instance,
5 particles with diameters in the range of approximately 0.1 to 1.0mm, or approximately 0.2 to 0.9mm, 0.2 to 0.8mm, 0.2 to 0.7mm, 0.2 to 0.6mm, 0.3 to 0.9mm, 0.3 to 0.8mm, 0.3 to 0.7mm or 0.3 to 0.6mm can be used.

The second segment 9 has 12mg of adsorbent material per millimetre of length and
10 4mg of adsorbent material per millimetre of length. However, in alternative examples, the amount of adsorbent can be anywhere in the range from 6mg to 16mg per mm length on average, or from 7mg to 16mg, 8mg to 16mg, 9mg to 16mg, 10mg to 16mg, 11mg to 16mg, 12mg to 16mg, or 13mg to 16mg per mm length and the amount of adsorbent can be from 1.5mg to 8mg per mm length on average, or from
15 1.5mg to 7mg, 1.5mg to 6mg, 1.5mg to 5mg, or 1.5mg to 4mg, all of these ranges being for a regular format filter, i.e. having a circumference of about 23 to 25 mm. It has been found that these parameters enable the filter to exhibit desirable pressure drop and hardness levels for consumer acceptable smoking articles, while increasing the level of adsorbent or other granular additive in the filter over known
20 filters.

The filter material of the second segment 9, for instance, exhibits desirable pressure drop in the range 500 to 700 mmWg for an experimental sample having a 144mm filter length (3.47 to 4.86 mmWg/mm) and desirable hardness of between 85% to
25 95% according to the Filtrona filter hardness measure (defined as the compressed diameter of the filter rod as a percentage of the initial rod diameter, the compression of the rod being caused by a known weight applied through a circular foot for a specific period of time). Alternative weights of adsorbent material and adsorbent material per mm of filter length would be used for filters in formats other
30 than regular, for instance having slimmer or wider average diameters, as would be appreciated by those skilled in the art.

An increase in the pressure drop and/or hardness percentage resulting from an increase in the amount of adsorbent per mm in a filter can be offset by a decrease in the amount of adsorbent per mm. Also, an increase in the pressure drop and/or hardness percentage resulting from an increase in the amount of adsorbent per mm
5 in a filter can be offset by a decrease in the amount of adsorbent per mm. The inventors have, in particular, found that the amount of adsorbent material in mg, C_w , per mm in length for a regular format smoking article, and the amount of adsorbent material in mg, T_w , per mm in length for a regular format smoking article, can be determined in accordance with the range:

10
$$10 \leq (C_w + T_w) \leq 20,$$

these values enabling the filter to exhibit appropriate levels of filter pressure drop and hardness, such as those discussed above.

15 Particular benefits can be achieved if the amount of adsorbent material and the amount of adsorbent material in mg per mm of length for a regular circumference smoking article fall within the range:

$$11 \leq (C_w + T_w) \leq 18,$$

20 or more particularly within the range:

$$12 \leq (C_w + T_w) \leq 17.$$

Advantages can also be achieved using adsorbent and adsorbent weights, in mg per
25 mm of length for a regular circumference smoking article, in other ranges, including $10 \leq (C_w + T_w) \leq 19$, $10 \leq (C_w + T_w) \leq 18$, $10 \leq (C_w + T_w) \leq 17$, $11 \leq (C_w + T_w) \leq 20$, $12 \leq (C_w + T_w) \leq 20$, $13 \leq (C_w + T_w) \leq 20$ and $14 \leq (C_w + T_w) \leq 20$.

In addition to selected adsorbent and adsorbent weights per mm falling within the
30 above ranges, at least one of the adsorbent and adsorbent weight C_w , T_w can be greater than a minimum level. For instance, the adsorbent level can be equal to or greater than about 1.5mg per mm in some embodiments of the invention and/or the adsorbent can be equal to or greater than 6mg per mm, both minimum levels being for a regular circumference filter, of about 23mm to 25mm.

The above ranges can also be applied for use with granular additives other than adsorbents, such as certain flavourants (where local regulations permit).

- 5 The second filter segment 9 can be manufactured using a filter manufacturing apparatus such as the Turmalin apparatus available from Hauni Maschinenbau AG in Germany.

10 In cases in which the adsorbent weight per mm is less than 3.5mg per mm and/or the adsorbent weight per mm is less than 9mg per mm (both for a regular circumference smoking article), and/or the combined adsorbent and adsorbent weight per mm is at the lower end of the above ranges, for instance 12mg per mm or lower, the inventors have determined that a reduction in hardness caused by these low weights can be offset by using, for instance, a stiffer plug wrap and/or
15 stiffer tipping material surrounding the filter. For instance, the plug wrap and/or tipping could have a basis weight of greater than 30g/m², greater than 40g/m², greater than 50g/m², greater than 60g/m², greater than 70g/m² or greater than 80g/m². Alternatively, multiple layers of plug wrap and/or tipping material can be used.

20 Known Dalmatian filters, i.e. those comprising carbon particles dispersed in continuous cellulose acetate tow cut according to the required segment length, in the regular format, generally have an upper carbon loading limit of 5mg/mm in order to keep the pressure drop at levels desirable for consumers. Higher loading
25 could result in the pressure drop being too high. If it was desired to have a higher loading then, in the past, it was usually necessary to use a cavity triple filter, having mouth-end and tobacco end cellulose acetate tow sections with a carbon filled cavity between them. Such cavity filters result in the removal of a quantity of cellulose acetate for a given filter length and so this can have a negative effect, for
30 instance on particular aspects of tar filtration and phenol selectivity. As such, there are clear advantages to being able to increase the loading of additives without causing too great a pressure drop and without the removal of filtration material.

The present inventors accordingly have recognised that by using randomly oriented discrete short length cellulose acetate fibres for forming the filter, manufactured using a filter manufacturing apparatus such as the Turmalin apparatus available from Hauni Maschinenbau AG in Germany, and by selecting the amount of
5 adsorbent to be in the range from 6mg to 16mg per mm on average, and the amount of absorbent to be in the range from 1.5mg to 8mg per mm on average (or the other ranges and limits set out above), for a regular circumference cigarette, improved filters can be provided whilst maintaining acceptable pressure drop and filter hardness parameters.

10

Figure 2 is a schematic illustration of a filter making apparatus, such as the Turmalin apparatus available from Hauni Maschinenbau AG in Germany, for use in manufacturing filters.

15 Referring to Figure 2, a source 21 of cellulose acetate or other filter material is supplied to the filter making apparatus 20, which comprises a plurality of modules 22 - 26. A feeder module 22 receives the supply of filter material, for instance crimped continuous fibres such as crimped cellulose acetate tow, from which it is fed into a cutter and randomiser 23. The cutter and randomiser 23 cuts the filter
20 material into short staple lengths, for instance 10mm lengths. Other fibre lengths can be used, as described above in relation to the smoking article 1 described with reference to Figure 1. A filter bander 24 includes a vacuum band onto which the cut filter material is provided. This is fed into a rod former 25, for forming the band of cut filter material into a rod which is wrapped with a plug wrap. Finally, a
25 segment cutter 26 is used to cut the rod into filter segments of a desired length.

The filter bander 24 comprises a carding unit which distributes the cut fibres evenly onto the vacuum band, and a plurality of hoppers, two in the present example, for applying additives, for instance in the form of granules or additional fibres. There
30 is also an add-back system which can be used if required to feed a third additive into the band of cut filter material. The add-back system alternatively may be used to feed any loose cut filter material back into the cutter and randomiser 23 to reduce wastage. The filter bander 24 comprises metering rollers which are adjustable to

permit control over the additive loading and to ensure uniformity of the band of cut filter material as it is formed. The filter bander 24 also comprises a jet inserter for enabling liquids such as flavours (where local regulations permit the use of flavours) to be injected directly into the filter rod.

5

In use, the Turmalin apparatus operates as follows: the feeder module 22 feeds filter material such as crimped cellulose acetate tow into the cutter and randomiser 23. The cutter and randomiser 23 cuts the tow fibres into short staple lengths of 10mm in the present example. The cut filter material is blown to the carding unit of the filter bander 24 from which it is sucked onto the vacuum band, where it is formed into a band of randomly orientated filter material. The bander 24 operates in such a way that the resultant band of filter material is mechanically bonded. Additives are fed into the air stream carrying the filter fibres, and the rod former 25 forms the band into a continuous filter rod, which is bound by a filter plug wrap. The segment cutter 26 cuts the continuous filter rod, comprising randomly orientated fibres, into segments of a desired length.

Appreciated advantages of the Turmalin apparatus include: the inclusion of additives, for example carbon, at higher loadings; retention of the activity of carbon additives because without plasticisers such as triacetin there is no poisoning of the charcoal; and a longer product life. The filter designs and manufacturing developments created by the inventors which are described below lead to further advantages and improvements.

It is possible to generate a series of filter capability curves for differing tow weights, additive loadings and machinery operating speeds, such that filter designs can be optimised to desired filter characteristics, such as pressure drop and hardness level. This thereby increases the range of different filters which can be manufactured, and which may have purposely different capabilities depending on the requirements for a particular product.

Figure 3 is a graph illustrating the additive weight (in the present case carbon weight) and tow weight in filters based on preferred ranges for their pressure drop

and hardness. In particular, the tow weight and carbon weight required for a filter pressure drop of from 500 to 700 mmWg for a 144mm filter length (3.47 to 4.86 mmWg/mm) and for a filter hardness level from 85% to 95%, according to the Filtrona filter hardness measure, are indicated in the graph, which represents data
5 from filters produced using the Hauni Turmalin apparatus. The device can be operated at speed settings from below 50m/min up to over 200m/min. The carbon used was 30/70 mesh coconut carbon, dispersed within 8 denier non-plasticised, crimped randomly oriented cellulose acetate tow fibres cut to 10mm lengths. For these particular filter parameters, the resulting contour plot of Figure 3 illustrates
10 the range of tow and carbon weights per mm for a regular circumference smoking article which can be obtained while achieving desired characteristics such as pressure drop and hardness within predefined ranges.

In relation to the pressure drop of the filter, Figure 4 is a graph illustrating the
15 influence of carbon weight, tow weight and machinery operating speed on pressure drop for filters. Again, the carbon used was 30/70 mesh coconut carbon, dispersed within 8 denier non-plasticised, crimped randomly oriented cellulose acetate tow fibres cut to 10mm lengths. While the operating speed of the machinery has relatively little effect on the pressure drop and the tow weight has a generally linear
20 relationship, surprisingly the inventors have realised that an increased carbon weight beyond 10mg/mm can be shown in some cases to reduce filter pressure drop for a given tow density, based on filters manufactured using the Turmalin apparatus. This is a significant result, indicating that the level of carbon can be increased beyond 10mg/mm without having an adverse influence on filter pressure drop.

25
In relation to the hardness of the filter, Figure 5 provides three graphs illustrating the influence of carbon weight, tow weight and machinery operating speed on hardness for filters. Again, the carbon used was 30/70 mesh coconut carbon, dispersed within 8 denier non-plasticised, crimped randomly oriented cellulose
30 acetate tow fibres cut to 10mm lengths. In a similar way to pressure drop, while the operating speed of the machinery has relatively little effect on the hardness and the tow weight has a generally linear relationship, surprisingly the inventors have realised that an increased carbon weight beyond 10mg/mm in fact reduces filter

hardness for a given tow density for filters manufactured using the Turmalin apparatus. This is a significant result, indicating that the level of carbon can be increased beyond 10mg/mm without having an adverse influence on filter hardness.

- 5 Although the additive in the above embodiments has been described as particles of adsorbent, in particular activated carbon, other adsorbents, or other additives, can also be used. For instance, the adsorbent could be an ion exchange resin, such as CR20, or other materials such as zeolite, silica gel, meerschaum, aluminium oxide (activated or not), carbonaceous resin, magnesium silicate, including Sepiolite
- 10 $(\text{Mg}_4\text{Si}_6\text{O}_{15}(\text{OH})_2 \cdot 6\text{H}_2\text{O})$ or combinations thereof with or without activated carbon. Also, other additives which modify the smoke drawn through the filter, such as flavourant (where local regulations permit the use of flavourants) for example menthol crystals, or humectant particles, can be used.
- 15 It has previously been known to manufacture filters comprising randomly oriented discrete tow fibres, for example as described in WO 2009/093051. However, similar to conventional acetate tow filters, the manufacturing technique described in WO 2009/093051 can also require the use of a plasticising agent, e.g. triacetin, to cause bonding within the randomly orientated fibres to give a firm structure. An
- 20 advantage of the Turmalin apparatus is that it does not require the use of a plasticising agent. The Turmalin apparatus causes a mechanical bonding within the fibres making the need for plasticiser obsolete. Any undesirable effects caused by using products such as triacetin are therefore eliminated.
- 25 In addition to the above advantage, the present inventors have appreciated that the Turmalin apparatus, or similar, enables various filter designs to be made which offer additional improvements and advantages. Such improvements and advantages are described in detail below.
- 30 The inventors have appreciated that the capabilities of the filters manufactured using a process such as that of the Turmalin apparatus can be improved by using materials with smaller particle sizes than traditionally used. Smaller particles can enhance that filtration performance because they have larger surface area.

Figure 6 is a schematic illustration of a smoking article 31. The smoking article 31 comprises a tobacco rod 32 wrapped in a wrapping material 33, in this case cigarette paper, connected longitudinally to a filter 34 by tipping material 35 overlaying the filter 34 and partially overlaying the wrapping material 33. The filter 34 comprises a first segment 36 at the mouth-end of the filter 34 comprising crimped cellulose acetate tow 37 wrapped in a first plug wrap 38, and a second segment 39 at the tobacco rod end of the filter 34 comprising a first absorbent material 40 and a second absorbent material 41 wrapped in a second plug wrap 42.

10

The first segment 36 is a cellulose acetate segment formed using continuous cellulose acetate fibres and a plasticiser.

15 The first absorbent material 40 comprises a fibrous filter material having an average fibre denier in the range 7 to 9 and the second absorbent material 41, dispersed within the first absorbent material 40, comprises a fibrous filter material having an average fibre denier of below 7, for instance a denier of about from 1 to 6, 2 to 6, 3 to 6, or about 6, 5, 4 3, 2 or 1. The first and second fibrous filter materials 40, 41
20 comprise short length fibres which are randomly oriented in the filter.

The second filter segment 39 can be manufactured using the Turmalin apparatus, for instance by supplying a continuous tow of the first absorbent material 40 to the feeder 22 and by adding fibres of the second absorbent material via one of the additive hoppers in the filter bander 24. Alternatively, supplies of the first and
25 second filter materials 40, 41 can each be provided to the feeder 21 of the Turmalin apparatus, such that they are cut and randomised together and processed in a similar way to a single filter material.

30 The fibres of the first and second materials 40, 41 comprise discrete short length cellulose acetate fibres (as described herein) in the present example, although alternative fibres can also be used. For instance, the fibres of the first and/or second material can comprise cellulose acetate, polyvinyl alcohol (PVOH), polylactic acid (PLA), poly(ϵ -caprolactone)(PCL), poly(1-4 butanediol succinate)

(PBS), poly(butylene adipate-co-terephthalate)(PBAT), starch based materials, paper, aliphatic polyester materials and polysaccharide polymers or combinations therefore.

5 A further advantage is achievable through the use of nanofibre materials as a base for catalytic substances to enhance filter performance. Nanofibres have a sufficiently high surface area to volume ratio to have the potential for catalytic activity. Such nanofibres may be added to a filter using the apparatus of Figure 2, for instance at the time of additive loading through the one or more hoppers in the
10 filter bander 24 such that the nanofibres are metered into the airstream within the filter bander 24.

Figure 7 is a schematic illustration of a smoking article 51 having a filter including a nanofibre carrying an additive for enhancing or enabling the reduction of at least
15 one component of main stream smoke drawn through the smoking article 51 when in use.

Referring to Figure 7, the smoking article 51 comprises a tobacco rod 52 wrapped in a wrapping material 53, in this case cigarette paper, connected longitudinally to a
20 filter 54 by tipping material 55 overlaying the filter 54 and partially overlaying the wrapping material 53. The filter 54 comprises a first segment 56 at the mouth-end of the filter 54 comprising crimped cellulose acetate tow 57 wrapped in a first plug wrap 58, and a second segment 59 at the tobacco rod end of the filter 54 comprising nanofibres 60 wrapped in a second plug wrap 61. The first segment 56 is a cellulose
25 acetate segment formed using continuous cellulose acetate fibres and a plasticiser. In the present example the nanofibres 60 are short length randomly oriented fibres mixed with cellulose acetate short length randomly oriented fibres. The nanofibres comprise carbon nanofibres 60a supporting zinc oxide (ZnO) particles acting as a catalytic agent 60b, for instance enhancing the reduction of HCN in cigarette
30 smoke. In alternative embodiments, other nanofibre materials and/or other catalytic agents can be used, alone or in combination (including in combination with carbon and/or ZnO), such as Gold (Au), for instance for Carbon Monoxide (CO) reduction from cigarette smoke. The nanofibres 60 can be added as an additive to

randomly orientated staple length cellulose acetate fibres using the filter making apparatus 20 of Figure 2.

5 The nanofibres can be of any suitable length for inclusion in a filter segment, for instance between 1mm and 15mm, or from 5mm to 12mm. The diameters of the nanofibres used can be from 25nm to 900nm, or from 50nm to 500nm, or from 100nm to 300nm.

10 In further embodiments of the invention, where local regulations permit, flavour may be provided to filters produced using the Turmalin apparatus.

The addition of flavour to a filter can be achieved using a thread as a carrier. An example of suitable apparatus for inserting threads into filter material is provided in patent publication no.WO2010/108739 and corresponding U.S. patent application
15 publication of U.S. application serial no. 13/259,634, the contents of which are incorporated by reference herein. A Thread insertion device, such as that described in WO2010/108739, can be installed in a central portion of the filter vacuum band with a thread inserting needle carrying the thread into the axial region of the filter rod as it is formed. Embodiments described herein involving the insertion of
20 threads into filters are particularly advantageous in slim and super slim formats, i.e. below 22mm diameters, and in particular below 21mm, 20mm, 18mm, 16mm, 15mm and 14mm.

25 Figure 8 is a schematic illustration of a smoking article having a filter comprising randomly oriented discrete short length fibres having a thread extending therethrough.

Referring to Figure 8, the smoking article 151 comprises a tobacco rod 152 wrapped in a wrapping material 153, in this case cigarette paper, connected longitudinally to a
30 filter 154 by tipping material 155 overlaying the filter 154 and partially overlaying the wrapping material 153. The filter 154 comprises a first segment 156 at the mouth-end of the filter 154 comprising crimped cellulose acetate tow 157 wrapped in a first plug wrap 158, and a second segment 159 at the tobacco rod end of the

filter 154 comprising absorbent material 160. A thread 161 extends axially through the second segment 159. The second segment 159 is wrapped in a second plug wrap 162. In the present example the absorbent material 160 comprises randomly oriented discrete short length cellulose acetate fibres.

5

The inventors have also appreciated that the Turmalin apparatus, or similar, may be arranged to permit the inclusion into randomly oriented discrete short length fibre filters of capsules, microcapsules or other encapsulated material, while ensuring uniform distribution of the capsule contents, such as flavour (where local regulations permit) or diluents.

10

In a similar manner as described in relation to carbon loading, it is possible to add such materials at higher levels in order to deliver more flavour. Capsules, whether larger capsules such as those with diameters between 3mm and 8mm, microcapsules or other encapsulated materials, can be pushed into filter tow in an apparatus such as the Turmalin apparatus by directing the capsules through a tube into the filter tow at the downstream end of the filter bander. The capsules can, for instance, be blown into the filter material using high pressure gas, at a frequency corresponding to the speed of the filter bander, such that capsules are located in the resulting filter rod at appropriate intervals, and filter segments cut from the filter rod contain the desired number of capsules. Alternatively, microcapsules could be metered onto the filter band in a similar way to additives, using one of the additive hoppers described above. Embodiments described herein involving the insertion of encapsulated flavourants into filters are particularly advantageous in slim and super slim formats, i.e. below 22mm diameters, and in particular below 21mm, 20mm, 18mm, 16mm, 15mm and 14mm.

15

20

25

Figure 9 is a schematic illustration of a smoking article 171 having a filter comprising randomly oriented discrete short length fibres having a capsule disposed therein. Referring to Figure 9, the smoking article 171 comprises a tobacco rod 172 wrapped in a wrapping material 173, in this case cigarette paper, connected longitudinally to a filter 174 by tipping material 175 overlaying the filter 174 and partially overlaying the wrapping material 173. The filter 174 comprises a first

30

segment 176 at the mouth-end of the filter 174 comprising crimped cellulose acetate tow 177 wrapped in a first plug wrap 178, and a second segment 179 at the tobacco rod end of the filter 174 comprising absorbent material 180. An encapsulated flavourant 181, in the present case in the form of a capsule, is disposed within
5 second segment 179. The second segment 179 is wrapped in a second plug wrap 182. In the present example the absorbent material 180 comprises randomly oriented discrete short length cellulose acetate fibres.

Figure 10 is a schematic illustration of a smoking article having a filter comprising
10 randomly oriented discrete short length fibres having microcapsules disposed therein.

Referring to Figure 10, the smoking article 191 comprises a tobacco rod 192 wrapped in a wrapping material 193, in this case cigarette paper, connected
15 longitudinally to a filter 194 by tipping material 195 overlaying the filter 194 and partially overlaying the wrapping material 193. The filter 194 comprises a first segment 196 at the mouth-end of the filter 194 comprising crimped cellulose acetate tow 197 wrapped in a first plug wrap 198, and a second segment 199 at the tobacco rod end of the filter 194 comprising absorbent material 200. Encapsulated
20 flavourant 201, in the present case in the form of a plurality of microcapsules, is disposed within second segment 199. The second segment 199 is wrapped in a second plug wrap 202. In the present example the absorbent material 200 comprises randomly oriented discrete short length cellulose acetate fibres.

25 In addition to encapsulated flavourants, other forms of flavour additive (where local regulations permit the use of such additives) can be added to a filter comprising randomly oriented discrete short length fibres. For instance, flavour additives could be added in botanical form, such as mint or tobacco leaves or other plant leaves, plant seeds, plant peel etc. Such additives can be added to the additive hoppers in
30 the band former of the Turmalin apparatus and therefore metered into the filter material air stream as the filter band is formed, for instance using discrete short length cellulose acetate fibres as described herein. Since no plasticiser is used in the

randomly oriented discrete short length fibre filter, flavour release from botanical additives can be enhanced.

It is envisaged by the inventors that additional materials not previously used in filter
5 manufacturing may be used in manufacture using a Turmalin apparatus or similar.

In one embodiment, shredded sheet materials, including new sheet materials, are included within the filter material. Such sheet materials include sheet materials formed from botanicals, such as mint and or menthol, tobacco or reconstituted
10 tobacco. A person skilled in the art will appreciate that the list provided is not limiting and that any suitable sheet material may be used. The benefits of using such sheet materials in shredded form are that they can improve the dispersibility of the material within the filter and also improve the degradability of the filter material. Furthermore, the use of new materials may be used to improve the performance of
15 the filter and/or modify characteristics of smoke drawn through the filter.

Figure 11 is a schematic illustration of a smoking article having a filter comprising randomly oriented discrete short length fibres having shredded sheet material disposed therein.

20 Referring to Figure 11, the smoking article 211 comprises a tobacco rod 212 wrapped in a wrapping material 213, in this case cigarette paper, connected longitudinally to a filter 214 by tipping material 215 overlaying the filter 214 and partially overlaying the wrapping material 213. The filter 214 comprises a first
25 segment 216 at the mouth-end of the filter 214 comprising crimped cellulose acetate tow 217 wrapped in a first plug wrap 218, and a second segment 219 at the tobacco rod end of the filter 214 comprising absorbent material 220 in which shredded sheet material 221 is dispersed. The second segment 219 is wrapped in a second plug wrap 222. In the present example the absorbent material 200 comprises randomly
30 oriented discrete short length cellulose acetate fibres and the shredded sheet material 221 comprises shredded reconstituted tobacco sheet.

The shredded sheet material 221 can comprise a material formed from fibres of

cellulose acetate, polyvinyl alcohol (PVOH), polylactic acid (PLA), poly(ϵ -caprolactone)(PCL), poly(1-4 butanediol succinate) (PBS), poly(butylene adipate-co-terephthalate)(PBAT), starch based materials, paper, aliphatic polyester materials or polysaccharide polymers and/or combinations therefore.

5

The inventors have also appreciated the potential for combining degradable or otherwise alternative fibres such as PVOH fibres with conventional cellulose acetate fibres. PVOH is typically not used in conventional filter manufacture because PVOH cannot usually be crimped. The inclusion of PVOH or other non-crimped fibres with another material, i.e. cellulose acetate, mean that this problem can be overcome. Using such materials can result in a filter with improved degradability and water solubility. Other materials include poly(ϵ -caprolactone)(PCL), poly(1-4 butanediol succinate)(PBS), poly(butylene adipate-co-terephthalate)(PBAT), starch based materials, paper, aliphatic polyester materials and polysaccharide polymers.

10

Also, other crimped materials such as PLA can be combined with conventional cellulose acetate fibres.

In one embodiment, in order to add PVOH or other non-crimped fibres to a filter, or PLA or other crimped fibres to a filter, the Turmalin feeder 22 is arranged to feed two ropes of raw filter material into the cutter and randomiser 23. As such, the number of processing steps is reduced by not first turning the material into sheet material, and instead pulling the material straight in as tow.

25 In addition, the number processing steps may be further reduced if the step for turning material into tow material is omitted. In such embodiments, there is further no requirement to feed, cut and randomise the fibres. Rather, the PVOH, PLA or other material in raw fibrous form can be mixed directly with a bag of short staple cellulose acetate fibres lanced straight into the Turmalin apparatus.

30

In another embodiment, PVOH fibres (or other non-crimped fibres) or PLA fibres (or other crimped fibres) can be metered into the filter tow in the filter bander 24 using one of the additive hoppers described above.

Figure 12 is a schematic illustration of a smoking article having a filter comprising randomly oriented discrete short length fibres having degradable fibres disposed therein. Referring to Figure 12, the smoking article 231 comprises a tobacco rod 232 wrapped in a wrapping material 233, in this case cigarette paper, connected
5 longitudinally to a filter 234 by tipping material 235 overlaying the filter 234 and partially overlaying the wrapping material 233. The filter 234 comprises a first segment 236 at the mouth-end of the filter 234 comprising crimped cellulose acetate tow 237 wrapped in a first plug wrap 238, and a second segment 239 at the tobacco
10 rod end of the filter 234 comprising absorbent material 240 in which PVOH fibres 241 are dispersed. The second segment 239 is wrapped in a second plug wrap 242. In the present example the absorbent material 240 comprises randomly oriented discrete short length cellulose acetate fibres.

15 Conventional filter manufacturing techniques manufacture filter rods with a uniform density in a longitudinal direction. The inventors have appreciated that it is possible to purposely provide variable density along the length of the filter rod. In one embodiment the density may be caused to vary such that when the filter rod is cut into individual segments, the filter segment comprises dense ends, and a centre
20 portion of lower density. This is advantageous as it does not rely on the tow crimp to hold fibres in the filter.

Figure 13a is a schematic illustration of a filter rod 245 comprising alternately arranged longitudinal regions 246 of higher average density and regions 247 of
25 lower average density. The filter rod 245 can be used to produce multiple filter segments, each comprising a homogeneous unit of filter material, for instance varying only in density along its length, for use in smoking article filters. For instance, the filter rod 245 can be cut at the centre 248 of each of the regions 246 of higher average density such that the resulting filter segments have 'dense ends'.
30 Line graph 249 illustrates the density of filter material along the length of the filter rod 245, in the present example varying in an undulating or sinusoidal manner. In alternative examples, the density of filter material along the length of the filter rod 245 can vary in other ways, for instance in a sequence of 1, 2, 3, 4 or more stepped

variations in the density for each density cycle along the length of the filter rod 245. The filter material illustrated in Figure 13a comprises discrete short length cellulose acetate fibres, but can alternatively be another fibrous filter material described herein, such as polyvinyl alcohol (PVOH), polylactic acid (PLA), poly(ϵ -
5 caprolactone)(PCL), poly(1-4 butanediol succinate) (PBS), poly(butylene adipate-co-terephthalate)(PBAT), starch based materials, paper, aliphatic polyester materials and polysaccharide polymers or combinations therefore. The material can also contain additives, such as adsorbents as herein described.

10 The denser portions, as shown in Figure 13a, are such that the fibres, even if some or all of the fibres are not crimped, are prevented from spilling out of filter segments, once cut. The embodiment of Figure 13a accordingly can enable the use of materials which are not suitable for crimping, for example PVOH and non-woven materials. This, in turn, can lead to increased degradability and water
15 solubility as described above. The filter material can therefore be formed from a single fibrous material, or multiple combined materials such as cellulose acetate fibres combined with those of another material.

A person skilled in the art will appreciate different ways in which the density of the
20 filter rod 245 may be caused to vary along its length. For example, this could be achieved by using machinery having a variable speed garniture or pulsing higher volumes of filter material, or additives, when forming filter material onto a suction band. Alternatively or in addition, the filter suction band can be adapted to enable regions of higher average density and regions of lower average density to be formed
25 on the band, for instance by varying the air resistance of the band in different regions such as by varying the size and/or frequency of apertures on the band according to the desired density pattern. The timing of the production line can be controlled such that the segment lengths are controlled and cut accordingly.

30 Figure 13b is a schematic illustration of a section of a filter forming suction band, such as that used in the filter bander 24 of the Turmalin apparatus, for producing filter segments having regions of higher average density and regions of lower average density. Referring to Figure 13b, the filter forming suction band 250

comprises a nylon mesh 251 formed so as to have first regions 252 having larger mesh apertures and a lower density of mesh material and second regions 253 having smaller mesh apertures and a higher density of mesh material. The first regions 252 accordingly have a lower resistance to air than the second regions 253. In use, the
5 fibres in the filter bander air stream will be drawn towards the first regions 252 having larger mesh apertures with greater force than towards the second regions 253 having smaller mesh apertures. As a result, a greater average density of filter fibres will be deposited in the first regions 252 than in the second regions 253. The resulting filter will therefore have regions of greater average density corresponding
10 to the first regions 252 of the suction band 250 and regions of lower average density corresponding to the second regions 253 of the suction band 250.

In the example of Figure 13b, the size and number of apertures is varied along the length of the suction band 250 in an undulating manner. However, in other
15 embodiments, only the size of the apertures can be varied along the length of the suction band, for instance by using a solid band with varying aperture sizes cut into the band at different longitudinally spaced repeating intervals. Alternatively, in other embodiments, only the number of apertures is varied along the length of the suction band, for instance by using a solid band with varying numbers of apertures
20 for a given area of band cut into the band at different longitudinally spaced repeating intervals along the band. Also, rather than following an undulating variation in air resistance along the length of the suction band, the apertures can be arranged such that 1, 2, 3, 4 or more step changes in the density of filter material occur in repeating intervals along the length of the band.

25 The inventors have also realised that it is possible to create filters having a non-conventional cross-sections. In conventional filter rods, if a non-circular shape was desired it would require a substantial quantity of plasticiser and steam to form the required shape. In practice this has not been readily achievable. However, the
30 inventors have appreciated that the way in which the Turmalin apparatus creates an oblong band which has a mechanical strength can be adapted for other cross-sectional shapes of the filter material. For instance, the Turmalin apparatus could be adapted to create a band other than an oblong or the filter material can be forced

into a desired shape, for instance via a shaped aperture or using an appropriately shaped garniture belt. For example, the band of filter material may be formed on the belt of the filter bander 24 or passed through an appropriately shaped aperture or garniture belt, such that the filter has a polygonal, for instance triangular, square, 5 rectangular, pentagonal or hexagonal cross-section, or another non-circular cross-section, such as an oval or elliptical cross-section, and the structural stability of the band of material can be such that the band maintains the desired shape. Another embodiment may make use of appropriately designed wrapping and steaming processes. The resulting filter may have a cross section with a circumference 10 smaller than 16mm or a circumference greater than 25mm.

Figure 14 is a schematic illustration of a smoking article 291 having a filter comprising an elliptical cross-section.

15 Referring to Figure 14, the smoking article 291 comprises an elliptically cross-sectioned tobacco rod 292 wrapped in a wrapping material 293, in this case cigarette paper, connected longitudinally to a filter 294 by tipping material 295 overlaying the filter 294 and partially overlaying the wrapping material 293. The filter 294 20 comprises a single filter segment 296 at the mouth-end of the smoking article 291 comprising absorbent material 297 wrapped in a first plug wrap 2980. The segment 296 has an elliptical cross-section. In the present example the absorbent material 297 comprises randomly oriented discrete short length cellulose acetate fibres. An additional plastic mesh, a fabric, or other permeable barrier (not shown) can be applied across the mouth-end of the filter 294 to prevent individual filter fibres 25 from coming away from the filter 294.

Figure 15 is a schematic illustration of a smoking article 311 having a filter comprising a square cross-section.

30 Referring to Figure 15, the smoking article 311 comprises a square cross-sectioned tobacco rod 312 wrapped in a wrapping material 313, in this case cigarette paper, connected longitudinally to a filter 314 by tipping material 315 overlaying the filter 314 and partially overlaying the wrapping material 313. The filter 314 comprises a

single segment 316 at the mouth-end of the smoking article 311 comprising absorbent material 317 wrapped in a plug wrap 318. The segment 316 has a square cross-section. In the present example the absorbent material 317, 320 comprises randomly oriented discrete short length cellulose acetate fibres. An additional
5 plastic mesh, a fabric, or other permeable barrier (not shown) can be applied across the mouth-end of the filter 314 to prevent individual filter fibres from coming away from the filter 314.

The filters 294, 314 of the embodiments illustrated in Figures 14 and 15 can also
10 include other features, such as additives dispersed within the filter fibres and/or ventilation applied to the filters, for instance as laser formed holes.

The inventors have also realised that it is possible to produce filters including randomly orientated short-length fibres formed into a cylinder having a
15 circumference smaller than 16mm, 15mm, 14mm or 13mm, or a circumference greater than 25mm, 26mm, 27mm or 28mm. A single denier fibre can be used, for instance having a denier from about 7 to about 9, and the amount used in the filter per mm varied according to the filter circumference required. For instance, the amount of randomly orientated short-length fibres per mm can be reduced for super
20 slim format filters and increased for regular format filters. This differs from known continuous tow filter manufacture where different fibre deniers are usually required for different circumference filters.

In the foregoing examples, the second filter segments 9, 39, 59, 159, 179, 199, 219
25 and 239 (shown in Figures 1 and 6 to 12) containing randomly oriented discrete length fibres have been described as tobacco-end components of dual filters, with known cellulose acetate first filter segments at the mouth-end. However, other arrangements are possible. For instance, the second segments can be adapted for use at the mouth end of cigarette filters. This can be achieved by preventing
30 individual fibres from coming away from the filter segment during use, for instance by including a plasticiser (for instance a localised plasticiser in a portion at the mouth end of the mouth-end segment) to hold the randomly oriented discrete length fibres and/or any additives dispersed therein in place, or by using a plastic

mesh, a fabric, or other permeable barrier preventing individual fibres from reaching the mouth of a consumer. The second filter segments can also be used as the central or tobacco-end filter segment of a three-part filter, or any segment of a four, five or six-part filter, as required. The first filter segments can also be other
5 than conventional cellulose acetate segments wrapped in plug wrap. For instance, non-wrapped acetate (NWA) sections can be used as the first filter segments described herein.

Also, the first and second filter segments of the embodiments illustrated in Figures
10 1 and 6 to 12 have been shown to have individual plug wraps and be held together and connected to the tobacco rod using a tipping material. However, alternatively, a further outer plug wrap (not shown) can be wrapped around the first and second filter segments and used to connect the first and second filter segments to each other, and the combined filter unit can then be connected to the tobacco rod using
15 a tipping material.

Although the randomly oriented fibres described herein have been described as being crimped, non-crimped fibres can also be used, alone or mixed with crimped fibres. Also, the randomly oriented fibres have been described as being of 10mm
20 fibre lengths (when extended), or lengths in the range from 5mm to 25mm, or from 6mm to 20mm, 7mm to 20mm or 7mm to 15mm. The second segments can also include average fibre lengths outside this range, and/or mixtures of groups fibres of different average lengths, depending on the requirement of the filter concerned and the fibrous materials available.

25 Filter arrangements described herein can be modified to include one or more transparent sections in the plug wrap and/or tipping paper so as to allow the internal filter parts to be seen by smoking article consumers. For instance, the second plug wrap used to wrap the second filter segment may comprise a
30 transparent material such as Natureflex™ film available from Innovia Films in the United Kingdom. The tipping could comprise one or more window cut-outs, or sections of transparent material such as Natureflex™ film, to enable the internal filter parts to be seen through the tipping and plug wrap. Alternatively, the tipping

could be applied in two bands with a gap between them revealing the transparent plug wrap beneath, or the tipping could be made entirely of a material such as Natureflex™ film. Some embodiments may include transparent 'window' section filters such as those described in patent publication no. WO2009/106374, the
5 contents of which (including any corresponding US publications) are incorporated by reference in their entirety herein.

In order to address various issues and advance the art, the entirety of this disclosure shows by way of illustration various embodiments in which the claimed invention(s)
10 may be practiced and provide for superior smoking article filters. The advantages and features of the disclosure are of a representative sample of embodiments only, and are not exhaustive and/or exclusive. They are presented only to assist in understanding and teach the claimed features. It is to be understood that advantages, embodiments, examples, functions, features, structures, and/or other
15 aspects of the disclosure are not to be considered limitations on the disclosure as defined by the claims or limitations on equivalents to the claims, and that other embodiments may be utilised and modifications may be made without departing from the scope and/or spirit of the disclosure. Various embodiments may suitably comprise, consist of, or consist essentially of, various combinations of the disclosed
20 elements, components, features, parts, steps, means, etc. In addition, the disclosure includes other inventions not presently claimed, but which may be claimed in future.

Claims

1. A filter for a smoking article comprising randomly oriented short length fibres and a flavour release component.
5
2. A filter according to claim 1, having a cylindrical shape and an overall circumference of less than about 22mm.
3. A filter according to claim 2, having an overall circumference of less than
10 about 21mm, 20mm, 18mm, 16mm, 15mm or 14mm.
4. A filter according to claim 1, 2 or 3, wherein the flavour release component comprises a thread extending longitudinally through at least a portion of the filter.
- 15 5. A filter according to any one of claims 1 to 3, wherein the flavour release component comprises encapsulated flavourant.
6. A filter according to claim 5, wherein the flavour release component comprises one or more capsules or microcapsules.
20
7. A filter according to claim 6, wherein the flavour release component comprises one or more capsules having a diameter of between 3 and 8mm.
8. A filter according to any one of the preceding claims, wherein the flavour
25 release component comprises a botanical additive.
9. A filter according to any one of the preceding claims, further comprising an adsorbent material dispersed within an absorbent material, wherein the amount of adsorbent material in mg, C_w , per mm in length, and the amount of absorbent
30 material in mg, T_w , per mm in length, for a filter circumference of about 23 to 25 mm, are in accordance with the range:

$$10 \leq (C_w + T_w) \leq 20.$$

10. A filter according to any preceding claim, wherein the randomly oriented short length fibres are held together in the filter without the use of a plasticiser.
11. A filter according to any preceding claim, wherein the randomly oriented
5 short length fibres comprise a first fibrous filter material having an average fibre denier in the range 7 to 9 and a second fibrous filter material having an average fibre denier of below 7, wherein the second fibrous filter material is dispersed within the first fibrous filter material.
- 10 12. A filter according to claim 11, wherein the second fibrous filter material has an average fibre denier in the range from 1 to 6.
13. A filter according to any preceding claim, wherein the randomly oriented short length fibres comprise fibres having an average length of from about 5mm to
15 20mm when extended.
14. A filter according to any preceding claim, comprising randomly oriented short length fibres formed from a first material and randomly oriented short length fibres formed from a second material.
- 20 15. A filter according to any preceding claim, wherein the randomly orientated short-length fibres are formed into a shape other than a cylinder or formed into a cylinder having a circumference greater than 25mm.
- 25 16. A smoking article comprising a filter according to any one of the preceding claims.

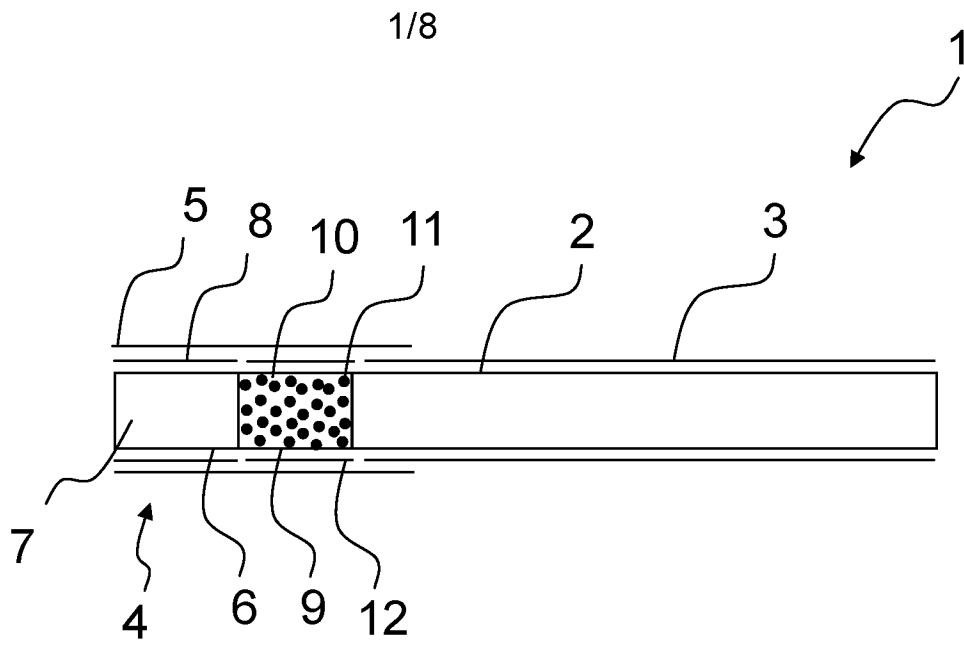

Figure 1

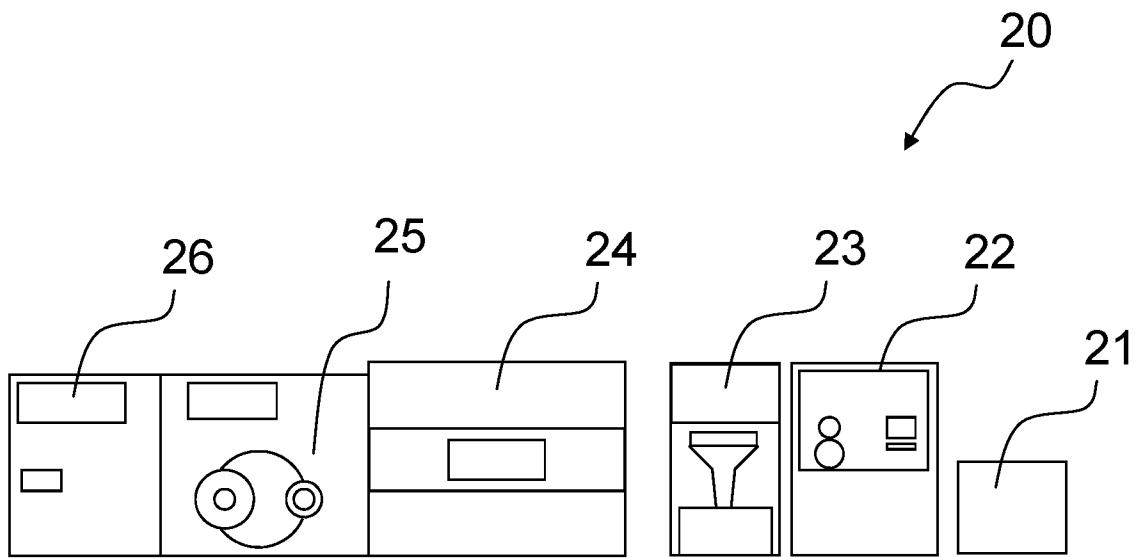

Figure 2

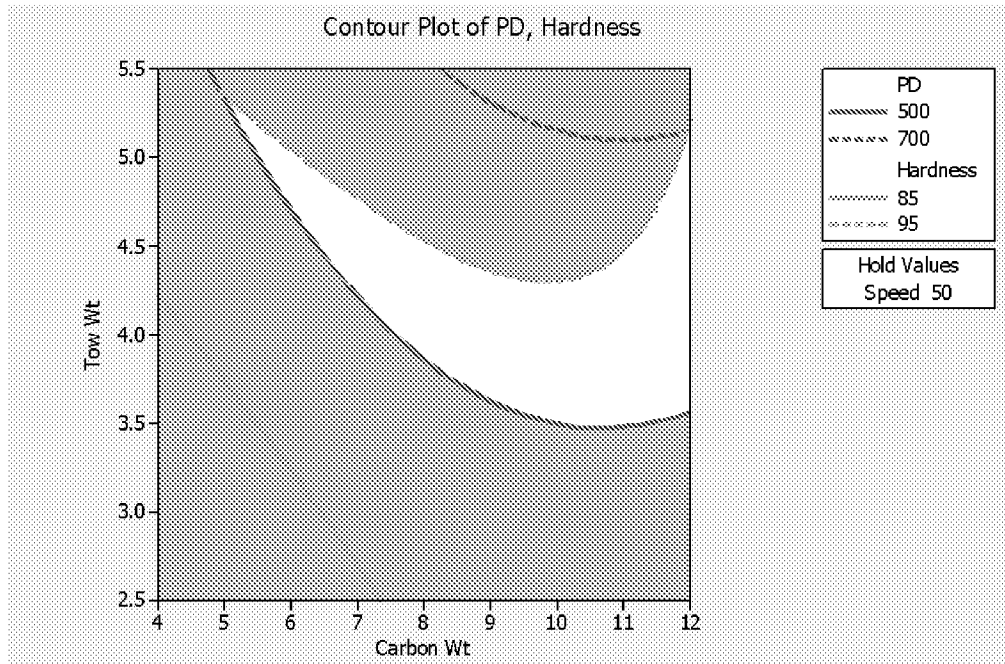

Figure 3

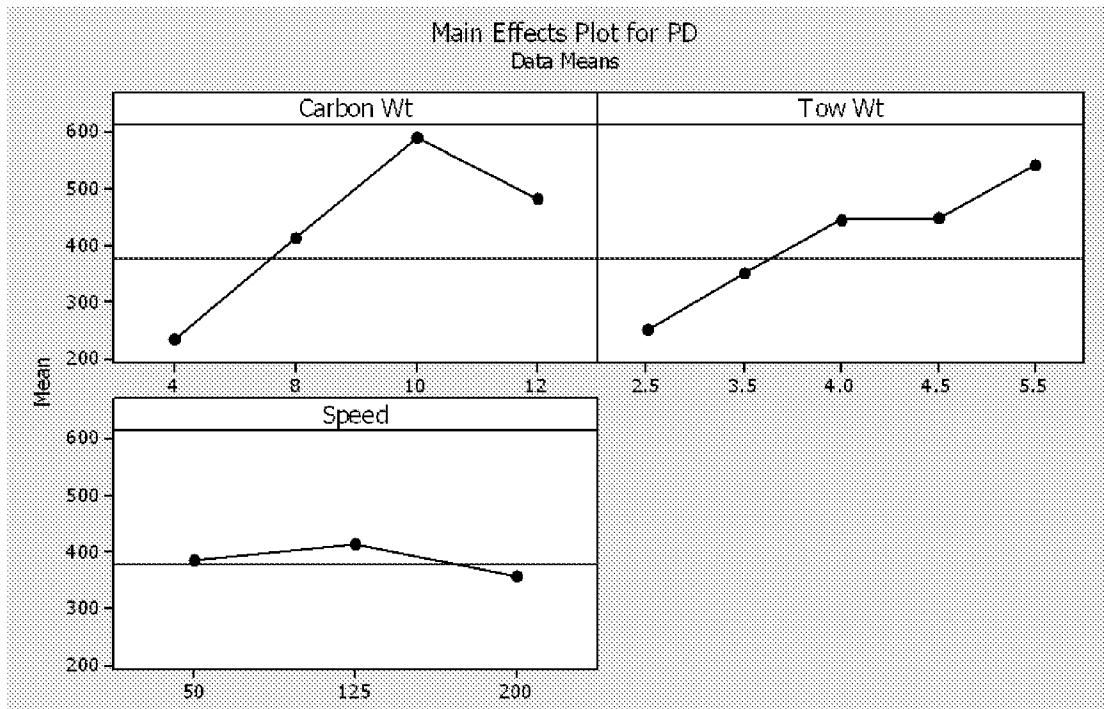

Figure 4

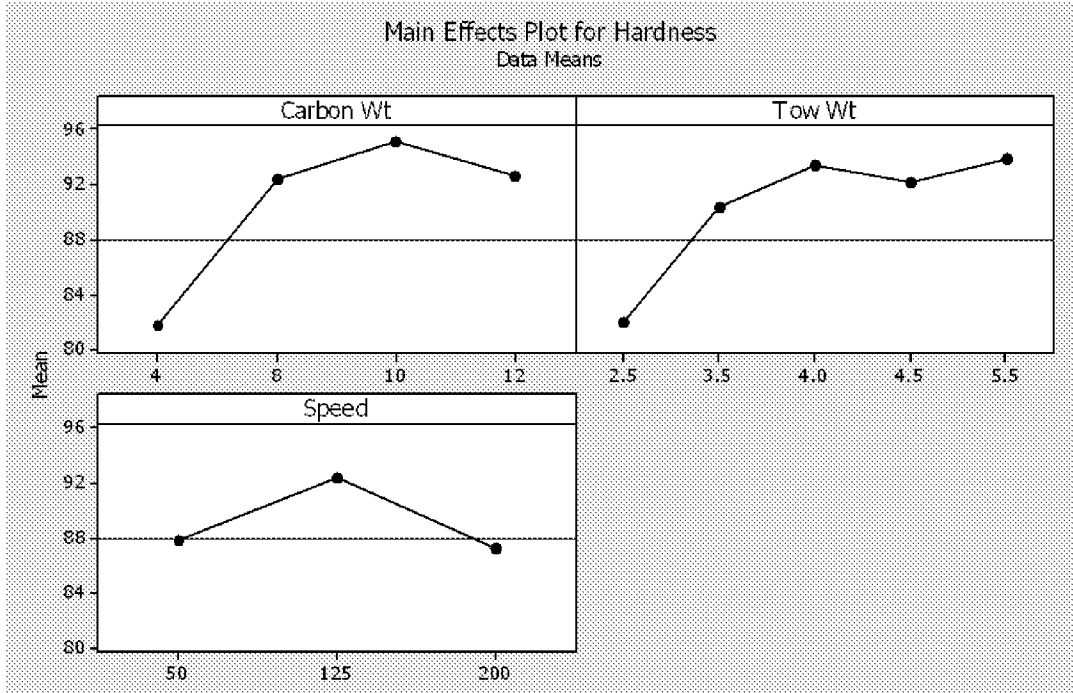

Figure 5

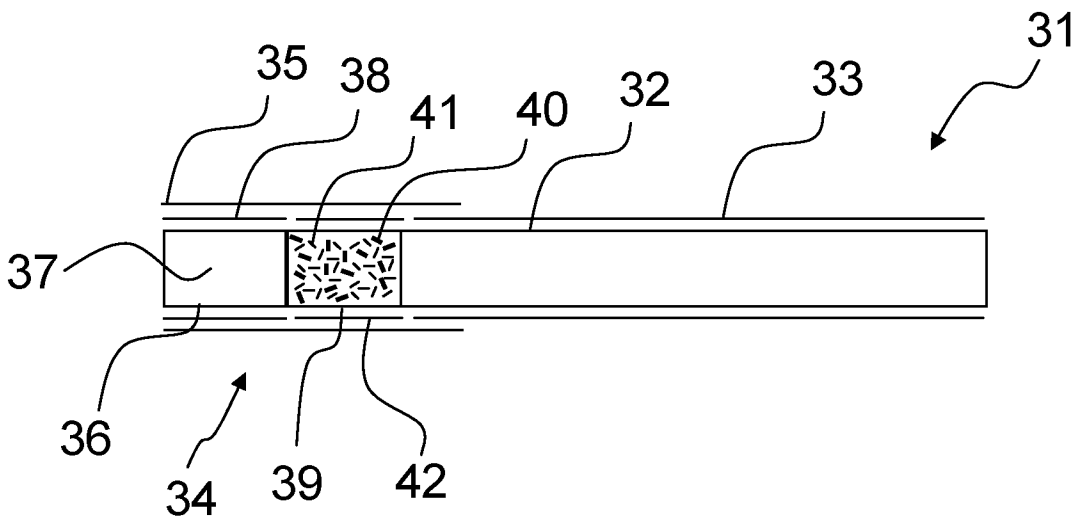

Figure 6

4/8

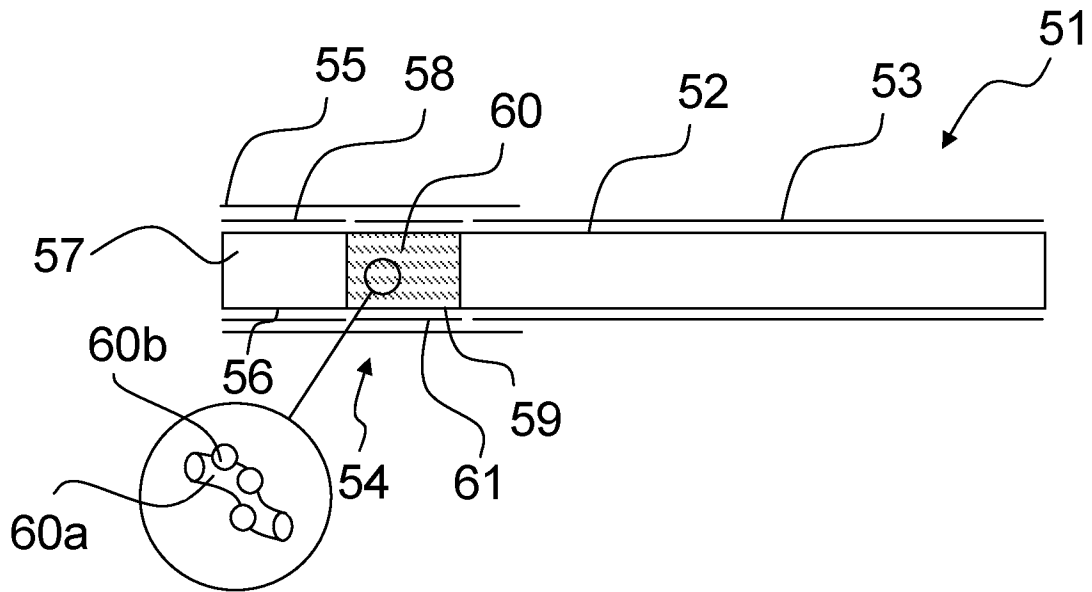

Figure 7

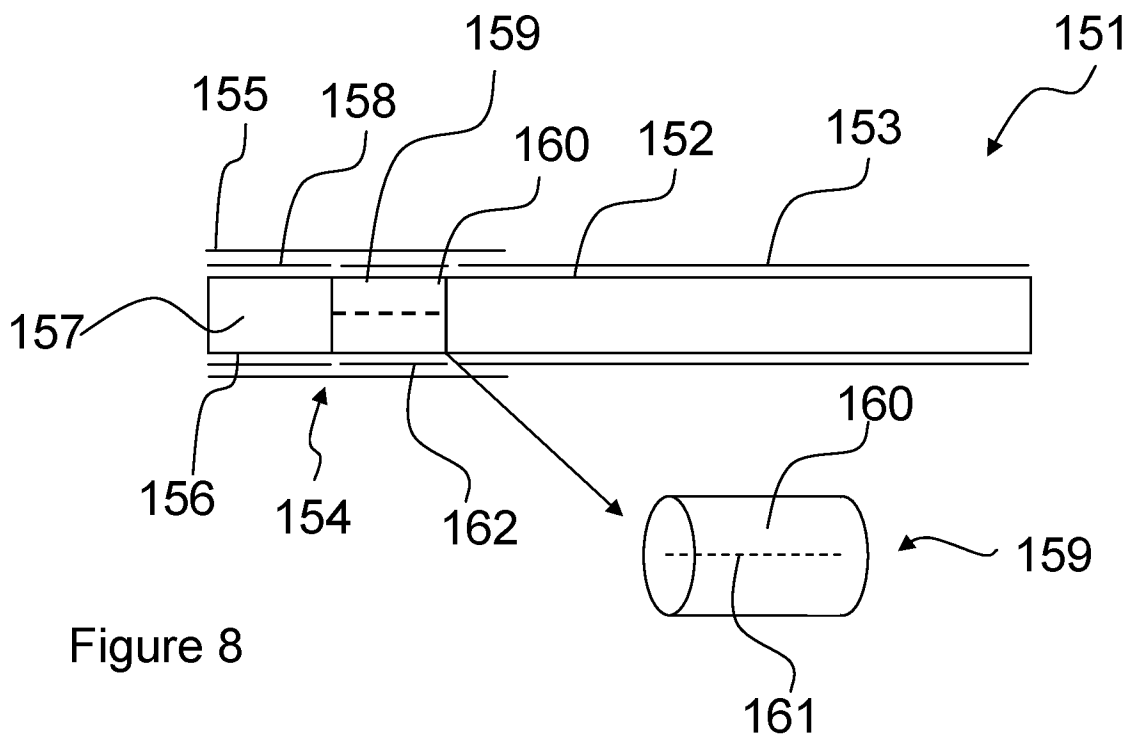

Figure 8

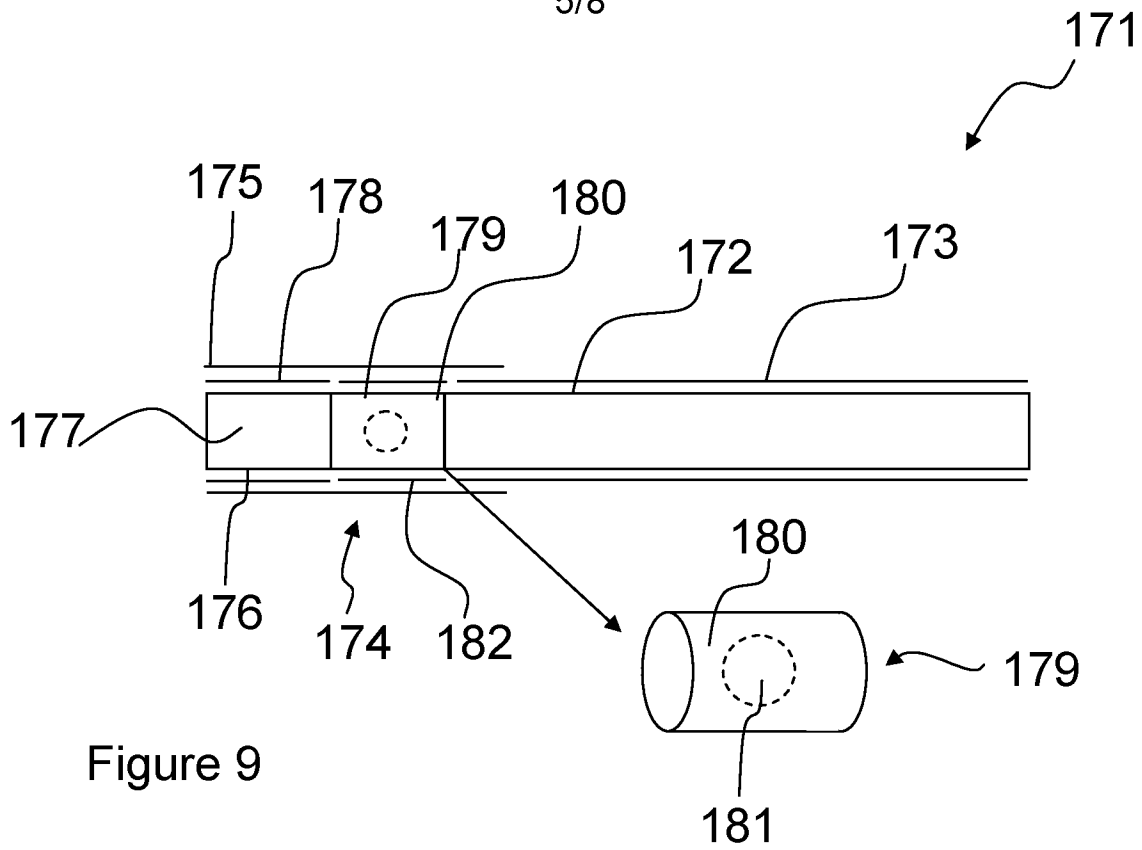

Figure 9

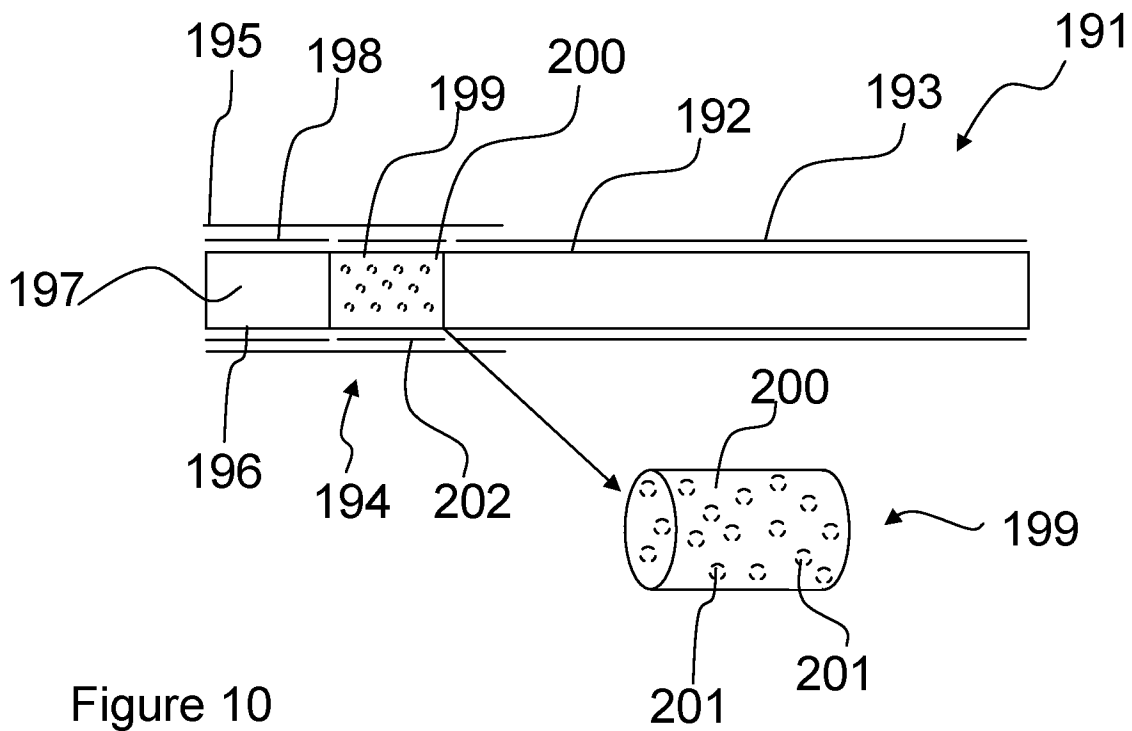

Figure 10

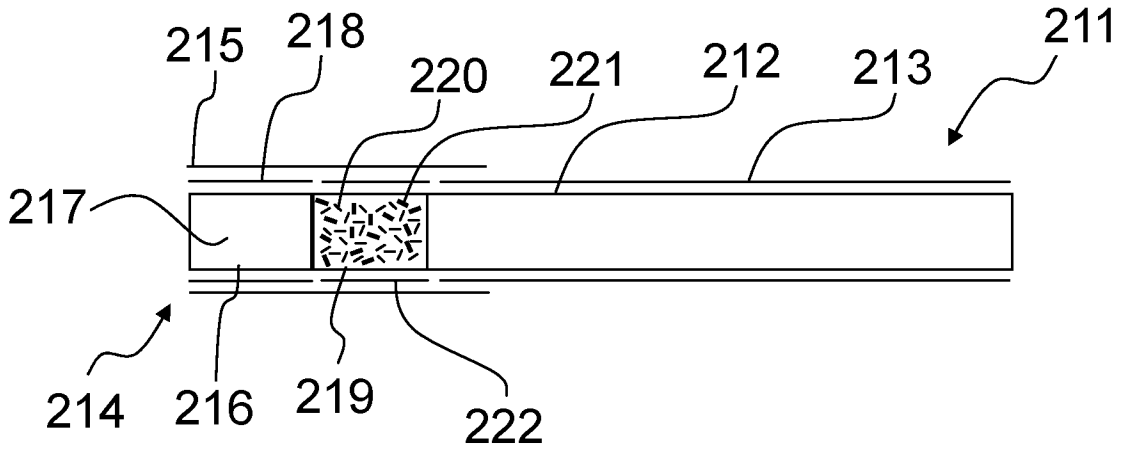

Figure 11

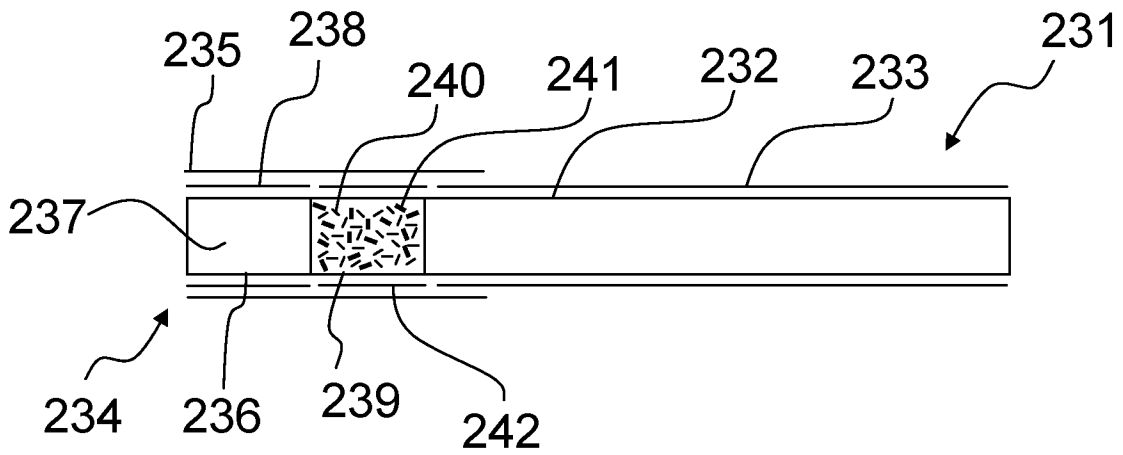

Figure 12

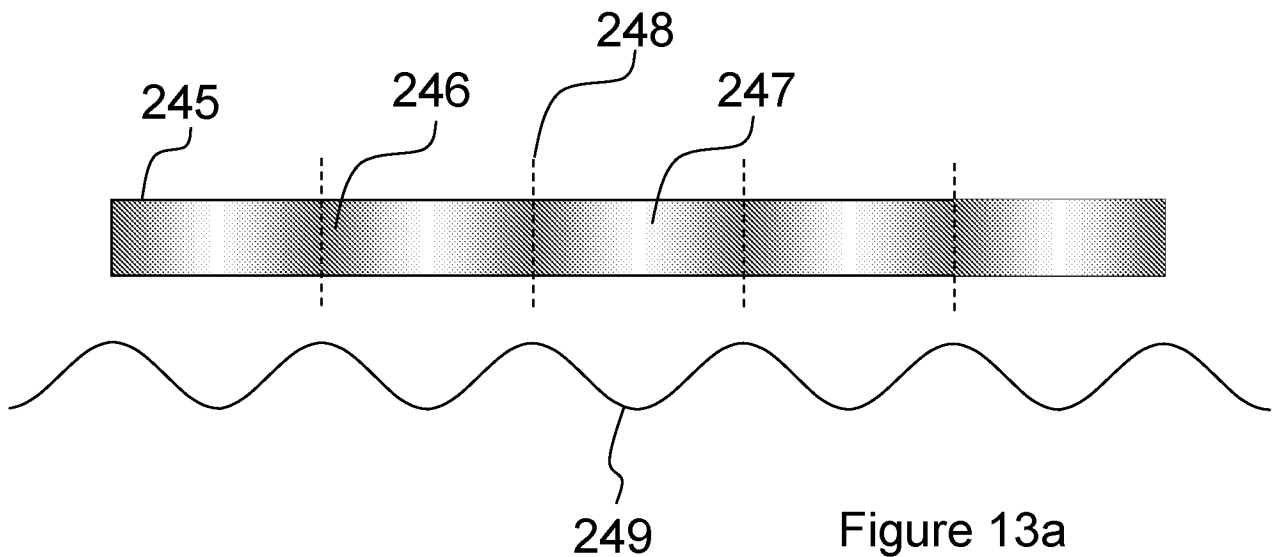

Figure 13a

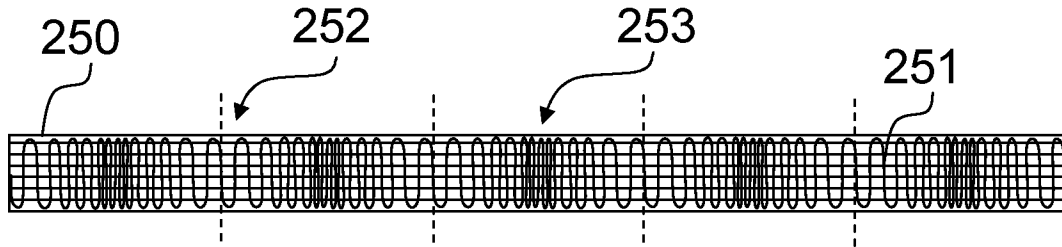

Figure 13b

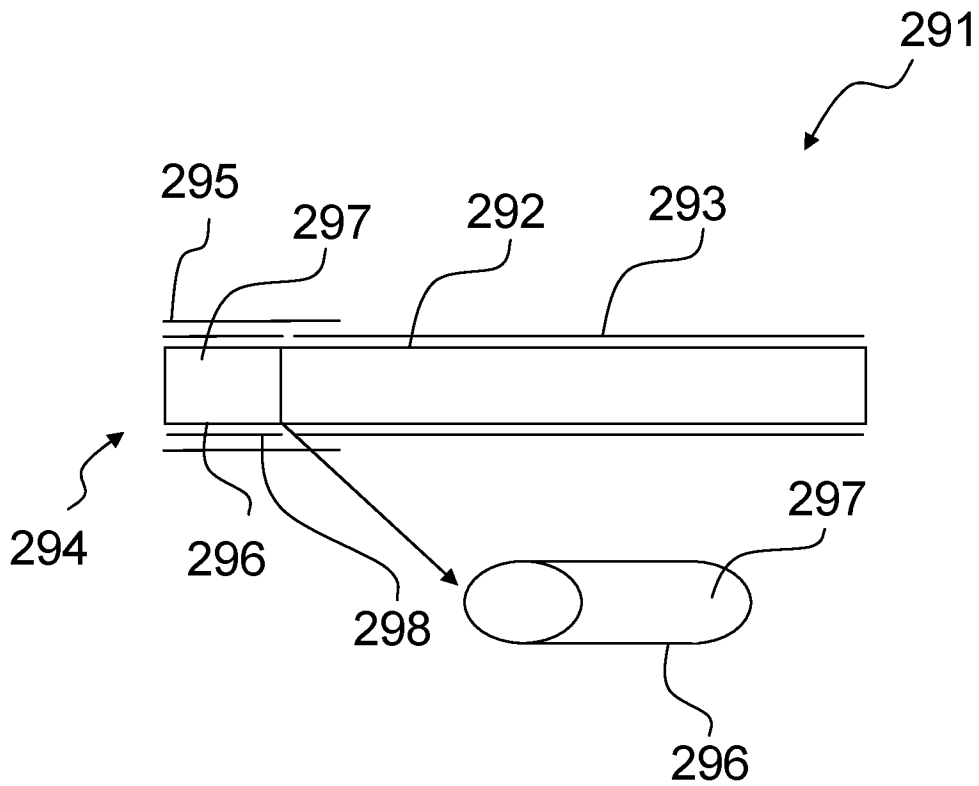

Figure 14

8/8

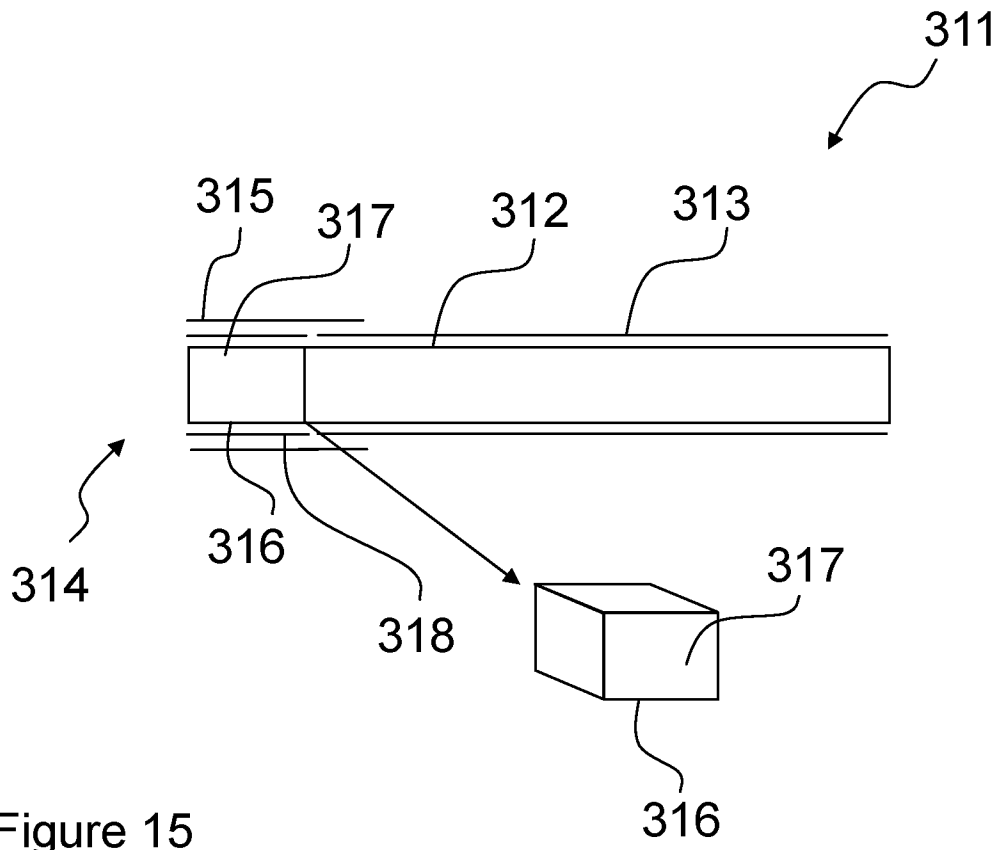

Figure 15

INTERNATIONAL SEARCH REPORT

International application No
PCT/GB2013/051138

A. CLASSIFICATION OF SUBJECT MATTER
INV. A24D3/04 A24D3/06 A24D3/10 A24D3/16
ADD.
According to International Patent Classification (IPC) or to both national classification and IPC

B. FIELDS SEARCHED
Minimum documentation searched (classification system followed by classification symbols)
A24D

Documentation searched other than minimum documentation to the extent that such documents are included in the fields searched

Electronic data base consulted during the international search (name of data base and, where practicable, search terms used)
EPO-Internal, WPI Data

C. DOCUMENTS CONSIDERED TO BE RELEVANT

Category*	Citation of document, with indication, where appropriate, of the relevant passages	Relevant to claim No.
X	WO 2009/093051 A2 (FILTRONA INT LTD [GB]; CLARKE PAUL FRANCIS [GB]; ARAUJO DANIEL S [PY]) 30 July 2009 (2009-07-30) cited in the application	1-3,5-16
Y	page 1, line 4 - line 11 page 2, line 24 - line 29 page 3, line 4 - line 6 page 5, line 15 - line 18 page 5, line 23 - line 25 page 6, line 11 - line 19 page 7, line 3 - line 6	4
X	EP 2 401 929 A1 (PHILIP MORRIS PROD [CH]) 4 January 2012 (2012-01-04)	1-3,5-9, 11-13, 15,16
Y	column 2, line 20 - line 35 figures 2, 4, 6, 8 claims 3, 4	4
	----- -/--	

Further documents are listed in the continuation of Box C.

See patent family annex.

* Special categories of cited documents :

- "A" document defining the general state of the art which is not considered to be of particular relevance
- "E" earlier application or patent but published on or after the international filing date
- "L" document which may throw doubts on priority claim(s) or which is cited to establish the publication date of another citation or other special reason (as specified)
- "O" document referring to an oral disclosure, use, exhibition or other means
- "P" document published prior to the international filing date but later than the priority date claimed

- "T" later document published after the international filing date or priority date and not in conflict with the application but cited to understand the principle or theory underlying the invention
- "X" document of particular relevance; the claimed invention cannot be considered novel or cannot be considered to involve an inventive step when the document is taken alone
- "Y" document of particular relevance; the claimed invention cannot be considered to involve an inventive step when the document is combined with one or more other such documents, such combination being obvious to a person skilled in the art
- "&" document member of the same patent family

Date of the actual completion of the international search 30 September 2013	Date of mailing of the international search report 08/10/2013
---	---

Name and mailing address of the ISA/ European Patent Office, P.B. 5818 Patentlaan 2 NL - 2280 HV Rijswijk Tel. (+31-70) 340-2040, Fax: (+31-70) 340-3016	Authorized officer Dimoula, Kerasina
--	--

INTERNATIONAL SEARCH REPORT

International application No
PCT/GB2013/051138

C(Continuation). DOCUMENTS CONSIDERED TO BE RELEVANT		
Category*	Citation of document, with indication, where appropriate, of the relevant passages	Relevant to claim No.
X	US 3 444 863 A (SOEHNGEN JOHN WILLIAM ET AL) 20 May 1969 (1969-05-20)	1-3,5-8, 11-13, 15,16
Y A	column 5, line 63 - column 6, line 70; figure 2	4 9,14
X	US 2008/314400 A1 (YANG SZU-SUNG [US] ET AL) 25 December 2008 (2008-12-25)	1-3,5,6, 8,13,15, 16
Y	paragraph [0004] - paragraph [0007] paragraph [0016] - paragraph [0019] paragraph [0031]	4
X	US 2011/083686 A1 (YANG SZU-SUNG [US] ET AL) 14 April 2011 (2011-04-14) page 1, paragraph 3 - paragraph 4 page 2, paragraph 26 - paragraph 31 page 3, paragraph 44	1,10,16
X	WO 2009/080368 A1 (PHILIP MORRIS PROD [CH]) 2 July 2009 (2009-07-02) page 1, line 11 - line 26 page 2, line 35 - page 3, line 2 page 6, line 28 - line 34	1-3,5,6, 8,13,15, 16
X	WO 2006/097852 A1 (PHILIP MORRIS PROD [CH]) 21 September 2006 (2006-09-21) paragraph [0058] claims 1-4	1,13,16
Y	US 4 281 671 A (BYNRE STANLEY W ET AL) 4 August 1981 (1981-08-04) column 1, line 4 - line 50; figure 8	4
A	US 3 852 009 A (ROBERTS J ET AL) 3 December 1974 (1974-12-03) the whole document	1-16

INTERNATIONAL SEARCH REPORT

Information on patent family members

International application No

PCT/GB2013/051138

Patent document cited in search report	Publication date	Patent family member(s)	Publication date
WO 2009093051 A2	30-07-2009	CA 2712794 A1	30-07-2009
		CN 101938918 A	05-01-2011
		EP 2247206 A2	10-11-2010
		JP 2011509682 A	31-03-2011
		KR 20100107505 A	05-10-2010
		RU 2010134016 A	27-02-2012
		TW 200936065 A	01-09-2009
		US 2011023900 A1	03-02-2011
		WO 2009093051 A2	30-07-2009
		EP 2401929 A1	04-01-2012
CO 6680621 A2	31-05-2013		
EP 2401929 A1	04-01-2012		
EP 2587950 A1	08-05-2013		
JP 2013529920 A	25-07-2013		
KR 20130087490 A	06-08-2013		
SG 186441 A1	30-01-2013		
US 2013206151 A1	15-08-2013		
WO 2012000646 A1	05-01-2012		
US 3444863 A	20-05-1969		
		FR 1553779 A	17-01-1969
		GB 1199165 A	15-07-1970
		US 3444863 A	20-05-1969
US 2008314400 A1	25-12-2008	JP 2010527628 A	19-08-2010
		KR 20100023925 A	04-03-2010
		RU 2009149673 A	10-07-2011
		US 2008314400 A1	25-12-2008
		WO 2008146161 A2	04-12-2008
US 2011083686 A1	14-04-2011	US 2011083686 A1	14-04-2011
		WO 2011042174 A2	14-04-2011
WO 2009080368 A1	02-07-2009	AU 2008340634 A1	02-07-2009
		CN 101873810 A	27-10-2010
		CO 6220886 A2	19-11-2010
		DK 2234509 T3	08-10-2012
		EA 201070770 A1	30-12-2010
		EP 2234509 A1	06-10-2010
		ES 2390740 T3	16-11-2012
		JP 2011505851 A	03-03-2011
		KR 20100094476 A	26-08-2010
		NZ 584674 A	21-12-2012
		PL 2234509 T3	30-11-2012
		PT 2234509 E	24-08-2012
		SI 2234509 T1	31-08-2012
		US 2010006112 A1	14-01-2010
		WO 2009080368 A1	02-07-2009
WO 2006097852 A1	21-09-2006	US 2006207620 A1	21-09-2006
		WO 2006097852 A1	21-09-2006
US 4281671 A	04-08-1981	AR 218125 A1	15-05-1980
		AT 370292 B	10-03-1983
		AU 529593 B2	16-06-1983
		AU 4551479 A	25-10-1979
		BE 875736 A1	16-08-1979

INTERNATIONAL SEARCH REPORT

Information on patent family members

International application No

PCT/GB2013/051138

Patent document cited in search report	Publication date	Patent family member(s)	Publication date				
		BR 7902479 A	30-10-1979				
		CA 1113334 A1	01-12-1981				
		CH 630513 A5	30-06-1982				
		DD 143206 A5	13-08-1980				
		DE 2914892 A1	31-10-1979				
		ES 245829 U	16-01-1980				
		ES 479763 A1	16-02-1980				
		ES 484500 A1	16-04-1980				
		FR 2423169 A1	16-11-1979				
		GB 2020158 A	14-11-1979				
		GR 67711 A1	14-09-1981				
		IE 48499 B1	06-02-1985				
		IL 57051 A	31-12-1981				
		IT 1112870 B	20-01-1986				
		JP S5558084 A	30-04-1980				
		JP S6338187 B2	28-07-1988				
		NL 7903179 A	23-10-1979				
		PT 69507 A	01-05-1979				
		SE 437212 B	18-02-1985				
		SE 7903445 A	22-10-1979				
		US 4281671 A	04-08-1981				
		ZA 7901444 A	30-04-1980				
<table style="width: 100%; border-collapse: collapse;"> <tr> <td style="width: 30%;">US 3852009</td> <td style="width: 15%;">A</td> <td style="width: 45%;">03-12-1974</td> <td style="width: 10%;">NONE</td> </tr> </table>				US 3852009	A	03-12-1974	NONE
US 3852009	A	03-12-1974	NONE				