

Nov. 13, 1962

C. R. SATRUM

3,064,231

BATTERY POST CLAMP OF THE CLIP TYPE

Filed Oct. 8, 1959

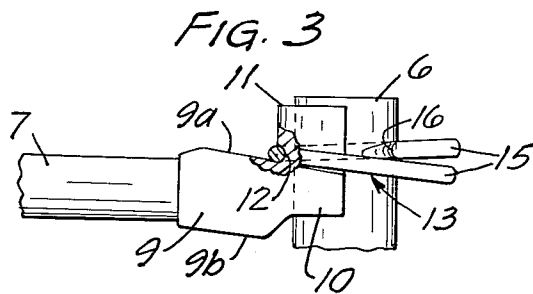
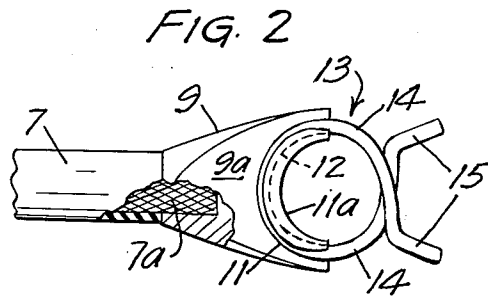
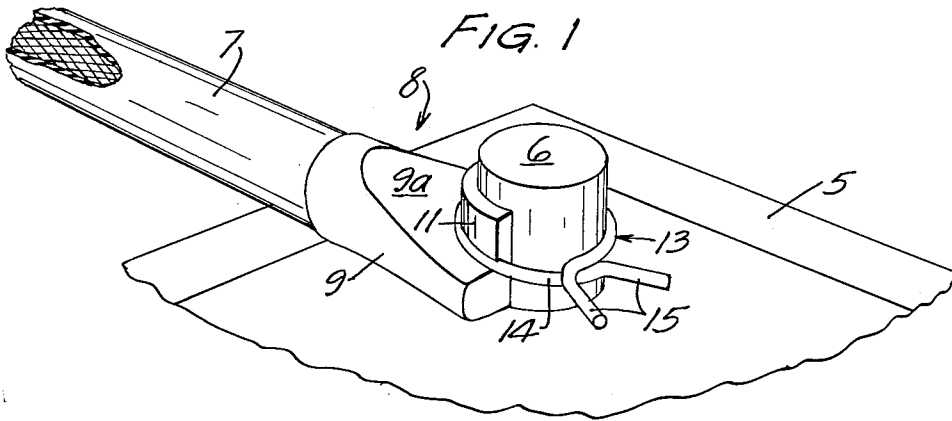

INVENTOR
BY CLARENCE R. SATRUM
Williamson, Schroeder & Palmater
ATTORNEYS

1

3,064,231

BATTERY POST CLAMP OF THE CLIP TYPE
Clarence R. Satrum, Minneapolis, Minn., assignor to Ho-
Boy Corporation, Minneapolis, Minn., a corporation
of Minnesota

Filed Oct. 8, 1959, Ser. No. 845,202

1 Claim. (Cl. 339-228)

This invention relates to cable terminal clamps or connections and in particular to a battery terminal clamp or connector for use in connecting the ends of battery cables to the terminal posts of storage batteries.

An object of my invention is a battery terminal clamp which is simple in design and inexpensive in construction, easy to operate and readily connected and disconnected to the terminal post.

Still another object is a battery terminal clamp which permits ready connection or disconnection with the terminal post of the storage battery without damaging or injuring said post or the connection between said post and said battery as frequently occurs with battery terminal connections presently available.

Still another object is a battery terminal clamp which requires no special tools and which in some instances may be installed and removed by hand without employing any tools whatsoever.

Another object is a terminal clamp functioning as a unit and requiring only a single operation or manipulation to connect or disconnect it with a terminal post, which operation does not include the undesirable tapping of the clamping member and tightening or loosening of clamping head bolts associated with conventional terminal clamps presently available.

A further object is a terminal clamp which will not work loose from the battery post when the post becomes corroded and worn.

A still further object is a terminal clamp which is adapted to firmly grip battery posts of varying cross-sectional size and which will not freeze to the post over long periods of usage.

These and other objects and advantages of my invention will more fully appear from the following description made in connection with the accompanying drawings wherein like reference characters refer to the same or similar parts, and in which:

FIG. 1 is a perspective view of the terminal clamp of my invention mounted on a battery terminal post;

FIG. 2 is a top plan view of my terminal clamp with portions thereof broken away; and

FIG. 3 is a side elevational view with portions broken away.

Reference is now made to the drawings for a more detailed description of the terminal clamp of my invention. FIG. 1 illustrates a portion of a conventional storage battery 5 having the usual terminal post 6, said post 6 being connected to a battery cable 7 by means of the battery clamp or connector 8 of my invention.

The battery clamp 8 of my invention comprises a body or head portion 9 secured to one end of the cable 7 and enclosing and engaging the conductive portion 7a FIG. 2, of the cable therewithin. The upper and lower faces 9a and 9b respectively of the head 9 are slightly inclined downwardly and forwardly and terminate in a reduced portion 10. The forward or leading end of the head 9 is provided with an upstanding arcuately shaped cylindrical segment or wall portion 11, the forward or inner face 11a of which is concavely contoured to tightly grip and engage approximately 180 degrees of the periphery of the terminal battery post 6. The outer or rearward periphery of the wall portion 11 is provided with an annular peripheral groove 12 disposed adjacent the upper face 9a of the head 9. The groove 12 is helical in na-

2

ture to correspond to the spring clip 13 and is inclined downwardly on one side approximately the same angle as the upper face 9a of the head and diagonally disposed with respect to the vertical axis of the wall 11 for a purpose hereinafter to be described.

A clamping member such as a single helical coil or spring clip 13 made of suitably tempered spring wire having good electrical conductivity and preferably having a relatively high resistance to corrosion is detachably mounted on the head 9 with the bight portion thereof being received by and seated in the peripheral groove 12 and freely slidable therein. The remaining portion of the clip 13 comprising the arcuate forward portions 14 of the clip are adapted to encircle and resiliently grip the terminal post 6 to secure the head 9 and cable 7 to the post. The ends of the clip 13 are crossed and axially bent or offset from the main portion thereof to provide a pair of forwardly extending fingers or handles 15, which are adapted to be manipulated or grasped by any suitable means such as between the fingers or by a jawed tool such as a pair of pliers to expand the coil and enlarge the bore of the clip 13 to facilitate connecting or disconnecting the clamp to the terminal post 6.

Since the conventional battery terminal post is made of a soft metal such as lead, the spring clip 13 is preferably suitably tensioned so as to strongly and resiliently grip the post and slightly depress or deform the portion of the post engaged thereby as at 16 to provide a secure attachment therewith to prevent the clamp from working loose from the post during use. Because of the resilient tensioned nature of the clip 13, it will contract as the post 6 corrodes or wears and continue to firmly grip the same. In addition, the diagonal disposition of the groove 12 with respect to the wall 11 and the post engaged thereby causes a corresponding diagonal relationship between the coil 13 and the post 6 which effects a binding relationship between the post and the clip which further enhances the locking relationship therebetween and is particularly important in those instances where the coil might not effectively depress or deform the post to a degree sufficient to form a firm positive locking action therebetween.

In use, the fingers or handles 15 of the clip 13 are pressed or squeezed towards one another to enlarge the opening provided by the clip 13 to permit the post 6 to readily pass therethrough for ready connection or disconnection with said post. In some instances however the top of the post may be beveled or worn to an extent which permits the clip 13 to be simply placed thereon and pushed downwardly thereover without manipulation of the handles 15. Because of the resilient nature of the clip 13, the release of the fingers 14 causes the coil to contract and securely engage the post 6.

From the foregoing, the advantages of my invention are readily apparent. The battery clamp is easily and inexpensively made, and extremely easy to operate. The clamp is highly efficient because it securely clamps or locks the cable to the terminal post and will not work loose as the post becomes corroded or worn or because of the continuous vibrations and shock normally encountered during use. The seating of the clip 13 in the peripheral groove 12 and the depression formed in the post by the engagement of the clip therewith provides a positive locking action preventing relative vertical or axial movement between the clip and the head and post. The groove 12 also enables the clip to be retained on the clamp without danger of losing the clip when the clamp is not in use, and permits the clamp and clip to be shipped and stored together as a unit. Because the clip is freely slidable in the groove 12 and rotatable about the wall 11, the clip may be turned through better than 180 degrees of rotation to permit the handles 15 to be positioned in the

most desirable location or angle for manipulating same. The wrap-around tensioned nature of the clip also causes the clip to wear a deeper depression in the post to effect a still more positive locking action with the post if and when the clip is caused to turn or is worked about the post when mounted thereon. In addition, the clamp of my invention eliminates the possibility of damage or injury to the post due to the tapping, pounding and prying normally required to connect and disconnect terminal clamps presently available and also avoids the inconvenient manipulation of mechanical fastening means such as nuts and bolts which are also usually required with presently available battery clamps.

It will, of course, be understood that various changes may be made in the form, details, arrangement and proportions of the various parts without departing from the scope of my invention.

What I claim is:

A battery terminal clamp comprising a body member adapted for connection with a cable, said body member having a concave portion for receiving an engaging not more than half of the periphery of a battery terminal post and also having an upstanding arcuate clip engaging

5 wall portion forming a part of said concave portion, and a helically coiled annular spring clip having disconnected end portions, said clip engaging said arcuate wall portion and adapted to enclose said concave portion and said post and positively engage said post to hold the body member thereagainst, said clip defining with said concave portion a post receiving opening normally smaller than said post whereby the clip is expanded and tensioned by the seating of the post in said opening, said clip being free to expand and contract independently of and relative to said body member and its arcuate wall portion and being freely disconnectable therefrom.

References Cited in the file of this patent

UNITED STATES PATENTS

1,808,368	Montambault	June 2, 1931
1,977,402	Peglar	Oct. 16, 1934
2,128,888	Pierpoint	Aug. 30, 1938
2,602,105	Welch et al.	July 1, 1952
2,663,815	Mucher	Dec. 22, 1953

FOREIGN PATENTS

504,922	Canada	Aug. 10, 1954
---------	--------	---------------