



- (51) International Patent Classification:
B29D 30/08 (2006.01) *B29D 30/16* (2006.01)
- (21) International Application Number:
PCT/US2015/061048
- (22) International Filing Date:
17 November 2015 (17.11.2015)
- (25) Filing Language: English
- (26) Publication Language: English
- (30) Priority Data:
62/095,463 22 December 2014 (22.12.2014) US
- (71) Applicant: **BRIDGESTONE AMERICAS TIRE OPERATIONS, LLC** [US/US]; 535 Marriott Drive, Nashville, Tennessee 37214 (US).
- (72) Inventors: **STUCKEY, Jon I.**; 763 September Drive, Uniontown, Ohio 44685 (US). **BARNED, Robert G.**; 224 Avondale Drive, Akron, Ohio 44313 (US). **KIRBY, James M.**; 242 Clinton Drive, Akron, Ohio 44301 (US).
- (74) Agents: **JUPINA, Matthew W.** et al.; 10 East Firestone Blvd., Akron, Ohio 44317 (US).

- (81) Designated States (unless otherwise indicated, for every kind of national protection available): AE, AG, AL, AM, AO, AT, AU, AZ, BA, BB, BG, BH, BN, BR, BW, BY, BZ, CA, CH, CL, CN, CO, CR, CU, CZ, DE, DK, DM, DO, DZ, EC, EE, EG, ES, FI, GB, GD, GE, GH, GM, GT, HN, HR, HU, ID, IL, IN, IR, IS, JP, KE, KG, KN, KP, KR, KZ, LA, LC, LK, LR, LS, LU, LY, MA, MD, ME, MG, MK, MN, MW, MX, MY, MZ, NA, NG, NI, NO, NZ, OM, PA, PE, PG, PH, PL, PT, QA, RO, RS, RU, RW, SA, SC, SD, SE, SG, SK, SL, SM, ST, SV, SY, TH, TJ, TM, TN, TR, TT, TZ, UA, UG, US, UZ, VC, VN, ZA, ZM, ZW.
- (84) Designated States (unless otherwise indicated, for every kind of regional protection available): ARIPO (BW, GH, GM, KE, LR, LS, MW, MZ, NA, RW, SD, SL, ST, SZ, TZ, UG, ZM, ZW), Eurasian (AM, AZ, BY, KG, KZ, RU, TJ, TM), European (AL, AT, BE, BG, CH, CY, CZ, DE, DK, EE, ES, FI, FR, GB, GR, HR, HU, IE, IS, IT, LT, LU, LV, MC, MK, MT, NL, NO, PL, PT, RO, RS, SE, SI, SK, SM, TR), OAPI (BF, BJ, CF, CG, CI, CM, GA, GN, GQ, GW, KM, ML, MR, NE, SN, TD, TG).

Published:
— with international search report (Art. 21(3))

(54) Title: METHOD OF APPLYING A POST CURE LAMINATE TO A TIRE

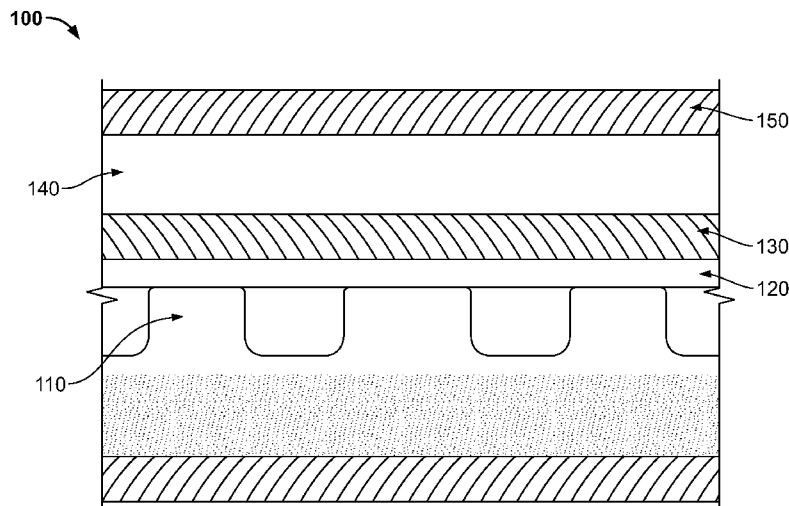

FIG. 1

(57) Abstract: A method of applying a laminate to a tire includes pre-treating a portion of the tire and placing the laminate on at least the pre-treated portion of the tire. The method further includes placing an electrical heating element on top of the laminate and placing a pressure element over the electrical heating element and the laminate. The method also includes applying heat and pressure to the laminate using the electrical heating element and the pressure element to permanently adhere the laminate to the tire.



METHOD OF APPLYING A POST CURE LAMINATE TO A TIRE

FIELD OF INVENTION

[0001] The present disclosure relates to a tire having a laminate disposed thereon and to methods of its preparation. More particularly, the present disclosure relates to various methods for applying an uncured laminate to one or more portions of a cured tire.

BACKGROUND

[0002] Applying compound laminates to tires can alter the performance characteristics of the tire. Existing methods for applying an uncured compound laminate to a tire requires expensive and specialized equipment. Existing methods may be improved by providing a simplified method that uses inexpensive equipment to reduce the cost.

SUMMARY

[0003] In one embodiment, a method of applying a laminate to a cured tire includes providing a cured tire and pre-treating a portion of a tread of a tire. The method further includes providing a laminate, placing the laminate on the pre-treated portion of the tread of the tire, and placing an electrical heating element on a top of the laminate. The method also includes placing a toroidal air bag over the electrical heating element and the laminate and pressurizing the toroidal air bag. The method further includes applying heat sufficient to cure the laminate with the electrical heating element, thereby permanently affixing the laminate to the tire. The laminate alters performance characteristics of the tire when affixed to the tire.

[0004] In another embodiment, a method of applying a laminate to a tire includes placing a laminate on a portion of a tire, placing an electrical heating element on top of the laminate, and placing a pneumatic pressure element over the electrical heating element and the laminate. The method also includes applying heat to the laminate using the electrical heating element and applying pressure to the laminate using the pneumatic pressure element, to permanently adhere the laminate to the tire.

[0005] In yet another embodiment, a method of applying a laminate to a tire includes pre-treating a portion of the tire and placing the laminate on at least the pre-treated portion of the tire. The method further includes placing an electrical heating element on top of the laminate and placing a pressure element over the electrical heating element and the laminate. The method also includes applying heat and pressure to the laminate using the electrical heating element and the pressure element to permanently adhere the laminate to the tire.

BRIEF DESCRIPTION OF THE DRAWINGS

[0006] In the accompanying drawings, structures are illustrated that, together with the detailed description provided below, describe exemplary embodiments of the claimed invention. Like elements are identified with the same reference numerals. It should be understood that elements shown as a single component may be replaced with multiple components, and elements shown as multiple components may be replaced with a single component. The drawings are not to scale and the proportion of certain elements may be exaggerated for the purpose of illustration.

[0007] **Figure 1** is a side view of one embodiment of an assembly for applying a laminate to a tire.

[0008] **Figure 2** is a side view of the assembly of **Figure 1**.

[0009] **Figure 3** is a front cross section view of the assembly of **Figure 1**.

[0010] **Figure 4** is a flow chart of one embodiment of a method of applying a laminate to a tire.

[0011] **Figure 5** is a side view of an alternative pressure element that may be used in the method of **Figure 1**.

[0012] **Figure 6** is a front section view of the alternative pressure element of **Figure 5**.

DETAILED DESCRIPTION

[0013] The following includes definitions of selected terms employed herein. The definitions include various examples or forms of components that fall within the scope of a term and that may be used for implementation. The examples are not intended to be limiting. Both singular and plural forms of terms may be within the definitions.

[0014] “Axial” and “axially” refer to a direction that is parallel to the axis of rotation of a tire.

[0015] “Equatorial plane” refers to the plane that is perpendicular to the tire’s axis of rotation and passes through the center of the tire’s tread.

[0016] “Radial” and “radially” refer to a direction perpendicular to the axis of rotation of a tire.

[0017] “Sidewall” refers to that portion of the tire between the tread and the bead.

[0018] “Tread” as used herein, refers to that portion of the tire that comes into contact with the road or ground under normal inflation and load.

[0019] Directions are stated herein with reference to the axis of rotation of the tire. The terms “upward” and “upwardly” refer to a general direction towards the tread of the tire, whereas “downward” and “downwardly” refer to the general direction towards the axis of rotation of the tire. Thus, when relative directional terms such as “upper” and “lower” or “top” and “bottom” are used in connection with an element, the “upper” or “top” element is spaced closer to the tread than the “lower” or “bottom” element. Additionally, when relative directional terms such as “above” or “below” are used in connection with an element, an element that is “above” another element is closer to the tread than the other element.

[0020] The terms “inward” and “inwardly” refer to a general direction towards the equatorial plane of the tire, whereas “outward” and “outwardly” refer to a general direction away from the equatorial plane of the tire and towards the sidewall of the tire. Thus, when relative directional terms such as “inner” and “outer” are used in connection with an element, the “inner” element is spaced closer to the equatorial plane of the tire than the “outer” element.

[0021] **Figure 1** depicts one embodiment of an assembly for applying a laminate to a tire **100**. Initially, the components of the assembly will be described individually to provide context for a description of the method.

[0022] The tire **100** is a cured tire having a circumferential tread **110**. The tire **100** can be any type of tire, including but not limited to a tire for an automobile, a truck a motorcycle, an airplane, agriculture equipment, or mining equipment. Although not shown in **Figure 1**, tire **100** also includes shoulder regions connecting the tread to sidewalls of the tire, and bead regions located at a radially lower end of the sidewalls.

[0023] A separate layer of a laminate compound **120** is placed on a surface of the tire **100**. The embodiment of **Figure 1** depicts the laminate compound **120** being applied to a tread **110** of the tire **100**. In alternative embodiments (not shown), the laminate compound **120** may be applied to the shoulder regions, sidewalls, bead regions, or a combination thereof.

[0024] The laminate compound **120** can be made from an elastomeric or polymeric material, including, without limitation, natural rubber, synthetic polyisoprene, polybutadiene, styrene butadiene, thermoplastic, polyurethane, and combinations thereof. and the laminate compound **120** has the effect of changing the performance properties of tire **100** when affixed to a tread surface of tire **100**. The material properties of the laminate may be varied according to the vehicle type, and the expected use of the tire. In one embodiment, the laminate has a thickness of less than 1.5 millimeters. In another embodiment, the laminate has a thickness of 1.0 to 1.5 millimeters. However, it should be understood that thicker laminates may be employed. The thickness of the laminate may be exaggerated in the drawings for illustrative purposes. The laminate compound **120** may further be partially crosslinked by heat or radiation prior to being placed on top of the

surface of the tire. The cross linking provides dimensional stability during processing.

[0025] Further, laminate compound **120** may be precut to correspond to surface features of the tire, such as grooves or sipes in the tread, lettering in the sidewalls, or protruding ribs on the sidewalls. Pre-cutting the laminate reduces bridging of pattern feature of the original tire **100**.

[0026] A heating element **130** is placed above the laminate compound **120**. The heating element **130** can be a high temperature heating pad, for example. The heating element **130** should provide heat at a temperature suitable for conventional cure systems, which generally fall within the range of 130–170° C. In alternative embodiments, the temperature may be as high as 200° C or higher. Heating element **130** may further take the form of a custom geometry flexible heater, suitable for a particular application. For example heating element **130** can be manufactured to match the geometry of tire **100**.

[0027] Heating element **130** may provide heat by convection, conduction, radiation, or any combination thereof. For example, heating element **130** may include an electrical heating system that provides heat through radiation and conduction.

[0028] A pressure element **140** is disposed above the heating element **130**. Pressure element **140** can be, for example, a pneumatic pressure element such as an air bag. The pressure element provides sufficient pressure to hold the heating element **130** and laminate compound **120** in place. A minimum pressure is needed for contact and to keep volatile ingredients in solution when the compound

temperature is raised. In one embodiment, the pressure element provides between 50–300 PSI (300–2000 kPa) of pressure. In one particular embodiment, the pressure element provide 80 PSI (600 kPa) of pressure. In alternative embodiments, the pressure element may provide more the 300 PSI of pressure.

[0029] Pressure element **140** may take any geometric shape sufficient for a particular application. For example, the pressure element may have a toroid or a flat rectangular shape.

[0030] A retaining element **150** is located above pressure element **140**, to hold pressure element in place during the method of the present embodiment. In one embodiment, the retaining element is a series of elastic bands. In alternative embodiments, the retaining element includes one or more clamps, plates, inelastic bands, or other retaining elements to oppose the force from the pressure element.

[0031] In an alternative embodiments (not shown), the system may be employed to apply a replacement tread to a tire carcass, instead of applying a laminate compound to a tire tread. In such an embodiment, a new green tread will be applied to a tread surface of a cured tire, and then affixed using the same methods described above. Alternatively, the new tread may be partially or fully cured. Such a procedure may be useful, for example, if part or all of the cured tire's original tread has been worn down.

[0032] **Figures 2** and **3** depict a side and a front view, respectively of the assembly of **Figure 1**. The assembly will be described with reference to both **Figures 2** and **3**. As can be seen from this view, the pressure element **140** has multiple heating elements **130** disposed on an inner circumference thereof.

Pressure element **140** in this embodiment takes the form of a pleated toroidal air bag. The retaining element **150** takes the form of an outer ring, surrounding an outer surface of the pressure element **140**. In alternative embodiments (not shown), there may be only one heating element located on an inner circumference of the assembly, or different arrangements of multiple heating elements.

[0033] **Figure 4** is a flowchart depicting a method **200** of applying a laminate to a tire. The method **200** may be performed at a tire manufacturing facility. Alternatively, the method **200** may be performed at a tire maintenance, retreading, or repair facility, or at a retail establishment.

[0034] Initially, a tire is provided (step **210**). In one embodiment, the tire is a new tire. In an alternative embodiment, the tire is a used tire that has been partially or fully worn.

[0035] The surface of the tire undergoes a pre-treatment process for receiving a laminate (step **220**). The pre-treatment can include one or more of: cleaning, buffing, adding a cement layer, oxidizing (e.g. plasma treatment, oxidizing chemicals treatment (e.g. halohydantoin, etc.)), or applying a chemical treatment to break sulfur cross links. The pre-treatment will be performed on any surface of the tire on which laminate will be affixed. These surfaces include one or more of the tread, sidewalls, shoulders, or bead regions. In an alternative embodiment, the pre-treatment process may be shortened or omitted entirely. For example, it may not be necessary to clean the surface of a new tire.

[0036] After the tire **100** has been pre-treated, a laminate compound is placed over the pre-treated area in step **230**. After placing the laminate compound on the

tire **100**, the laminate may be pressed onto the cured tire with one or more rollers. Such a process may be referred to as “stitching” and may expel air or other gasses that become trapped between the laminate and the cured tire. A heating element **130** and a pressure element **140** are then placed on top of the laminate in steps **240** and **250**, respectively.

[0037] Once the elements are arranged as desired, the pressure element **140** is pressurized and heating element **130** is engaged to generate heat in step **260**. The pressure and heat work to cure the laminate compound **120** and permanently affix the laminate compound **120** to tire **100**.

[0038] An alternative pressure element **400** is shown in **Figure 5**. In this embodiment, pressure element **400** includes two air bags **410** and **420**. Each air bag will extend laterally across an entire tread width, but will only extend circumferentially around half of the tire. The air bags **410** and **420** overlap at two interfaces **430** and **440**. In alternative embodiments (not shown), the air bags can cover less than an entire tread width. In still other alternative embodiments, three or more pressurizing elements may be used.

[0039] **Figure 6** shows a detail view of the pressure element **400** of **Figure 5**. As can be seen from this view, a gap **G** may form at an interface **430** between the air bags **410**, **420**. Such a gap may form if the air bags **410**, **420** do not have corresponding surfaces, or if the air bags **410**, **420** are not filled to a sufficient pressure. The gap may be reduced or eliminated entirely by employing air bags having corresponding ends, and by sufficiently pressurizing the air bags.

[0040] To the extent that the term “includes” or “including” is used in the specification or the claims, it is intended to be inclusive in a manner similar to the term “comprising” as that term is interpreted when employed as a transitional word in a claim. Furthermore, to the extent that the term “or” is employed (e.g., A or B) it is intended to mean “A or B or both.” When the applicants intend to indicate “only A or B but not both” then the term “only A or B but not both” will be employed. Thus, use of the term “or” herein is the inclusive, and not the exclusive use. See, Bryan A. Garner, *A Dictionary of Modern Legal Usage* 624 (2d. Ed. 1995). Also, to the extent that the terms “in” or “into” are used in the specification or the claims, it is intended to additionally mean “on” or “onto.” Furthermore, to the extent the term “connect” is used in the specification or claims, it is intended to mean not only “directly connected to,” but also “indirectly connected to” such as connected through another component or components.

[0041] While the present disclosure has been illustrated by the description of embodiments thereof, and while the embodiments have been described in considerable detail, it is not the intention of the applicants to restrict or in any way limit the scope of the appended claims to such detail. Additional advantages and modifications will readily appear to those skilled in the art. Therefore, the disclosure, in its broader aspects, is not limited to the specific details, the representative apparatus and method, and illustrative examples shown and described. Accordingly, departures may be made from such details without departing from the spirit or scope of the applicant’s general inventive concept.

CLAIMS

What is claimed is:

1. A method of applying a laminate to a cured tire, comprising:
 - providing a cured tire;
 - pre-treating a portion of a tread of a tire;
 - providing a laminate;
 - placing the laminate on the pre-treated portion of the tread of the tire;
 - placing an electrical heating element on a top of the laminate;
 - placing a toroidal air bag over the electrical heating element and the laminate;
 - pressurizing the toroidal air bag;
 - applying heat sufficient to cure the laminate with the electrical heating element, thereby permanently affixing the laminate to the tire,
 - wherein the laminate alters performance characteristics of the tire when affixed to the tire.
2. The method of claim 1, wherein the pre-treating includes at least one of: cleaning, buffing, adding a cement layer, surface treatment by oxidizing methods, and chemical treatment.
3. The method of claim 1, wherein the laminate is crosslinked by applying heat or radiation to the laminate.

4. A method of applying a laminate to a tire, comprising:
 - placing a laminate on a portion of a tire;
 - placing an electrical heating element on top of the laminate;
 - placing a pneumatic pressure element over the electrical heating element and the laminate;
 - applying heat to the laminate using the electrical heating element;and
 - applying pressure to the laminate using the pneumatic pressure element, to permanently adhere the laminate to the tire.
5. The method of claim 4, wherein the pneumatic pressure element is an air bag.
6. The method of claim 5, wherein the air bag is a toroidal air bag.
7. The method of claim 4, wherein the pneumatic pressure element provides a pressure of 80 pounds per square inch.
8. The method of claim 4, wherein the laminate does not cover the entire tire.
9. The method of claim 8, wherein the heat is applied only to the portion of the tire where the laminate is located.
10. The method of claim 4, wherein the laminate is only applied to a tread portion of the tire.

11. A method of applying a laminate to a tire, comprising:
 - pre-treating a portion of the tire;
 - placing the laminate on at least the pre-treated portion of the tire;
 - placing an electrical heating element on top of the laminate;
 - placing a pressure element over the electrical heating element and the laminate; and
 - applying heat and pressure to the laminate using the electrical heating element and the pressure element to permanently adhere the laminate to the tire.
12. The method of claim 11, wherein the pre-treating includes one or more of: cleaning, buffing, adding a cement layer, surface treatment by oxidizing methods, and chemical treatment.
13. The method of claim 11, wherein the pre-treated portion of the tire is located on a sidewall of the tire.
14. The method of claim 11, wherein the pre-treated portion of the tire is located on a shoulder of the tire.
15. The method of claim 11, wherein the pressure element provides a pressure of 80 pounds per square inch.
16. The method of claim 11, wherein the tire is pre-treated at a plurality of locations, and a plurality of laminates are applied to the plurality of pre-treated locations.

17. The method of claim 16, further comprising pressing the laminate onto the pre-treated portion of the tire with one or more rollers.

18. The method of claim 11, wherein the laminate is only applied to a portion of a tread of the tire.

19. The method of claim 11, wherein the electrical heating element is placed only on the laminate, and does not heat portions of the tire that are not pre-treated.

20. The method of claim 11, wherein crosslinking is performed by heat or radiation.

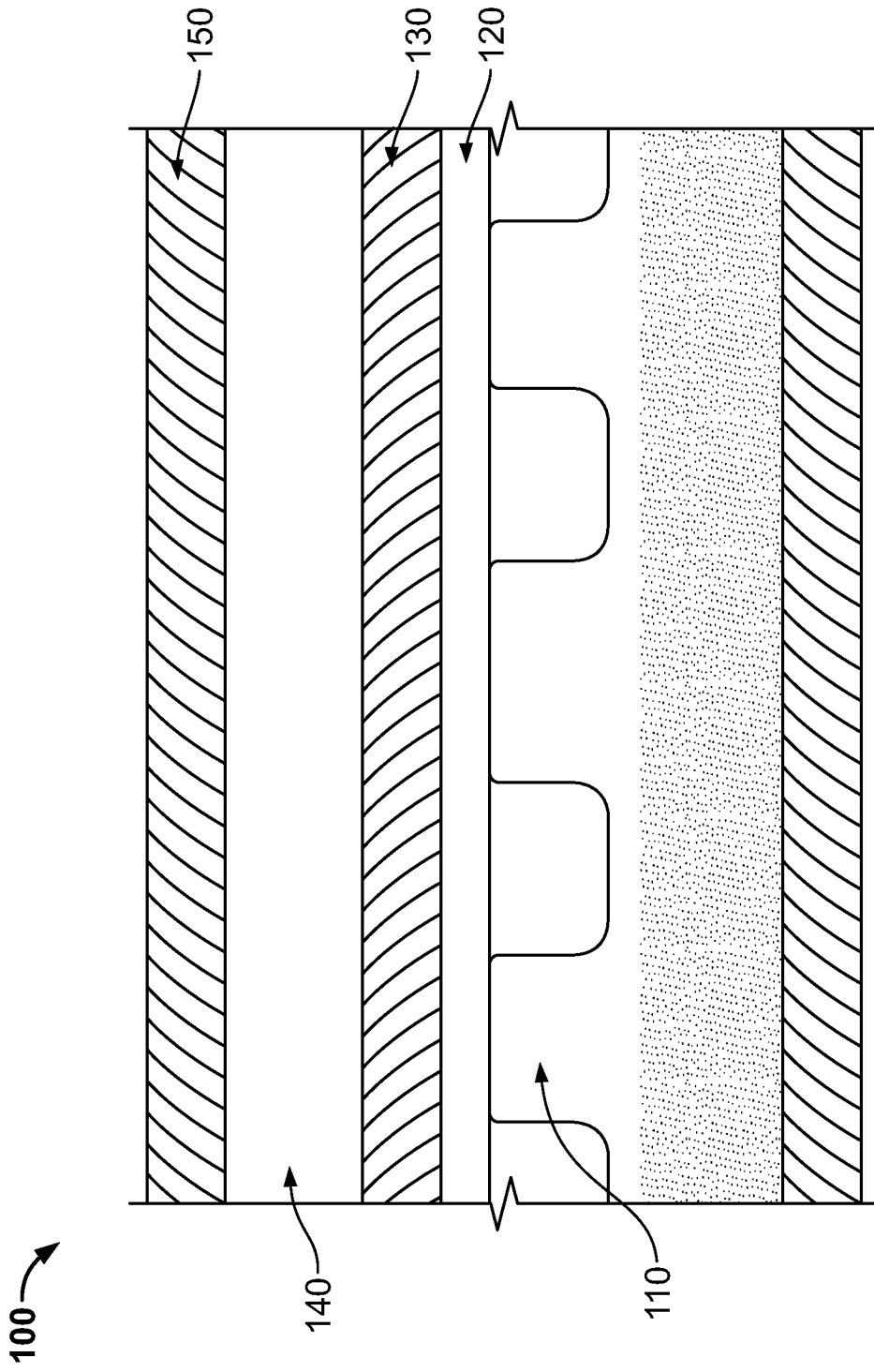

FIG. 1

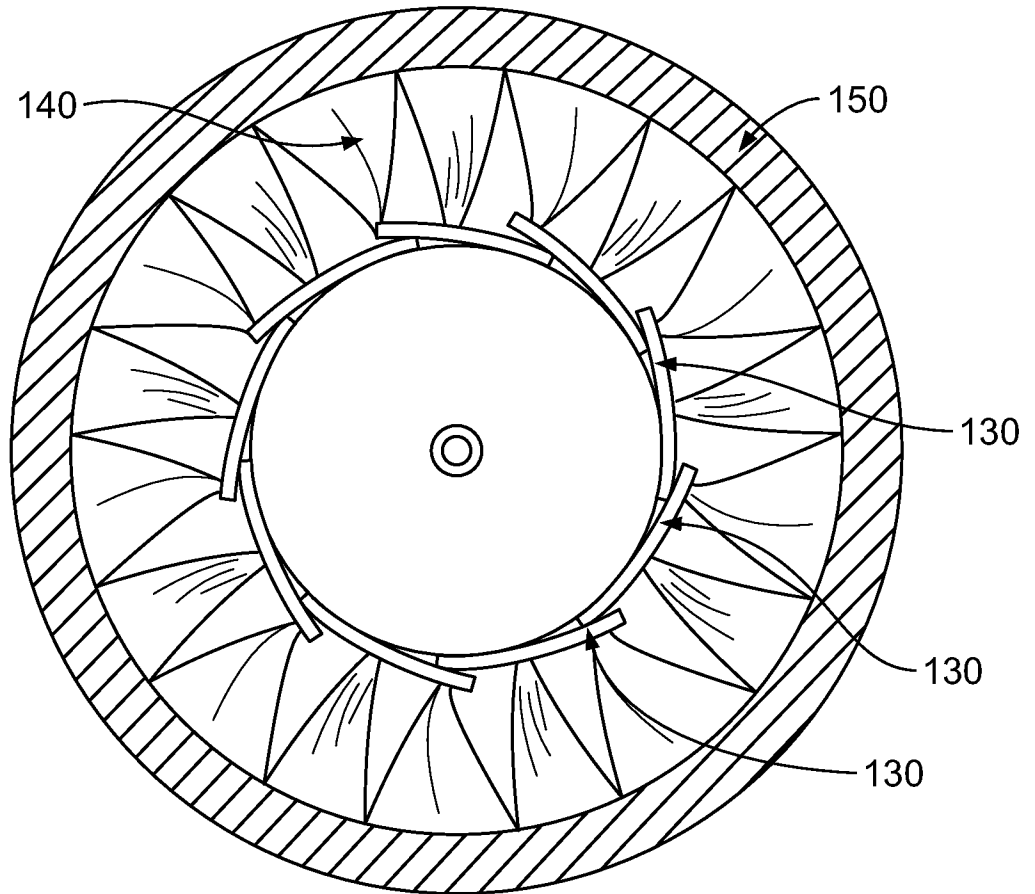

FIG. 2

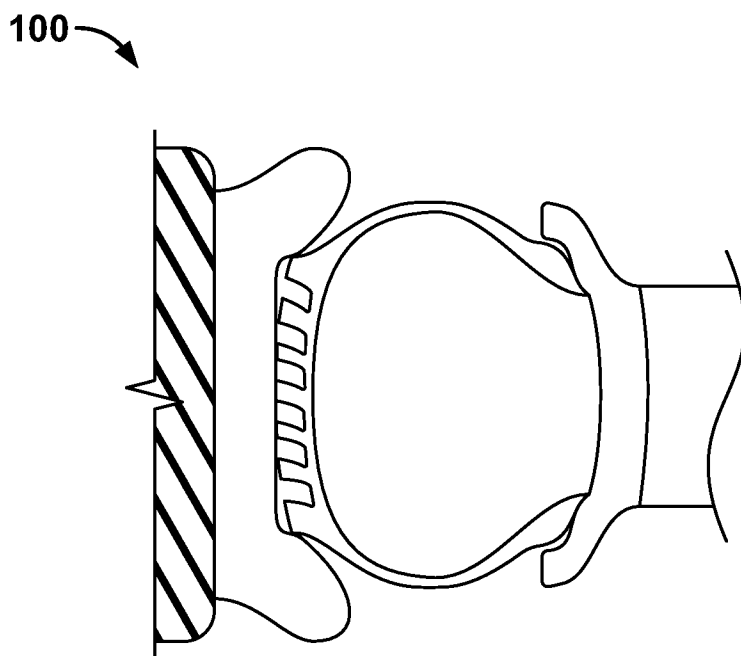

FIG. 3

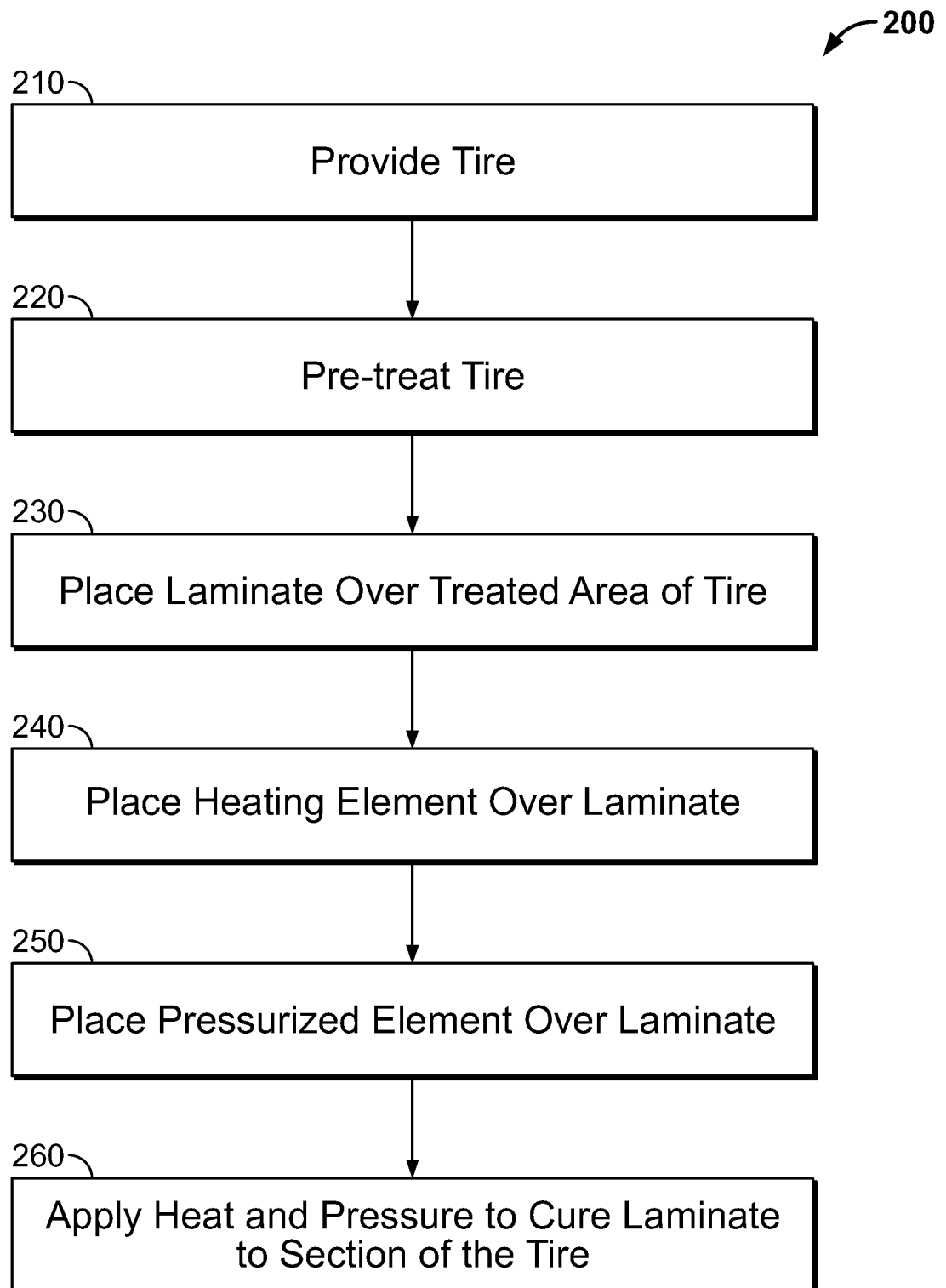

FIG. 4

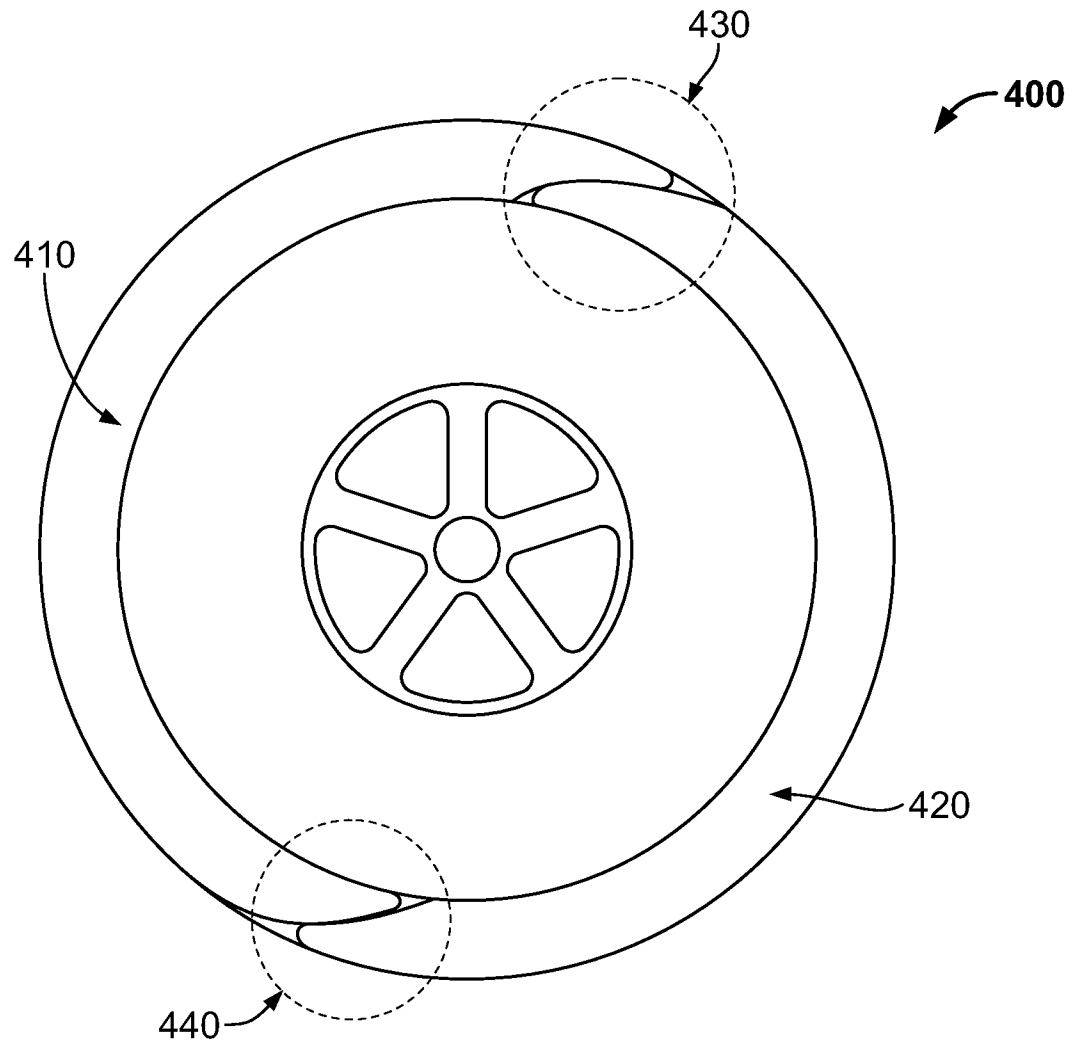

FIG. 5

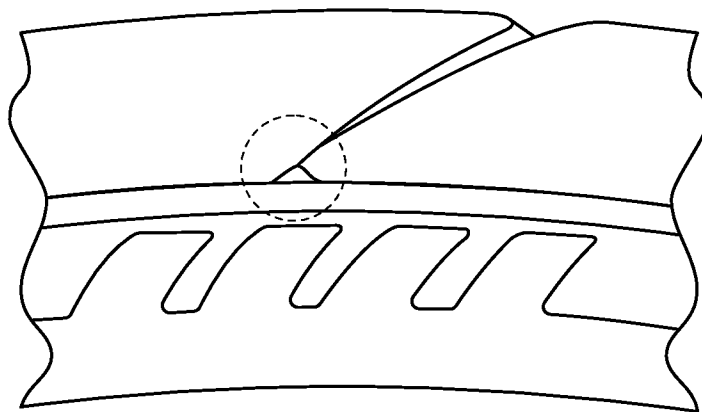

FIG. 6

INTERNATIONAL SEARCH REPORT

International application No.
PCT/US2015/061048**A. CLASSIFICATION OF SUBJECT MATTER****B29D 30/08(2006.01)i, B29D 30/16(2006.01)i**

According to International Patent Classification (IPC) or to both national classification and IPC

B. FIELDS SEARCHED

Minimum documentation searched (classification system followed by classification symbols)

B29D 30/08; B60C 11/00; B29H 17/08; B29D 30/00; B29C 35/00; B60C 5/00; B29C 33/02; B29L 30/00; B60C 13/00; B29D 30/16

Documentation searched other than minimum documentation to the extent that such documents are included in the fields searched

Korean utility models and applications for utility models

Japanese utility models and applications for utility models

Electronic data base consulted during the international search (name of data base and, where practicable, search terms used)

eKOMPASS(KIPO internal) & Keywords: tire, laminate, cure, heat, pressure, performance characteristics

C. DOCUMENTS CONSIDERED TO BE RELEVANT

| Category* | Citation of document, with indication, where appropriate, of the relevant passages | Relevant to claim No. |
|-----------|--|-----------------------|
| A | KR 10-0297446 B1 (HANKUK TIRE WORLDWIDE CO., LTD.) 5 November 2001 see abstract; claim 1; and figures 1, 5. | 1-20 |
| A | US 4089360 A (BOHM, G. G. A.) 16 May 1978 See abstract; claim 1; and figure 4. | 1-20 |
| A | US 2002-0033557 A1 (HASHIMURA, Y. et al.) 21 March 2002 See abstract; and claim 1. | 1-20 |
| A | JP 2009-149034 A (YOKOHAMA RUBBER CO., LTD.) 9 July 2009 See abstract; and claim 1. | 1-20 |
| A | JP 2013-010295 A (BRIDGESTONE CORP.) 17 January 2013 See abstract; and claim 1. | 1-20 |

 Further documents are listed in the continuation of Box C. See patent family annex.

* Special categories of cited documents:

"A" document defining the general state of the art which is not considered to be of particular relevance

"E" earlier application or patent but published on or after the international filing date

"L" document which may throw doubts on priority claim(s) or which is cited to establish the publication date of another citation or other special reason (as specified)

"O" document referring to an oral disclosure, use, exhibition or other means

"P" document published prior to the international filing date but later than the priority date claimed

"T" later document published after the international filing date or priority date and not in conflict with the application but cited to understand the principle or theory underlying the invention

"X" document of particular relevance; the claimed invention cannot be considered novel or cannot be considered to involve an inventive step when the document is taken alone

"Y" document of particular relevance; the claimed invention cannot be considered to involve an inventive step when the document is combined with one or more other such documents, such combination being obvious to a person skilled in the art

"&" document member of the same patent family

Date of the actual completion of the international search

22 February 2016 (22.02.2016)

Date of mailing of the international search report

29 February 2016 (29.02.2016)

Name and mailing address of the ISA/KR

International Application Division

Korean Intellectual Property Office

189 Cheongsa-ro, Seo-gu, Daejeon, 35208, Republic of Korea

Facsimile No. +82-42-472-7140

Authorized officer

CHANG, Bong Ho

Telephone No. +82-42-481-3353

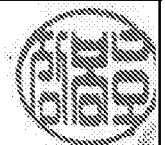

INTERNATIONAL SEARCH REPORT

Information on patent family members

International application No.

PCT/US2015/061048

| Patent document cited in search report | Publication date | Patent family member(s) | Publication date |
|--|------------------|---|--|
| KR 10-0297446 B1 | 05/11/2001 | None | |
| US 4089360 A | 16/05/1978 | JP 1223345 C JP 52-039780 A JP 53-057284 A JP 58-055905 B2 JP 59-041858 B2 JP 5941858 B2 US 04140167 A US 04171237 A | 15/08/1984 28/03/1977 24/05/1978 12/12/1983 11/10/1984 11/10/1984 20/02/1979 16/10/1979 |
| US 2002-0033557 A1 | 21/03/2002 | DE 10134865 A1 JP 04496614 B2 JP 2002-028987 A US 6663735 B2 | 14/03/2002 07/07/2010 29/01/2002 16/12/2003 |
| JP 2009-149034 A | 09/07/2009 | CN 101903149 A CN 101903149 B EP 2221159 A1 EP 2221159 A4 EP 2221159 B1 JP 04297290 B2 KR 10-1515669 B1 KR 10-2010-0106979 A US 2010-0327495 A1 US 8158050 B2 WO 2009-081656 A1 | 01/12/2010 23/10/2013 25/08/2010 23/05/2012 05/03/2014 15/07/2009 27/04/2015 04/10/2010 30/12/2010 17/04/2012 02/07/2009 |
| JP 2013-010295 A | 17/01/2013 | None | |