

1,434,065.

Patented Oct. 31, 1922.
2 SHEETS—SHEET 1.

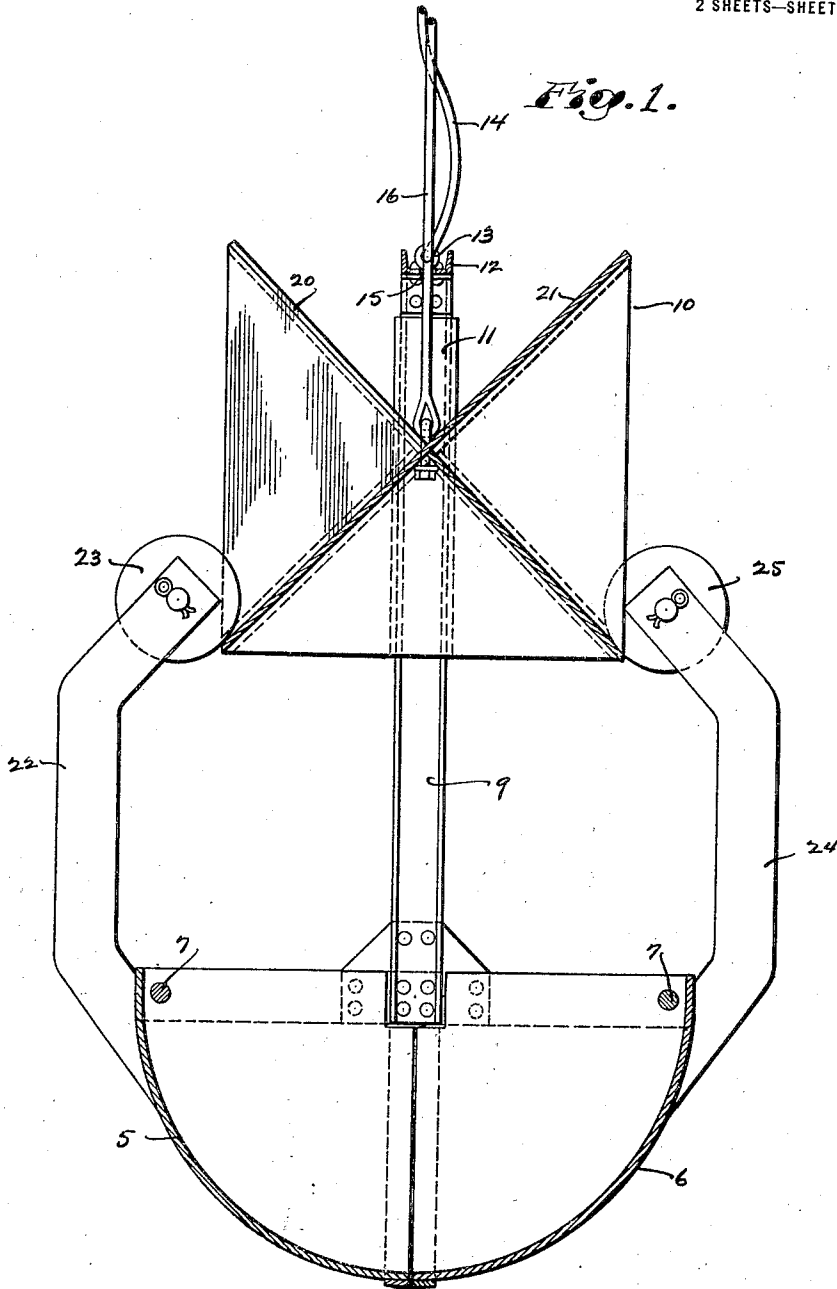

Inventor:
Ephraim Prefontaine
by J. W. Ellis
Atty.

E. PREFONTAINE.
GRAB BUCKET.
APPLICATION FILED JAN. 14, 1921.

1,434,065.

Patented Oct. 31, 1922.

2 SHEETS—SHEET 2.

Fig. 3.

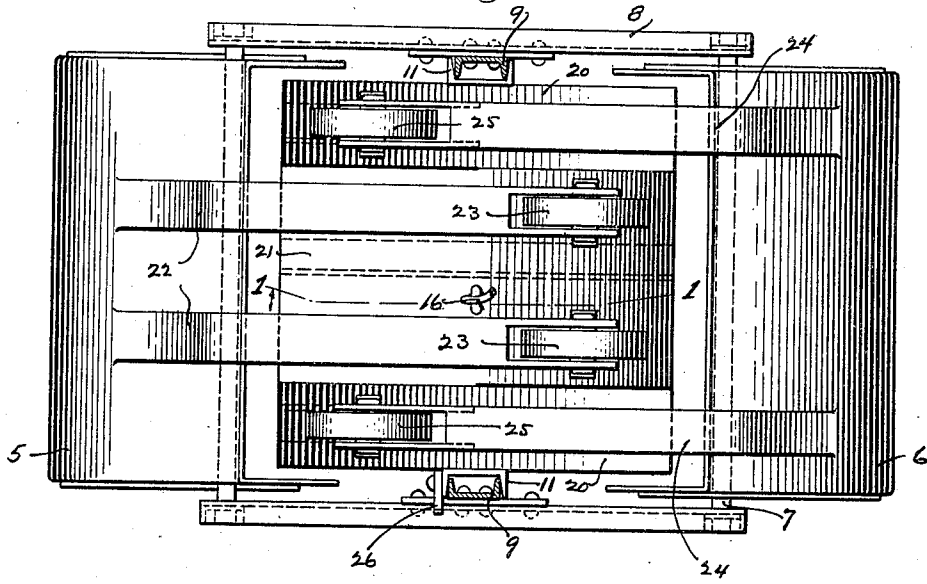
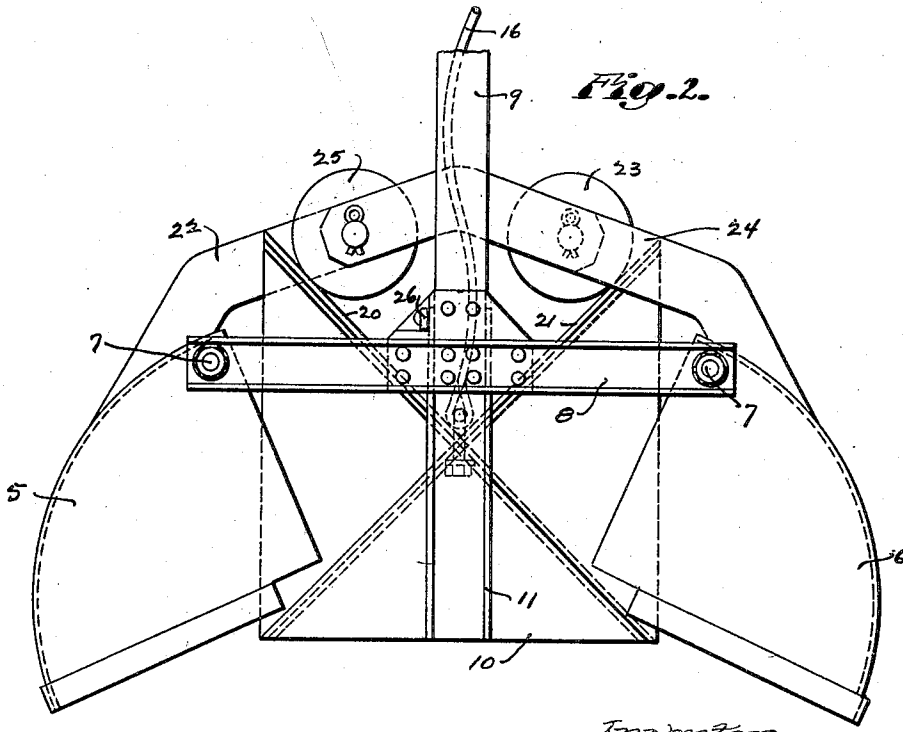

Fig. 2.



Inventor
Ephrem Prefontaine
by J. W. Ellis
Att'y

UNITED STATES PATENT OFFICE.

EPHREM PREFONTAINE, OF BUFFALO, NEW YORK.

GRAB BUCKET.

Application filed January 14, 1921. Serial No. 437,133.

To all whom it may concern:

Be it known that I, EPHREM PREFONTAINE, a citizen of the United States of America, and a resident of the city of Buffalo, county of Erie, and State of New York, have invented certain new and useful Improvements in Grab Buckets, of which the following is a full, clear, and exact description.

My invention relates generally to grab buckets and more particularly to that type of bucket which is provided with a holding rope and a closing rope, and is used for handling ores and similar substances.

The principal object of my invention has been to provide a bucket of this type having a simplified construction in which all sheaves, idlers, and rope reaving shall be eliminated.

Another object has been to provide a bucket of very few parts; and one which, because of its few parts, shall not easily get out of order.

The above advantages have been accomplished by the device shown in the accompanying drawings, of which:

Fig. 1 is a side, sectional elevation, taken on line 1—1 of Fig. 3, and shows my bucket in its closed position.

Fig. 2 is a side elevation of my bucket in its full open position.

Fig. 3 is a plan view of the bucket, partly in section, when the parts occupy the positions shown in Fig. 2.

My bucket comprises two bucket segments 5 and 6, each pivotally mounted on bearing rods 7. These rods are supported by girders 8, one arranged at each side of the bucket.

Rising vertically from each of the girders 8 and secured midway the length of each, is a guide 9. A closing member 10 is arranged between the guides 9 and is provided at each side with guide ways 11 which are in sliding engagement with the guides 9. The guides 9 are tied together at their upper ends by means of a yoke 12. This yoke carries an eye 13 to which a holding rope 14 is attached, whereby the bucket will be raised or lowered. The yoke 12 is provided with an opening 15 through which a closing rope 16 is passed. The lower end of the closing rope is attached to the closing member 10, whereby this member may be vertically reciprocated between the guides 9.

The closing member 10 is provided with oppositely arranged, inclined surfaces 20

and 21. There are two surfaces 20, one arranged at each side of the surface 21. The surfaces 20 are inclined in the same direction and at the same angle. The surface 21 is inclined at preferably the same angle as the surfaces 20 but in an opposite direction. The closing member is preferably of such a size that it will move down in between the bearing rods 7, and is preferably of a webbed, reinforced construction so that it will be light as well as strong. A stop 26 is carried by each of the guide ways 11, and these stops are engageable with the girders 8 when the closing member has reached its maximum downward movement.

Carried by the bucket segment 5 are two closing arms 22 which are secured at points outside the bearing pin 7. These arms extend upwardly and each is provided at its upper end with a roller 23. Likewise, the bucket segment 6 is provided with two closing arms 24, each of which is provided at its upper end with a roller 25. The rollers 23 are engageable with the inclined surface 21 of the closing member 10, and each of the rollers 25 is engageable with one of the inclined surfaces 20 of the closing member.

When the closing member 10 is lowered from the position shown in Fig. 1, and while the bucket is being held by the holding rope 14, it will be seen that the rollers 23 and 25 will move inwardly toward and past the center line of the bucket, thereby opening the bucket segments 5 and 6. When the bucket has been opened to its maximum, the parts will occupy the positions shown in Fig. 2. When the bucket is lowered onto the material being handled and the holding rope slackened, the bucket segments will be closed by the action of the inclined surfaces 20 and 21 and the rollers 23 and 25 as the closing member 10 is elevated by the closing rope 16.

Obviously, some modifications of the details herein shown and described may be made without departing from the spirit of my invention or the scope of the appended claims; and I do not, therefore, wish to be limited to the exact embodiment herein shown and described, the form described being merely a preferred embodiment thereof.

Having thus described my invention what I claim is:

1. A grab bucket comprising girders, bucket segments pivotally carried by the

girders, a closing member having inclined surfaces slidably mounted between the girders, and means connecting the closing member with the bucket segments.

5 2. A grab bucket comprising girders, bucket segments pivotally carried by the girders, a closing member having inclined surfaces slidably mounted between the girders, closing arms carried by the bucket
10 segments, and rollers carried by the arms and engageable with the inclined surfaces of the closing member.

3. A bucket comprising girders, bucket segments, pivotally carried by the girders, guides carried by the girders, a closing member, the closing member having guide ways
15 slidably disposed between the guides, inclined surfaces provided on the closing member, closing arms carried by the bucket segments, and rollers carried by the arms, the

rollers being engageable with the inclined surfaces of the closing member.

4. A bucket comprising girders, bucket segments, pivotally carried by the girders, guides carried by the girders, a closing member, the closing member having guide ways
25 slidably disposed between the guides, the closing member being provided with a central inclined surface, side inclined surfaces, one arranged on each side of the central surface, the central surface being inclined oppositely to the side surfaces, closing arms
30 carried by the bucket segments, and rollers carried by the arms, the rollers being engageable with the inclined surfaces of the closing member.

In testimony whereof, I have hereunto signed my name.

EPHREM PREFONTAINE.