

Sept. 4, 1928.

W. S. HADAWAY, JR
STEAM PRESS FOR CLOTHES

1,682,903

Filed April 11, 1923

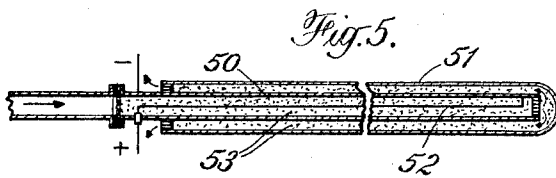
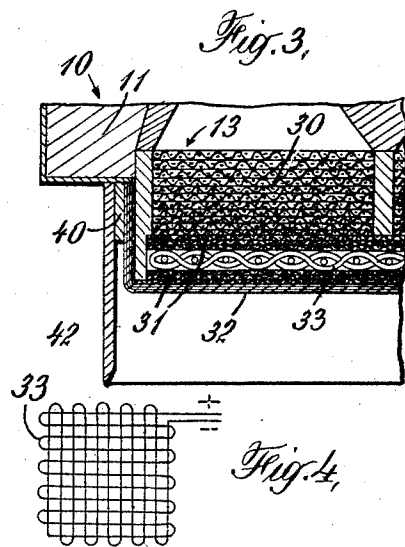
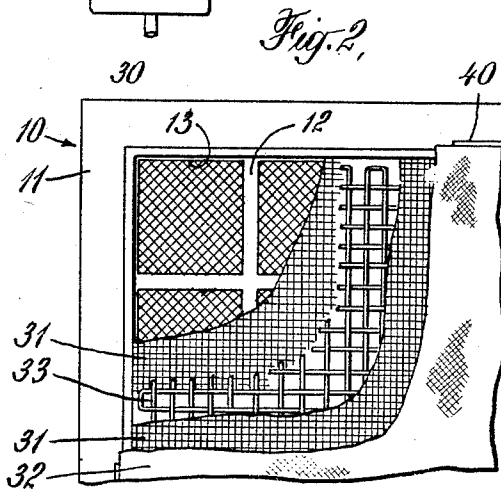
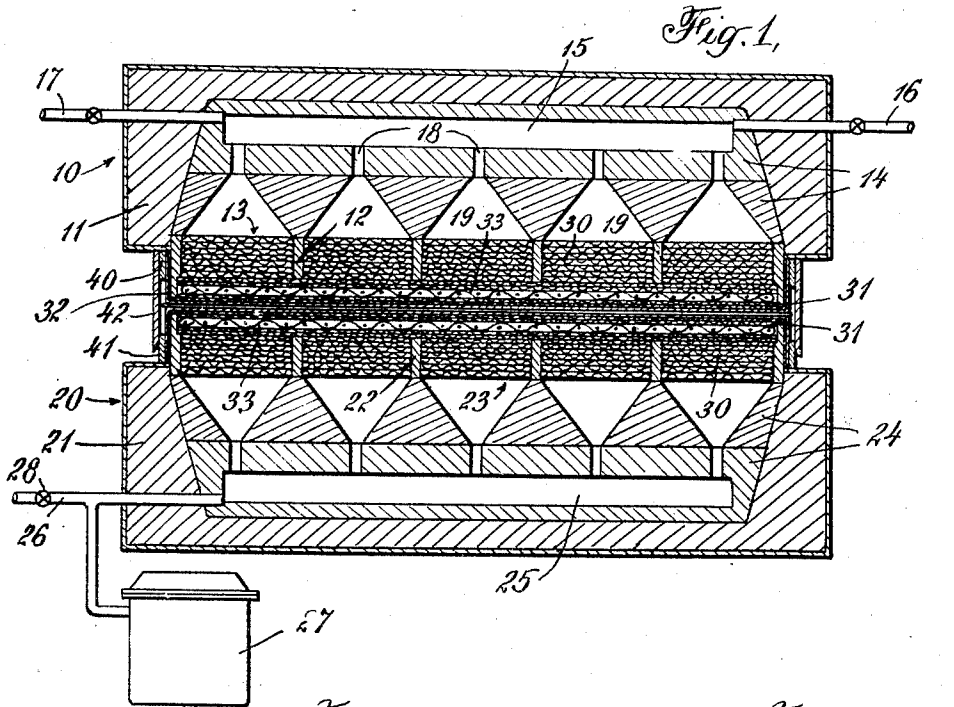

INVENTOR
Wm. S. Hadaway, Jr.
BY *E. W. Marshall*
ATTORNEY

UNITED STATES PATENT OFFICE.

WILLIAM S. HADAWAY, JR., OF NEW ROCHELLE, NEW YORK.

STEAM PRESS FOR CLOTHES.

Application filed April 11, 1923. Serial No. 631,382.

My invention relates to new and useful improvements in laundry and garment presses and the like in which steam or hot vapor is used as a heating agent, either along, or in conjunction with an auxiliary heating agent such as electricity, and to a novel method of pressing and finishing clothes. Its object is to provide a simple machine for steaming and pressing articles without the use of absorbent pads with their attendant undesirable effects, and by which the pressing operation may be accomplished more quickly and by which the intervals between successive operations may be shortened.

Another object is to provide an apparatus by which the article acted upon may be moistened and dried almost instantly and in which the pressing elements remain dry.

A more specific object is to provide an apparatus which is arranged to utilize steam at different temperatures and also to provide an auxiliary electric heating element which may be used if desired.

Another object of this invention is to provide an improved method of pressing and finishing which removes some of the difficulties encountered in such methods as have been known heretofore.

Further objects of the invention will appear from the following description taken in connection with the drawings which form a part of this application and in which,

Fig. 1 is a sectional elevation of a steam press for clothes which is made in accordance with this invention.

Fig. 2 is an enlarged plan view of a portion of one of the press elements with various layers thereof broken away in order to show more clearly its construction.

Fig. 3 is a sectional elevation of the upper press element which is drawn on an enlarged scale in order to show more clearly its construction.

Fig. 4 is a plan view of an electric heater which may form a part of this application.

Fig. 5 is a sectional elevation on an enlarged scale of a heater element arranged to be energized by a heating fluid and electricity, which may be used for the construction of a heater of modified form.

Like characters of reference designate corresponding parts in all of the figures of the drawings.

10 designates an upper press member and 20 a lower press member of somewhat simi-

lar construction. These members are, as shown, so placed that corresponding parts of each are arranged to coact. These members are relatively movable and for the sake of explaining this invention it will be assumed that the lower member 20 is stationary and that the upper member 10 is capable of being moved vertically away from and back to the other. Each of these members comprises a frame 11 and 21 respectively, having webs 12 and 22 respectively, which webs divide the frames into relatively small openings, which in this case as clearly shown in Fig. 2, are rectangular and are designated by the reference characters 13, 23. Secured to each of the frames at the back thereof are distributing members 14, 24 forming chambers 15, 25. To the chamber 15 steam or hot vapor may be supplied either through valve controlled pipe 16 or through a similar pipe 17. One of these, such as 16, is connected preferably with a supply of low temperature dry steam and the other 17 is connected with a source of superheated steam at a higher temperature. This steam is arranged to pass through a plurality of passages 18 into and through flaring openings 19 communicating respectively with the chambers 13.

The spaces or chambers 13 and the similar spaces 23 on the lower press member are filled with masses 30 of wire screen or some other suitable porous structure through which the hot vapor may percolate. Beyond the webs 12 and 22 wire screens 31 or the like are stretched over the entire frames 10 and 20 and outside of the wire screens are cloth covers 32. These are not the equivalent of the pads which are usually employed in structures of this same general character as they are very thin and have no moisture absorbing property. Interposed between the screens 31 of the upper press member is an electric heater 33 which may be in the form of an open mesh as shown in Fig. 4 so that it is porous.

If desired, the auxiliary heater may be constructed to utilize both a hot fluid and electricity in the manner disclosed in Patent No. 1,468,106 issued September 18, 1923, on an application copending herewith. A part of a structure of this kind is shown in Fig. 5 in which 50 is an inner metallic tube arranged to conduct a heating fluid such as steam into the element and from one end to the other thereof, and 51 is an outer tube

forming a return passage therefor. 52 is a resistance wire extending from the inlet end of the inner tube to its opposite end where it is electrically connected thereto, so that the wire 52 and the inner tube 50 together form a path for electricity. The wire is spaced from the inner tube and the tubes are spaced from each other by a granular filler 53.

The details of the structure of the upper press member 10 is clearly brought out in Figs. 2 and 3, and it is to be understood that the lower press member is of similar construction with the exception that the lower press member 20 is provided with no steam supply pipes, but from its chamber 25 leads an outlet pipe 26 connected directly to a steam trap 27. There is also a valve 28 in the outlet pipe 26 which when opened permits the steam from chamber 25 to pass directly into the atmosphere.

As shown in the drawings, I prefer to utilize screens of coarser mesh at the back or away from the pressing surface and to build up finer and finer mesh screens with the small openings and the consequently smoother surfaces of the outer screens. The outer screens may, if desired, form the working surfaces of the press members, or if a non-metallic surface is desired, a sheet of cloth or the like, designated by 32 and of desired texture, dependent upon the use to which the press is to be put, may be utilized.

Around the edges of the upper press member 10 is a band 40 and a similar band 41 is placed around the edges of the lower press member 20 to hold the outer covers such as 32, in place. 42 is a flexible apron which depends from the band 40 and is arranged to overlap the band 41 and form a steam-tight closure therewith when the two press members are brought into proximity.

When not in use the two press members may be brought together and low temperature steam admitted through pipe 16 allowed to percolate through the porous mass of the upper press member and down through the porous mass of the lower press member. This steam will then escape through the pipe 26 into the steam trap 27, or, in case the valve 28 is open, directly into the atmosphere. In this manner the press members may be kept hot for the purpose of expediting the operation of pressing.

When it is desired to press any article by the use of this apparatus, the steam supply is cut off and the upper press member raised up from the lower press member. The article is then placed on the upper surface of the lower press member, the upper press member brought down against it and steam admitted either through the pipe 16 or through the pipe 17.

When the steam first comes in contact with the article some of it condenses and

moistens the article as in former practice of finishing. But, in this case, the flow of steam is continued down into and through the lower press member and takes up and carries off all moisture. Both press members have high heat capacities and thus assist the drying. If the article pressed is so thick that it condenses an undue amount of moisture, the drying action may be accelerated by using superheated steam. This may be obtained by energizing the electric heater 33, or by admitting superheated steam through pipe 17, or both.

It is customary to dampen the articles before they are pressed and finished, and if this is done, the operation may be performed by the use of hot air instead of steam. It is obvious that the apparatus may be made and used without the auxiliary or electric heaters, and that an electric heater may be provided in only the inlet heater member, but in some cases it may be preferred to provide an auxiliary or electric heater in each of the press members for the reason set forth in the following paragraph.

After a pressing and finishing operation, the fluid heat supply is shut off and the press members separated. At the moment of separation there is a tendency for the steam in the members to escape through the porous pressing surfaces which at the same time are exposed to the cooler temperature of the surrounding atmosphere. This might cause some condensation to take place on these surfaces. The porous masses are constructed of material having a considerable heat capacity and the latent heat therein counteracts this tendency toward condensation. The auxiliary heaters, when supplied, may remain energized when the press members are separated to further dissipate any condensed moisture and to assist in keeping the press members dry.

The construction and method of heating the pads shown and described herein was fully set forth in Patent No. 1,551,149 issued to me August 27, 1925, the application for which was copending herewith and was divided, certain features of the original disclosure being covered in Patent No. 1,610,515 issued to me December 14, 1926, and other features of this original disclosure being embodied in this present application.

This invention is capable of being embodied in other structures than that shown for purposes of illustration and the novel method of pressing clothes herein disclosed may be performed with many other kinds of apparatus and therefore I intend no limitations other than those imposed by the appended claims.

What I claim is:

1. In apparatus of the character described, a pair of hollow press members having cooperating surfaces arranged to receive an

article between them, a porous mass of heat retaining material in each of said members and means for passing a current of hot gaseous medium into one of the members through said cooperating surfaces an article between said surfaces and out through the other member.

2. In apparatus of the character described, a pair of hollow relatively movable press members having cooperating surfaces arranged to receive an article between them, a porous mass of heat retaining material in each of said members, means for surrounding and enclosing said surfaces when the members are near each other, and means for passing a current of hot gaseous medium into one of the members through said cooperating surfaces an article between said surfaces and out through the other member.

3. In apparatus of the character described, a pair of hollow press members having cooperating surfaces arranged to receive an article between them, a porous mass of heat retaining material in said members, means for passing a current of hot vapor into one of the members through said cooperating surfaces an article between said surfaces and out through the other member, and an auxiliary heater in that member into which the steam is first passed.

4. In apparatus of the character described, a pair of hollow press members having cooperating surfaces arranged to receive an article between them, a porous mass of heat retaining material in said members, means for passing a current of hot vapor into one of the members through said cooperating surfaces an article between said surfaces and out through the other member, and an auxiliary heater in that member into which the hot vapor is first passed near its said surface.

5. In apparatus of the character described, a pair of hollow press members having cooperating surfaces arranged to receive an article between them, a porous mass of heat retaining material in said members, means for passing steam at unlike temperatures into one of the members through said cooperating surfaces and out through the other member, and an auxiliary heater in that member into which the steam is first passed.

6. In an apparatus of the character described, a pair of hollow press members, a plurality of substantially parallel wire screens and a permeable electric heater in at least one of said members, and means for passing a current of hot vapor through one of the members and out through the other member.

7. In an apparatus of the character described, a pair of hollow press members, a plurality of substantially parallel wire screens in said members, means for passing a current of hot vapor through one of the members and out through the other member,

a permeable electric heater in at least one of the members substantially parallel with the wire screens therein.

8. In an apparatus of the character described, a pair of relatively movable hollow press members having cooperating surfaces arranged to receive an article between them, a plurality of substantially parallel wire screens of unlike size mesh in said members, the finer screens being placed near the cooperating surfaces, an electric heater parallel with said screens in at least one of the members, means for surrounding and enclosing said surfaces when the members are near each other, and means for passing a current of hot vapor into one of the members, through said cooperating surfaces an article between said surfaces and out through the other member.

9. In an apparatus of the character described, a pair of relatively movable hollow press members having cooperating surfaces arranged to receive an article between them, a plurality of substantially parallel wire screens of unlike size mesh in said members, the finer screens being placed near the cooperating surfaces, a permeable electric heater in at least one of the members between adjacent screens near said surface and substantially parallel with the screens, means for surrounding and enclosing said surfaces when the members are near each other, and means for passing a current of hot vapor into one of the members, through said cooperating surfaces an article between said surfaces and out through the other member.

10. In an apparatus of the character described, a pair of relatively movable hollow press members having cooperating surfaces arranged to receive an article between them, a plurality of substantially parallel wire screens of unlike size mesh in said members, the finer screens being placed near the cooperating surfaces, a permeable electric heater, in the members between the adjacent screens near said surfaces and substantially parallel with the screens, means for surrounding and enclosing said surfaces when the members are near each other, and means for passing a current of hot vapor into one of the members, through said cooperating surfaces an article between said surfaces and out through the other member.

11. A press member comprising a vapor chamber having a discharge opening, a porous mass in said opening, said mass comprising a plurality of closely assembled substantially parallel wire screens and an auxiliary heater interposed between said screens.

12. A press member having a pressing surface, said member comprising a vapor chamber having a discharge opening, a porous mass in said opening, said mass comprising a plurality of closely assembled substantially parallel wire screens of unlike size mesh, the

finer screens being placed near the pressing surface, and a permeable electric heater between and parallel with said screens.

5 13. A press member having a pressing surface, said member comprising a vapor chamber having a discharge opening, a porous mass in said opening, said mass comprising a plurality of closely assembled substantially parallel wire screens of unlike size mesh, the
10 finer screens being placed near the pressing surface, and a permeable electric heater near said pressing surface, between and parallel with said screens.

15 14. In an apparatus of the character described, a pair of hollow press members, vapor conduits and a plurality of substantially parallel screens in each of said members, means for passing hot vapor into one
20 of the members through the screens in both members and out through the other member,

and a permeable electric heater in that one of the members into which the hot vapor is first passed substantially parallel with the wire screens therein.

25 15. In an apparatus of the character described, a pair of hollow press members, vapor conduits and a plurality of substantially parallel screens in each of said members, means for passing hot vapor into one
30 of the members through the screens in both members and out through the other member, and a permeable electric heater in that one of the members into which the hot vapor is first passed substantially parallel with the
35 wire screens therein at the side thereof which is opposite the conduit through which the hot vapor is introduced.

In testimony whereof, I have hereunto set my hand this 10th day of April, 1923.

WILLIAM S. HADAWAY, JR.