

I. H. JEWELL.
 STILL.
 APPLICATION FILED JUNE 18, 1909.

999,793.

Patented Aug. 8, 1911.

2 SHEETS—SHEET 1.

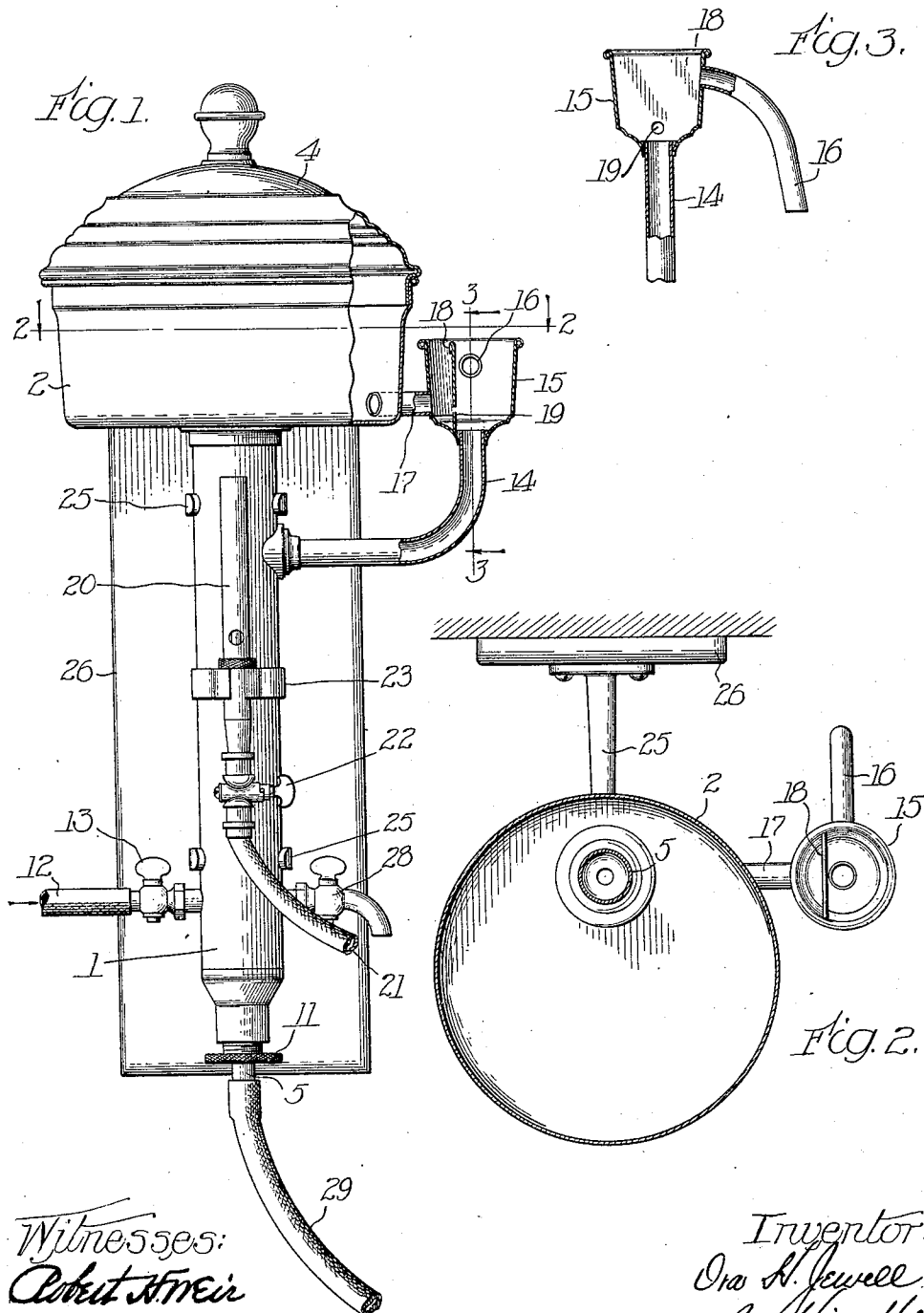

Witnesses:
Robert H. Meier
Harold Barrett

Inventor:
Ora H. Jewell
 By *W. H. Hill*
attor.

I. H. JEWELL.
 STILL.
 APPLICATION FILED JUNE 18, 1909.

999,793.

Patented Aug. 8, 1911.

2 SHEETS—SHEET 2.

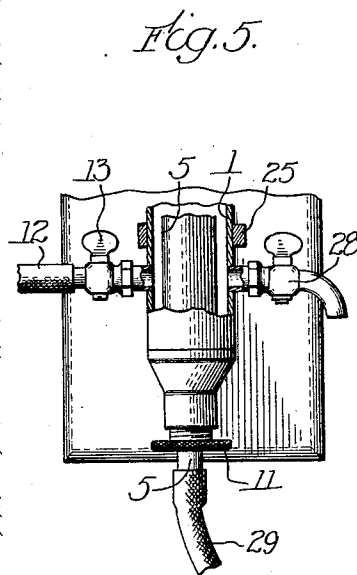
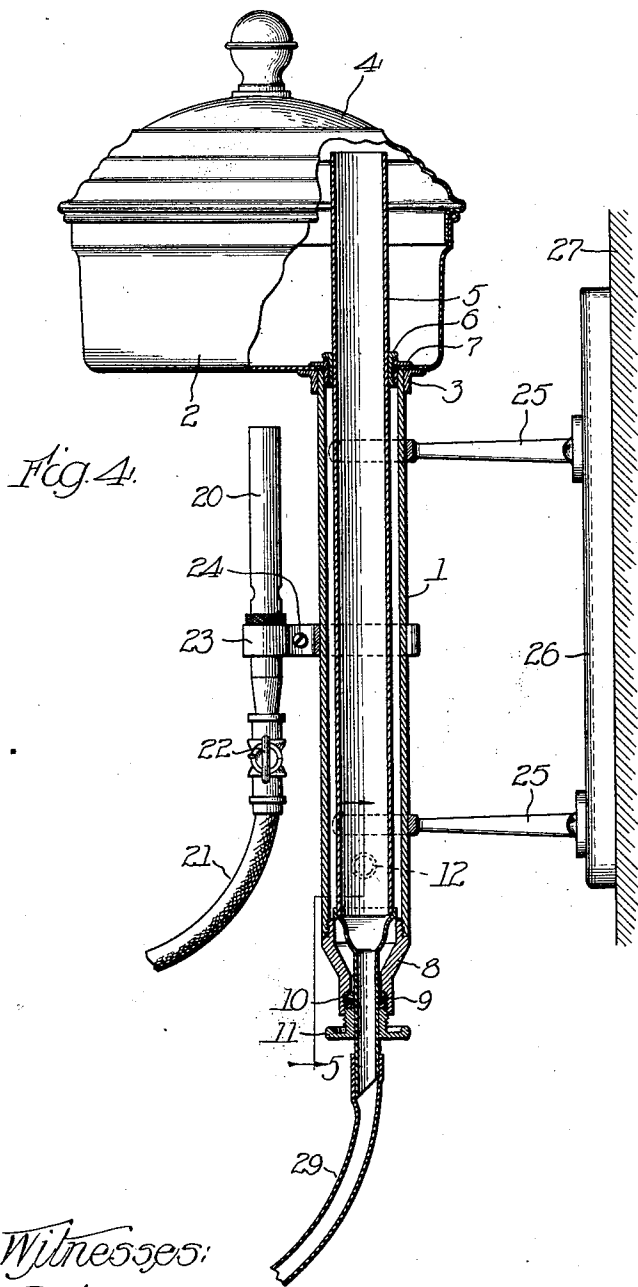

Witnesses:
 Robert H. Meir
 Harold L. Barrett

Inventor:
 Ira H. Jewell
 By Hill & Hill
 Attys

UNITED STATES PATENT OFFICE.

IRA H. JEWELL, OF CHICAGO, ILLINOIS.

STILL.

999,793.

Specification of Letters Patent.

Patented Aug. 8, 1911.

Application filed June 18, 1909. Serial No. 502,862.

To all whom it may concern:

Be it known that I, IRA H. JEWELL, a citizen of the United States, residing at Chicago, in the county of Cook and State of Illinois, have invented certain new and useful Improvements in Stills or the Like, of which the following is a description.

My invention belongs to that class of devices known as "stills" or distilling apparatus, and relates particularly to a device for producing distilled water.

The invention has among its objects the production of a simple, efficient, compact, attractive and satisfactory device of the kind described, at a comparatively small cost, for use wherever found applicable.

To this end my invention consists in the novel construction, arrangement and combination of parts herein shown and described, and more particularly pointed out in the claims.

Referring to the drawings in which like reference characters indicate like or corresponding parts: Figure 1 is a front elevation and partial sectional view of the preferred form of my device. Fig. 2 is a cross sectional view of the same taken substantially on line 2—2 of Fig. 1. Fig. 3 is a sectional view taken substantially on line 3—3 of Fig. 1. Fig. 4 is a side elevation and partial sectional view of the device; and Fig. 5 is a sectional view taken substantially on line 5—5 of Fig. 4.

Referring to the drawings in which my preferred form of device is shown, 1 is a tube of suitable shape and material, provided with a receptacle or boiler 2 at one end thereof. In use the apparatus is preferably set up with the tube in a vertical position and the boiler arranged at the upper end thereof. The tube 1 and boiler 2 may be secured together in any suitable way, preferably by brazing the two together, a suitable reinforcement 3 being provided, as shown, if desired. The boiler may be of any suitable shape or design, but is preferably made cylindrical and of equal diameter throughout its height, the same being provided with a suitable cover 4, arranged to be tightly positioned thereon.

Within the tube 1, and spaced therefrom, is arranged what may be termed, a condensing tube 5, the same forming a condensing chamber, the tube 5 preferably extending

from both ends of the outer tube 1, with the upper end in the boiler, and extended above the normal level of the fluid contained therein. The condensing tube 5 may be secured in position in any suitable manner and provided with any suitable packing material. As shown it is provided with a threaded flange 6, arranged to engage a threaded flange 7 arranged on the upper end of the tube 1. At the lower end 8 of the outer tube where the condensing tube passes through is arranged suitable packing material 9, which is held in place and expanded by means of a washer 10 and a threaded nut 11. In this construction the two tubes form a water jacket about the condensing chamber and the condensing tube, and while rigidly secured in position at both ends, may be readily removed for any desired purpose, for instance, to clean the device. Any other equivalent or suitable arrangement may be provided for securing the condensing tube 5 in position and closing the ends of the water-jacket space.

The water jacket is provided with a suitable inlet 12 preferably arranged near one end thereof, as shown proximate to the lower end, and with a suitable outlet 14, preferably arranged at the other end, as shown proximate to the top. Any suitable form of valve 13 may be employed to control the water or fluid admitted to the water jacket. The outlet in the preferred construction is arranged to communicate with the interior of the boiler and feed the same, and maintain a suitable constant water level therein. In the construction shown the outlet 14 is enlarged or provided with what may be termed a cup 15, arranged therein with a suitable overflow or waste pipe 16, arranged to conduct the overflow to a sewer, or wherever it is desired. As shown a tube or pipe 17 connects the cup or outlet with the boiler, forming an inlet therefor, which may enter the boiler at the side as shown or below it, the preferred construction being to have the inlet to the boiler as near the bottom of the same as possible. Within the cup 15 is arranged a partition 18 extending above the waste outlet 16, provided with an opening 19 therethrough preferably arranged near the bottom of the partition. The normal outlet or overflow opening 16 for the cup 15 is arranged at the

point where it is desired to have the water level in the boiler, so that while a great portion of the water flows out through the waste pipe an amount sufficient to keep the water level in a line with the waste pipe will pass through the opening 19 in the partition through the pipe 17 to the boiler, thereby maintaining a substantially constant level in the same.

Any suitable means may be employed to heat the water in the boiler sufficiently to distil the same or convert it into steam. As shown a gas burner 20 is provided for the purpose, the gas being conducted to the burner through a suitable pipe or tube 21, the same being controlled by a valve 23, or its equivalent. Any suitable means may be employed for securing the burner in position, a very simple construction comprising a two part clamp 23 embracing the tube 1 and engaging at the back thereof, a screw 24 or its equivalent being provided for drawing the parts of the clamp together and securely retaining the burner in position. It is of course obvious that any suitable means may be employed for supporting the apparatus. As shown, a plurality of arms 25 carried by a block 26 embrace the tubes, the block being secured to the wall 27 or to where desired.

A small valve or drain cock 28 may be arranged at the lower end of the water jacket to serve as a drain, it being obvious that when the water to the inlet is turned off and the drain opened the water in the boiler and water jacket will drain out through the drain-cock. The boiler and water jacket may also be drained by removing the condensing tube 5 so that the water may flow out through the lower end 8 of the outer tube 1.

In operation the inlet valve 13 being open the water enters through the inlet pipe 12 and flows through the water jacket and up into the cup 15, a portion entering the boiler, thereby maintaining a constant water level and the excess water passing out through the waste pipe 16. The burner under the boiler being lighted, the water in the boiler is converted into steam and passes up and into the condensing tube 5, where it is condensed, the cold water passing through the water jacket maintaining the walls of the condensing chamber cold. The condensed steam or distilled water passes through the condensing tube and out through the lower end thereof into a suitable receptacle providing for receiving the same. The water level in the boiler is maintained at the same level at all times since water will enter through the inlet pipe 17 whenever the water level drops below the waste pipe opening. When the water is turned off the valve 13 may be shut, shutting off the supply of water.

Having thus described my invention, it is obvious that various immaterial modifications may be made in the form, construction, arrangement, and combination of parts or uses shown, described or mentioned, without departing from the spirit of my invention; hence I do not wish to be understood as limiting myself to the exact construction, arrangement, combination of parts or uses mentioned, shown or described.

What I claim as new and desire to secure by Letters of Patent is:—

1. In an apparatus of the character described, the combination of a condensing tube, a water jacket surrounding and spaced from the condensing tube which latter projects beyond the ends of the water jacket, a boiler having an eccentrically arranged opening in its bottom for the passage of the condensing tube which latter projects within the boiler above the water line thereof, the wall of the boiler surrounding the eccentric opening resting upon the water jacket by which the boiler is supported, a heater and means carried by the water jacket for supporting the heater, whereby the flame is directed substantially centrally of the supported boiler, and a conduit leading from the water jacket at a point adjacent the upper end thereof and terminating in an enlarged cup shaped member having an overflow opening adjacent its top which latter constitutes the water level of the water in the boiler, a transversely extending conduit adjacent the bottom of said cup-shaped receptacle and communicating with the interior of the boiler through one side thereof adjacent its bottom, an apertured partition arranged within the cup shaped receptacle intermediate the overflow outlet thereof and the last mentioned conduit, and an inlet adjacent the lower end of the water jacket.

2. In an apparatus of the character described, a vessel having a removable top, an elongated condensing tube projecting through the bottom of the vessel to a point adjacent the upper end thereof and having a water tight joint with the bottom of the vessel and being open at its upper end, the tube being eccentrically arranged relatively to said vessel, and having a conduit leading from the lower end thereof, a casing surrounding the tube and spaced from the latter, said casing being connected at its upper end to the bottom of the vessel and at its lower end to the conduit leading from the lower end of the tube, a bracket sleeved upon the casing intermediate its ends, a burner mounted upon the bracket so as to be positioned substantially centrally of the bottom of the vessel, a valve controlled inlet for the burner, a valve controlled inlet adjacent the lower end of the casing, and an oppositely disposed valve controlled outlet also adjacent the lower end of said cas-

ing, a cup shaped receptacle positioned to one side of said vessel, a conduit leading from the vessel to said receptacle, a conduit leading from said receptacle to the casing, and a diaphragm in the receptacle intermediate the conduits leading from the receptacle.

In testimony whereof, I have hereunto signed my name in the presence of two subscribing witnesses.

IRA H. JEWELL.

Witnesses:

JOHN McCLURE,
BEN M. GEROUX.

Copies of this patent may be obtained for five cents each, by addressing the "Commissioner of Patents, Washington, D. C."