



(11) **EP 2 808 434 B1**

(12) **EUROPEAN PATENT SPECIFICATION**

(45) Date of publication and mention of the grant of the patent:  
**11.05.2016 Bulletin 2016/19**

(51) Int Cl.:  
**D06F 37/28<sup>(2006.01)</sup> D06F 39/14<sup>(2006.01)</sup>**

(21) Application number: **13169933.2**

(22) Date of filing: **30.05.2013**

(54) **Laundry treatment device with door assembly**

Wäschebehandlungsvorrichtung mit Türanordnung

Dispositif de traitement du linge avec ensemble de porte

(84) Designated Contracting States:  
**AL AT BE BG CH CY CZ DE DK EE ES FI FR GB GR HR HU IE IS IT LI LT LU LV MC MK MT NL NO PL PT RO RS SE SI SK SM TR**

(43) Date of publication of application:  
**03.12.2014 Bulletin 2014/49**

(73) Proprietor: **Electrolux Appliances Aktiebolag**  
**105 45 Stockholm (SE)**

(72) Inventors:  
• **Bottosset, Roberto**  
**33080 Porcia (PN) (IT)**

• **De Pellegrin, Andrea**  
**33080 Porcia (PN) (IT)**

(74) Representative: **Frare, Paolo et al**  
**Electrolux Italia S.p.A.**  
**Corso Lino Zanussi, 30**  
**33080 Porcia (PN) (IT)**

(56) References cited:  
**EP-A1- 2 105 527 EP-B1- 1 463 856**

**EP 2 808 434 B1**

Note: Within nine months of the publication of the mention of the grant of the European patent in the European Patent Bulletin, any person may give notice to the European Patent Office of opposition to that patent, in accordance with the Implementing Regulations. Notice of opposition shall not be deemed to have been filed until the opposition fee has been paid. (Art. 99(1) European Patent Convention).

## Description

### Field of the invention

**[0001]** The present invention relates to a laundry treatment device, in particular to a washing machine, a dryer or a washer/dryer, i.e. a washing machine having also dryer functions, comprising a door assembly and a holding device capable of preventing the opening of the door assembly when the laundry treatment device is operating or under other predetermined conditions.

### Background of the invention

**[0002]** Conventionally, laundry treatment devices include a casing within which a laundry treatment chamber, typically formed by a drum, is located. In the casing an opening is formed, allowing the user to have access to the treatment chamber in order to load or unload the laundry before and after the washing and/or drying cycle(s). In order to close the treatment chamber, laundry treatment devices further comprise a door assembly, typically pivotally associated to the casing.

**[0003]** Laundry treatment devices are also provided with a locking device for keeping the door assembly locked, and consequently closing the treatment chamber, during washing and/or drying cycle(s). Typically, such locking device comprises a hook, associated to the door assembly, engaging a respective hole or seat provided in the casing when the door is in its closed position.

**[0004]** When required, the door assembly can be opened, typically by means of a handle which can be rotated for disengaging the hook from the hole or seat. As an alternative, the hook and/or the hole or seat could be shaped such that when the door is pulled sufficiently it is automatically disengaged.

**[0005]** Although necessary for the loading/unloading operations, opening the door assembly when the appliance is in operative conditions, e.g. during a washing cycle, could be dangerous, since it could result, for example, in an uncontrolled water discharge from the treatment chamber or in even more hazardous situations.

**[0006]** In order to avoid this risk, some known laundry treating appliances are provided with devices capable of holding the hook in a locked position during the operative conditions of the appliance (i.e. during a washing cycle, a drying cycle, etc.).

**[0007]** For example, EP 1463856 discloses a washing machine and a dryer having a door assembly including a hinge assembly, a door body, a hook assembly and a lock assembly. The lock assembly is provided to a cabinet of the washing machine to hold the hook and it includes a hook holding device and a locking device. The hook holding device holds the hook by using an elastic force of the hook when the hook is inserted therein, and releases the hook when the hook is drawn. The locking device, operative in response to an external electric signal, maintains the held state of the hook for preventing

a door body from being forcibly opened by an external force.

**[0008]** A further example of laundry treatment device is shown in WO 03/004754, disclosing a washing machine comprising a door with a locking mechanism. The locking mechanism comprises a handle; a lock that performs the locking function and which is designed to fit into the locking space provided in the machine cabinet, a hook cover to fix the hook when the door is closed and a lock protector with a structure suitable to the locking mechanism. The lock protector comprises a lock socket, one or more fastening projections and one or more cable outlets.

**[0009]** It is evident that, in order to ensure a proper operation of such holding devices, it is required that the cables providing the electric signal are correctly plugged to the device.

**[0010]** Nevertheless, during manufacturing of washing machines or driers or washer/driers, the step of connecting such cables is often complicated; this drawback is worsened since, typically, the end portion of the cables, connected to the lock holding device, is enclosed by a protective shell, which, once assembled, prevents verifying the correct connection of the cables to the lock holding device.

**[0011]** This drawback is even more relevant when the connection is obtained by means of plug-and-socket type connector, since a proper and complete insertion of the plug cannot be easily acknowledged.

**[0012]** Furthermore, it should be noted that, even after the assembly of a laundry treatment device, the cables - connected by means of such plug-and-socket type connector - can be accidentally pulled (for example during the transport of the device), thus again impairing the electric connection of the lock holding device.

**[0013]** Similarly, a partial withdrawal of the connector plug from the socket could also be caused by the vibrations generated during operation of the laundry treatment device. Also in this case, the partial withdrawal of the plug could result in an improper working of the laundry treatment device.

### Summary of the invention

**[0014]** An object of the invention is to provide a laundry treatment device that overcomes the drawbacks of known laundry appliances provided with holding devices for holding the lock of the door assembly in a closed position.

**[0015]** A further object is to provide a laundry treatment device in which the proper connection of the cables for operating the holding device is guaranteed even during and after the manufacturing of the device.

**[0016]** Furthermore, it is also an object of the present invention to provide a laundry treating device comprising an electric connector which is not subjected to the risk of disconnection caused by vibrations generated for example during transport or operation of the device.

**[0017]** According to the invention it is provided a laundry treatment device comprising:

- a casing enclosing a treatment chamber for receiving a load to be treated, the casing comprising an aperture for allowing access to the treatment chamber;
- a door assembly mounted on the casing for opening and closing the aperture;
- a lock assembly of said door assembly;
- a holding device of the lock assembly capable of holding the lock assembly in a closed position under predetermined conditions, the holding device being connected or connectable by means of electric wires to a control unit;
- a first connector element for electrically connecting the wires to the holding device;
- a cover member at least partially covering the first connector element and/or said holding device;

wherein the cover member comprises an abutment surface abutting on the first connector element when the wires are electrically connected to the holding device.

**[0018]** It is to be understood that in the laundry treatment device according to the invention, the presence of the abutment surface abutting against the connector element, through which the electric wires are connected, prevents accidental displacement of the connector element from the holding device.

**[0019]** Accordingly, a proper electric connection of the holding device can be verified by the position of cover member which position can be easily controlled during the assembly of the laundry treating device.

**[0020]** In fact, during assembly of the laundry treatment device, when the cover member is fixed to the holding device it is brought closer thereto. During such movement, if the first connector element is not correctly positioned, the abutment surface urges against the first connector element. The interaction between the abutment surface and the first connector element can result into two different situations:

- if the first connector element is correctly aligned with a plugging direction thereof, and the movement required for fixing the cover member to the holding device generates a movement of the connector element along the plugging direction, then the urging of the abutment surface brings the first connector element in a correct connected position;
- if the first connector element is not correctly aligned with the plugging direction thereof, then the contact between the abutment surface and the first connector element prevents the fixing of the cover member to the holding device, thus allowing an immediate acknowledgment of the improper connection of the first connector element.

**[0021]** Furthermore, once the cover member is fixed

to the holding device, any displacement of the first connector element is advantageously avoided, thus guaranteeing a proper connection even in case of accidental pulling of the wires. Similarly, also vibrations generated by the operation of the laundry treating device do not cause any risk of impairing the electric connection of the holding device.

**[0022]** According to a preferred embodiment, in the laundry treatment device according to the present invention the holding device comprises a second connector element connected or connectable to the first connector element. The first connector element is positioned, in use, between the abutment surface and the second connector element.

**[0023]** This advantageously makes the assembly of the holding device easier since it allows connecting the connector after the holding device has been fixed to the laundry treating device.

**[0024]** Preferably, the first and second connector elements comprise a plug and a respective socket, the first and second connector elements being connectable by inserting the plug in the socket along a plugging direction.

**[0025]** In this manner, a proper electric connection of the holding device can be easily and effectively verified by controlling the position of plug along said plugging direction.

**[0026]** According to a further preferred aspect, the abutment surface abuts on a respective surface of the first connector when connected to the second connector so that movements of said first connector along a direction opposed to said plugging direction are prevented. This advantageously allows keeping the first and second connectors connected as long as the cover member, and therefore the abutment surface, is fixed to the holding device.

**[0027]** Always according to a preferred embodiment, the abutment surface is formed on a respective rib projecting from a cover surface of said cover member. Accordingly, the rib and the abutment surface can be advantageously formed on the cover member in a very simple and inexpensive manner, e.g. by means of plastic molding.

**[0028]** According to a further aspect of the invention, the cover member advantageously comprises a casing at least partially enclosing the holding device, the rib being formed inside the casing.

**[0029]** The presence of a casing in the present invention allows improving the protection of the connector element of the holding device, while at the same time avoiding any risk of improper connection of wires.

**[0030]** Preferably, an opening is provided in said casing, said opening facing away from the plugging direction, thus advantageously allowing the passage of the wires for the electric connection of the holding device.

**[0031]** In this manner the wires advantageously develop according a curved line, defining a bend advantageously positioned, when the cover member is fixed to the holding device, below the connector element. As a

consequence, if a drop of water (e.g. caused by condensation or by minimal spillages of water for the hydraulic system of the laundry treatment device) wets the wire, it will run on the wire for the action of gravity stopping at said bend. Accordingly, the features of this embodiment avoid drops of water reaching the connector element.

**[0032]** According to a preferred embodiment, the cover member comprises an extension through which the wires pass. The casing of the cover member is advantageously separated from the extension by a dividing wall, thus creating a barrier against drops of water falling from the wires above the connector element.

**[0033]** According to a preferred embodiment, the cover member comprises a fastening device for removably fixing the cover member to the holding device. This makes it possible to keep the cover member in a fixed position with respect to the holding device, while at the same time providing the capability of removing it, e.g. for maintenance purposes.

**[0034]** Preferably, the cover member is fastened to the holding device by moving the cover member towards the holding device along said plugging direction. In this manner while the cover member is fastened to the holding device, the abutment surface abuts on the connector element, thus advantageously plugging it if not properly plugged.

**[0035]** According to a preferred embodiment, the fastening device comprises a (preferably wedge-shaped) projection and a receiving opening for the projection, formed one on the holding device and the other on the cover member. Even more preferably, the projection is slanted towards a direction opposed to said plugging direction; preferably the receiving opening is formed on a flexible flap of the holding device.

**[0036]** This structure allows providing an easy and inexpensive fastening of the cover member, which can be advantageously obtained by means of a snap connection.

**[0037]** According to a further aspect of the invention, the cover member comprises first and second fastening devices. The first and second fastening devices are formed on opposite surfaces of the cover member, thus improving the stability of the cover member when fixed to the holding device.

**[0038]** According to another aspect of the invention, the cover member comprises at least two abutment surfaces separated therebetween. In this manner a same cover member can be used for holding devices of different shapes.

**[0039]** Still according to a preferred embodiment, the cover member comprises wire clips capable of holding the wires. This advantageously makes it possible to hold the wires on the cover member before fixing it to the holding device.

#### Brief description of the drawings

**[0040]** These and other features and advantages of

the invention will be better apparent from the following description of some exemplary and non-limitative embodiments, to be read with reference to the attached drawings, wherein:

- 5 - Fig. 1 is a perspective view, with a door assembly in an open configuration, of a laundry treatment device according to the present invention;
- 10 - Fig. 2 is a rear perspective view of a front bulkhead of the laundry treatment device of the present invention;
- 15 - Fig. 3 is partially sectional perspective view of a holding device, a cover member and a connector of the laundry treatment device according to the present invention;
- 20 - Fig. 4 is an exploded perspective view the holding device, the cover member and the connector of Fig. 3;
- 25 - Fig. 5 is a partially sectional front view of a holding device, a cover member and a connector of the laundry treatment device according to a second embodiment of the present invention; and
- 30 - Fig. 6 is an exploded perspective view the holding device, the cover member and the connector of Fig. 5.

#### Detailed description of the invention

**[0041]** With reference initially to Fig. 1, a laundry treatment device realized according to the present invention is globally indicated with the reference number 100.

**[0042]** It should be noted that in the context of the present invention with the term laundry treatment device it is to be intended any type of appliance suitable for the treatment of laundry, such as washing machines, tumble-dryers or washer/dryers, i.e. a washing machines having also dryer functions.

**[0043]** The laundry treatment device 100 comprises an outer casing 101, preferably but not necessarily parallelepiped-shaped, and a treatment chamber, such as a drum 102, for example having the shape of a hollow cylinder, for housing the laundry and in general the clothes and garments to be washed and/or dried. The drum 102 is preferably rotatably fixed to the casing, so that it can rotate around an axis thereof. According to the present embodiment, the rotation axis of the drum 102 is substantially horizontal but it should be appreciated that, as an alternative, the drum can be positioned in the casing 101 in such a position that its rotation axis is vertical or tilted.

**[0044]** An aperture 101a is defined in the casing, facing the treatment chamber and thus granting access to the drum for loading and unloading the laundry in the device.

The laundry treatment device 100 further comprises a door assembly 1, preferably pivotally supported on the casing 101 and displaceable between an open position, shown in Fig. 1 and in which access to the drum is granted, and a closed position, in which the aperture 101a is closed or preferably sealed.

**[0045]** According to the present embodiment, the aperture 101a is defined in a front face 103 of the casing 101, in which are also located a control panel 104 of the device 100 and a drawer 105 suitable for containing detergents and other additives in washing machines or for collecting water in dryers.

**[0046]** In other words, the device 100 according to present embodiment is a front-load device. Nevertheless it will be appreciated that the present invention could also apply to different type of laundry treatment devices, such as top-loading ones.

**[0047]** Always with reference to Fig. 1, the laundry treatment device 100 further comprises a lock assembly 2 for locking the door assembly 1 in the closed position in which the aperture 101a is closed. According to a preferred embodiment, the lock assembly 2 comprises a latch 21 suitable for engaging in a respective hole 30 provided in casing 101, advantageously in a position adjacent to the aperture 101a. Preferably, the latch 21 is hook-shaped and it is engaged in the hole 30 in a locking position of the locking device, thus avoiding the opening of the door assembly 1, and disengaged from the hole 30 in a unlocking position in which the door assembly 1 is free to rotate about the axis on which it is hinged.

**[0048]** Preferably, the door assembly 1 comprises a door frame 10 supporting the latch 21 and, more in general, the locking device 2. The locking device 2 further comprises a handle 20 which is also preferably associated to the door frame 10. Advantageously, the handle 20 is operatively connected to the latch 21 in such a way that it can be switched between the locking position and the unlocking position through rotation of the handle 20. According to alternative embodiments, not shown in the Figures, the handle 20 can be rigidly fixed to the door frame 10 or even formed by a recess defined in the door frame. In such alternative embodiments, the latch and the respective opening are shaped such that when the door is pulled sufficiently, the latch is automatically disengaged. Accordingly, the door assembly is opened without requiring any rotation of the handle or any other leverage operating the latch.

**[0049]** According to the present advantageous embodiment, the door assembly 1 further comprises a screen 15, preferably made of glass, preferably allowing visual access to the treatment chamber when the door assembly 1 is closed. The screen 15 is supported by the door frame 10.

**[0050]** According to alternative embodiments, not illustrated in the Figures, the door assembly 1 could be formed as a single piece, for example when visual access to the treatment chamber 102 is not required. In these cases, the door frame could be disk-shaped instead of

being annular shaped as in the previous embodiment.

**[0051]** It should be also noted that in the previous embodiments the door assembly 1 and the frame 10 are substantially circular, but even different shapes could be envisaged.

**[0052]** The hole 30 into which the latch 21 engages is associated to a holding device 3 of the lock assembly 2, capable of holding the lock assembly 2 in a closed position under predetermined conditions, e.g. during a laundry washing and/or drying cycle.

**[0053]** As shown in Fig. 2, the holding device 3 is mounted on a front wall 106 of the laundry treating device 100, preferably corresponding (or coinciding) to the front face 103 of the casing 101. Always according to a preferred embodiment, the holding device 3 is positioned next to a border of the aperture 101a and, preferably, in an opposite position with respect to the hinge axis H of the door assembly 101. Always preferably, the holding device 3 is fixed to the wall 106 by means of suitable fixing elements 400, such as bolts and nuts, schematically shown in Fig. 1.

**[0054]** The holding device advantageously comprises seats 36 formed on a side extension 3" of holding device 3 and capable of receiving the fixing elements 400.

**[0055]** According to a preferred embodiment, the holding device 3 comprises a shutter 31 - shown only in the embodiment of Fig. 5 - capable of holding the latch 21 in the hole 30. It will be appreciated that the shutter 31 can be displaced from a retracted position, in which it does not obstruct the hole 30 and, accordingly, passage of latch 21 through the hole 30 is permitted, to an extended position, in which the extension of hole 30 is reduced and the passage of latch 21, and in particular of an enlarged head thereof, is inhibited.

**[0056]** In this manner, when the door assembly is closed and the shutter is in the extended position, opening of the door assembly will be prevented even when the handle is rotated or strongly pulled.

**[0057]** Preferably, the shutter is electrically operated by means of a control unit 300 of the laundry treating device 100, schematically shown in Fig. 1.

**[0058]** Advantageously, the conditions under which the lock assembly 2 is hold can be stored in the control unit 300 in order to prevent opening of the door assembly 2 not only when the laundry treating device is operating but also, e.g., when water is detected inside the drum 102, or at least for a certain amount of time when a washing cycle is interrupted.

**[0059]** According to a preferred embodiment, the holding device 3 is connected to the control unit 300 by means of electric wires W. It will be appreciated that although three different wires are depicted in the Figures, a different number of wires can be used for connecting the holding device 3 to the control unit 300.

**[0060]** With reference to Figs. 3 and 4, wires W are connected to holding device 3 by means of a first connector element 4, in which ends of the wires W are fixed.

**[0061]** Preferably, the holding device 3 comprises a

second connector element 34, connectable or connectable to the first connector element 4 in order to bring an electric power and signal to holding device 3 for selectively holding the hook assembly 2 (for example for operating and controlling the shutter 31 in the embodiments illustrated in enclosed figures).

**[0062]** As shown in Fig. 3, the second connector element 34 is positioned in a main body 3' of the holding device and it is electrically connected to an electromechanical device arranged in order to be able to selectively hold the hook assembly 2; this electromechanical device can comprise, for example, an electromagnet associated to a spring or to other suitable electric operated device - not shown - operating the shutter from the retracted to the extended position and vice versa. Preferably, the electromagnet and its spring are housed in the main body 3'.

**[0063]** According to a preferred embodiment, the first and second connector elements comprise a plug 4 and a respective socket 34. Preferably, the socket is defined in the holding device 3, but alternatively, the first connector element could be in form of a socket and the respective plug can be fixed to the holding device 3. A plugging direction P is defined (identified by arrows in Figs. 4 and 6 and by an axis in the other Figures) by the direction along which the plug 4 is pushed when inserted in the socket 34.

**[0064]** The laundry treating machine according to the present invention further comprises a cover member 5, at least partially covering the first connector element 4 and/or the holding device 3.

**[0065]** Preferably, the cover member 5, best shown in Figs. 3 and 4, comprises a casing 5', enclosing the first connector element 4 and partially the holding device 3. Preferably, but not necessarily, the casing 5' is at least partially made of transparent material, thus advantageously allowing visual control of the first connector element 4 and of the holding device 3 even after the cover member is positioned thereon.

**[0066]** According to a preferred embodiment, inside the casing 5' at least one rib 51 is defined. Preferably, the rib 51 develops parallel to the plugging direction P. Always according to a preferred embodiment, the rib 51 projects from a cover surface 54 of the cover member 5 in such a way that when the cover member 5 is fixed to the holding device 3, the rib 51 is substantially parallel to the front wall 106.

**[0067]** An abutment surface 50 is defined at an end of the rib 51, abutting on the first connector element 4 when the wires W are properly connected to the holding device 3.

**[0068]** In the present embodiment, the abutments surface 50 abuts against a surface of the plug 4 oriented substantially perpendicularly to the plugging direction P.

**[0069]** Advantageously, the first connector element 4 is positioned, in use, between the abutment surface 50 and the second connector element 34.

**[0070]** It will be therefore appreciated that the abut-

ment surface 50 abuts on a respective surface 40 of the first connector element 4 when connected to the second connector element 34. In this manner movements of the first connector element 4 along a direction opposed to said plugging direction P with respect to the second connector element 34 (in other words separations of the first connector element 4 from the second connector element 34) are prevented. It should be noted that it is not required for the present invention that the abutment surface 50 contacts the respective surface 40 of the first connector element 4 when completely inserted into the second connector element 34. In fact, a proper electric connection could be also provided when the first connector element is partially withdrawn from the second connector element 34 and it will be sufficient that the abutment surface 50 enters into contact with the respective surface of the first connector element 4 before the electric connection is impaired.

**[0071]** As schematically shown in Fig. 2, the cover member 5 advantageously comprises a fastening device for fixing the cover member 5 to the holding device 3. It will be appreciated that the cover member 5 can be directly fixed to the holding device 3 as in the present embodiment, or it can be fixed thereto through a connection to the front wall or to any other part to which the holding device is also fixed. Furthermore, the cover member 5 is preferably removably fixed to the holding device.

**[0072]** Accordingly, the presence of the cover member 5 allows keeping the first connector element 4 in a proper connected position since withdrawal thereof from the holding device 3 is prevented by the abutment surface 50 as long as the cover member 5 is fixed to the holding device 3. Also a proper connection of the first connector element 4 can be verified by the cover member 5, which can be correctly positioned only if the first connector element 4 is connected to the holding device 3.

**[0073]** As shown schematically in Fig. 2, according to a preferred embodiment, the fastening device comprises a projection 32, preferably wedge-shaped, and a receiving opening 52 for the projection 32, formed on the holding device 3 and on the cover member 5, respectively, or vice-versa.

**[0074]** Preferably, the projection 32 is provided on a top surface 35 of the main body 3' of the holding device 3, facing the cover surface 54 of the cover member 5. Advantageously, the projection 32 is slanted towards a direction opposed to the plugging direction P. Always according to a preferred embodiment, the receiving opening 52 is formed on a flexible flap 53 of the cover member.

**[0075]** With reference to Fig. 4, preferably the fastening device comprises a second projection 32a, also preferably wedge-shaped, provided on a side surface of the main body 3' of the holding device 3, and a respective second receiving opening 52a for the projection 32a, provided on a side surface of the cover member 5.

**[0076]** Preferably, a depression 53a is defined in the cover member 5 next to the opening 52a, allowing an increased flexibility of the cover member in a portion of

the cover member to be locally deformed for the projection 32a to engage the opening 52a.

**[0077]** Advantageously, this structure allows fastening the cover member 5 to the holding device 3 by moving the former along the plugging direction P.

**[0078]** In this manner, when the cover member 5 is fastened, the abutment surface 50 will push the first connector element 4 inside the second connector element 34 thus guaranteeing a proper connection of the wires W.

**[0079]** To this regard, it should be noted that when the cover member 5 is moved towards the holding device 3 for the purpose of fixing it thereto, if the first connector element 4 is not correctly positioned, the abutment surface 50 urges against the first connector element 4. This will result in an interaction between the abutment surface 50 and the first connector element 4.

**[0080]** The effect of this interaction differs depending on the position of the first connector element 4. In fact, the first connector element 4, although not properly or completely plugged, can be positioned aligned with the plugging direction P (e.g. when it is only partially plugged) and, in this case, the abutment surface 50 urges the first connector element 4 in a correct connected position as a consequence of the movement of the cover member 5 towards a fixing position (i.e. the one required for fixing it to the holding device).

**[0081]** Alternatively, if the first connector element 4 is not aligned with its plugging direction P (e.g. because, in case of the plug-and-socket connection, the plug is rotated with respect to the socket) or, in general, if the first connector element cannot be plugged (e.g. because a pin of the connector is bent) then the contact between the abutment surface 50 and the respective surface 40 of the first connector element 4 (which in this case can't move in the plugging direction P) prevents the assembly of the cover member 5, thus allowing an immediate acknowledgment of the improper connection.

**[0082]** Although in the present embodiment the fixing movement of the cover member 5 is aligned to the plugging direction P of the first connector element 4, the above described interaction of the cover member 5 with the first connector element 4 can be also advantageously obtained by any movement of the cover member 5 determining a movement of the abutment surface 50 having at least a component of motion oriented along the plugging direction P.

**[0083]** For example, according to alternative embodiments not shown in the Figures, the cover member can be positioned in the fixing position by rotating it. Such movement generates a corresponding rotation of the abutment surface. Since the abutment surface is advantageously positioned such that the rotation determines a movement of the abutment surface having at least a component of motion oriented along the plugging direction, also in this case either a correct connection of the first connector element can be obtained or the improper connection can be acknowledged.

**[0084]** It should be noted that also different movements

required for fixing the cover surface to the holding device can be envisaged. For example, according to a further embodiment, also not shown in the Figures, if the abutment surface is tilted to the respective surface of the first connector element, the fixing movement of the cover member can be tilted to the plugging direction, since the first connector element can be pushed in the connected position by means of the abutment surface sliding thereon.

**[0085]** According to a preferred embodiment, the cover member 5 comprises wire clips 56, preferably formed by two flexible hook-shaped elements. The wire clips 56 are capable of holding the wires W. In this manner wires W can be placed on the cover member 5 before fastening it to the holding device 3, thus assuring a correct positioning of the wires.

**[0086]** Preferably, the clips 56 are formed on an extension 5" of the casing 5'. An opening 55 is also defined on said casing 5' for allowing the passage of the wires W towards the extension 5". Preferably, opening 55 faces away from plugging direction P. In this manner the risk of pinching the wires W between the first connector element 4 and the abutments surface is minimized.

**[0087]** Also, as shown in Fig. 3, because of the presence of the opening 55 facing away from the plugging direction P, advantageously the wires W exit the casing 5' developing according a curved line. Such development of the wires W defines a bend advantageously positioned below the connector element.

**[0088]** As a consequence, if a drop of water (e.g. caused by condensation or by minimal spillages of water for the hydraulic system of the laundry treatment device) wets one of the wires W, it will run on the wire for the action of gravity stopping at said bend without reaching the connector element 4.

**[0089]** Preferably, the casing 5' of the cover member is separated from the extension 5" by a dividing wall 57, thus creating a barrier against drops of water falling from the wires W above the connector element 4.

**[0090]** According to a preferred embodiment, the cover member 5 comprises at least two ribs 51, 51', 51", each provided with a respective abutment surface 50, 50', 50" separated therebetween. The abutment surfaces 50, 50', 50" can be separated both along a direction parallel to the plugging directing and along a direction perpendicular thereto.

**[0091]** The presence of more than one ribs - three in the present embodiment - advantageously allows to use the same cover member 5 with different connector elements.

**[0092]** As shown in the embodiment of Figs. 5 and 6, the abutment surface 50" can abut on the surface of the connector element 4 when used in a holding element having a different shape from the one of the previous embodiment.

**[0093]** The embodiment of Figs. 5 and 6 differs from the previous embodiment in that it comprises a first and second fastening devices formed on opposite surfaces

54, 54' of the cover member 5.

**[0094]** Preferably, the second fastening device also comprises a projection 32' and a receiving opening 52' provided on a top surface 35' of the main body 3' of the holding device 3, and on a cover surface 54' of the cover member 5. Preferably, the receiving opening 52' is formed on a flexible flap 53' of the cover member 5.

**[0095]** It has thus been shown that the present invention allows all the set objects to be achieved. In particular, any risk of improper connection of the holding device is avoided since the cover member cannot be correctly fastened in case the connector element is not completely and correctly inserted.

**Claims**

1. A laundry treatment device (100) comprising:

- a casing (101) enclosing a treatment chamber (102) for receiving a load to be treated, said casing comprising an aperture (101a) allowing access to said treatment chamber (102);
- a door assembly (1) mounted on said casing (101) for opening and closing said aperture (101a);
- a lock assembly (2) of said door assembly (1);
- a holding device (3) of said lock assembly (2) capable of holding said lock assembly (2) in a closed position under predetermined conditions, said holding device (3) being connected or connectable, by means of electric wires (W), to a control unit (300);
- a first connector element (4) for electrically connecting said wires (W) to said holding device (3);
- a cover member (5) at least partially covering said first connector element (4) and/or said holding device (3);

**characterized in that** said cover member (5) comprises an abutment surface (50) abutting on said first connector element (4) when said wires (W) are electrically connected to said holding device (3).

2. The laundry treatment device (1) according to claim 1, wherein said holding device (3) comprises a second connector element (34) connected or connectable to said first connector element (4), said first connector element (4) being positioned, in use, between said abutment surface (50) and said second connector element (34).

3. The laundry treatment device (1) according to claim 2, wherein said first and second connector elements comprise a plug (4) and a respective socket (34), said first and second connector elements being connectable by inserting said plug (4) in said socket (34) along a plugging direction (P).

4. The laundry treatment device (1) according to claim 3, wherein said abutment surface (50) abuts on a respective surface of said first connector (4) when connected to said second connector (34), so that movement of said first connector (4) along a direction opposed to said plugging direction (P) are prevented.

5. The laundry treatment device (1) according to any of the preceding claims, wherein said abutment surface (50) is formed on a respective rib (51) projecting from a cover surface (54) of said cover member (5).

6. The laundry treatment device (1) according to claim 5, wherein said cover member (5) comprises a casing (5') at least partially enclosing said holding device (3), said rib (51) being formed inside said casing (5').

7. The laundry treatment device (1) according to claim 6, wherein an opening (55) is provided in said casing (5'), said opening (55) facing away from said plugging direction (P) and allowing the passage of at least one of said wires (W).

8. The laundry treatment device (1) according to claim 6 or 7, wherein said cover member (5) further comprises an extension (5'') through which said wires (W) passes, said casing (5') being separated from said extension (5'') by a dividing wall (57).

9. The laundry treatment device (1) according to any of the preceding claims, wherein said cover member (5) comprises a fastening device (52, 32, 52', 32') for removably fixing said cover member (5) to said holding device (3).

10. The laundry treatment device (1) according to claim 9, wherein said cover member (5) is fastened to said holding device (3) by moving said cover member (5) towards said holding device (3) along said plugging direction (P).

11. The laundry treatment device (1) according to claim 9 or 10, wherein said fastening device (52, 32, 52', 32') comprises a projection (32, 32') and a receiving opening (52, 52') for said projection (32, 32'), formed one on said holding device (3) and the other on said cover member (5).

12. The laundry treatment device (1) according to claim 11, wherein said projection (32; 32') is slanted towards a direction opposed to said plugging direction (P), said receiving opening (52; 52') being formed on a flexible flap (53, 53') of said holding device (3).

13. The laundry treatment device (1) according to any of claims 9 to 12, comprising first and second fastening devices (52, 32; 52', 32'), said first and second fastening devices (52, 32; 52', 32') being formed on

opposite surfaces (54; 54') of said cover member (5).

14. The laundry treatment device (1) according to any of the preceding claims, wherein said cover member (5) comprises at least two abutment surfaces (50, 50', 50'') separated therebetween. 5
15. The laundry treatment device (1) according to any of the preceding claims, wherein said cover member (5) comprises wire clips (56) capable of holding at least one of said wires (W). 10

### Patentansprüche

1. Wäschebehandlungsvorrichtung (100), umfassend: 15

- ein Gehäuse (101), das eine Behandlungskammer (102) für die Aufnahme einer zu behandelnden Ladung umschließt, wobei das Gehäuse eine Apertur (101 a) umfasst, die den Zugang zu der Behandlungskammer (102) ermöglicht; 20
- eine Türanordnung (1), die an dem Gehäuse (101) befestigt ist, zum Öffnen und Schließen der Apertur (101 a); 25
- eine Verschlussanordnung (2) der Türanordnung (1);
- eine Haltevorrichtung (3) der Verschlussanordnung (2), welche die Verschlussanordnung (2) unter vorgegebenen Bedingungen in einer geschlossenen Position halten kann, wobei die Haltevorrichtung (3) über elektrische Drähte (W) mit einer Steuereinheit (300) verbunden ist oder verbunden werden kann; 30
- ein erstes Verbindungselement (4) zum elektrischen Verbinden der Drähte (W) mit der Haltevorrichtung (3); 35
- ein Abdeckelement (5), das zumindest teilweise das erste Verbindungselement (4) und/oder die Haltevorrichtung (3) abdeckt; 40

**dadurch gekennzeichnet, dass** das Abdeckelement (5) eine Anlagefläche (50) umfasst, die an dem ersten Verbindungselement (4) anliegt, wenn die Drähte (W) elektrisch mit der Haltevorrichtung (3) verbunden sind. 45

2. Wäschebehandlungsvorrichtung (1) nach Anspruch 1, wobei die Haltevorrichtung (3) ein zweites Verbindungselement (34) umfasst, das mit dem ersten Verbindungselement (4) verbunden ist oder verbunden werden kann, wobei das erste Verbindungselement (4) bei der Verwendung zwischen der Anlagefläche (50) und dem zweiten Verbindungselement (34) positioniert ist. 50
3. Wäschebehandlungsvorrichtung (1) nach Anspruch 2, wobei die ersten und zweiten Verbindungsele-

mente einen Stecker (4) und eine entsprechende Aufnahme (34) umfassen, wobei die ersten und zweiten Verbindungselemente durch das Einführen des Steckers (4) in die Aufnahme (34) entlang einer Steckrichtung (P) verbunden werden können.

4. Wäschebehandlungsvorrichtung (1) nach Anspruch 3, wobei die Anlagefläche (50) an einer entsprechenden Fläche des ersten Verbindungselements (4) anliegt, wenn es mit dem zweiten Verbindungselement (34) verbunden ist, sodass eine Bewegung des ersten Verbindungselements (4) entlang einer der Steckrichtung (P) entgegengesetzten Richtung verhindert wird.

5. Wäschebehandlungsvorrichtung (1) nach einem der vorhergehenden Ansprüche, wobei die Anlagefläche (50) auf einer entsprechenden Rippe (51) geformt wird, die von einer Abdeckfläche (54) des Abdeckelements (5) hervorsteht.

6. Wäschebehandlungsvorrichtung (1) nach Anspruch 5, wobei das Abdeckelement (5) ein Gehäuse (5') umfasst, das zumindest teilweise die Haltevorrichtung (3) umschließt, wobei die Rippe (51) in dem Gehäuse (5') geformt wird.

7. Wäschebehandlungsvorrichtung (1) nach Anspruch 6, wobei in dem Gehäuse (5') eine Öffnung (55) bereitgestellt wird, wobei die Öffnung (55) von der Steckrichtung (P) abgewendet ist und den Durchgang von mindestens einem der Drähte (W) ermöglicht.

8. Wäschebehandlungsvorrichtung (1) nach Anspruch 6 oder 7, wobei das Abdeckelement (5) ferner eine Erweiterung (5'') umfasst, durch welche die Drähte (W) hindurchgehen, wobei das Gehäuse (5') von der Erweiterung (5'') durch eine Trennwand (57) getrennt ist. 40

9. Wäschebehandlungsvorrichtung (1) nach einem der vorhergehenden Ansprüche, wobei das Abdeckelement (5) eine Befestigungsvorrichtung (52, 32, 52', 32') zum lösbaren Befestigen des Abdeckelements (5) an der Haltevorrichtung (3) umfasst.

10. Wäschebehandlungsvorrichtung (1) nach Anspruch 9, wobei das Abdeckelement (5) an der Haltevorrichtung (3) durch die Bewegung des Abdeckelements (5) in Richtung der Haltevorrichtung (3) entlang der Steckrichtung (P) befestigt wird.

11. Wäschebehandlungsvorrichtung (1) nach Anspruch 9 oder 10, wobei die Befestigungsvorrichtung (52, 32, 52', 32') einen Vorsprung (32, 32') und eine Aufnahmeöffnung (52, 52') für den Vorsprung (32, 32') umfasst, wobei eines an der Haltevorrichtung (3) und

das andere an dem Abdeckelement (5) geformt ist.

12. Wäschebehandlungsvorrichtung (1) nach Anspruch 11, wobei der Vorsprung (32, 32') in einer Richtung geneigt ist, die der Steckrichtung (P) entgegengesetzt ist, wobei die Aufnahmeöffnung (52, 52') an einer flexiblen Klappe (53, 53') der Haltevorrichtung (3) geformt ist.
13. Wäschebehandlungsvorrichtung (1) nach einem der Ansprüche 9 bis 12, umfassend erste und zweite Befestigungsvorrichtungen (52, 32, 52', 32'), wobei die ersten und zweiten Befestigungsvorrichtungen (52, 32, 52', 32') an gegenüberliegenden Flächen (54; 54') des Abdeckelements (5) geformt sind.
14. Wäschebehandlungsvorrichtung (1) nach einem der vorhergehenden Ansprüche, wobei das Abdeckelement (5) mindestens zwei dazwischen getrennte Anlageflächen (50, 50', 50'') umfasst.
15. Wäschebehandlungsvorrichtung (1) nach einem der vorhergehenden Ansprüche, wobei das Abdeckelement (5) Drahtklemmen (56) umfasst, die zumindest einen der Drähte (W) halten können.

#### Revendications

1. Dispositif de traitement du linge (100) comprenant :
- un carter (101) entourant une chambre de traitement (102) destinée à recevoir une charge à traiter, ledit carter comprenant une ouverture (101a) permettant d'accéder à ladite chambre de traitement (102) ;
  - un ensemble de porte (1) monté sur ledit carter (101) pour ouvrir et fermer ladite ouverture (101a) ;
  - un ensemble de verrou (2) dudit ensemble de porte (1) ;
  - un dispositif de maintien (3) dudit ensemble de verrou (2), capable de maintenir ledit ensemble de verrou (2) dans une position fermée sous des conditions prédéterminées, ledit dispositif de maintien (3) étant raccordé ou apte à être raccordé à une unité de commande (300) à l'aide de fils électriques (W) ;
  - un premier élément de connexion (4) destiné à raccorder électriquement lesdits fils (W) audit dispositif de maintien (3) ;
  - un élément de couverture (5) recouvrant au moins partiellement ledit premier élément de raccordement (4) et/ou ledit dispositif de maintien (3) ;

**caractérisé en ce que** ledit élément de couverture (5) comprend une surface de butée (50) butant con-

tre ledit premier élément de raccordement (4) lorsque lesdits fils (W) sont électriquement reliés audit dispositif de maintien (3).

2. Dispositif de traitement du linge (1) selon la revendication 1, dans lequel ledit dispositif de maintien (3) comprend un deuxième élément de raccordement (34) raccordé ou apte à être raccordé audit premier élément de raccordement (4), ledit premier élément de raccordement (4) étant positionné entre ladite surface de butée (50) et ledit deuxième élément de raccordement (34) pendant l'utilisation.
3. Dispositif de traitement du linge (1) selon la revendication 2, dans lequel lesdits premier et deuxième éléments de raccordement comprennent une fiche (4) et une prise (34) respective, lesdits premier et deuxième éléments de raccordement pouvant être raccordés en insérant ladite fiche (4) dans ladite prise (34) le long d'une direction d'enchâssement (P).
4. Dispositif de traitement du linge (1) selon la revendication 3, dans lequel ladite surface de butée (50) bute contre une surface respective dudit premier élément de raccordement (4) lorsqu'il est raccordé audit deuxième élément de raccordement (34), de manière à empêcher le mouvement dudit premier élément de raccordement (4) le long d'une direction opposée à ladite direction d'enchâssement (P).
5. Dispositif de traitement du linge (1) selon l'une quelconque des revendications précédentes, dans lequel ladite surface de butée (50) est formée sur une nervure (51) respective faisant saillie à partir d'une surface de couverture (54) dudit élément de couverture (5).
6. Dispositif de traitement du linge (1) selon la revendication 5, dans lequel ledit élément de couverture (5) comprend un carter (5') entourant au moins partiellement ledit dispositif de maintien (3), ladite nervure (51) étant formée à l'intérieur dudit carter (5').
7. Dispositif de traitement du linge (1) selon la revendication 6, dans lequel une ouverture (55) est prévue dans ledit carter (5'), ladite ouverture (55) étant détournée de ladite direction d'enchâssement (P) et permettant le passage d'au moins l'un desdits fils (W).
8. Dispositif de traitement du linge (1) selon la revendication 6 ou 7, dans lequel ledit élément de couverture (5) comprend en outre une extension (5'') à travers laquelle passent lesdits fils (W), ledit carter (5') étant séparé de ladite extension (5'') par une paroi de division (57).
9. Dispositif de traitement du linge (1) selon l'une quelconque des revendications précédentes, dans le-

quel ledit élément de couverture (5) comprend un dispositif de fixation (52, 32, 52', 32') destiné à fixer de façon amovible ledit élément de couverture (5) audit dispositif de maintien (3).

5

- 10.** Dispositif de traitement du linge (1) selon la revendication 9, dans lequel ledit élément de couverture (5) est fixé audit dispositif de maintien (3) en déplaçant ledit élément de couverture (5) vers ledit dispositif de maintien (3) le long de ladite direction d'enfichage (P). 10
- 11.** Dispositif de traitement du linge (1) selon la revendication 9 ou 10, dans lequel ledit dispositif de fixation (52, 32, 52', 32') comprend une saillie (32, 32') et une ouverture de réception (52, 52') pour ladite saillie (32, 32'), formées l'une sur ledit dispositif de maintien (3) et l'autre sur ledit élément de couverture (5). 15
- 12.** Dispositif de traitement du linge (1) selon la revendication 11, dans lequel ladite saillie (32, 32') penche dans une direction opposée à ladite direction d'enfichage (P), ladite ouverture de réception (52 ; 52') étant formée sur un rabat souple (53, 53') dudit dispositif de maintien (3). 20
- 13.** Dispositif de traitement du linge (1) selon l'une quelconque des revendications 9 à 12, comprenant des premier et deuxième dispositifs de fixation (52, 32, 52', 32'), lesdits premier et deuxième dispositifs de fixation (52, 32, 52', 32') étant formés sur des surfaces opposées (54 ; 54') dudit élément de couverture (5). 25
- 14.** Dispositif de traitement du linge (1) selon l'une quelconque des revendications précédentes, dans lequel ledit élément de couverture (5) comprend au moins deux surfaces de butée (50, 50', 50'') séparées entre elles. 30
- 15.** Dispositif de traitement du linge (1) l'une quelconque des revendications précédentes, dans lequel ledit élément de couverture (5) comprend des attaches (56) capables de maintenir au moins l'un desdits fils (W). 35

40

45

50

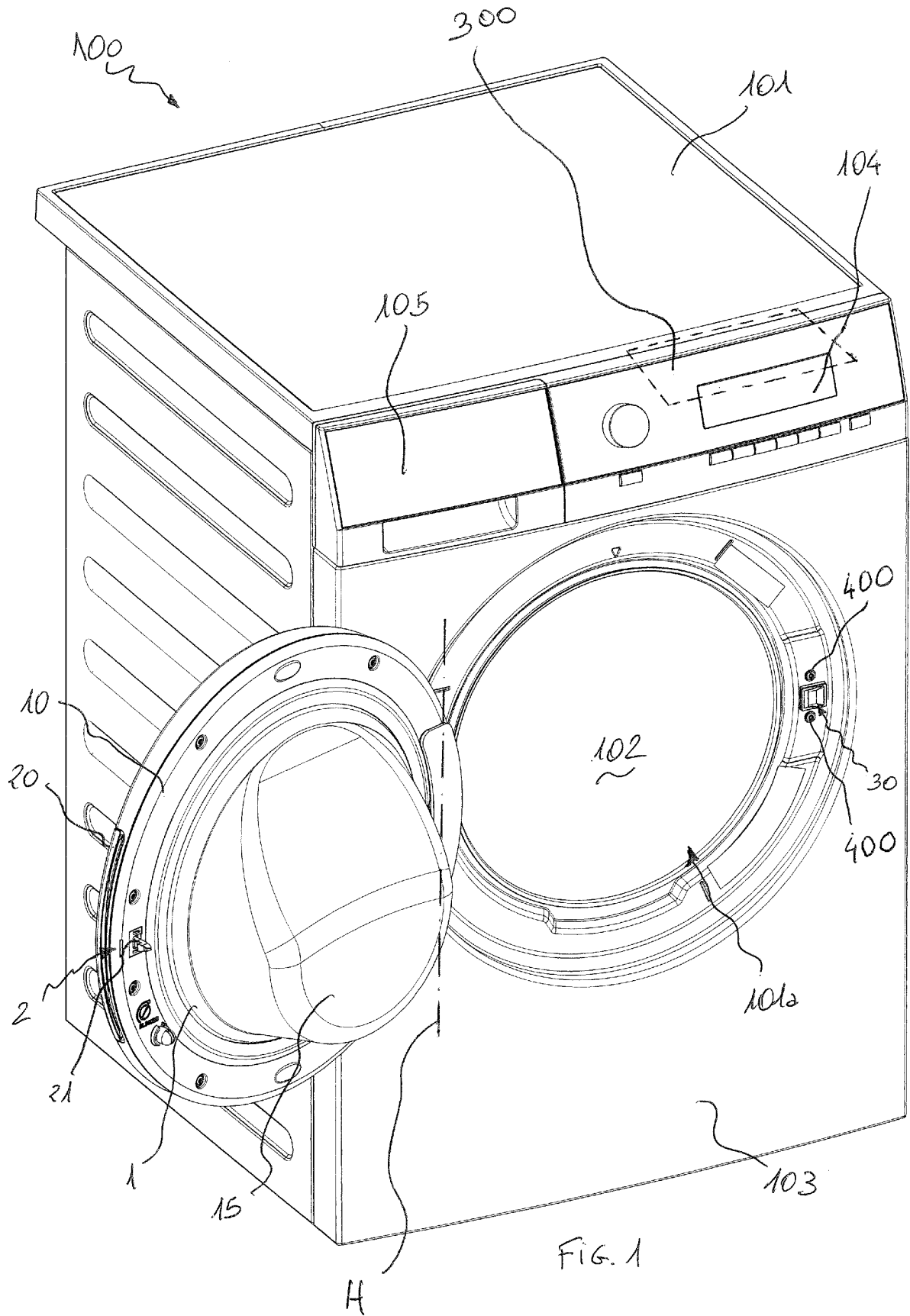

FIG. 1

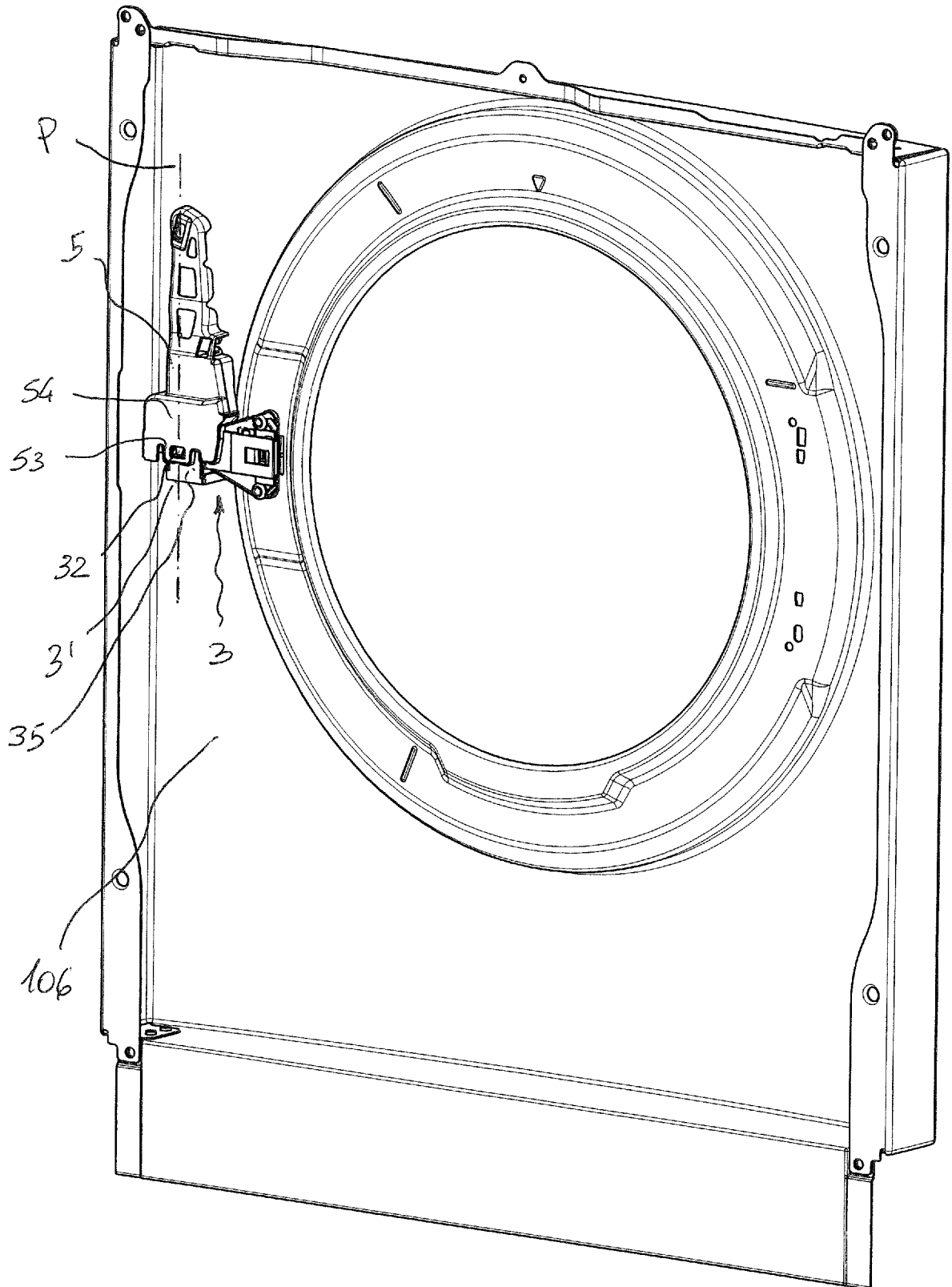

FIG. 2

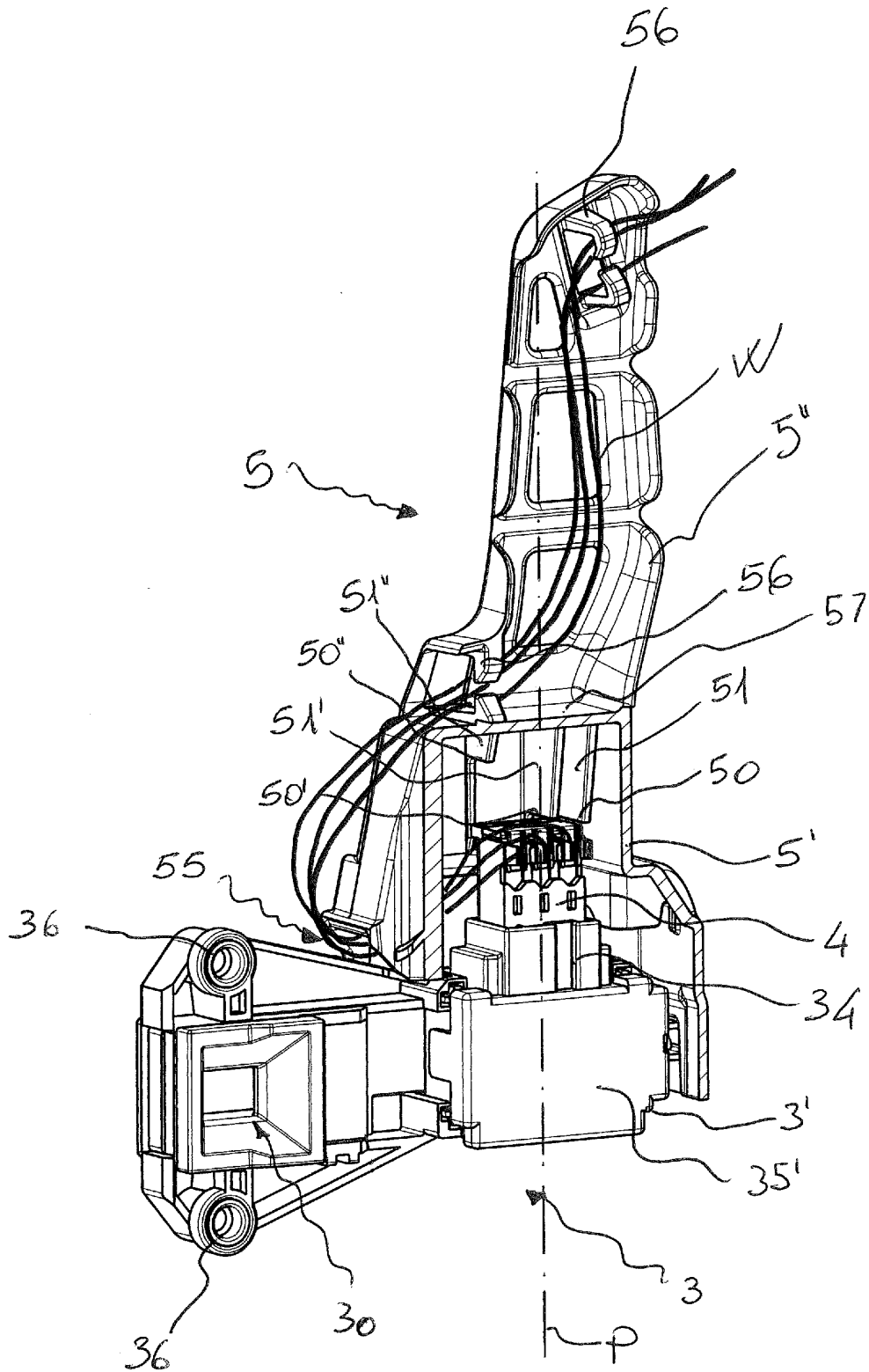

FIG. 3

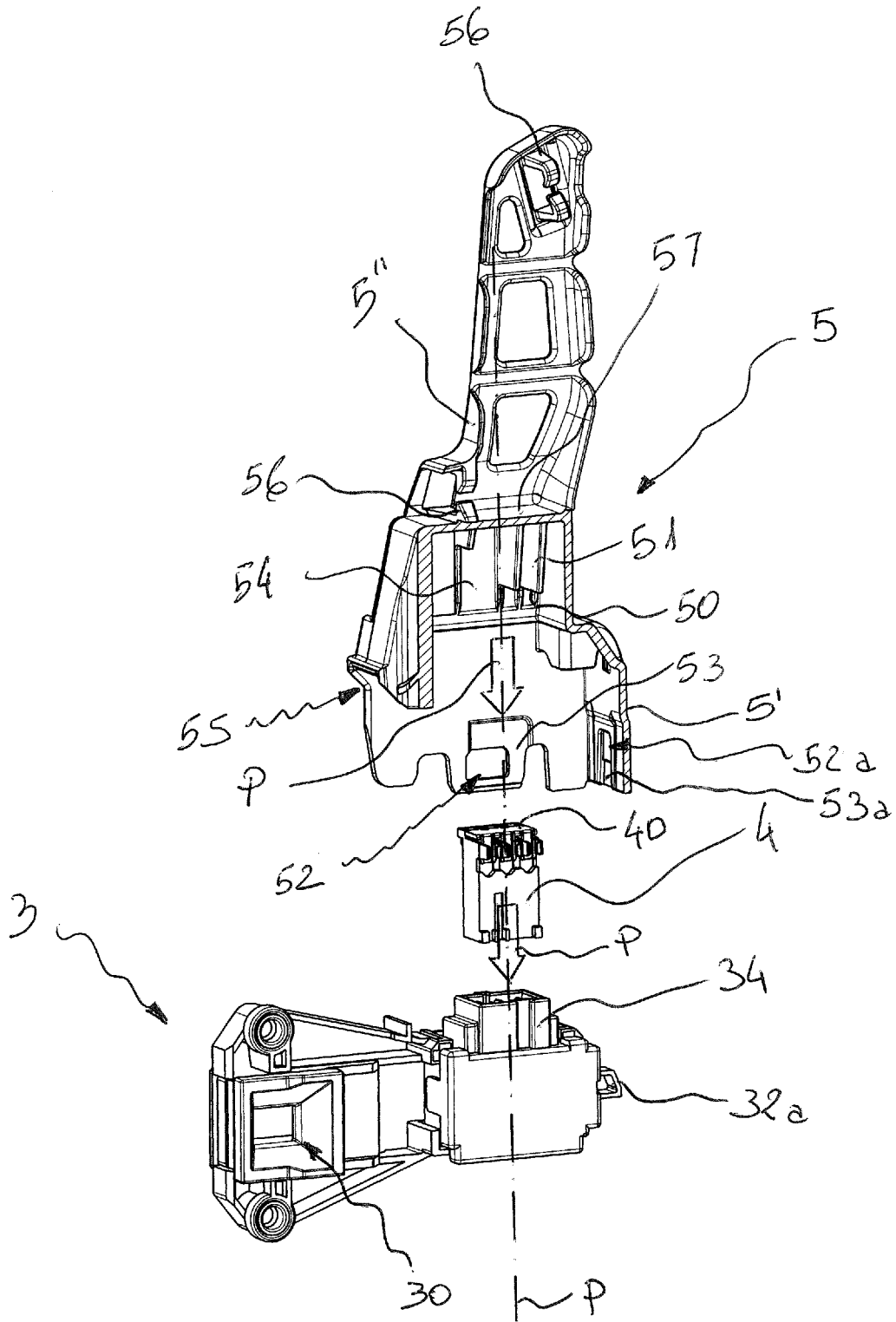

FIG 4

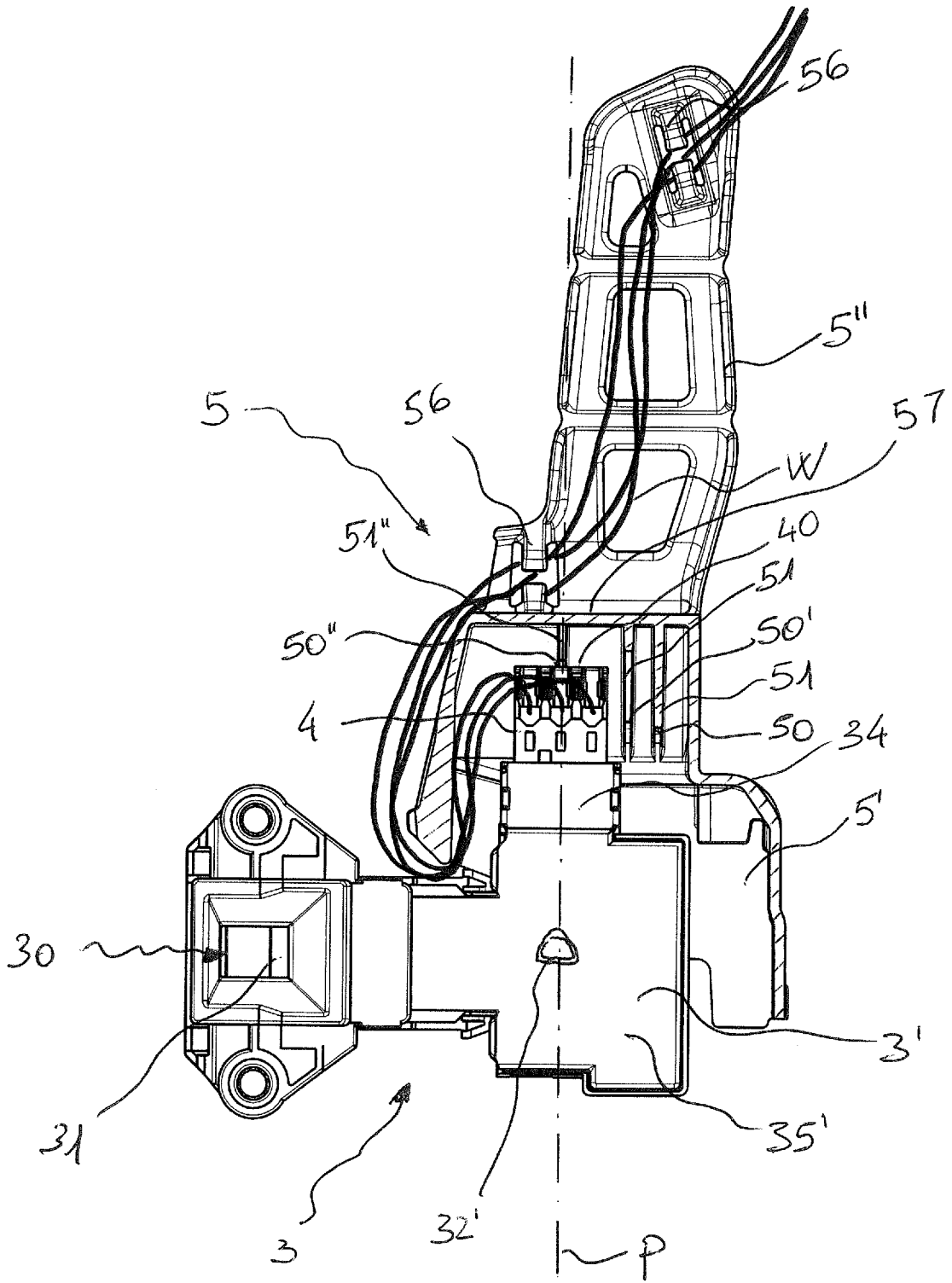

FIG. 5

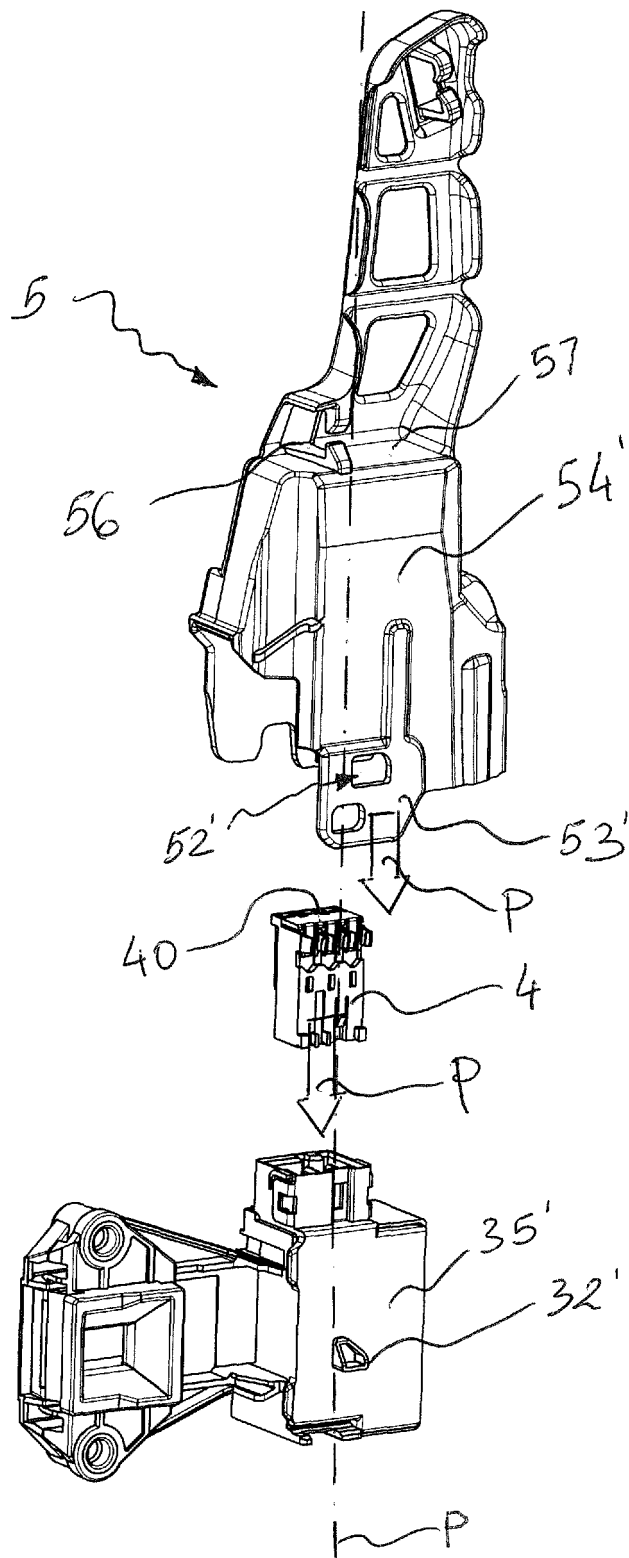

FIG. 6

**REFERENCES CITED IN THE DESCRIPTION**

*This list of references cited by the applicant is for the reader's convenience only. It does not form part of the European patent document. Even though great care has been taken in compiling the references, errors or omissions cannot be excluded and the EPO disclaims all liability in this regard.*

**Patent documents cited in the description**

- EP 1463856 A [0007]
- WO 03004754 A [0008]