

(19) World Intellectual Property Organization
International Bureau



(43) International Publication Date
13 June 2002 (13.06.2002)

PCT

(10) International Publication Number
WO 02/47307 A1

- (51) International Patent Classification⁷: H04J 14/02 (US). SHANTON, John, Lynn, III; 6263 Harley Road, Middletown, MD 21769 (US). YU, Wenli; 444 N. Frederick Avenue, #E350, Gaithersburg, MD 20877 (US).
- (21) International Application Number: PCT/US01/45752
- (22) International Filing Date: 7 December 2001 (07.12.2001)
- (25) Filing Language: English
- (26) Publication Language: English
- (30) Priority Data: 09/731,760 8 December 2000 (08.12.2000) US
- (71) Applicant: SENECA NETWORKS, INC. [US/US]; 30 West Gude Drive, Suite 200, Rockville, MD 20850 (US).
- (72) Inventors: JIANG, Leon, Li-Feng; 14 Brian's Way, Princeton Junction, NJ 08550 (US). MONTALVO, Raul, B.; 11413 Guerlac Court, North Potomac, MD 20878
- (74) Agents: GOTTS, Lawrence, J. et al.; Shaw Pittman LLP, 1650 Tysons Boulevard, McLean, VA 22102-4859 (US).
- (81) Designated States (national): AE, AG, AL, AM, AT, AU, AZ, BA, BB, BG, BR, BY, BZ, CA, CH, CN, CO, CR, CU, CZ, DE, DK, DM, DZ, EE, ES, FI, GB, GD, GE, GH, GM, HR, HU, ID, IL, IN, IS, JP, KE, KG, KP, KR, KZ, LC, LK, LR, LS, LT, LU, LV, MA, MD, MG, MK, MN, MW, MX, MZ, NO, NZ, OM, PH, PL, PT, RO, RU, SD, SE, SG, SI, SK, SL, TJ, TM, TR, TT, TZ, UA, UG, UZ, VN, YU, ZA, ZM, ZW.
- (84) Designated States (regional): ARIPO patent (GH, GM, KE, LS, MW, MZ, SD, SL, SZ, TZ, UG, ZM, ZW), Eurasian patent (AM, AZ, BY, KG, KZ, MD, RU, TJ, TM), European patent (AT, BE, CH, CY, DE, DK, ES, FI, FR,

[Continued on next page]

(54) Title: WDM OPTICAL COMMUNICATION NETWORK WITH DATA BRIDGING PLURAL OPTICAL CHANNELS BETWEEN OPTICAL WAVEGUIDES

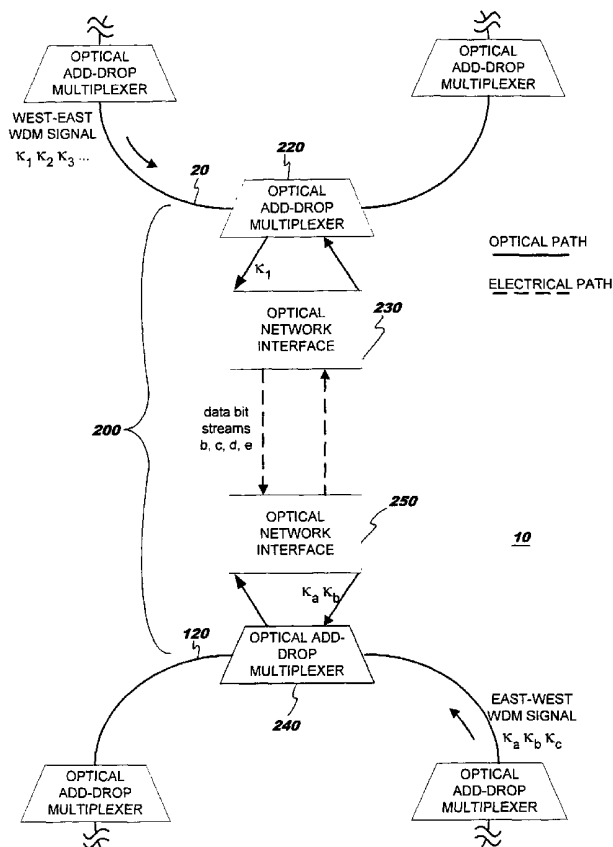

(57) Abstract: The present invention relates to an optical network including a bridge (200) for selectively transferring information from an optical channel carried on a first WDM optical waveguide (20) to at least two optical channels on a second WDM optical waveguide (120). The first and second optical waveguides carry WDM optical signals each having plural waveguides which includes an optical add-drop multiplexer (320, 320', 340, 340') optically communicating with each waveguide. At least one optical channel having first and second data bits streams is dropped from the first waveguide. The first and second data bit streams are respectively encoded on two different optical channels which are then added to the second optical waveguide.

WO 02/47307 A1



GB, GR, IE, IT, LU, MC, NL, PT, SE, TR), OAPI patent (BF, BJ, CF, CG, CI, CM, GA, GN, GQ, GW, ML, MR, NE, SN, TD, TG).

— *before the expiration of the time limit for amending the claims and to be republished in the event of receipt of amendments*

Published:

— *with international search report*

For two-letter codes and other abbreviations, refer to the "Guidance Notes on Codes and Abbreviations" appearing at the beginning of each regular issue of the PCT Gazette.

WDM OPTICAL COMMUNICATION NETWORK WITH DATA BRIDGING PLURAL OPTICAL CHANNELS BETWEEN OPTICAL WAVEGUIDES

BACKGROUND OF THE INVENTION

5 1. Field of the Invention:

The invention is directed to optical communication systems in general and, more particularly, to optical networks that include two or more waveguides each transporting a WDM optical signal composed of plural optical channels and having a data bridge for directing selected bit streams encoded on one optical channel from one waveguide to plural channels carried in a WDM optical signal on another waveguide.

10 2. Description of the Related Art

As the need for communication signal bandwidth increases, wavelength division multiplexing (WDM) has progressively gained popularity for multiplying the transmission capacity of a single optical fiber. A review of optical networks, including WDM networks, can be found in Ramaswami et al., Optical Networks: A Practical Perspective (Morgan Kaufman, © 1998), the disclosure of which is incorporated herein by reference. Typically, wavelength division multiplexed optical communication systems have been designed and deployed in the long-haul, interexchange carrier realm. In these long-haul optical systems, a wavelength division multiplexed optical communication signal comprising plural optical channels at different wavelengths travels in a single direction on a single fiber. Because the communication traffic in such systems commonly travels many hundreds of kilometers, the need for add-drop multiplexing of individual channels is infrequent (if at all), occurring at widely-spaced add-drop nodes.

25 Although the optical infrastructure of long-haul WDM optical systems can accommodate future traffic needs created by increased demand from traditional and multimedia Internet services, this traffic must first be collected and distributed by local networks. Currently, such local networks are predominantly structured to carry a single wavelength, time-division multiplexed (TDM) optical signal along a fiber network organized into various ring structures. To route the various components of the TDM signal, numerous electronic add-drop multiplexers are positioned along the fiber network. At each add-drop location, the entire optical signal is converted into an

electrical signal; the portions of the electrical signal which are destined for that add-drop point are routed accordingly. The remaining portions of the electrical signal are converted back to a new TDM optical signal and are output through the electronic add-drop multiplexer. Thus, before a user can access the bandwidth-rich WDM long-haul transport networks, he must first pass through the bottleneck of the local networks.

Although WDM optical systems are suitable for conventional long-haul interexchange carrier markets, metropolitan (local) communications systems require extensive routing and switching of traffic among various nodes positioned within interconnecting optical fiber rings. Consequently, smaller metropolitan markets require considerably more extensive add-drop multiplexing in order to successfully implement wavelength division multiplexing in their short-range systems. In addition to the difficulties posed by frequent add-drop multiplexing channels it would be desirable to direct channels from one DM optical waveguide to another. For example, in a local metropolitan network, it would be desirable to transfer traffic among adjacent rings. Further, it would be desirable to route different portions of a single optical channel carried by one waveguide to plural channels carried on another waveguide. Such a device would permit effective implementation of wavelength division multiplexing in local, metropolitan markets requiring high volumes of signal re-routing and allow creation of flexible network topologies.

SUMMARY OF THE INVENTION

The present invention relates to an optical network including a bridge for selectively transferring information from an optical channel which forms part of a first WDM optical signal carried on a first waveguide to at least two optical channels which forms part of a second WDM signal carried on a second optical waveguide. A bridge is interposed between the first and second optical waveguides. The bridge includes a first optical add-drop multiplexer optically communicating with the first waveguide which selects at least one optical channel from the first WDM signal. The first optical channel carries a first series of data bits and a second series of data bits encoded on the optical channel.

The bridge also includes a first optical network interface which includes an optical to electrical conversion element for converting the selected first optical channel to at least two electrical signals which respectively include the first and second series of

data bits. The plural electrical signals may be directly created from the optical signal or they may be derived from an electrical signal which includes both the first and second series of data bits which is subsequently separated into plural electrical signals.

The electrical signals respectively encoded with the first and second series of data bits electrically communicate with a second optical network interface. The second optical network interface includes at least two electrical to optical conversion elements such that the second electrical signal encoded with the first series of data bits is used to modulate a second optical channel and the third electrical signal encoded with the second series of data bits is used to modulate a third optical channel. These optical channels are sent to a second optical add-drop multiplexer optically communicating with the second optical waveguide where they are added to the WDM optical signal propagating on the second waveguide.

BRIEF DESCRIPTION OF THE DRAWINGS:

FIG. 1 schematically depicts two WDM optical communication waveguides having a data bridge therebetween.

FIG. 2 schematically illustrates various series of data bits encoded on a first optical channel on a first waveguide used to encode two different optical channels on a second waveguide.

FIG. 3 depicts a further embodiment of the data bridge of the present invention employing a series of transponders as well as cell format and TDM format modules.

DETAILED DESCRIPTION:

Turning now to the drawings in detail in which like numerals indicate the same or similar elements, FIG. 1 depicts a wavelength division multiplexed optical communication network 10 according to a first embodiment of the present invention. Optical network 10 includes waveguides 20 and 120 and a bridge 200. Each optical transmission waveguide 20, 120 is configured to carry wavelength division multiplexed optical communication signals, each WDM signal comprised of plural optical channels at different wavelengths. In accordance with traditional industry nomenclature, one of the WDM signals propagating in a first direction is designated the west-east WDM signal while the WDM signal propagating in the opposite direction is designated the east-west WDM signal. The individual optical channels in the west-east WDM optical signal are denoted by the symbols λ_1 , λ_2 , λ_3 etc., while the individual optical channels in the east-

west WDM optical signal are denoted by the symbols λ_a , λ_b , λ_c , etc. for clarity of presentation. Although not shown in FIG. 1, it is common for optical networks to include at least two alternate optical paths- a "work" path and a "protect" path. Only one path is depicted in FIG. 1 although it is understood that at least an additional path may be provided along each waveguide. Each of the optical waveguides can form part of an optical ring network or other network topologies such as mesh networks, point-to-point networks, subtended ring networks, or any other network topology which includes at least two waveguides.

As used herein, the expression "wavelength division multiplexed" or "WDM" refers to any optical system or signal composed of plural optical channels having different wavelengths, regardless of the number of channels in the system or signal. As such, the term "wavelength division multiplexing" or "WDM" encompasses all categories of WDM such as DWDM (dense wavelength division multiplexing) and CWDM (coarse wavelength division multiplexing).

Optical add-drop multiplexer 220 is interposed along waveguide 20 to optically communicate with the waveguide for receiving a wavelength division multiplexed optical signal. As used herein, the expression "optically communicates" designates an optical path between two elements. The optical path may be a direct path or it may route through intermediate optical devices (e.g., optical isolators, additional optical circulators, filters, amplifiers, etc.). Optical add-drop multiplexer 220 may be selected from a number of devices depending upon the overall configuration of optical network 10. Considerations include the number of optical channels in the system, whether it is desired to drop a fixed number of channels of fixed wavelengths at the same drop point (or, conversely, a variable number of channels of different wavelengths), etc. In the simplest case, optical add-drop multiplexer 220 is configured to drop or add a single optical channel of a fixed wavelength. Such an add-drop multiplexer can take basic configuration of a three-port optical circulator and an optical coupler with an in-fiber Bragg grating disposed in a fiber connecting the devices. A unidirectional WDM signal enters the first circulator; a channel to be dropped is reflected by the grating to a drop port while the remaining channels of the WDM signal pass through to the coupler. A channel to be added enters the coupler and is output to the transmission waveguide where it joins the remaining channels of the WDM optical signal. Such a configuration

is depicted in Optical Networks: A Practical Perspective, incorporated by reference above. Of course, additional channels may be add-dropped by adding additional gratings corresponding to the wavelengths of the channels to be dropped (or variable gratings whose wavelength can be changed to select different wavelengths). While this is an
5 example of a single channel add-drop multiplexer which may be used with the present invention, it is understood that any device capable of selecting one or more optical channels from a WDM optical signal and/or adding an optical channel to a WDM optical signal is contemplated for use in the optical systems of the present invention.

A channel dropped from either the west-east or east-west WDM optical signal is
10 routed to an optical network interface 230. Optical network interface 230 includes at least one electrical to optical conversion element for converting the information carried by the optical channel into one or more electrical signals. In an exemplary embodiment, the west-east optical channel designated λ_1 carried on waveguide 20 is dropped by optical add-drop multiplexer 220. As seen from the schematic depiction of this optical
15 channel shown in FIG. 2, λ_1 is encoded with various data bit streams, labeled "data bits b," "data bits c," "data bits d," and "data bits e." The term "data," as used herein, broadly represents any type of information to be transmitted over an optical communication system including, but not limited to, voice, images, video, music, text, etc. Each of the data bit streams can be formatted in a variety of "data formats" which may be the same
20 or different. As defined in Telecommunication Transmission Systems, (Robert Winch, second edition, McGraw-Hill, NY© 1998), the disclosure of which is incorporated by reference herein, a protocol is "a set of rules that control a sequence of events which take place between equipment or layers on the same level." ATM (Asynchronous Transfer Mode), IP (Internet Protocol), MPLS (MultiProtocol Label Switching), TDM (Time
25 Division Multiplexing) are all examples of protocols used to carry data over optical networks. Within these protocols are various data formats which define how the individual bits of information are grouped in a signal (e.g., header bits, payload bits, identifier bits, routing information bits, Thus, for each protocol (e.g., ATM, IP, MPLS, TDM, etc.) there is an associated data format for that protocol. In the context of the
30 present invention, the use of the terms ATM, IP, MPLS, TDM, etc. refer to the data format associated with that protocol unless otherwise indicated. Further discussion of techniques for encoding optical channels with different data formats is described in

applicants' copending U.S. Patent Application Serial Number 09/688,804, the disclosure of which is incorporated by reference herein.

The information placed on optical channel λ_1 includes data configured in any of the data formats set forth above; in an exemplary embodiment the optical system is
5 constructed so that plural data formats can be simultaneously and independently placed on a single optical channel without conversion to another data format prior to placement on that channel. However, it is understood that bridge 200 may just as readily be implemented with data of a single format or data of multiple formats which have been converted to a single format.

10 The optical to electrical conversion element(s) in optical network interfaces 230 and 250 produce an electrical signal including all of the information from the corresponding optical channel(s) including data bit streams b, c, d, e; these data bit streams may be separated into plural electrical signals. Any element capable of taking an optical signal and producing one or more electrical signals encoded with the information
15 from the optical signal is contemplated for use in the present invention. Such optical to electrical conversion elements are well known and commercially available and will not be further described here. For the embodiment depicted in FIG. 2, two electrical signals are formed- one which includes data bit streams c and e and another which includes data bit streams b and d. Alternatively, plural electrical signals may be formed directly by the
20 optical-to-electrical conversion element without formation of an intermediate electrical signal containing all the information from the optical channel. The manner in which the electrical signals containing the desired data bit streams is not critical; therefore, any technique which results in the formation of electrical signals which include the data bit streams for use in modulating optical channels carried by the second optical waveguide.

25 To route the data bits encoded on λ_1 , carried by first waveguide 20 to the second waveguide 120, first optical network interface 230 electrically communicates with second optical network interface 250. As used herein, the expression "electrically communicates" denotes an electrical path between the devices regardless of the presence of additional electrical devices positioned therebetween. Further, particularly when data
30 of a single format is employed for all of the data bits, the system may be condensed into a single optical network interface positioned between optical add-drop multiplexers 220 and 240. The single optical network interface would include at least one optical to

electrical conversion element and at least two electrical to optical conversion elements; in this manner data bits encoded on the first optical channel could be separated and placed onto two optical channels using only one optical network interface.

Data bit streams b, c, d, and e are routed to optical network interface 250.

5 Optical network interface 250 includes at least two electrical to optical conversion elements for creating two optical channels designated λ_a and λ_b in an exemplary embodiment. Any device which is capable of forming one or more electrical signals from an optical signal is contemplated for use in the systems of the present invention. Optical network interface 250 encodes λ_a with data bit streams c and e and encodes λ_b
10 with data bit streams b and d. The data bit streams may be encoded on the optical channels through a wide variety of modulation techniques, including direct modulation techniques (e.g., varying a current source to a laser) or external modulation techniques (e.g., through Mach-Zehnder modulators, electroabsorption modulators, etc.). The technique for modulating the optical signal is not critical; therefore any technique
15 capable of encoding data onto an optical channel is contemplated for use in the present invention. Optical channels λ_a and λ_b are routed to optical add-drop multiplexer 240 where they are added to the optical channels carried by waveguide 120. The determination of which channels to encode with which data bit streams is dependent upon the final destination of the information; the optical network interface determines
20 the destination of the data and then decides which optical channel should carry that data.

When the optical channel is selected in accordance with SONET standards, the data bit streams are placed into a SONET-compatible slot on the optical channel. Alternatively, other types of optical channels may be selected such as those which use the digital wrapper standard; however, it is understood that the invention may be used
25 with any technique for multiplexing data onto an optical channel. Optical network interfaces 230 and 250 may each comprise a single apparatus or, optionally, plural apparatus which perform the functions described above. Further, as discussed above, when data of a single format is used, a single optical network interface may mutually serve waveguides 20 and 120. Although not explicitly shown in FIG. 1, when optical
30 channels λ_a and λ_b are added to waveguide 120, the same channels already propagating on that waveguide may be dropped. From there, the dropped channels may be routed elsewhere in optical network 10; alternatively, data bit streams carried on those channels

may be combined onto an optical channel to be added to waveguide 120 (especially an optical channel having the same wavelength, λ_1 , as the channel dropped by add-drop multiplexer 220.

As indicated in FIG. 1, the same process for routing data bit streams may also
5 occur for one or more optical channels dropped from waveguide 120. In an exemplary embodiment, the same number of channels having the same wavelengths are add/dropped from each of the optical waveguides. Data bit streams from each of the channels that are dropped from each waveguide are encoded onto various optical channels being added to the other waveguide. Alternatively, an unequal number of
10 optical channels can be add/dropped onto each waveguide.

Turning to FIG. 3, a further embodiment of the data bridge of the present invention is depicted. In the embodiment of FIG. 3, the optical network interface systems 330 and 350 include two subsystems: optical network interfaces 332 and 352 and transponder arrays 334 and 354, respectively. Optical add-drop multiplexers 320
15 and 340 are interposed along optical waveguides 20 and 120; in an exemplary embodiment, each add-drop multiplexer optically add/drops 4 optical channels from each waveguide. In this embodiment, west-east channels dropped from waveguide 20 have the same wavelength as east-west channels dropped from waveguide 120. In this manner, add-drop multiplexers 320 and 340 can include channel selectors configured for
20 the same wavelengths. It is noted that both a "work" and "protect" system are depicted in FIG. 3; because these systems are substantially similar, only the "work" system is described in this section.

Transponder arrays 334 and 354 both receive the optical channels dropped by add-drop multiplexers 320 and 340 and produce the optical channels to be added by the
25 add-drop multiplexers via optical paths 321, 322, 323, 324, 325, 326, 327, 328 and 391, 392, 393, 394, 395, 396, 397, and 398. These optical paths may be, for example, along one or more optical waveguides such as optical fibers. Transponder arrays 334 and 354 can include short-reach optical interfaces and interact with the optical network interfaces 332 and 352 through these short-reach optical signals which are carried by optical paths
30 371, 372, 373, 374, 375, 376, 377, 378 and 381, 382, 383, 384, 385, 386, 387, 388, respectively. Again, these optical paths may be along one or more optical waveguides such as optical fibers.

As in the embodiment depicted in FIG. 1, optical network interfaces 332 and 352 convert information encoded on the optical channels to electrical signals as seen by the optical to electrical conversion elements 333, 353 in FIG. 3; in the embodiment depicted in FIG. 3, electrical signals are formed from four optical channels selected from each of
5 optical waveguides 20 and 120. These selected optical channels are designated $\lambda_1, \lambda_2, \lambda_3, \lambda_4$, from waveguide 20 and $\lambda_a, \lambda_b, \lambda_c, \lambda_d$ from waveguide 120. In the embodiment shown in FIG. 3, the wavelengths of $\lambda_1, \lambda_2, \lambda_3, \lambda_4$ are selected to be the same as the wavelengths of $\lambda_a, \lambda_b, \lambda_c, \lambda_d$, respectively. When the optical channels carry information having different data formats, the optical network interfaces 332 and 352 can optionally
10 communicate with cell format modules 410, 430 and TDM format modules 420, 440 through electrical communication paths 413, 414, 415, 416, 423, 424, 425, 426 so that data having cell or TDM formats can be received from the optical network interfaces and be intelligently routed to optical channels created by electrical to optical conversion elements 334, 354 on the other optical waveguide. Although single cell format modules
15 410, 430 and TDM format modules 420, 440 are depicted in FIG. 3, a pair of cell format and TDM modules would typically be associated with each of the four optical channels being add-dropped by each optical add-drop multiplexer 320, 340; the remaining modules have been omitted for clarity of presentation. However, depending upon the particular implementation of the system, individual modules could be used to deal with
20 the cell format or TDM format portions of each of the four optical channels add-dropped on each waveguide. Routing the respectively formatted data bit streams through the TDM or cell format modules provides an effective technique for ensuring that TDM formatted data is not broken up into packets or cells, incurring additional overhead bits identifying the respective payloads as discussed in patent application 09/688,804,
25 incorporated by reference, above. Again, it is noted that the embodiment of FIG. 3 is used when more than one type of data format is used in the WDM network. As in the previous embodiment, elements 410, 420, 430 and 440 can be eliminated when optical channels in the network are encoded with a single data format. Alternatively, individual optical channels may each have a single data format with different channels carrying
30 different data formats.

Electrical communication paths 411, 412, 421, and 422 allow data to be sent across the bridge from one waveguide to another. The discontinuity schematically

indicated in these paths indicates that other devices may be optionally positioned between the modules, depending upon system implementation. For example, some of the data bit streams may be routed to a module for a different waveguide; similarly, data bit streams may be accepted from other optical channels on other waveguides at this point in the system. Alternatively, a series of line cards corresponding to each type of data format (e.g., IP, MPLS, ATM, GbE, etc.) can be interposed between the two modules 410, 430, 420, 440. Such cards are described in further detail in applicants' copending U.S. patent application 09/688,804, incorporated by reference above.

In another alternate embodiment, a single cell format module and TDM format module may be provided between optical network interfaces 332 and 352 (or a pair of modules for each optical channel. Such modules would be configured to route traffic from one waveguide to the other or reciprocally from each waveguide to the opposite waveguide.

In order to facilitate protection switching in the event of equipment or transmission line failure (e.g., fiber cut), an electrical cross-connect may optionally be provided interconnecting the cell and TDM format modules of the work system with the optical network interface of the protect system and interconnecting the cell and TDM format modules of the protect system with the optical network interface of the work system. In this way, data can be efficiently routed to the surviving optical path to prevent service interruption. Other electrical cross-connect configurations, such as between optical network interfaces when cell and TDM format modules are omitted, may also be used to enable protection switching.

As discussed above for FIG. 1, the same process for routing data bit streams may occur for one or more optical channels dropped from waveguide 120 in the optical network of FIG. 3. In an exemplary embodiment, the same number of channels having the same wavelengths are add/dropped from each of the optical waveguides. Data bit streams from each of the channels that are dropped from each waveguide are encoded onto various optical channels being added to the other waveguide. Alternatively, an unequal number of optical channels may be add/dropped onto each waveguide.

While the above invention has been described with reference to the particular exemplary embodiments, many modifications and functionally equivalent elements may be substituted without departing from the spirit and contributions of the present

invention. Accordingly, modifications and functionally equivalent elements such as those suggested above, but not limited thereto, are considered to be within the scope of the following claims.

WHAT IS CLAIMED IS:

1. An optical network including a bridge for selectively transferring information from an optical channel carried on a first wavelength division multiplexed optical waveguide to at least two optical channels on a second wavelength division multiplexed optical waveguide comprising:
- 5 a first optical waveguide carrying a first wavelength division multiplexed optical communication signal, the first wavelength division multiplexed optical communication signal comprising a plurality of first optical channels;
- a second optical waveguide carrying a second wavelength division multiplexed optical communication signal, the second wavelength division multiplexed optical communication signal comprising a plurality of second optical channels;
- 10 a bridge interposed between the first optical waveguide and the second optical waveguide, the bridge comprising:
- a first optical add-drop multiplexer optically communicating with the first optical waveguide for selecting at least a first optical channel from the first wavelength division multiplexed optical signal, the first optical channel including at least a first series of data bits and a second series of data bits encoded on the optical channel;
- 15 an optical network interface optically communicating with the first optical add-drop multiplexer, the first optical network interface including an optical to electrical conversion means for taking information from the first selected first optical channel and creating at least first and second electrical signals, the first electrical signal including the first series of data bits and the second electrical signal including the second series of data bits;
- 20 at least two electrical to optical conversion elements configured such that the first electrical signal encoded with the first series of data bits is used to modulate a second optical channel and the second electrical signal encoded with the second series of data bits is used to modulate a third optical channel;
- one or more electrical communication paths for routing the first and second electrical signals to the electrical-to-optical conversion elements;
- 30 a second optical add-drop multiplexer optically communicating with the second optical waveguide;

a second optical path between the second optical add-drop multiplexer and the at least two electrical to optical conversion elements for receiving the second and third optical channels and supplying them to the second optical add-drop multiplexer such that they added to the second optical waveguide.

5 2. An optical network as recited in claim 1 wherein the at least two electrical to optical conversion elements are part of the first optical network interface.

 3. An optical network as recited in claim 1 wherein the at least two electrical to optical conversion elements are part of a second optical network interface which optically communicates with the second optical add-drop multiplexer.

10 4. An optical network as recited in claim 3 further comprising cell format modules and TDM format modules interposed between the first and second optical network interfaces.

 5. An optical network including a bridge for selectively transferring information from an optical channel carried on a first wavelength division multiplexed optical
15 waveguide to at least two optical channels on a second wavelength division multiplexed optical waveguide comprising:

 a first optical waveguide carrying a first wavelength division multiplexed optical communication signal, the first wavelength division multiplexed optical communication signal comprising a plurality of first optical channels;

20 a second optical waveguide carrying a second wavelength division multiplexed optical communication signal, the second wavelength division multiplexed optical communication signal comprising a plurality of second optical channels;

 a bridge interposed between the first optical waveguide and the second optical waveguide, the bridge comprising:

25 a first optical add-drop multiplexer optically communicating with the first optical waveguide for selecting at least a first optical channel from the first wavelength division multiplexed optical signal, the first optical channel including at least a first series of data bits and a second series of data bits encoded on the optical channel;

 a first optical network interface optically communicating with the first
30 optical add-drop multiplexer, the first optical network interface including an optical to electrical conversion element for converting the selected first optical channel to a first electrical signal which includes the first and second series of data bits;

means for separating the first series of data bits from the second series of data bits and encoding a second electrical signal with the first series of data bits and encoding a third electrical signal with the second series of data bits;

5 one or more electrical communication paths situated between the separating means and a second optical network interface such that the second electrical signal and the third electrical signal electrically communicate with the second optical network interface, the second optical network interface including at least two electrical to optical conversion elements such that the second electrical signal encoded with the first series of data bits is used to modulate a second optical channel and the third electrical
10 signal encoded with the second series of data bits is used to modulate a third optical channel;

a second optical add-drop multiplexer optically communicating with the second optical waveguide;

15 a second optical path between the second optical add-drop multiplexer and the second optical network interface for receiving the second and third optical channels and supplying them to the second optical add-drop multiplexer such that they added to the second optical waveguide.

6. An optical network as recited in claim 5 further comprising cell format modules and TDM format modules interposed between the first and second optical
20 network interfaces.

7. An optical network including a bridge for selectively transferring information from an optical channel carried on a first wavelength division multiplexed optical waveguide to at least two optical channels on a second wavelength division multiplexed optical waveguide comprising:

25 a first optical waveguide carrying a first wavelength division multiplexed optical communication signal, the first wavelength division multiplexed optical communication signal comprising a plurality of first optical channels;

a second optical waveguide carrying a second wavelength division multiplexed optical communication signal, the second wavelength division multiplexed
30 optical communication signal comprising a plurality of second optical channels;

a bridge interposed between the first optical waveguide and the second optical waveguide, the bridge comprising:

a first optical add-drop multiplexer optically communicating with the first optical waveguide for selecting at least a first optical channel from the first wavelength division multiplexed optical signal, the first optical channel including at least a first series of data bits and a second series of data bits encoded on the optical channel;

5 a first transponder interface optically communicating with the first optical add-drop multiplexer for receiving the first optical channel dropped from the add-drop multiplexer and producing a corresponding first short-reach optical signal to be output onto a first optical path from the transponder;

10 a first optical network interface optically communicating with the first transponder interface, the first optical network interface including an optical to electrical conversion element for converting the optical signal received from the first transponder interface to a first electrical signal which includes the first and second series of data bits;

15 means for separating the first series of data bits from the second series of data bits and encoding a second electrical signal with the first series of data bits and encoding a third electrical signal with the second series of data bits;

20 one or more electrical communication paths situated between the separating means and a second optical network interface such that the second electrical signal and the third electrical signal electrically communicate with the second optical network interface, the second optical network interface including at least two electrical to optical conversion elements such that the second electrical signal encoded with the first series of data bits is used to modulate a second short-reach optical signal and the third electrical signal encoded with the second series of data bits is used to modulate a third short-reach optical signal;

25 a second transponder interface optically communicating with the second optical network interface for receiving the second and third short-reach optical signals and converting them into second and third optical channels;

a second optical add-drop multiplexer optically communicating with the second optical waveguide;

30 a second optical path between the second optical add-drop multiplexer and the second transponder interface for receiving the second and third optical channels and supplying them to the second optical add-drop multiplexer such that they added to the second optical waveguide.

8. An optical network as recited in claim 7 further comprising cell format modules and TDM format modules interposed between the first and second optical network interfaces.

FIG. 1

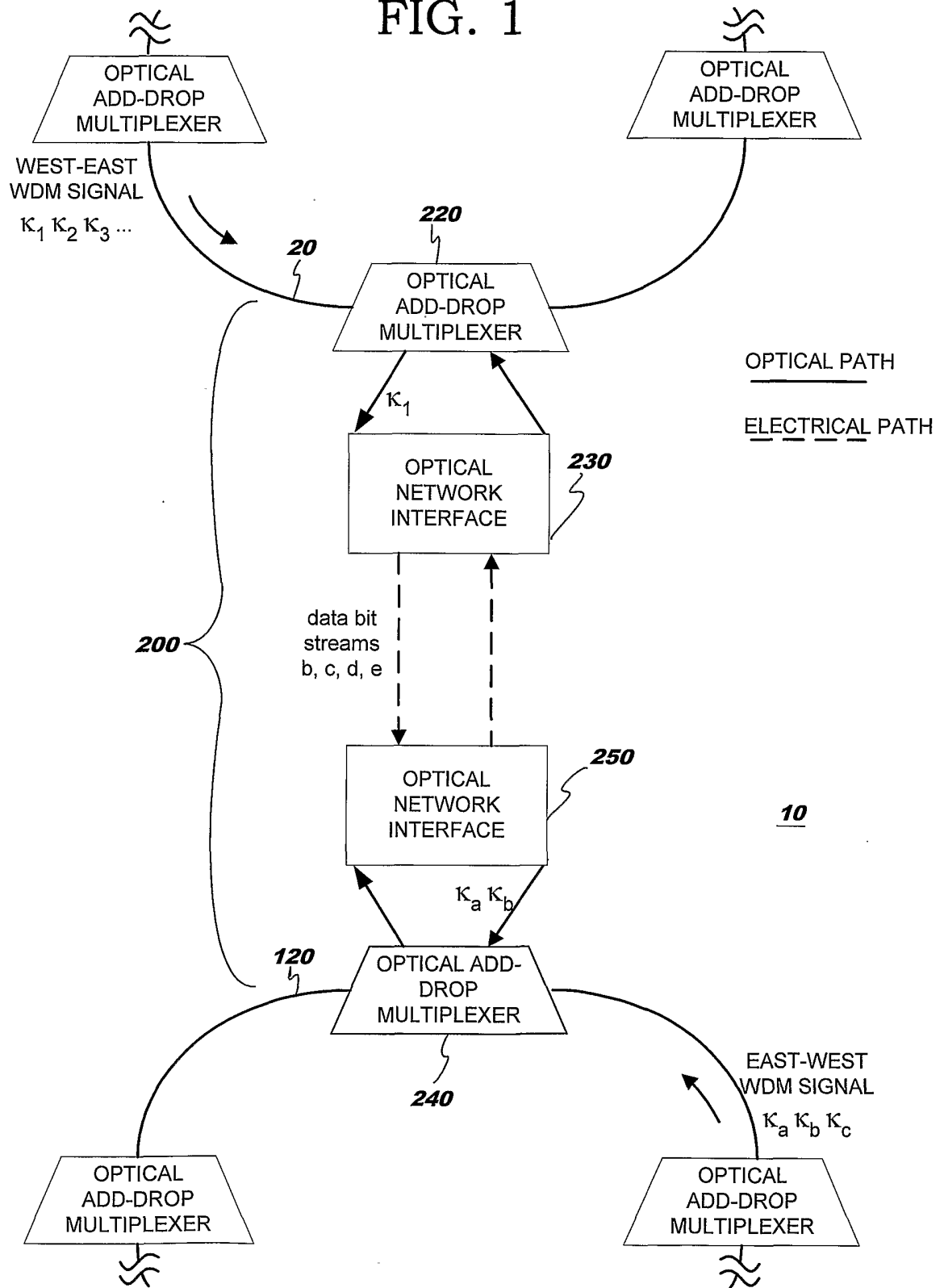
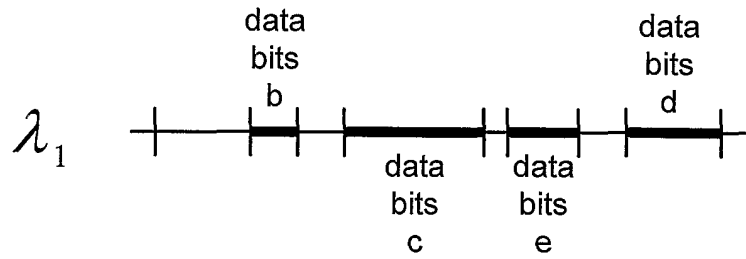
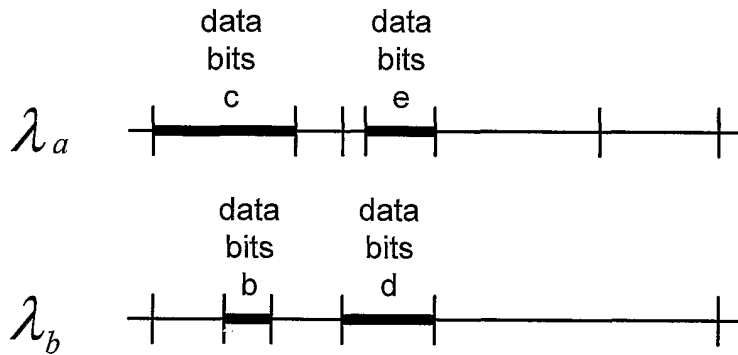
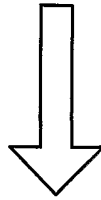

FIG. 2



FIRST WAVEGUIDE CARRYING WDM SIGNAL



SECOND WAVEGUIDE CARRYING WDM SIGNAL

FIG. 3

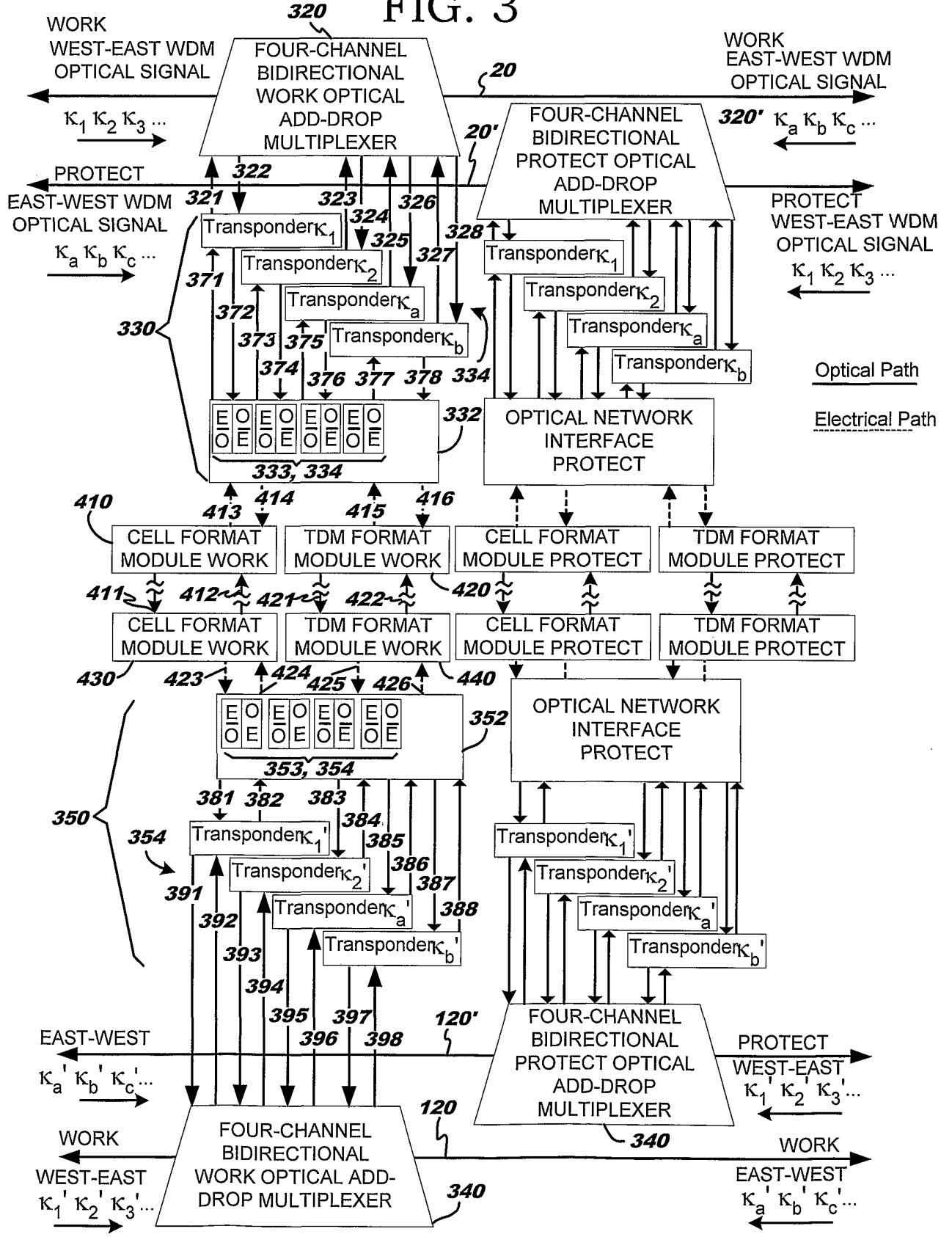

INTERNATIONAL SEARCH REPORT

International application No.

PCT/US01/45752

| A. CLASSIFICATION OF SUBJECT MATTER | | |
|--|--|--|
| IPC(7) : H04J 14/02 | | |
| US CL : 359/119, 123, 124 | | |
| According to International Patent Classification (IPC) or to both national classification and IPC | | |
| B. FIELDS SEARCHED | | |
| Minimum documentation searched (classification system followed by classification symbols) U.S. : 359/119, 123, 124, 127, 130, 134 | | |
| Documentation searched other than minimum documentation to the extent that such documents are included in the fields searched | | |
| Electronic data base consulted during the international search (name of data base and, where practicable, search terms used) Please See Continuation Sheet | | |
| C. DOCUMENTS CONSIDERED TO BE RELEVANT | | |
| Category * | Citation of document, with indication, where appropriate, of the relevant passages | Relevant to claim No. |
| A, P | US 6,202,082 B1 (TOMIZAWA et al) 13 March 2001, see figure 14. | 1-8 |
| A, P | US 6,160,660 A (AINA et al) 12 December 2000, see figure 2. | 1-8 |
| A | US 6,101,012 A (DANAGHER et al) 08 August 2000, see figure 2. | 1-8 |
| A | US 6,084,694 A (MILTON et al) 04 July 2000, see figure 1 and 3-9. | 1-8 |
| A | US 5,812,306 A (MIZRAHI) 22 September 1998, see figure 1. | 1-8 |
| A, P | US 6,169,616 B1 (CAO) 02 January 2001, see figures 3a-7. | 1-8 |
| <input type="checkbox"/> Further documents are listed in the continuation of Box C. <input type="checkbox"/> See patent family annex. | | |
| * Special categories of cited documents: | | |
| "A" document defining the general state of the art which is not considered to be of particular relevance "E" earlier application or patent published on or after the international filing date "L" document which may throw doubts on priority claim(s) or which is cited to establish the publication date of another citation or other special reason (as specified) "O" document referring to an oral disclosure, use, exhibition or other means "P" document published prior to the international filing date but later than the priority date claimed | "T" later document published after the international filing date or priority date and not in conflict with the application but cited to understand the principle or theory underlying the invention "X" document of particular relevance; the claimed invention cannot be considered novel or cannot be considered to involve an inventive step when the document is taken alone "Y" document of particular relevance; the claimed invention cannot be considered to involve an inventive step when the document is combined with one or more other such documents, such combination being obvious to a person skilled in the art "&" document member of the same patent family | |
| Date of the actual completion of the international search | | Date of mailing of the international search report |
| 14 March 2002 (14.03.2002) | | 12 APR 2002 |
| Name and mailing address of the ISA/US Commissioner of Patents and Trademarks Box PCT Washington, D.C. 20231 Facsimile No. (703)305-3230 | | Authorized officer <i>Leslie Pascal</i> Telephone No. 703-305-4700 |

INTERNATIONAL SEARCH REPORT

International application No.

PCT/US01/45752

Continuation of B. FIELDS SEARCHED Item 3:

EAST

search terms ((a adj d) or (add\$ adj drop\$) or adm\$) and bridge\$ and ((wavelength adj division) or WDM)
((a adj d) or add\$ adj drop\$) or adm\$) and 359/123-134.ccls.