

(19) World Intellectual Property Organization
International Bureau



(43) International Publication Date
16 June 2011 (16.06.2011)

PCT

(10) International Publication Number
WO 2011/071974 A2

(51) International Patent Classification:
B22C 9/02 (2006.01) B22C 9/24 (2006.01)
B22C 9/10 (2006.01)

(74) Agents: SWANSON, Erik, C. et al.; Siemens Corporation- Intellectual Property Dept., 170 Wood Avenue South, Iselin, New Jersey 08830 (US).

(21) International Application Number:
PCT/US2010/059377

(81) Designated States (unless otherwise indicated, for every kind of national protection available): AE, AG, AL, AM, AO, AT, AU, AZ, BA, BB, BG, BH, BR, BW, BY, BZ, CA, CH, CL, CN, CO, CR, CU, CZ, DE, DK, DM, DO, DZ, EC, EE, EG, ES, FI, GB, GD, GE, GH, GM, GT, HN, HR, HU, ID, IL, IN, IS, JP, KE, KG, KM, KN, KP, KR, KZ, LA, LC, LK, LR, LS, LT, LU, LY, MA, MD, ME, MG, MK, MN, MW, MX, MY, MZ, NA, NG, NI, NO, NZ, OM, PE, PG, PH, PL, PT, RO, RS, RU, SC, SD, SE, SG, SK, SL, SM, ST, SV, SY, TH, TJ, TM, TN, TR, TT, TZ, UA, UG, US, UZ, VC, VN, ZA, ZM, ZW.

(22) International Filing Date:
8 December 2010 (08.12.2010)

(25) Filing Language: English

(26) Publication Language: English

(30) Priority Data:
61/267,717 8 December 2009 (08.12.2009) US
12/961,621 7 December 2010 (07.12.2010) US

(71) Applicants (for all designated States except US):
SIEMENS ENERGY, INC. [US/US]; 4400 Alafaya Trail, Orlando, Florida 32826-2399 (US). MIKRO SYSTEMS, INC [US/US]; 1180 Seminole Trail, Suite 220, Charlottesville, VA 22901 (US).

(84) Designated States (unless otherwise indicated, for every kind of regional protection available): ARIPO (BW, GH, GM, KE, LR, LS, MW, MZ, NA, SD, SL, SZ, TZ, UG, ZM, ZW), Eurasian (AM, AZ, BY, KG, KZ, MD, RU, TJ, TM), European (AL, AT, BE, BG, CH, CY, CZ, DE, DK, EE, ES, FI, FR, GB, GR, HR, HU, IE, IS, IT, LT, LU, LV, MC, MK, MT, NL, NO, PL, PT, RO, RS, SE, SI, SK, SM, TR), OAPI (BF, BJ, CF, CG, CI, CM, GA, GN, GQ, GW, ML, MR, NE, SN, TD, TG).

(72) Inventors; and

(75) Inventors/Applicants (for US only): MERRILL, Gary B. [US/US]; 2413 Flowering Dogwood Drive, Orlando, Florida 32828 (US). APPLEBY, Michael P. [US/US]; 3435 Carr's Ridge Road, Crozet, Virginia 22932 (US). FRASER, Iain A. [US/US]; 158 Greene Court, Ruckersville, Virginia 22968 (US). KLINGER, Jill [US/US]; 201 Palatine Avenue, Charlottesville, Virginia 22902 (US). PAULUS, John R. [US/US]; 978 Smith Road, Afton, Virginia 22920 (US).

Published:

— without international search report and to be republished upon receipt of that report (Rule 48.2(g))

(54) Title: WAXLESS PRECISION CASTING PROCESS

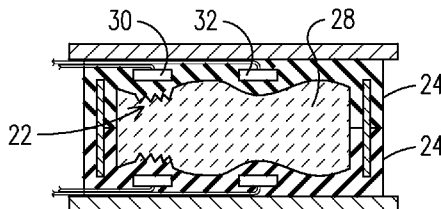

FIG. 1F

(57) Abstract: Alloy products are produced with a waxless casting process. A model of a ceramic casting vessel (34) defining a desired product shape is digitally divided into sections (10, 40, 42). Each section is translated into a soft alloy master tool (14) including precision inserts (20) where needed for fine detail. A flexible mold (24) is cast from each master tool, and a section of the ceramic casting vessel is cast from the respective flexible mold. The vessel sections are assembled by aligning cooperating precision features (58, 60) cast directly into each section and the alloy part is cast therein. No wax or wax pattern tooling is needed to produce the cast alloy product. Engineered surface features (54) may be included on both the interior and exterior surfaces of the shell sections



WO 2011/071974 A2

WAXLESS PRECISION CASTING PROCESS

This application claims benefit of the 08 December 2009 filing date of United States provisional patent application number 61/267,717, the entire disclosure of which is incorporated by reference herein.

FIELD OF THE INVENTION

This invention relates to the field of investment casting.

BACKGROUND OF THE INVENTION

Investment casting is one of the oldest known alloy-forming processes, dating back thousands of years to when it was first used to produce detailed artwork from alloys such as copper, bronze and gold. Industrial investment castings became more common in the 1940's when World War II increased the demand for precisely dimensioned parts formed of specialized alloy alloys. Today, investment casting is used in the aerospace and power industries to produce gas turbine components such as blades having complex airfoil shapes and internal cooling passage geometries.

The production of a gas turbine blade using the prior art investment casting process (also called lost-wax casting) involves producing a ceramic casting vessel having an outer ceramic shell, corresponding to the airfoil shape of the blade, and one or more ceramic cores positioned within the outer ceramic shell, corresponding to interior cooling passages to be formed within the blade. Molten high temperature alloy is introduced into the ceramic casting vessel using high pressure injection and is then allowed to cool and to harden. The outer ceramic shell and ceramic core(s) are then removed by mechanical or chemical means to reveal the cast blade having the external airfoil shape and hollow interior cooling passages in the shape of the ceramic core(s).

The ceramic core(s) for this process is manufactured by first precision machining the desired core shape into mating core mold halves formed of high strength hardened machine steel, then joining the mold halves to define an injection volume corresponding to the desired core shape, and vacuum injecting a ceramic molding material into the injection volume. The molding material is a mixture of ceramic powder and binder material. Once the

ceramic molding material has hardened to a green state, the mold halves are separated to release the green state ceramic core. The fragile green state core is then thermally processed to remove the binder and to sinter the ceramic powder together to develop the strength necessary for the core to survive further handling and subsequent use during the investment casting process.

The complete ceramic casting vessel is formed by positioning the ceramic core within the two joined halves of another precision machined hardened steel mold (referred to as the wax mold or wax pattern tooling) which defines an injection volume that corresponds to the desired airfoil shape of the blade, and then vacuum injecting melted wax into the wax mold around the ceramic core. Once the wax has hardened, the wax mold halves are separated and removed to reveal the wax pattern, which includes the ceramic core encased inside the wax, with the wax pattern outer surface now corresponding to the airfoil shape. The outer surface of the wax pattern is then coated with a ceramic mold material, such as by a dipping process, to form the ceramic shell around the wax pattern. Upon hardening of the shell and removal of the wax by melting or other means, the completed ceramic casting vessel is available to receive molten steel alloy in the investment casting process, as described above.

The known lost-wax investment casting process is expensive and time consuming, with the development of casting molds for a new blade design typically taking many months and hundreds of thousands of dollars to complete. Furthermore, gas turbine blade design choices are restricted by process limitations in the production of ceramic cores because of their fragility and an inability to achieve acceptable yield rates for cores having fine features or large sizes. The alloys forming industry has recognized these limitations and has developed at least some incremental improvements, such as the improved process for casting airfoil trailing edge cooling channels described in United States patent 7,438,527. As the market demands ever higher efficiency and power output from gas turbine engines, the limitations of existing investment casting processes become ever more problematic.

SUMMARY OF THE INVENTION

While incremental improvements have been presented in the field of investment casting technology, the present inventors have recognized that the industry is faced with fundamental limitations that will significantly inhibit component designs for the next generation of gas turbine engines. For example, gas turbine firing temperatures continue to be increased in order to improve the efficiency of combustion, and component sizes continue to increase as power levels are raised, so there is now a need to design an internally cooled 4th stage gas turbine blade in excess of a meter in length. No such blade has heretofore been produced, nor is it believed that such a blade can be produced economically with existing technology. In prior art turbines, there was no need for internal cooling of the 4th stage due to the high temperature capability of available superalloys and the use of externally applied ceramic thermal barrier coatings. Due to increased firing temperatures, the next generation 4th stage turbine blades will exceed the operating limits of known steels and coatings and will require active internal cooling passages to protect the integrity of the component. However, due to the projected size of these new blades and the intricacy of the desired cooling passages, the ceramic cores that would be necessary for investment casting of such cooling passages are beyond the commercially practical capabilities of existing investment casting processes.

As a result, the present inventors have developed an entirely new regiment for precision component casting. This new regiment not only extends and refines existing capabilities, but it also provides new and previously unavailable design practicalities for the component designer. Furthermore, this new regiment eliminates the need for the time consuming and costly wax pattern injection process. As a result, the waxless process disclosed herein enables the timely and cost efficient production of cast alloy alloy components having feature geometries that may be larger or smaller than currently available geometries, may be more complex or shapes that could never before have been cast, and may have feature aspect ratios that were previously unattainable but that are now needed for the very long and thin cooling passages in a 4th stage internally cooled gas turbine blade. The present invention moves casting technology beyond foreseeable needs, and it

removes the casting process from being a design limitation, thereby allowing designers again to extend designs to the limits of the material properties of the cast alloys and the externally applied thermal barrier coatings.

The casting regiment described herein incorporates new and improved processes at multiple steps in the casting process. Specific aspects of the new regiment are described and claimed in greater detail below; however, the following summary is provided to familiarize the reader with the overall process so that the benefit of the individual steps and synergies there between may be appreciated.

An exemplary casting process according to a regiment described herein may start with the manufacturing of a ceramic core for a casting vessel by using a master mold which is machined from a relatively soft, easily machined, and inexpensive material, when compared to the currently used high strength machine steel. Examples of such soft alloys are aluminum and mild steels. Two master mold halves are formed, one corresponding to each of two opposed sides of a desired ceramic core shape. Into each master mold a flexible mold material is cast to form two cooperating flexible mold halves, which when joined together define an interior volume corresponding to the desired ceramic core shape. Ceramic mold material is then cast into the flexible mold and allowed to cure to a green state.

The cost and time to produce the master molds is minimized by the use of materials that are easily machined. However, advanced design features for the next generation of gas turbine engines may not translate well using standard machining processes in such materials. Accordingly, at least a portion of the master mold halves may be designed to receive a precision formed insert, and the insert may be formed using a Tomo process, as described in United States patents 7,141,812 and 7,410,606 and 7,411,204, all assigned to Mikro Systems, Inc. of Charlottesville, Virginia, and incorporated by reference herein. This technology is commonly referred to as Tomo Lithographic Molding Technology (hereinafter referred to as the "Tomo process"), and it involves the use of a metallic foil stack lamination mold to produce a flexible derived mold, which in turn is then used to cast a component part. In this manner, portions of the ceramic core which have a relatively low level of detail, such as long smooth channel sections, may be

translated into the master mold using inexpensive standard machining processes in the soft alloy mold, while other portions of the ceramic core having a relatively high level of detail, such as micro-sized surface turbulators or complex passage shapes, may be translated into the master mold using a Tomo-derived mold insert. Furthermore, for cooling channel designs requiring the use of multiple cores, the Tomo process mold inserts may be used to define precision cooperating joining geometries in each of the multiple cores so that when the multiple cores are jointly positioned within a ceramic casting vessel, the joining geometries of the respective cores will mechanically interlock such that the multiple cores function as a single core during the subsequent alloy injection process.

Another enabling technology that is exploited in the present casting regiment is described in pending International Patent Application PCT/US2009/58220 also assigned to Mikro Systems, Inc. of Charlottesville, Virginia, and incorporated by reference herein. That application describes a ceramic molding composition that mimics existing ceramic core molding materials in its slurry and fully sintered condition, but that provides significantly improved green body strength when compared to the existing materials. Incorporating such an improved molding composition into the present casting regiment facilitates the production of core geometries that would not previously have survived handling in their green state without an unacceptably high failure rate. Improved green state strength is particularly important during the removal of a ceramic core from a flexible mold when the shape of a core feature is such that the mold must be deformed around the cast material in order to remove the core from the mold.

With prior art processes, the ceramic core produced as described above might then be positioned within a wax pattern mold to produce a core/wax pattern by injecting melted wax into the wax pattern mold around the ceramic core. The wax pattern would then be dipped into ceramic slurry to produce a ceramic shell around the wax to define the ceramic casting vessel. However, the waxless casting process described and claimed herein completely eliminates the use of wax and wax pattern tooling. In its place, the ceramic shell is formed directly using processes similar to those described above for the production of the ceramic core, and the ceramic shell and

ceramic core are then joined together using cooperating alignment features to form the ceramic casting vessel without the need for any wax pattern. It is well known that the wax pattern production and wax injection processes are expensive and time consuming, and that yield rates are adversely affected by damage to the ceramic core associated with the wax injection process. By eliminating the use of wax completely, the present waxless casting process offers the potential for cost, schedule and yield rate improvements when compared to traditional lost-wax investment casting techniques. Furthermore, a ceramic casting vessel produced by the present method can be designed to have engineered exterior geometric features that enhance its functionality when compared to the featureless blob shape produced by the prior art dipping process. Details of the waxless precision casting process and other advantages over the prior art are disclosed below.

BRIEF DESCRIPTION OF THE DRAWINGS

The invention is explained in detail in the following description in view of the drawings that show:

FIGs. 1A - 1F illustrate steps for manufacturing a ceramic core for an investment casting process.

FIGs. 2A - 2I illustrate steps of a waxless precision casting process.

FIG. 3 illustrates cooperating engineered surface features on two adjoining ceramic casting vessels.

Fig. 4 illustrates the joining of three pieces of a sectioned ceramic casting vessel.

FIG. 5 is a first patterned surface generated from Tomo-process flexible tooling.

FIG. 6 is a second patterned surface generated from Tomo-process flexible tooling.

FIG. 7 is a patterned surface with a protruding surface pattern.

FIGs. 8A - 8C show surfaces derived from a single master tool subjected to progressive grit blasting.

FIG. 9 illustrates a ceramic casting vessel containing exterior features used during a subsequent dipping process.

FIG. 10 illustrates a ceramic casting vessel defining a non-linear cooling channel.

FIG. 11 is a comb-shaped insert defining the shape of a plurality of non-linear cooling channels.

DETAILED DESCRIPTION OF THE INVENTION

Exemplary Casting Process

The waxless precision casting process disclosed herein includes the use of relatively inexpensive master tools made from easily machined soft alloy material, such as aluminum, with optional high precision feature inserts. The master tools are used to cast intermediate flexible molds, which in turn are used to cast respective sections of a ceramic casting vessel. The vessel sections are then assembled to form a complete ceramic casting vessel, with precise alignment of the sections facilitated by cooperating alignment features.

An exemplary embodiment of the invention discussed herein is the fabrication of a gas turbine blade, which is a hollow alloy component having interior cooling passages; however, one will appreciate that the invention is not so limited and may be used for the fabrication of various hollow and solid components. The present waxless casting process is first described in part under this subheading with reference made to the fabrication of a ceramic core portion of a ceramic casting vessel for a gas turbine blade. Similar steps are then used to fabricate the other sections of the ceramic casting vessel and the sections are then joined together, as is discussed in more detail under additional subheadings below.

FIG. 1A-1F illustrates steps of a process for manufacturing a ceramic core section of a ceramic casting vessel for a waxless casting process. A digital model of a part such as a ceramic core 10 having a desired shape, as shown in FIG. 1A, is formed using any known computerized design system 12 as in FIG. 1B. That model is digitally divided into at least two parts, usually in half, and alignment features may be added to the digital model for subsequent joining of the two halves. Master tooling 14 is produced from the digital models using traditional machining processes and a relatively low cost and

easy to machine soft alloy material such as aluminum or soft steel. The master tooling incorporates the alignment features 16 and its surface 18 reflects the shape of the part. If a desired surface feature of the master tool has a relatively high precision requirement with dimensional tolerances smaller than those achievable with the traditional machining processes, a precision formed insert 20 may be installed into the master tool to incorporate the desired surface feature 22. The insert may be formed using a Tomo process, stereo lithography, direct alloy fabrication or other high precision process capable of maintaining dimensional tolerances smaller than those achievable with traditional machining processes such as milling or grinding. The overall tool surface is then a hybrid of the machined surface and the insert surface, as shown in FIG. 1C where each half of the master tooling contains a precision formed insert. Flexible molds 24 are then cast from the master tools, as shown in FIG. 1D, and both the low precision and high precision features are replicated into the flexible molds. The flexible molds are then co-aligned and drawn together to define a cavity 26 corresponding to the desired core shape, as shown in FIG. 1E. The cavity is filled with a slurry of ceramic casting material 28, as shown in FIG. 1F. The flexible molds are separated once the ceramic casting material has cured to a green state to reveal the ceramic core. The ceramic core replicates surface features that were first produced in the precision mold inserts, such as a complex surface topography or a precision formed joint geometry, for example a dovetail joint, useful for mechanical joining with a corresponding geometry formed in a mating core segment. The ceramic material cast into the flexible mold has adequate green body strength to allow such cast features to be removed from the mold even when they contain protruding undercuts or non-parallel pull plane features requiring some bending of the flexible mold during removal of the green body ceramic core. Master tool inserts may also be useful for rapid prototype testing of alternative design schemes during development testing where the majority of a core remains the same but alternative designs are being tested for one portion of the core. In lieu of manufacturing a completely new master tool for each alternative design, only a new insert need be formed.

Prior art investment casting processes require the use of high cost, difficult to machine, hard, tool steel material for the master tool because multiple ceramic cores are cast directly from a single master tool using a high pressure injection process. In contrast, the present invention uses the master tool only for low pressure or vacuum assisted casting of flexible (e.g. rubber) mold material, as described in the above-cited United States patents 7,141,812 and 7,410,606 and 7,411,204. Thus, low strength, relatively soft, easy to machine soft alloy materials may be used for the master tool, for example, a series 7000 aluminum alloy in one embodiment. This results in a significant time and cost savings when compared to prior art processes.

A ceramic casting material such as described in the above-cited International Patent Application PCT/US2009/58220 exhibits a lower viscosity than prior art ceramic core casting materials, thereby allowing the step of FIG. 1F to be performed at low pressure, such as at 10-15 psi. In contrast, prior art ceramic core material injection is typically performed at pressures an order of magnitude higher. The present inventors have found that a vibration assisted injection of the ceramic casting material is helpful to ensure smooth flow of the material and an even distribution of the ceramic particles of the material throughout the mold cavity. The flexibility of the molds facilitates imparting vibration into the flowing casting material. Vibration of the flexible mold may also be effective to displace air entrapped by a protruding surface of the flexible mold with the ceramic casting material slurry. In one embodiment, one or more small mechanical vibrators 30 as are known in the art are embedded into the flexible mold 24 during production of the molds in the step of FIG. 1D. The vibrator(s) may then be activated during the FIG. 1F injection of the ceramic casting material in a pattern that improves the flow of the slurry and the distribution of the ceramic particles of the slurry throughout the mold. In addition to or in lieu of the vibrators, other types of active devices 32 may be embedded into the flexible mold, for example any type of sensor (such as a pressure or temperature sensor), a source of heat or a source of cooling, and/or telemetry circuitry.

In one embodiment, the epoxy content of the ceramic casting material could range from 28 weight % in a silica based slurry to as low as 3 weight %. The silicone resin may be a commercially available material such as sold

under the names Momentive SR355 or Dow 255. This content could range from 3 weight % to as high as 30 weight %. The mix may use 200 mesh silica or even more coarse grains. Solvent content generally goes up as other resins decrease to allow for a castable slurry. The solvent is used to dissolve the silicon resin and blend with the epoxy without a lot of temperature. The Modulus of Rupture (MOR) of the sintered material is on the norm for fired silica, typically 1500-1800 psi with 10% cristobalite on a 3-point test rig. The sintered material MOR is tightly correlated to the cristobalite content, with more cristobalite yielding weaker room temperature strength. The green state MOR depends on the temperature used to cure the epoxy, as it is a high temperature thermo cure system. The curing temperature may be selected to allow for some thermo-forming, i.e. reheating the green state material to above a reversion temperature of the epoxy to soften the material, then bending it from its as-cast shape to a different shape desired for subsequent use. The reheated material may be placed into a setting die within a vacuum bag such that the part is drawn into conformance with the setting die upon drawing a vacuum in the bag. Alignment features may be cast into the core shape for precise alignment with the setting die. The green body casting material exhibits adequate strength for it to undergo standard machining operations that may be used to add or reshape features to the green body either before or after reshaping in a setting die. Following such thermo-forming or in the absence of it, additional curing may be used to add strength. In one embodiment the Modulus of Rupture achieved was:

MOR cured at 110 °C for 3 hours = 4000 psi

MOR cured as above and then at 120 °C for 1 hour = 8000 psi.

A 10% as-fired cristobalite content may be targeted. This may be altered by the mineralizers present and the firing schedule. The 10% initial cristobalite content may be used to create a crystalline seed structure throughout the part to assure that most of the rest of the silica converts to cristobalite in a timely fashion when the core is heated prior to pouring molten alloy into the ceramic mold. It also keeps the silica from continuing to sinter into itself as it heats up again.

Another parameter of concern in the investment casting business is porosity. Prior art ceramic casting material typically has about 35% porosity.

The material described above typically runs around 28% porosity. The danger of a low porosity is that the cast alloy cannot crush the ceramic core as it shrinks and cools, thereby creating alloy crystalline damage that is referred to in the art as "hot tear". The material described above has never caused such a problem in any casting trial.

The above described regiment for producing investment casting ceramic cores compares favorably with known prior art processes, as summarized in the following Table 1.

<u>Prior Art Characteristic</u>	<u>Invention Characteristic</u>	<u>Prior Art Capability</u>	<u>Invention Capability</u>
Hard Precision Tooling (high hardness machine tool steel)	Soft Precision Tooling (aluminum master, flexible derived mold)	Single pull plane per section necessitating multiple tool sections.	Multiple pull plane capability reduces tool sections, increases design freedom
		Linear extraction only.	Curvilinear extraction capability.
		Single cross section pull plane.	Multiple cross section pull planes.
		Rigid, durable wear resistant casting cavity for HP and IP injection processes.	Flexible casting cavity for low pressure, vibration assisted molding.
Low green body strength	High green body strength	Limited aspect ratio	Substantially enhanced aspect ratio capability
		Yield losses related to low green strength	Green strength losses eliminated
		Limited	Joinability of

		joinability of core sub assemblies (butt joints only).	subassemblies enhanced through structural joint designs.
High viscosity of core material slurry	Low viscosity of core material slurry	Requires pressurized injection, prone to segregation (section thickness sensitive)	Low pressure injection (vacuum assisted), promotes particle size homogeneity throughout structure, section thickness insensitive
		Promotes non-uniform shrinkage during thermal processing	Promotes uniform shrinkage during thermal processing
		Dimensional tolerance of fired parts tailored to process limitations	Potentially improves dimensional tolerance of fired parts
No Green body flexibility	Thermo-formable after green body formation	None	Green body can be adjusted/modified using simple form tools
Precision machined tool steel die to form mold cavity	Aluminum master tool with high definition inserts used to generated flexible mold which is then used to form mold	Very high cost and long lead time	Low cost and short lead time

	cavity		
		Inflexible tool set, high cost to modify.	Low cost modular modifications/alterations allowed
		Rigid mold cavity good for high pressure injection	Flexible mold cavity for low pressure and vibration assisted injection.
		Extraction requires enhanced tooling	Versatile extraction due to flexible mold.

TABLE 1

The multi-step casting process described above with respect to the fabrication of the ceramic core section of a ceramic casting vessel is then further applied to the fabrication of all sections of the vessel to enable a totally waxless precision casting process, as more fully described below.

Waxless Casting Process Overview

In a process containing steps similar to those of FIGs. 1A-1F, an entire ceramic casting vessel is produced in sections which are then joined together for casting of the alloy alloy. For a hollow component such as a gas turbine blade, the casting vessel includes a ceramic core and a shell. FIG. 2A-2G illustrates steps in an exemplary method of waxless precision casting of a gas turbine blade. FIG. 2A is a cross-sectional representation of a computerized digital model of a ceramic casting vessel 34 showing an outer shell 36 having an inner surface 38 defining the desired exterior shape of a gas turbine blade and an inner core 10 defining the shape of a hollow center cooling channel of the blade. That digital model can be sectioned as appropriate to facilitate the fabrication of a like-shaped ceramic casting vessel, such as by digitally splitting the shell into suction side 40 and pressure side 42 halves as shown in FIG. 2B. It will be appreciated that the location of the splits in the digital model may vary for any particular design, and may be determined by

considering factors such as component stress levels, ease of fabrication and assembly of the subsections, the effect of joint lines at a particular location, the ability to design special joint features at a particular location such as reinforcing interlocking joints, etc.

Because the ceramic material utilized to cast the ceramic casting vessel may allow for thermal reshaping after it has reached the green body state, as discussed above, portions of the digital model optionally may be flattened in order to facilitate the fabrication of certain designs, such as as shown in FIG. 2C where the shell halves 40, 42 have been digitally flattened. The flattened model is used to create a flattened ceramic part which is then returned to the desired curvature during an optional thermal shaping process. This effect may be exaggerated to form a wrap-around tab style locking feature which can be deformed to interface with a cooperating feature to reinforce a joint, for example.

A master tool is then fabricated in the shape of each of the digital model sections 10, 40, 42 of FIG. 2C. As discussed above, the master tool may be fabricated from low cost, easily machined, relatively soft alloy material, such as aluminum. In regions of a tool where a precision geometric detail is desired which can not be effectively produced with standard machining processes, a precision insert 20 may be created and inserted into the low cost aluminum tool, as shown in FIG. 2D1, which is a side view of the suction side 40 shell wall of FIG. 2B or 2C. Alternatively, the entire master tool 44 may be created using a precision process such as a Tomo process, as shown in FIG. 2D2, which is an alternative embodiment of a side view of a suction side shell wall of FIG. 2B or 2C.

Flexible molds 24 are then derived from each of the master tools as described above with respect to the fabrication of the ceramic core. FIG. 2E1 illustrates an exterior side of the suction side shell wall master tool 40 being used to cast an exterior section 24' of a flexible mold, and FIG. 2E2 illustrates an interior side of the suction side shell wall master tool 40 being used to cast an interior section 24" of the flexible mold. Cooperating alignment features 16 are formed into each of the flexible mold sections to facilitate subsequent assembly of the flexible mold. One may appreciate that in lieu of a two-sided master tool, two one-sided master tools may be used in an alternative

embodiment. FIG. 2F shows the two sections of the flexible mold being joined together to define the casting cavity 26 ready for low pressure injection of the ceramic casting material to form the suction side shell wall. As described above with regard to the casting of the ceramic core, an epoxy-based ceramic casting material having a degree of green body strength may be cast into the flexible mold to allow for the formation of precision complex features on the surfaces of the shell wall. The green body suction side shell wall is then removed from the flexible mold and is joined to its counterpart pressure side shell wall (similarly formed in a separate process) and with the separately formed ceramic core to form the ceramic casting vessel 34, as shown in FIG. 2G. Co-pending International Patent Application PCT/US2009/58220 describes techniques that may be used for forming interlocking mechanical geometries into each shell half to facilitate the joining of the separately cast sections. Alternatively, or in combination with a mechanical interlock, a ceramic adhesive and/or sintering of the adjoining surfaces may be used to form the joints. The casting vessel is then used to receive molten alloy 46 according to processes known in the art as shown in FIG. 2H to form the cast alloy gas turbine blade 48 of FIG. 2I.

The above-described waxless precision casting process produces a ceramic casting vessel for a gas turbine or other component without the need for manufacturing a wax pattern tool, and it therefore eliminates all of the cost and problems associated with wax injection.

Precision Cast Shell

Prior art lost-wax investment casting processes utilize a dipping process to form the ceramic shell around a wax pattern containing a ceramic core. The dipping process requires repeated dipping of the wax pattern into ceramic slurry, then drying of the thin layer of the slurry that is retained on the dipped structure. This process may take several days to complete. The interior surface of the dried slurry shell replicates the form of the wax pattern, and on its exterior surface it creates an amorphous blob shape.

Unlike the prior art process, the precision cast shell created for the waxless casting process described herein allows for the fabrication of engineered shapes/features on either or both of the interior and exterior

surfaces of the shell. It also allows the thickness of the shell to be controlled and varied along its length. For example, FIG. 3 illustrates side-by-side portions of two different ceramic casting vessels 34a, 34b - the suction side shell wall 50 of a first gas turbine blade vessel and the pressure side shell wall 52 of a second gas turbine blade. The two shell sections may each have regions of greater or lesser wall thicknesses, such as may be useful for heat transfer considerations or stress management. Furthermore, precision engineered features 54 may be formed on any surface, such as the cooperating pin and slot features shown in FIG. 3 which provide a mechanical interlock between the two adjacent ceramic casting vessels, such as may be advantageous to provide mechanical support there between during a multi-component casting operation. The exterior surface may include a robotic handling connection for automated casting applications, or the shell may have a notch or other engineered weakness areas which facilitate the breaking away of the vessel for removal of the cast alloy part (not shown).

Advantageously, the engineered shapes/features may have any desired degree of precision, including simple structures as illustrated in FIG. 3 which may be formed in the master tool using standard machining operations, or more complex features that may be located into the master tool via a precision formed insert. The casting process used for forming the shell herein allows for vacuum injection of the ceramic molding material and vibration of the flexible mold to ensure that no air is entrained in the cast part, as described above, thereby facilitating the fabrication of such features. Prior art dipping processes are more prone to entraining air within a precision feature and are not capable of retaining the fidelity of an engineered surface. The shell of the present invention may also be formed to include features 56 which increase its strength in particular areas, such as by adding additional material thickness or a honeycomb shape at desired locations or by embedding a reinforcing material such as an oxide-based woven ceramic fabric or alloy mesh or foil during the casting of the shell.

Through wall cooling holes in gas turbine blades are typically formed by a material removal process such as EDM or drilling after the alloy blade is cast without such holes. The present process allows for such holes to be cast directly into the alloy part by including the shape of such holes as

protrusions extending from either the ceramic core or the shell or both. The geometry and/or path of such holes is not restricted to a circular cross-section or a linear form, since the shape can be formed into the master mold via a Tomo process. Advantageously, the ceramic casting material disclosed in the above-cited International Patent Application PCT/US2009/58220 exhibits enough green body strength to allow such features to be extracted from a flexible mold and to be handled during the assembly of the ceramic casting vessel. A protrusion 58 extending from a first of the shell or core (illustrated as extending from the core in FIG. 2G) may be designed to abut or to be inserted into an indentation 60 formed in a second of the shell or core (illustrated as formed into the shell in FIG. 2G) to provide mechanical support for the protrusion during the subsequent molten alloy injection process. The resultant cooling hole 62 is illustrated in FIG. 2I.

FIG. 10 illustrates a ceramic casting vessel 92 including a precision formed insert 94 defining the geometry of a non-linear cooling channel to be formed in a hollow gas turbine airfoil component. Advantageously, the insert includes a portion 96 running generally parallel to a surface of the component, thereby increasing the effectiveness of the cooling channel. This type of geometry is not obtainable with standard post-casting machining processes. Each insert may define a single cooling channel, or alternatively, a plurality of cooling channels may be defined by an insert 98 formed with a comb design, as illustrated in FIG. 11. Such inserts may be formed to be integral to the core or the shell section, and/or may have an end that fits into a mating groove in a core or shell section. The insert may also be made of a higher strength leachable material, such as silica, in a separate process and incorporated into the casting vessel accordingly.

Assembly of the Ceramic Casting Vessel

Prior art lost-wax investment casting processes create an opportunity for misalignment between the ceramic core and the wax pattern tool during the wax injection process, which is particularly problematic in the trailing edge core print area of a turbine blade where the cross-section of the airfoil is particularly thin and the cooling passage geometry defined by the core is complex. Prior art processes may utilize alloy alignment pins projecting from

the wax pattern tool to bear against the core to ensure proper positioning. Unfortunately, such hard pins sometimes damage the fragile ceramic core if there is any misalignment during assembly of the wax pattern tooling, and damage to the core or misalignment of the core within the wax pattern tooling can only be detected with a non-destructive test such as X-ray, or when a defective cast alloy part is removed from the casting vessel.

The waxless precision casting process described herein allows for precise alignment of the core within the shell without the use of such pins, and it also allows for a visual confirmation of that alignment prior to molten alloy injection. FIG. 4 illustrates a three-piece ceramic casting vessel 34 produced as described above during assembly of the three pieces to form the ceramic casting vessel. A bottom half 64 of the shell of the ceramic casting vessel may be conveniently laid on a work area and the ceramic core section 10 is then laid into that shell half. Cooperating precision mechanical alignment features 66 formed in the two pieces allow for the core to be located at the precise location desired, with a literal snap fit being possible if desired. A visual inspection can then be conducted to confirm that the core is properly located prior to lowering the top half section 68 of the shell onto the assembled bottom half shell and core assembly. Should any misalignment be detected, there is opportunity to reshape the parts, such as by removing some material with a simple filing process. Once proper alignment is confirmed, the top shell section may be positioned onto the bottom shell/core assembly and received into precision alignment features formed into the bottom shell section and/or core, perhaps with a snap fit, to ensure proper alignment of all three sections. This procedure eliminates the need for a separate X-ray inspection step and it greatly reduces or eliminates the opportunity for misaligned or damaged cores and any consequentially defective cast parts.

The present invention also affords the opportunity to fire the various casting vessel sections together or separately. For example, the three vessel sections shown in FIG. 4 may be assembled in their green state, or one or more of the sections may be partially or fully sintered prior to assembly. Any combination of green state, partially sintered or fully fired for each of the sections may be used as selected by the designer to control shrinkage and co-sintering of the adjoining surfaces.

It will be appreciated that the joining of the two shell sections of FIG. 4 produces a part line between the shell halves that may allow for the infiltration of some molten alloy during the alloy casting step. Any such part line may be removed from the cast alloy part by simple grinding or machining operation. Alternatively, the part line may be reduced or eliminated by tightening the joint between the shell halves, such as by closely controlling the geometry of the adjoining surfaces, creating a labyrinth type joint that tends to block the flow of the molten alloy, and/or applying a ceramic adhesive between the adjoined surfaces and/or sintering them together to form a seamless joint. It is also possible to apply a ceramic coating to fill the joint after the two shell halves are joined, such as via a dipping process.

Further advantages of waxless casting

A further advantage of the precision waxless casting process described herein is the ability to use the same casting material for all portions of a ceramic casting vessel. Prior art lost-wax investment casting processes use one type of ceramic material for casting the ceramic core and a different type of ceramic material for dip-forming the ceramic shell, since the dipping process necessitates special material properties. The use of two different materials presents a potential for thermal expansion or sintering shrinkage mismatches. The dip-formed material may also contain less porosity than is desirable and is achieved for the core material. In contrast, the present invention permits the use of the same ceramic casting material for the entire ceramic casting vessel. Alternatively, engineered material properties can be achieved in the shell material or any section of the ceramic casting vessel, such as a specifically targeted porosity.

Yet another advantage of the waxless casting process is the avoidance of exposure of the ceramic casting vessel material to molten wax. Removal of the wax from the ceramic casting vessel is a messy and time consuming process. For a hollow component, the ceramic core material is purposefully porous, and it is necessary to seal the surface of the core prior to wax injection in order to keep the wax from infiltrating the pores of the ceramic core material. If wax penetrates the pores of the ceramic material, it is very difficult to remove and causes defects in the subsequently cast alloy part as

the wax volatilizes during molten alloy injection and creates voids in the alloy. To avoid this problem, it is necessary to seal the ceramic core surface with a sealant material which keeps the wax out of the material pores but is, itself, easily removed from the ceramic core material during the wax removal step. The waxless process described herein completely eliminates any exposure of the core material to wax and it eliminates the need for an extra step to seal the core material pores.

It is also possible with the waxless precision casting process to embed sensors or other type of active device 70 into the shell during casting. Such devices may be used to monitor or to control the subsequent alloy casting process.

Engineered surface features

The present waxless precision casting process may be used to imparting a desired engineered surface texture into a cast alloy part. Prior art wax pattern tools are typically formed of hard steel having smooth surfaces which produce smooth surfaces on the cast part. The cast alloy parts are then subjected to a surface roughening process, such as grit blasting or shot peening, prior to the application of a protective coating. This creates a degree of variation in the surface texture of different parts and of different areas of a single part because each part is individually roughened, and such processes are inherently imprecise. Rather than requiring post-casting processing of the part, the present process allows the part to be cast directly with a desired surface finish. In one embodiment, the master tooling of FIG. 2E1 or 2E2 may be grit blasted, shot peened or otherwise roughened prior to the casting of the flexible mold. The roughness imparted to the master mold surface will be replicated into the flexible mold, then into the surface of the shell, and ultimately into the cast part. The master tooling may be used to produce multiple duplicate copies of the flexible mold, and every part produced from the master mold and derived flexible molds will have an identical surface topography. In another embodiment, the topography produced by the grit blasting or shot peening of the master mold may not be adequate, and a more precise form of surface finish may be desired, at least on selected surfaces of the part. In this embodiment, a precision engineered surface topography may

be formed into the master tool or into an insert to the master tool. That engineered surface topography is then replicated through the investment casting process onto the cast alloy part surface.

The flexible molds of FIG. 2F may be derived directly from a Tomo process master mold, as described in the cited United States patents 7,141,812 and 7,410,606 and 7,411,204, or from a low cost aluminum mold having a precision insert formed via a Tomo process. Alternatively, a Tomo process mold or other precision master mold may be used to form one or more intermediate molds (not shown), with the intermediate mold(s) being subjected to a further process step which modifies and further enhances the surface topography. In one embodiment an alloy foil master Tomo process mold is used to cast a first flexible mold, and the first flexible mold is used to cast a fibrous material intermediate mold. The intermediate mold is then grit blasted to expose some of the fibers at the surface of the mold. A second flexible mold is then cast into the intermediate mold, and the second flexible mold will replicate the shape of the exposed fibers as part of the surface topography. The second flexible mold is then used to cast the shell in FIG. 2F.

In its simplest form, the flexible tooling is used to generate robust features in the surface of the ceramic shell. Typically, these would be relatively low angled and of shallow profile with the objective of creating high angle steps at the edge to create an interlock geometry and to increase the surface area of the interface with an overlying coating. A hexagonal type structure or honeycomb structure may be used. FIG. 5 shows one such surface 72. Such surfaces produce translatable honeycomb-like surfaces in investment castings resulting in a periodically rough surface (in the macro range) that creates a high degree of interlock and increased surface area for bond integrity with an overlying coating layer. An additional benefit may also be gained from increased intermittent coating thickness across the surface.

Additional surface engineering can result in even greater surface area increase and interlock, such as seen in FIG. 6, where the edges of a hex shape form are rounded out to form gear-cog type layers 74. Typical surface feature depths have been produced and shown to be effective at both 0.38 mm and 0.66 mm, but these depths do not represent optimization and are not

meant to be limiting. In areas of high surface angularity (e.g. leading edge or trailing edge sections of an airfoil or the airfoil/platform intersection), pattern protrusions from the surface may be beneficial. Such protrusions can be produced from second generation flexible molds (i.e. flexible mold replication from flexible mold masters). FIG. 7 shows an example of a protruded surface pattern 76 produced by such a mold technique. Protruding molds can be engineered to produce undercuts in the surface, thereby increasing the degree of mechanical interlock with the coating. This is particularly useful in highly stressed areas of coatings. It is noted that undercuts can also be generated in depressed surface features, but effective coating becomes more challenging due to the significant effect of shadowing during the coating step. Protruding surface patterns have the additional benefit of producing a larger aggregate coating thickness when considering the peak height as the nominal coating thickness.

The master tooling can be further modified by non-Tomo surface modifying techniques such as grit blasting or sanding, producing laser-derived micro pot marks on the surface, or the addition of a second phase material bonded to the surface of the master tool. Such materials may include, without limitation, silicon carbide particles or chopped fibers. The surface modifying technique or the second phase material produces a random surface array on the surface of the tool which can be used to define the surface of the flexible mold tool and potentially be duplicated from a second generation flexible mold tool. FIGs. 8A - 8C show surfaces 78, 80, 82 produced from a master tool that was progressively modified with varying degrees of hybridized surfaces to produce unique micro surface features. In this case, the master tool was progressively grit blasted, and the basic Tomo process shape is progressively eroded, resulting in an ever more rounded structure but still retaining the basic shape of the Tomo process feature. This hybridization, combined with the capability of the Tomo process to produce either recessed or protruding engineered surfaces, shows the substantial flexibility of the process to produce a wide variety of engineered surfaces in an as-cast part. Advantageously, the present process allows for the duplication of a grit blasted surface without the need for additional actual grit blasting, thus ensuring exact part to part replication. The process effectively becomes

insensitive to surface modification process variation once the master tool has been produced because all resulting surfaces that are generated from the master tool are identical.

As discussed above, the improved ceramic material described in pending International Patent Application PCT/US2009/58220 provides for post-casting thermal forming. This feature may advantageously be applied to achieve unique surface topographies by forming the insert in one shape, such as generally flat, and then thermally forming it to a second shape, such as a curved shape. One will appreciate that the spacing between any protruding features of a flat surface will be pushed together (tightened) when that surface is curved inwardly on itself to form a concave shape.

FIG. 9 illustrates a ceramic casting vessel 84 formed in accordance with an embodiment of the invention to include a relatively thin outer shell 86 that will be subsequently reinforced with a secondary shell structure (not shown). The secondary shell structure may be a pre-formed structure, with the outer surface of the shell and an inner surface of the pre-formed structure being cooperatively shaped. Alternatively, the secondary shell structure may be formed directly onto the outer shell using a dipping process as is known in the art. The outer shell may include one or more handling structures 88 that may be used to support the vessel during the dipping process. It may also include one or more dipping structures 90 that advantageously impact the flow of the ceramic slurry over the surface and the retention of the slurry on the structure during the dipping process.

Business model for the casting industry

The above-described waxless precision casting process facilitates a new business model for the casting industry. The prior art business model utilizes a single set of very expensive, long lead time, rugged master tooling to produce multiple disposable ceramic casting vessels (and subsequently cast alloy parts) with rapid injection and curing times. In contrast, the new regiment disclosed herein utilizes a less expensive, more rapidly produced, less rugged master tool and an intermediate flexible mold derived from the master tool to produce the ceramic casting vessel with much slower injection and curing times. Thus, the new casting regiment can be advantageously

applied for rapid prototyping and development testing applications because it enables the creation of a first-of-a-kind ceramic casting vessel (and subsequently produced cast alloy part) much faster and cheaper than with the prior art methods. Furthermore, the new regiment may be applied effectively in high volume production applications because multiple identical intermediate flexible molds may be cast from a single master tool, thereby allowing multiple identical ceramic casting vessels (and subsequently cast alloy parts) to be produced in parallel to match or exceed the production capability of the prior art methods while still maintaining a significant cost advantage over the prior art. Furthermore, each flexible mold may be reused multiple times to produce multiple identical ceramic casting vessel sections. The time and cost savings of the present regiment include not only the reduced cost and effort of producing the master tool and the elimination of all of the wax injection equipment and tooling, but also the elimination of certain post-alloy casting steps that are necessary in the prior art to produce certain design features, such as trailing edge cooling holes or surface roughness, since such features can be cast directly into the alloy part using the new regiment disclosed herein whereas they require post-casting processing in the prior art. The present regiment provides these cost and production advantages while at the same time enabling the casting of design features that heretofore have not been within the capability of the prior art techniques. thereby for the first time allowing component designers to produce the hardware features that are necessary to achieve next generation gas turbine design goals.

While various embodiments of the present invention have been shown and described herein, it will be obvious that such embodiments are provided by way of example only. Numerous variations, changes and substitutions may be made without departing from the invention herein.

CLAIMS

The invention claimed is:

1. A casting process for an alloy component comprising:
 - casting a ceramic core into a flexible core mold, the flexible core mold defining a geometry of an interior passageway of the alloy component and a first cooperating alignment feature;
 - casting a ceramic shell in at least two sections into respective flexible shell molds, the flexible shell molds collectively defining an external geometry of the alloy component and a second cooperating alignment feature;
 - forming a ceramic casting vessel by assembling the ceramic core within the ceramic shell sections while aligning the first and second cooperating alignment features;
 - casting alloy into the ceramic casting vessel; and
 - removing the ceramic casting vessel to reveal the alloy component having the interior passageway.

2. The casting process of claim 1, further comprising casting any one of the flexible core mold or flexible shell molds with a process comprising:
 - forming a master mold to define a first region comprising relatively low precision features;
 - incorporating a mold insert into the master mold to define a second region comprising relatively high precision features having dimensional tolerances smaller than those of the relatively low precision features; and
 - casting the any one of the flexible molds into the joined master mold and mold insert.

3. The casting process of claim 1, wherein at least one of the casting steps comprises vibrating the respective flexible mold while introducing a ceramic material slurry into the respective flexible mold, the vibrating step effective to displace air entrapped by a protruding surface of the respective flexible mold with the slurry.

4. The casting process of claim 1, further comprising using a common composition of ceramic material for casting the ceramic core and for casting the ceramic shell sections.

5. The casting process of claim 1, further comprising positioning an active device into at least one of the flexible core molds, flexible shell molds or ceramic shell sections for operation during a subsequent casting step.

6. The casting process of claim 1, further comprising forming the cooperating alignment features along a part line between the shell sections.

7. The casting process of claim 1, further comprising applying an adhesive between the shell sections to at least partially seal a part line there between.

8. The casting process of claim 1, further comprising:
disposing a first of the shell sections on a surface;
assembling the ceramic core onto the first of the shell sections;
visually confirming proper alignment of the ceramic core relative to the first of the shell sections; then
assembling a second of the shell sections onto the ceramic core and first of the shell sections; and
visually confirming proper alignment of the second of the shell sections relative to the first of the shell sections or to the ceramic core.

9. The casting process of claim 1, further comprising firing the ceramic core and the shell sections to different degrees of a fully sintered condition to control shrinkage and co-sintering of adjoining surfaces prior to a final sintering step, prior to the step of casting alloy into the ceramic casting vessel.

10. The casting process of claim 1, further comprising casting at least one of the flexible shell molds with a process comprising:
forming a master mold;
texturing a surface of the master mold to achieve a desired topography;
and

casting the at least one of the flexible shell molds into the master mold to replicate the desired topography;

whereby the desired topography is then replicated through the respective ceramic shell section to a surface of the alloy component.

11. The casting process of claim 10, wherein the step of texturing comprises subjecting the master mold surface to one of grit blasting, sanding, laser-derived pot marking, or additional of a second phase material.

12. The casting process of claim 1, further comprising casting at least one of the flexible shell molds with a process comprising:

forming a master mold;

forming an intermediate mold comprising a fibrous material;

grit blasting a surface of the intermediate mold to achieve a desired topography; and

casting the at least one of the flexible shell molds into the intermediate mold to replicate the desired topography;

whereby the desired topography is then replicated through the respective ceramic shell section to a surface of the alloy component.

13. The casting process of claim 1, further comprising subjecting at least one of the ceramic core or ceramic shell sections to a thermal reshaping process after it has reached a green body state but before it is fully fired.

14. The casting process of claim 1, further comprising forming at least one of the flexible shell molds to define an engineered surface feature on an exterior surface of the respective ceramic shell section.

15. The casting process of claim 1, further comprising during at least one of the casting steps, embedding a reinforcing material into at least one of the ceramic core and ceramic shell sections.

16. The casting process of claim 1, further comprising forming a tab on at least one of the ceramic shell sections and subjecting the tab to a thermal reshaping process after it has reached a green body state but before it is fully fired.

17. The casting process of claim 1, further comprising forming at least one of the ceramic core and the ceramic shell to comprise a portion extending there between when assembled to form the ceramic casting vessel to define a geometry of a cooling passage through the alloy component.

18. The casting process of claim 1, further comprising forming an insert to be disposed between the ceramic core and the ceramic shell when the ceramic casting vessel is assembled to define a geometry of a cooling passage through the alloy component.

19. The casting process of claim 18, further comprising forming the insert to comprises a nonlinear portion defining a nonlinear cooling passage.

20. The casting process of claim 18, further comprising forming the insert to define a plurality of cooling passages.

21. A casting process for an alloy component comprising:
forming master tooling defining each of a plurality of sections of a ceramic casting vessel shape, the sections each comprising at least one alignment feature shaped for cooperative alignment with an alignment feature of another of the sections for assembly of the ceramic casting vessel shape;
casting a plurality of identical sets of flexible molds in the master tooling, each flexible mold replicating a respective section of the ceramic casting vessel shape, the master tooling being reused for casting multiple identical sets of flexible molds;
casting a plurality of sets of identical ceramic casting vessel sections in the plurality of sets of identical flexible molds;
assembling a plurality of identical ceramic casting vessels by assembling the respective plurality of sets of ceramic casting vessel sections while aligning the respective cooperative alignment features;
casting the plurality of identical alloy components in the plurality of identical ceramic casting vessels; and
removing the ceramic casting vessels to reveal the plurality of identical alloy components.

22. The casting process of claim 21, further comprising:
forming the master tooling to comprise a first region comprising relatively low precision features;
incorporating a mold insert into the master tooling to define a second region comprising relatively high precision features having dimensional tolerances smaller than those of the relatively low precision features.
23. The casting process of claim 21, wherein the step of casting a plurality of sets of identical ceramic casting vessel sections comprises vibrating the respective flexible mold while introducing a ceramic material slurry into the respective flexible mold, the vibrating step effective to displace air entrapped by a protruding surface of the respective flexible mold with the slurry.
24. The casting process of claim 21, further comprising positioning an active device into at least one of the flexible molds or ceramic casting vessel sections for operation during a subsequent casting step.
25. The casting process of claim 21, further comprising firing the ceramic shell sections to respective different degrees of a fully sintered condition to control shrinkage and co-sintering of adjoining surfaces prior to a final sintering step and prior to the step of casting the plurality of identical alloy components.
26. The casting process of claim 21, further comprising:
texturing a surface of the master tooling to achieve a desired topography; and
replicating the desired topography into the plurality of identical alloy components through the respective flexible molds and ceramic casting vessels.
27. The casting process of claim 26, wherein the step of texturing comprises subjecting the master tooling surface to one of grit blasting, sanding, laser-derived pot marking, or additional of a second phase material.

28. The casting process of claim 21, further comprising forming the master tooling to define shapes of a core and at least two shell sections including respective alignment features which when assembled together, with respective alignment features in cooperative alignment, form the ceramic casting vessel shape.

29. The casting process of claim 21, further comprising forming a tab on at least one of the ceramic casting vessel sections and subjecting the tab to a thermal reshaping process after it has reached a green body state but before it is fully fired.

30. A casting process for an alloy component comprising:
defining a ceramic casting vessel in a digital model;
dividing the digital model into a plurality of vessel sections comprising cooperating alignment features;
fabricating master tooling representing each of the vessel sections;
casting flexible molds for each of the vessel sections in the master tooling;
casting ceramic casting vessel sections in the flexible molds;
assembling the ceramic casting vessel sections into a ceramic casting vessel while aligning the cooperating alignment features;
casting an alloy component in the ceramic casting vessel; and
removing the ceramic casting vessel to reveal the alloy component.

31. The casting process of claim 30, further comprising:
using the master tooling to cast a plurality of sets of identical flexible molds for each of the respective vessel sections; and
using the plurality of sets of identical flexible molds to produce in parallel a respective plurality of alloy components in accordance with the steps of claim 28.

32. The casting process of claim 30, further comprising:
forming the master tooling to define a first region comprising relatively low precision features;

incorporating a mold insert into the master mold to define a second region comprising relatively high precision features having dimensional tolerances smaller than those of the relatively low precision features.

33. The casting process of claim 30, wherein the step of casting ceramic casting vessel sections comprises vibrating the respective flexible mold while introducing a ceramic material slurry into the respective flexible mold, the vibrating step effective to displace air entrapped by a protruding surface of the respective flexible mold with the slurry.

34. The casting process of claim 30, further comprising positioning an active device into at least one of the flexible molds or ceramic casting vessel sections for operation during a subsequent casting step.

35. The casting process of claim 30, further comprising firing the ceramic shell sections to respective different degrees of a fully sintered condition to control shrinkage and co-sintering of adjoining surfaces prior to a final sintering step and prior to the step of casting the alloy component.

36. The casting process of claim 30, further comprising:
texturing a surface of the master tooling to achieve a desired topography; and
replicating the desired topography into the alloy component through the respective flexible mold and ceramic casting vessel.

37. The casting process of claim 30, wherein the step of texturing comprises subjecting the master tooling surface to one of grit blasting, sanding, laser-derived pot marking, or additional of a second phase material.

38. The casting process of claim 30, further comprising:
forming the master tooling to define shapes of a core and at least two shell sections including respective alignment features which when assembled together, with the respective alignment features in cooperative alignment, form the ceramic casting vessel shape.

39. The casting process of claim 30, further comprising forming a tab on at least one of the ceramic casting vessel sections and subjecting the tab to a thermal reshaping process after it has reached a green body state but before it is fully fired.

40. The casting process of claim 30, further comprising:
forming an intermediate mold comprising a fibrous material from the master tooling;
grit blasting a surface of the intermediate mold to achieve a desired topography; and
casting at least one of the flexible molds into the intermediate mold to replicate the desired topography;
whereby the desired topography is then replicated into a surface of the alloy component.

41. The casting process of claim 30, further comprising subjecting at least one of the ceramic casting vessel sections to a thermal reshaping process after it has reached a green body state but before it is fully fired.

42. The casting process of claim 30, further comprising forming the master tooling to define an engineered feature on an exterior surface of the ceramic casting vessel.

43. The casting process of claim 30, further comprising embedding a reinforcing material into at least one of the ceramic casting vessel sections.

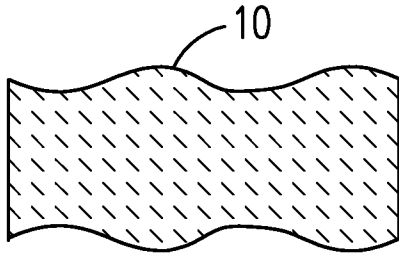

FIG. 1A

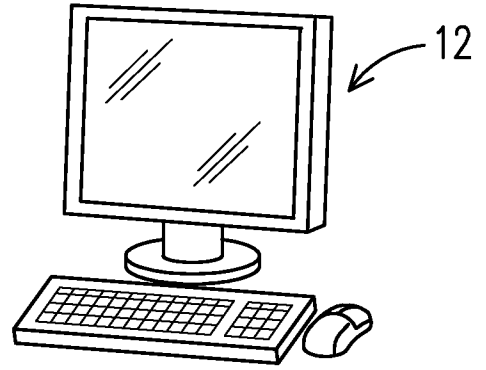

FIG. 1B

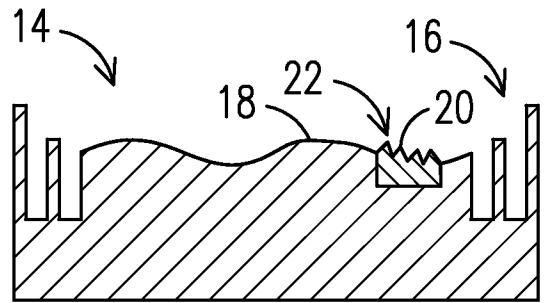
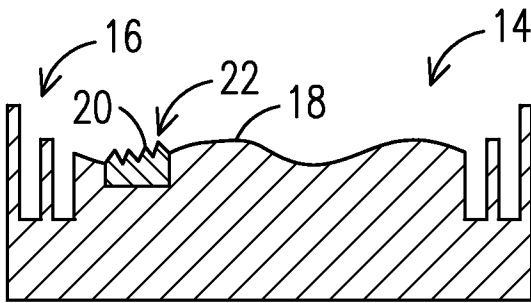

FIG. 1C

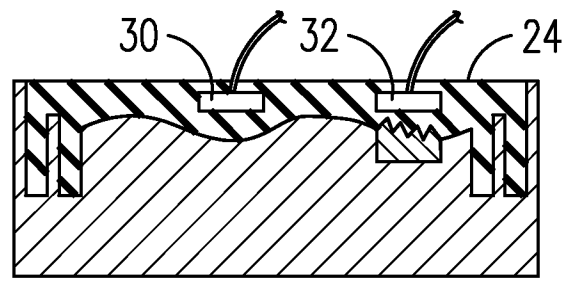
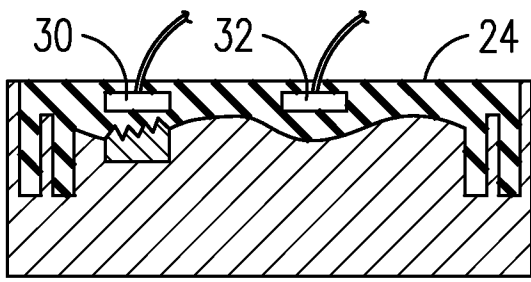

FIG. 1D

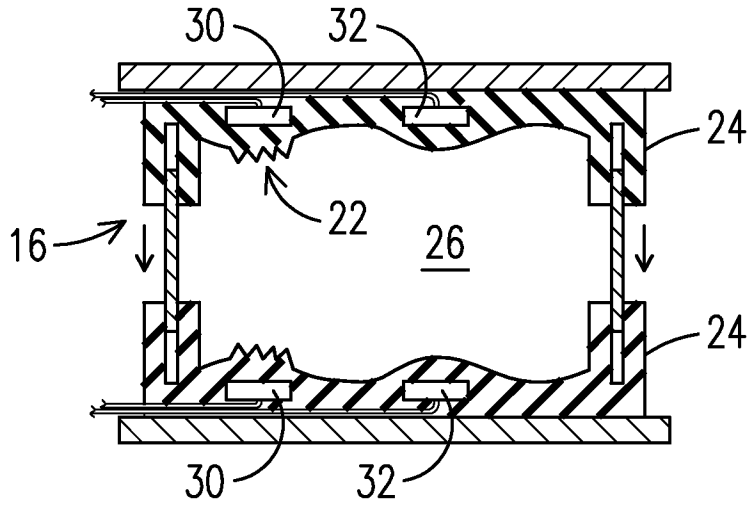

FIG. 1E

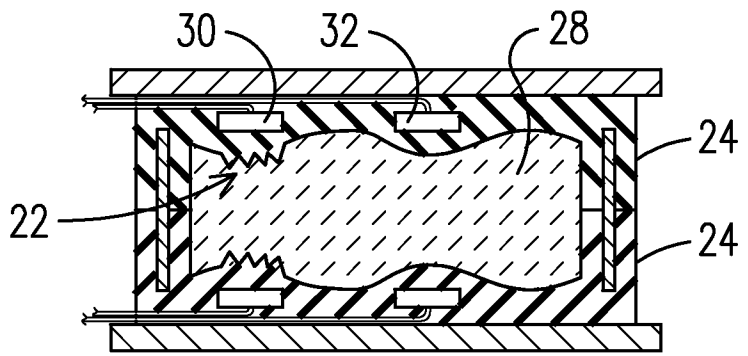

FIG. 1F

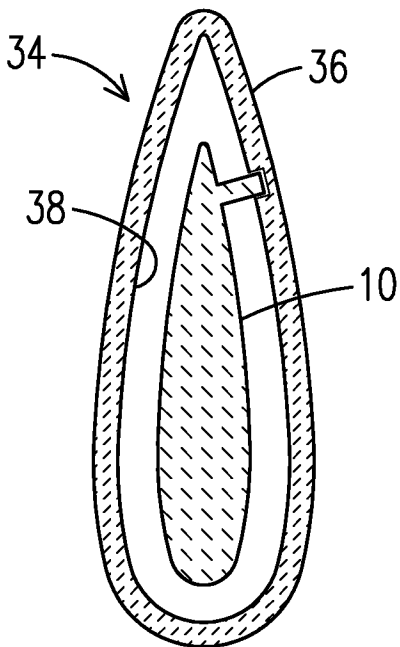

FIG. 2A

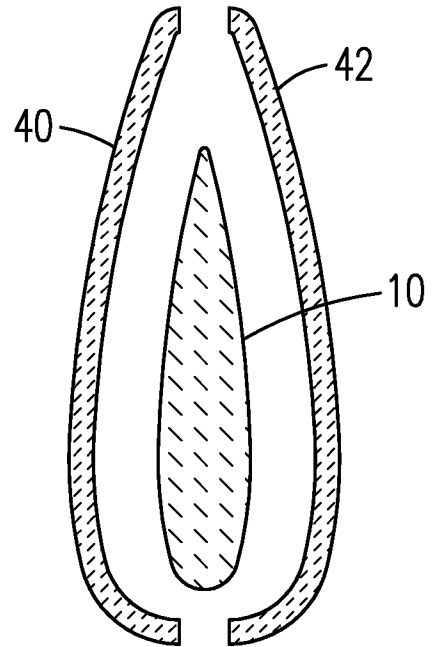

FIG. 2B

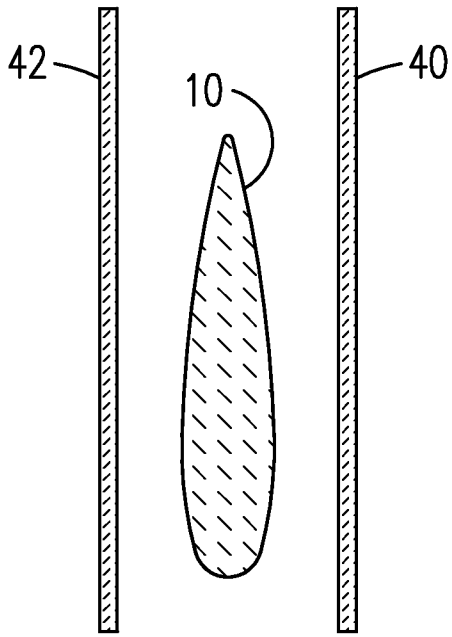

FIG. 2C

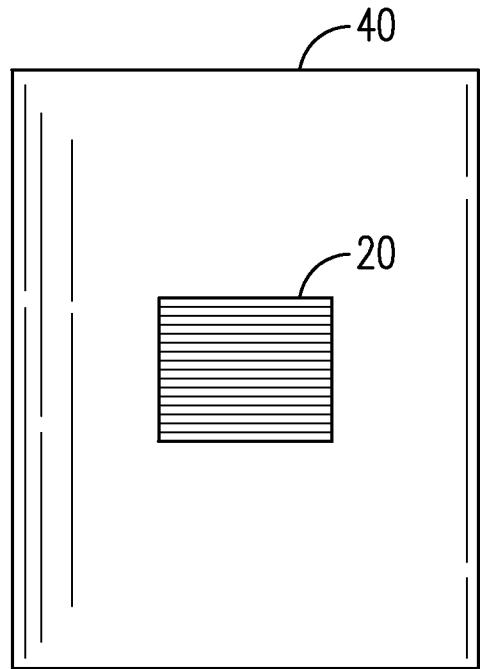

FIG. 2D1

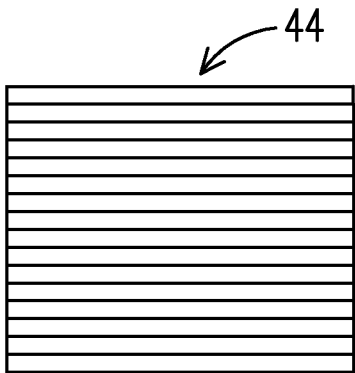
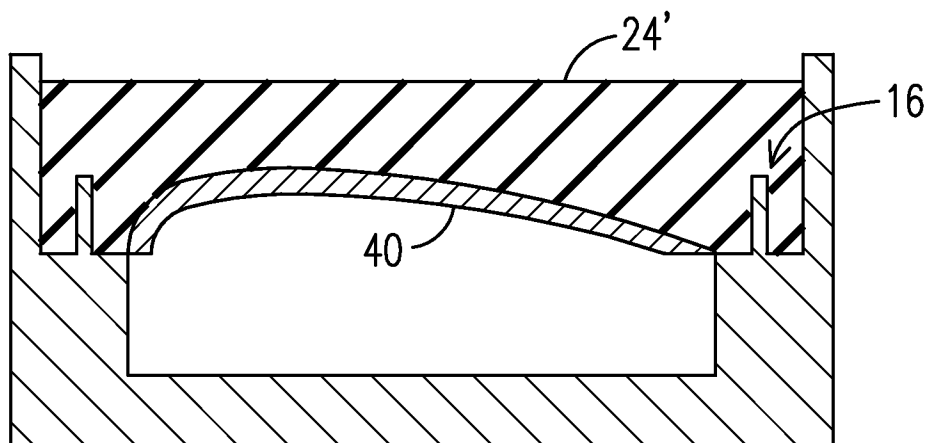

FIG. 2D2

FIG. 2E1



4/9

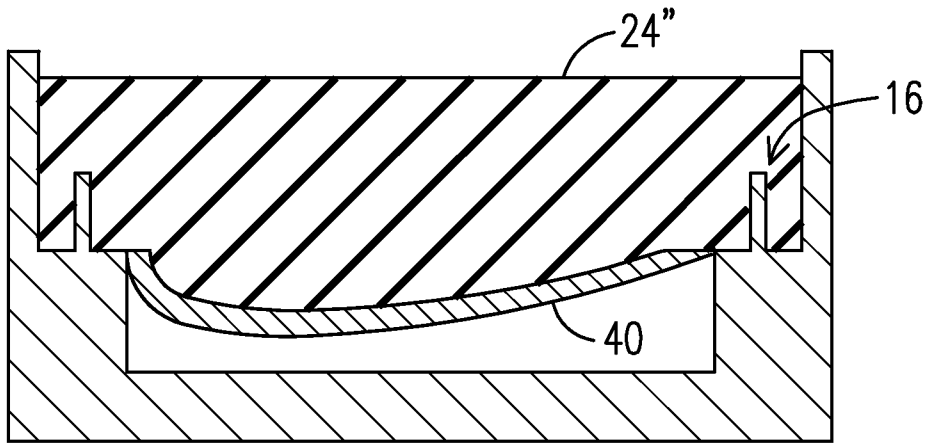

FIG. 2E2

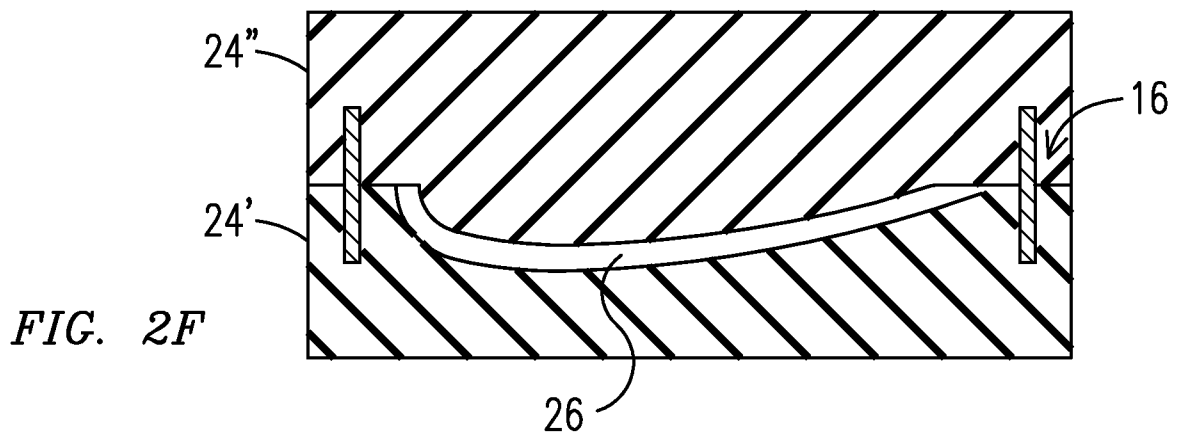

FIG. 2F

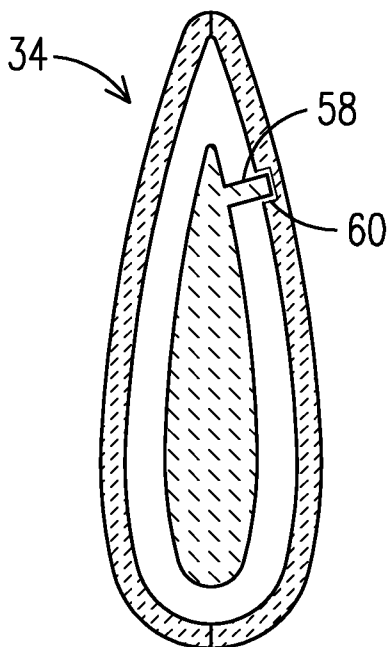

FIG. 2G

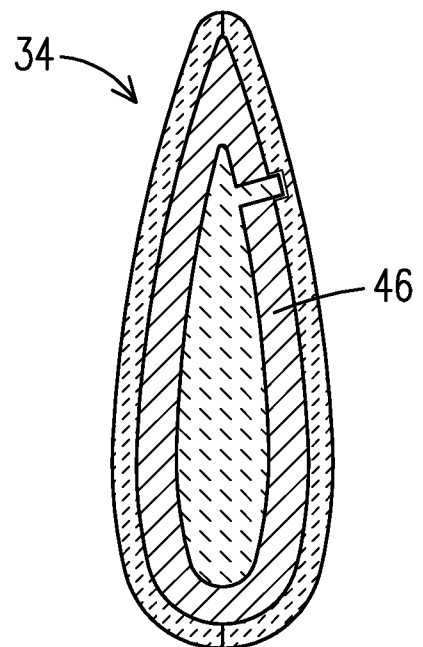

FIG. 2H

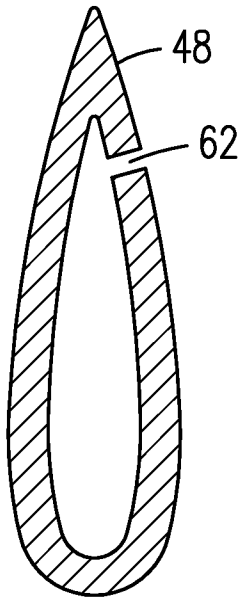

FIG. 21

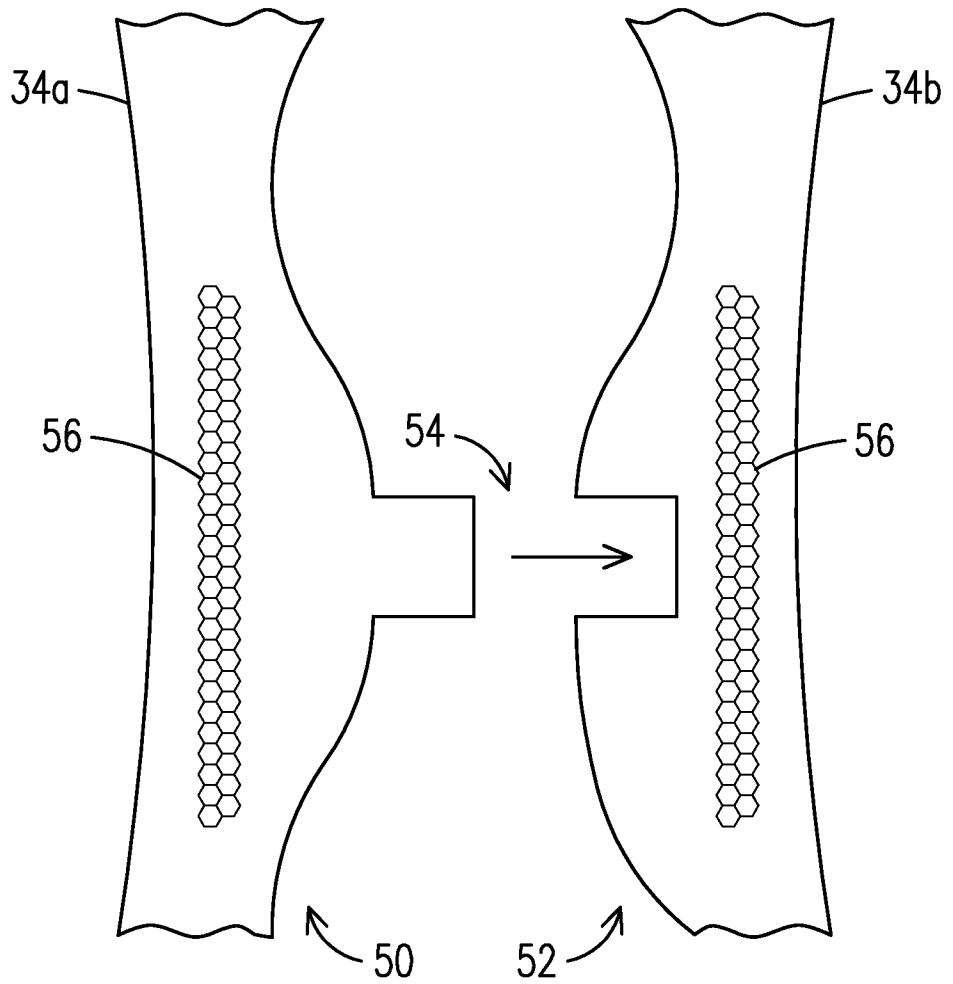
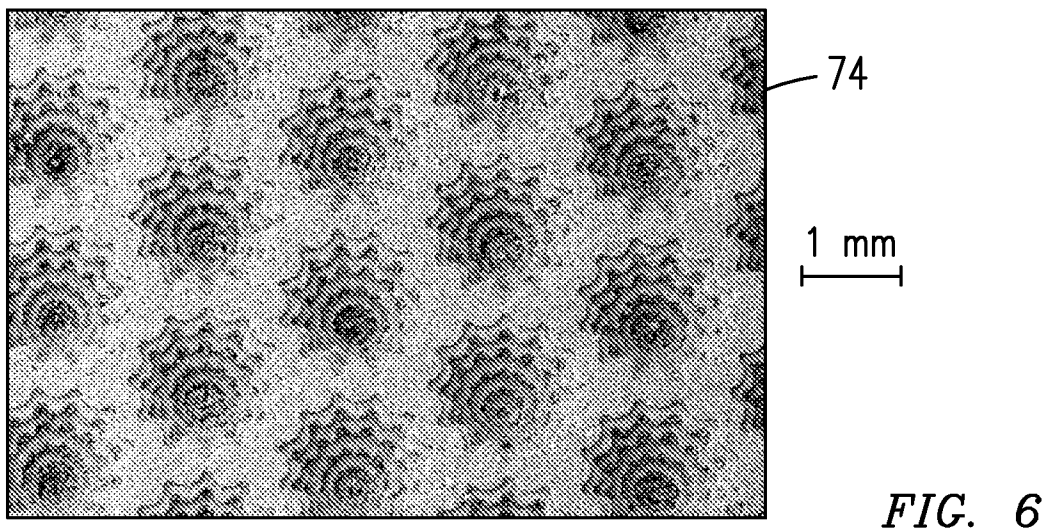
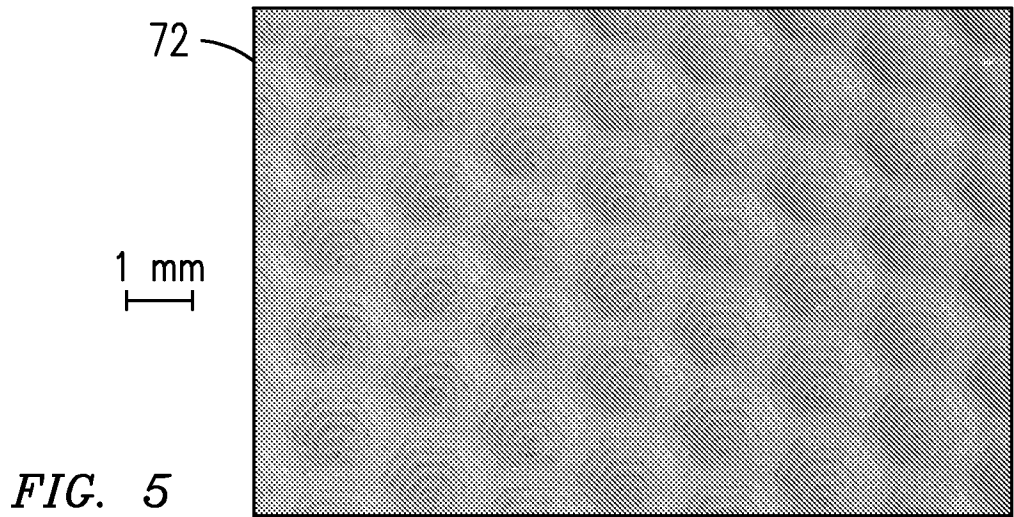
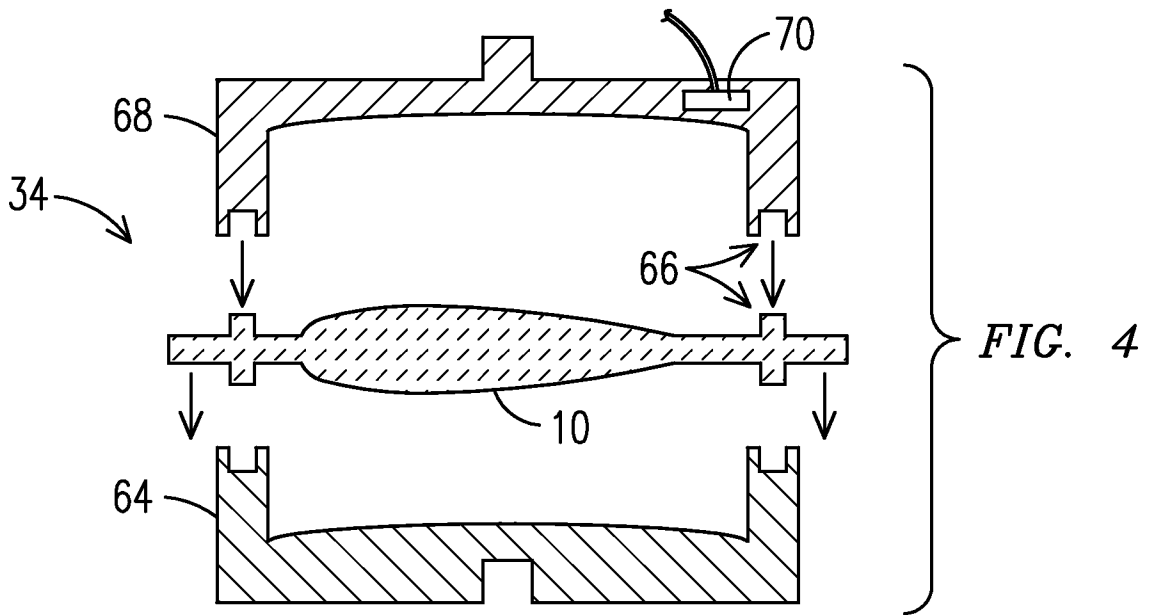

FIG. 3



7/9

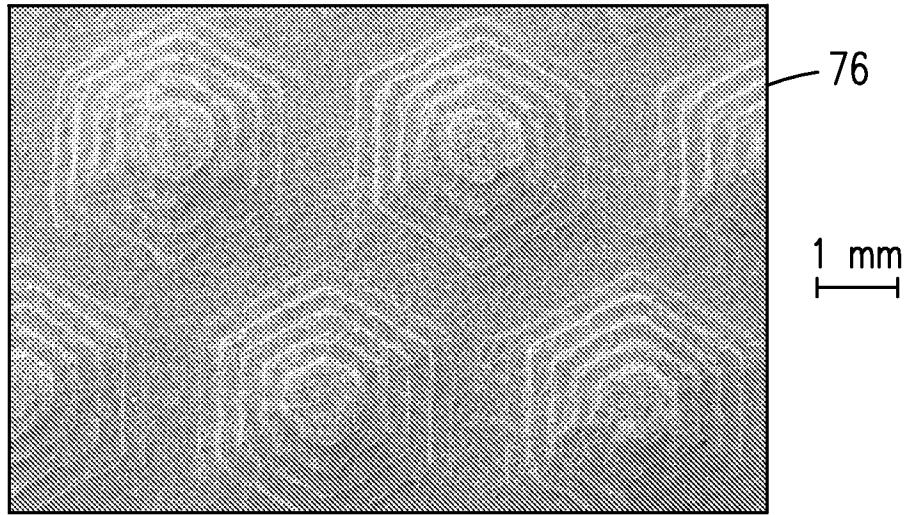

FIG. 7

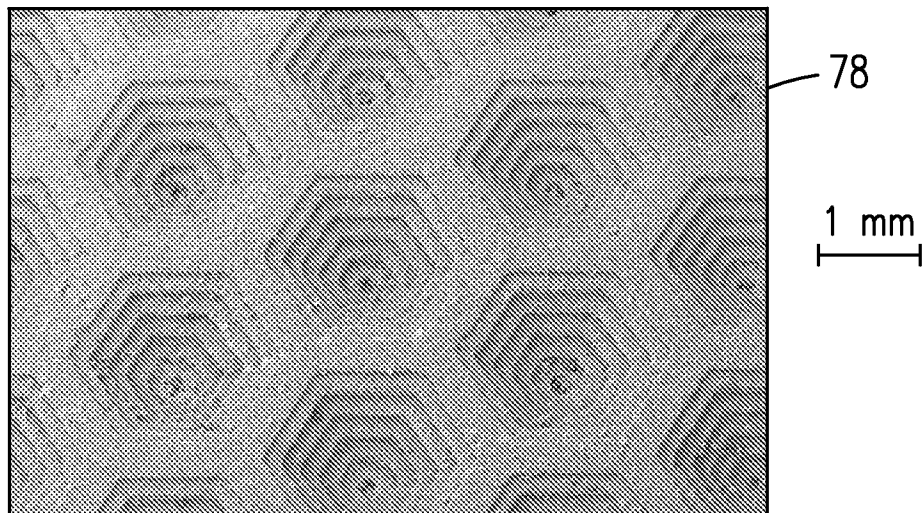

FIG. 8A

8/9

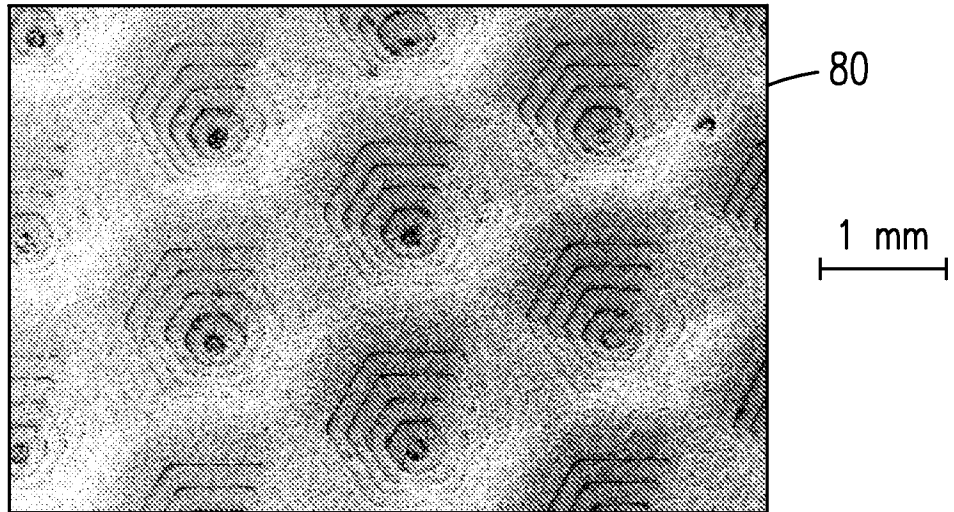

FIG. 8B



FIG. 8C

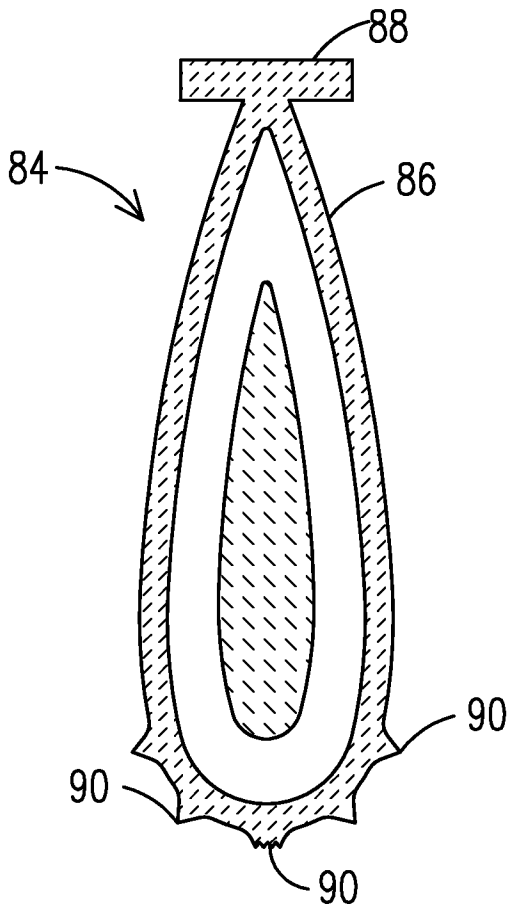

FIG. 9

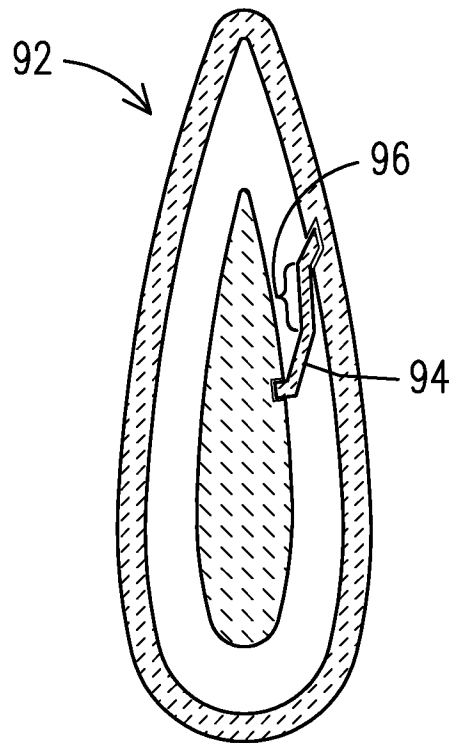

FIG. 10

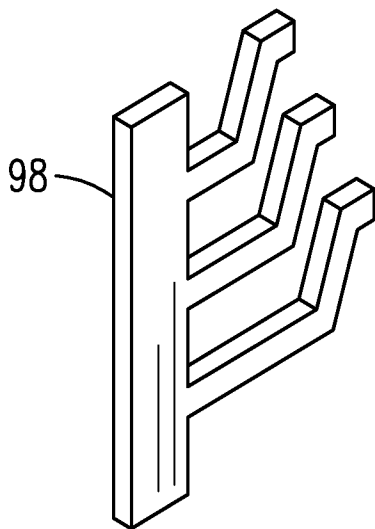

FIG. 11