

J. MILLER & S. HEAD.
Machines for Sawing Staves.

No. 196,691.

Patented Oct. 30, 1877.

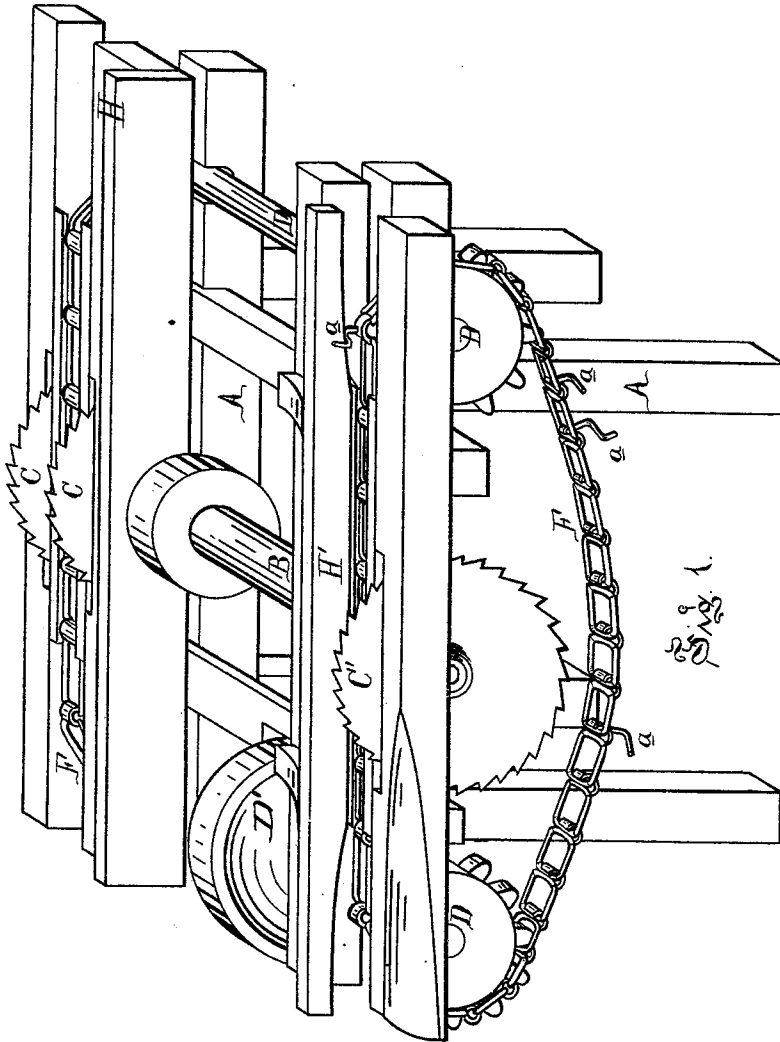

Witness:
A. H. Cull
Chas. J. Hunt

Inventors:
J. Miller
S. Head
By atty
Thos. S. Sprague

J. MILLER & S. HEAD.
Machines for Sawing Staves.

No. 196,691.

Patented Oct. 30, 1877.

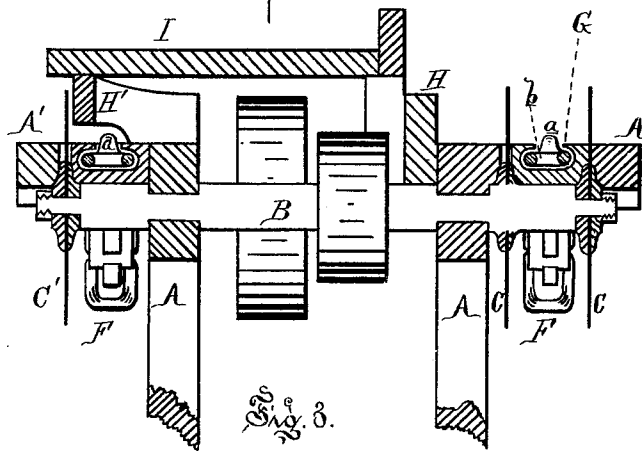
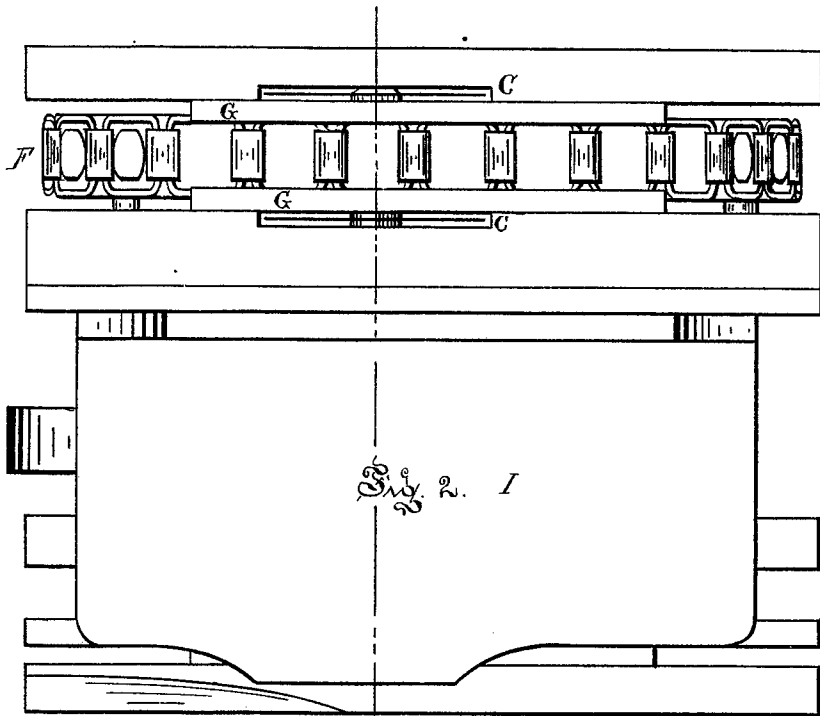

Attest:
H. T. Ames
Charles J. Hunt

Invention:
J. Miller
S. Head
By Atty
Thos. S. Sprague

UNITED STATES PATENT OFFICE.

JAMES MILLER, OF BAY CITY, MICH., AND SMITH HEAD, OF MILLERSBURG, PA.; SAID HEAD ASSIGNOR TO SAID MILLER.

IMPROVEMENT IN MACHINES FOR SAWING STAVES.

Specification forming part of Letters Patent No. **196,691**, dated October 30, 1877; application filed April 4, 1877.

To all whom it may concern:

Be it known that we, JAMES MILLER, of Bay City, in the county of Bay and State of Michigan, and SMITH HEAD, of Millersburg, in the county of Dauphin and State of Pennsylvania, have invented certain new and useful Improvements in Machines for Sawing Staves, of which the following is a specification:

The object we have in view is to combine in the one machine, and mounted on the same arbor, three circular saws, one pair of which will edge slabs into stave-bolts having parallel sides, while the third saw is used to cut the bolts into staves.

The invention consists, first, in the peculiar guides for the carrier-chains, so constructed that if the chain should break or uncouple, the links will be kept away from the saws until the chain is run out of the guides; and, further, in the general combination of the various parts, as more fully hereinafter set forth.

Figure 1 is a perspective view with the table removed. Fig. 2 is a sectional plan. Fig. 3 is a cross-section through the axis of the saw-arbor at *x x*.

In the drawing, A represents the main frame of the machine, in which is transversely journaled an arbor, B, having two circular saws, C C, adjustably mounted thereon at one end, for ripping slabs into bolts, and a single saw, C', at the other end for splitting the bolts into staves or heading, for which purposes there is a saw-table, A', at each side of the machine.

Across each end of the frame is journaled a shaft, D, each carrying a chain-wheel, E, at each end, one shaft having a driving-pulley, D'. Two carrier-chains, F F, are driven by these wheels, one at each saw-table, each chain having at intervals a metal dog, *a*, inserted in one of its links to push forward the timber to and past the saws.

A chain-guide, G, is let into each saw-table, flush with its face, and in it is longitudinally cut a dovetail groove, *b*, through which the wide links of the chain pass, the narrower ones and the studs passing through the top slot.

H is a gage on the inner edge of the bolting-saw table. The slabs thrown onto the said table, being carried along by the spurs of the chain, are ripped into two parallel bolts by the saws C C.

After passing through the saws, the bolts are thrown onto a table, I, on the top of the machine, and thence are taken and laid onto the traveling chain at the other side, which takes each past the single saw, between it and the gage H', cutting off a stave, the operation being repeated until the bolt is sawed up.

The gage H' is elevated above the plane of the saw-table, in order to permit the dogs of the chain, which are bent outward, to engage with the bolt to pass under it.

Should either chain break, or a link uncouple, there is no danger of its getting to the saws, as the dovetail guide keeps the broken chain in place until run out of the guide, when it will drop to the floor.

What we claim as our invention is—

1. The chain-guides G, having a dovetail groove, *b*, for the chain to run in, substantially as described, for the purpose specified.
2. The combination, in a single machine, of two adjustable bolting-saws and a single slitting-saw mounted on the same arbor, with their necessary tables and gages, substantially as and for the purpose described.

JAMES MILLER.
SMITH HEAD.

Witnesses:

H. S. SPRAGUE,
• H. F. EBERTS.