

Dec. 13, 1938.

R. W. MILLER

2,139,692

LUBRICATOR LOCATING DEVICE

Filed Nov. 3, 1936

2 Sheets-Sheet 1

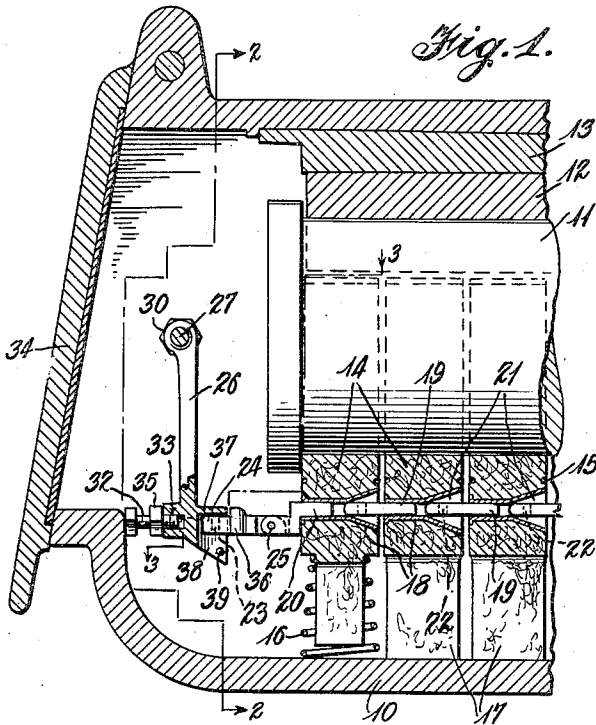

Fig. 1.

Fig. 3.

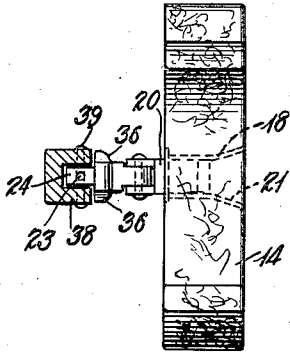
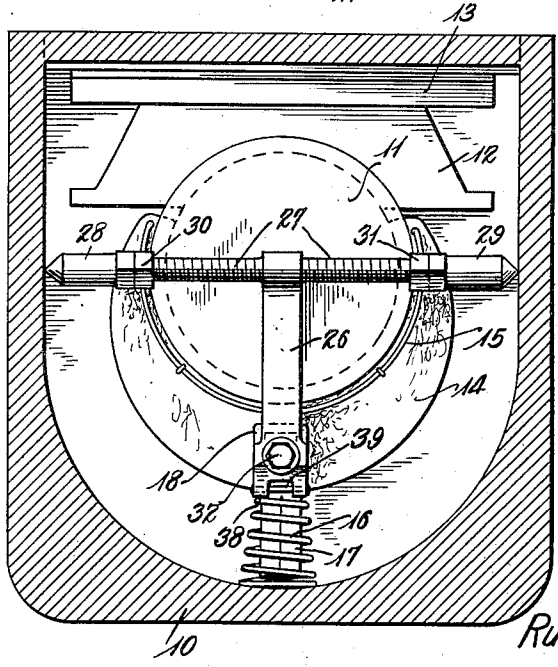

Fig. 2.



Inventor

Rudolph W. Miller

By

Brown & Phelps

Attorneys

Dec. 13, 1938.

R. W. MILLER

2,139,692

LUBRICATOR LOCATING DEVICE

Filed Nov. 3, 1936

2 Sheets-Sheet 2

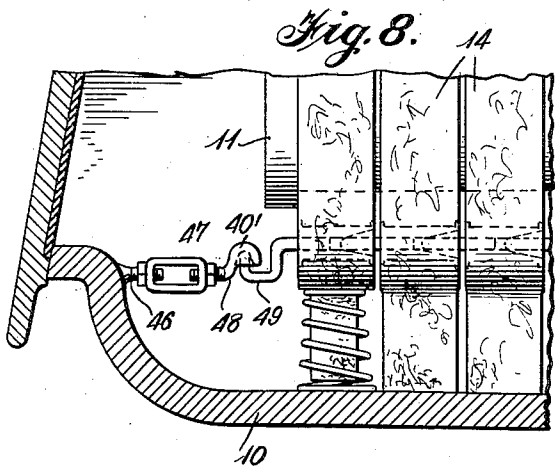
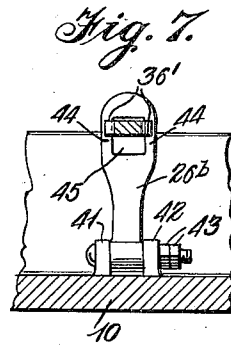
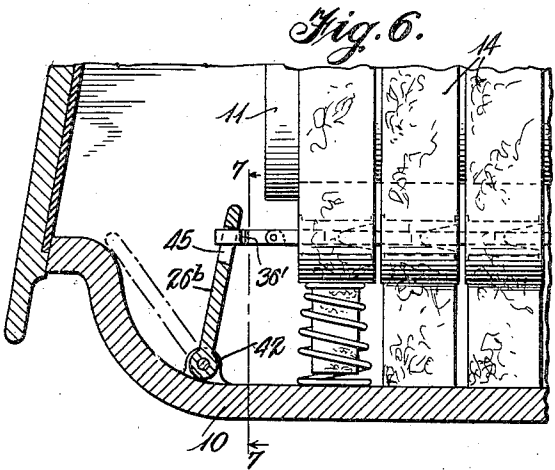
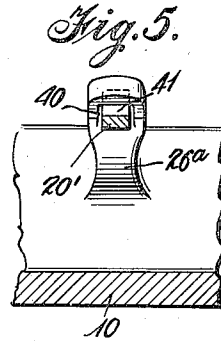
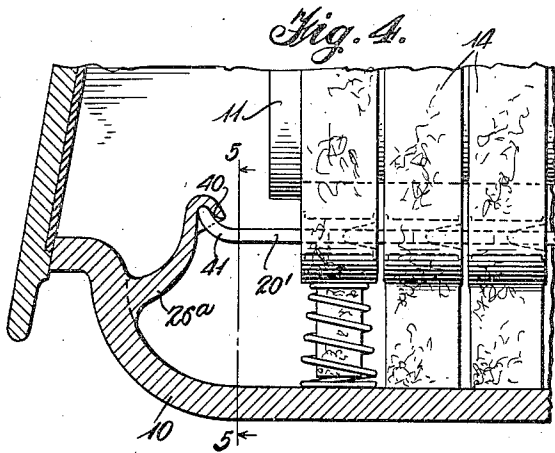

Inventor
Rudolph W. Miller

By *Brown & Phelps*
Attorneys

UNITED STATES PATENT OFFICE

2,139,692

LUBRICATOR LOCATING DEVICE

Rudolph W. Miller, Winona, Minn.

Application November 3, 1936, Serial No. 109,017

13 Claims. (Cl. 308—88)

The invention relates to lubricators for journal boxes and has as an object the provision of means to locate the lubricator centrally of the journal whereby to prevent the lubricator from twisting under influence of the revolution of the journal, and also to prevent the lubricator from moving endwise in the box so as to depart from the journal surface.

It is an object of the invention to provide a device of the character described comprising a bracket which will permit the journal box to be raised relative to the journal for the purpose of removing and renewing the brass without previous removal of the lubricator or bracket from beneath the journal.

It is a further object of the invention to provide a lubricator having a hinged rod to facilitate placing of the lubricator in the journal box, which rod coacts with a bracket to preserve the location of the lubricator after installation.

It is a further object of the invention to provide a lubricator having means for engagement with a tool for removal of the lubricator from the journal box.

Further objects of the invention will appear from the following description when read in connection with the accompanying drawings showing illustrative embodiments of the invention, and wherein:—

Figure 1 is a detail central vertical section of a portion of a lubricator and journal box with one form of the invention in plate;

Fig. 2 is a transverse section on broken line 2—2 of Figure 1;

Fig. 3 is a detail horizontal section on line 3—3 of Figure 1 showing a section of the lubricator in plan;

Fig. 4 is a detail central vertical section of a portion of a journal and box showing a different form of the invention;

Fig. 5 is a detail vertical section on line 5—5 of Figure 4;

Figs. 6 and 8 are views similar to Figure 4 showing still further forms of the invention; and

Fig. 7 is a view similar to Figure 5 on line 7—7 of Figure 6.

As shown in Figures 1—3 the journal box is indicated at 10, a portion of the journal at 11, a brass at 12, a wedge at 13, and sections of the lubricator device are indicated at 14.

As shown the lubricator sections are formed of felt and crescent shaped in side elevation provided with bowed springs 15 to hold the arms of the felt in contact with the journal surface. At least some of the lubricator sections are shown as

supported by means of compression springs 16 contacting with the bottom of the journal box to press the felts against the journal surface. The felt elements 14 are further shown as provided with wick elements 17 to conduct oil to the crescent shaped portions of the lubricator in a well known manner.

The felt elements 14 are shown as formed with hollow metallic sleeves 18, each carrying at the portion toward the front of the journal box rods 19 and 20.

The portion of the sleeves 18 which are rearwardly directed are shown as funnel-formed at 21 for ready engagement with the projecting portions of the rods 19 during the assembly of the device.

The rods 19 are further provided with holes 22 in their projecting ends and the rod 20 is provided with a like hole 23, which holes are for the purpose of engagement by means of a hooked tool when it becomes necessary to remove the lubricator from the box. The rods 19 preserve the relation between the lubricator sections and because of their presence it is not absolutely necessary to provide a spring 16 beneath each of the felt sections 14.

The projecting portion 24 of the rod 20 is shown as pivoted to the lubricator-section-engaging-portion of this rod. This hinged portion is provided for the reason that with the form of bracket shown, a rod of sufficient length to extend beyond the end of the journal is difficult of insertion and for the further reason that will be described.

To prevent twisting of the section of the lubricator in the box under influence of revolution of the journal, there is shown in Figures 1—3 a bracket 26, which is T-shaped in elevation, having its horizontal arms 27 screwthreaded for engagement with socketed ends 28, 29 shown as pointed whereby they may be expanded into rigid engagement with the walls of the journal box. Lock nuts 30, 31 are shown to preserve the relation of the portions 28, 29 upon the arms 27.

To prevent movement of the bracket 26 longitudinally of the journal box, there is shown a bolt 32 engaging a screw-threaded socket 33 carried by the bracket 26, which bolt engages a wall of the journal box below the door 34 thereof. The lock nut 35 is shown to preserve the adjustment of the bolt 32.

Upon the portion 24 of the rod 20 there are shown lugs 36 which impinge against the bracket 26 to prevent endwise movement of the journal,

the collar of the journal not being dependable as a preventive of endwise movement.

The lower end of the bracket 26 is shown as formed with a recess defined by a flange 37 and downwardly projecting flanges 38 between which the end of the portion 24 of rod 20 seats.

When a bearing is found to run warm it is the practice particularly in connection with passenger coaches to jack up the journal box to raise the same clear of the journal, when the wedge 13 and the offending brass 12 are removed and a new brass inserted. This servicing is done without delaying the schedule of the train and the crew is expected to replace a brass within a period of fifteen minutes. In present practice when journal boxes are packed with waste, it is necessary to remove the waste before the box is jacked up for the reason that this waste must be packed very tightly into the box and if not removed the journal would lift with the box thus preventing removal of the wedge.

In the form of lubricator shown the spring 16 will be compressed sufficiently to allow the removal of the wedge, the maximum vertical motion usually required being not in excess of three-fourths of an inch. However if any portion of the bracket 26 which must be rigid with the journal box underlies the end of the journal, such motion would be defeated.

In the bracket of the invention no portion projects below the end of the journal and therefore the bracket itself need not be disturbed. Therefore the lubrication provisions of the journal need receive no attention when the brass is to be changed.

In the event that there should be a journal with an abnormal movement, excessive movement of the bracket 26 relative to the portion 24 of the rod would be permitted by the hinged end thereof and a pin 39 is provided through the ends of the flanges 38 to prevent said hinged end from leaving the recess in the bracket 26.

In the form of the invention of Figures 4 and 5, a bracket 25^a is shown as cast rigidly with or secured rigidly to the journal box 10, the end of which has a recess 40 for reception of an upwardly turned end 41 of the rod 20' projecting from the outer lubricator section. This recess being downwardly open and the end of the bracket 26^a being clear of the end of the journal will permit the lifting movement already described.

In the form of Figures 6 and 7, the bracket 26^b is shown as hingedly mounted between lugs 41, 42 rigidly carried by the base of the journal box and held in adjusted position by means of lock nuts 43. By loosening the lock nuts, the arm 26^b can be swung to the dotted line position for insertion of the lubricator. When fixed in full line position, the lugs 36' by engagement with the portions 44 of the arm at each side of the rod-receiving opening 45 will prevent endwise movement of the lubricator and the said opening 45 being extended downwardly below the rod 36' will permit the lifting movement above described without disturbance of the adjustment of the arm.

In the form of the invention of Figure 8, a threaded stud 46 is formed integral with the wall of the journal box which carries a turnbuckle adjusting means 47, the remaining end of the turnbuckle 48 being provided with a recess 49' engaging an upwardly turned portion 49 of the rod 20'.

It will be seen that the lubricator will be effec-

tually located by means of the bracket of the invention while permitting a free and unhampered change of brasses.

Minor changes may be made in the physical embodiments of the invention within the scope of the appended claims without departing from the spirit thereof.

I claim:

1. A lubricator locating device comprising, in combination: a lubricator comprising a form-retaining element in contact with a journal surface; a rod member projecting from said element to a position beyond the end of the journal; a bracket member held rigid with the journal box; means carried by the bracket member freely engaging the sides of said rod to prevent lateral movement thereof and of said element; means carried by the bracket member freely engaging a portion of the end of the rod member to prevent movement of said element axially of the journal toward its free end; one of said members formed of sections hinged together to permit upward movement of said bracket with the journal box relative to the journal.

2. A lubricator locating device comprising, in combination: a lubricator comprising a form-retaining element in contact with a journal surface; a rod rigid with said element and extending to a position beyond the free end of the journal; a bracket rigid with the journal box and having a downwardly open recess enclosing the free end of said rod; said bracket located in advance of the free end of the journal whereby to permit free vertical movement of the bracket with the box relative to said rod in a brass-removing operation.

3. The combination of claim 2 wherein the end portion of the rod is pivoted to the body thereof on a horizontal axis.

4. A lubricator locating device comprising, in combination: a bracket member adapted to be fixed into rigidity with a journal box; means to adjust a portion of said member axially of the journal in said box in positions outside the free end of the journal; said adjustable portion formed with a recess having an end wall; a pre-formed lubricator element; a member rigid with said element projecting into said recess; means carried by one of said members freely engaging the other thereof to prevent endwise movement of the lubricator toward the free end of the journal whereby to prevent lateral and endwise movement of said element while allowing free limited vertical movement of said bracket relative to said rigid means.

5. A lubricator locating device comprising, in combination: a bracket member having a portion laterally expansible into contact with the side walls of a journal box and a portion expansible into contact with an end wall of the box whereby to hold said member rigid with the box; a portion of said member formed with a downwardly open recess; a pre-formed lubricator element in contact with the surface of a journal in the box; and rigid means projecting from said element into said recess.

6. A lubricator comprising a plurality of pre-formed arcuate sections for radial engagement with a journal in a downwardly closed journal box each having a socket at one face and rigid means projecting from the opposite face to enter the socket in the adjacent element; said rigid means formed with a lubricator removing tool engaging means.

7. A lubricator locating device comprising, in

combination: arcuate lubricator means for engagement with a journal radially thereof; rod means projecting therefrom toward the free end of the journal; bracket means independent of
 5 said rod means rigidly carried by the journal box; said rod and bracket means freely inter-engaging for relative vertical movement while preventing lateral and endwise movement of the lubricator relative to the journal.

10 8. A lubricator locating device comprising, in combination: arcuate lubricator means for engagement with a journal radially thereof; rod means projecting therefrom toward the free end of the journal; the free end of said rod means
 15 projecting upwardly; bracket means rigidly carried by the journal box; said last named means formed with a downwardly open and laterally and upwardly closed recess overlying and enclosing the upwardly directed extremity of said rod
 20 means; whereby to prevent lateral and endwise movement of the lubricator.

9. A journal lubricator comprising in combination: absorptive pad means to contact the surface of the journal comprising a plurality of sections
 25 perpendicular to the axis of the journal; a hollow bushing non-circular in cross section penetrating each of said sections, a rod section conforming substantially with the interior of, secured in, and projecting from certain of said
 30 bushings to extend into the bushing of an adjacent section, to preserve alignment between said adjacent sections.

10. A journal lubricator comprising, in combination: absorptive pad means to contact the
 35 surface of the journal comprising a plurality of sections transverse to the axis of the journal; aligning and twist preventing means carried by certain of said sections comprising means penetrating and secured to the sections, said means
 40 presenting an open socket at one side of its section and a projecting non-circular rod at the

remaining side of the section to enter the socket of the next section.

11. A journal lubricator comprising, in combination: a pad to contact the surface of a journal; resilient means to press said pad against the
 5 journal; a flat bar embedded in the structure of the lubricator and projecting forwardly therefrom; a rigid expansible member engaging the projecting end of said bar to prevent rotative
 10 movement thereof; said last named member to be expanded into contact with opposite inner surfaces of a journal box.

12. A journal lubricator comprising, in combination: a pad to contact the surface of a journal; resilient means to press said pad against the
 15 journal; a flat bar embedded in the structure of the lubricator and projecting forwardly therefrom; a rigid expansible member engaging the projecting end of said bar to prevent rotative
 20 movement thereof; said last named member to be expanded into contact with opposite inner surfaces of a journal box.

13. A journal lubricator comprising, in combination: a plurality of independent sections
 25 formed to conform to the surface of a journal perpendicular to the axis thereof and of less overall width than the width of the journal box; resilient means acting upon said sections substantially in a vertical plane passing through the
 30 axis of the journal to press the sections against the surface of the journal; alignment preserving means constructed and arranged to prevent relative rotation between the sections in planes
 35 perpendicular to the axis of the journal comprising, socket means carried by certain of said sections, and means projecting from the sections adjacent to said certain sections and freely entering
 40 and removable from said sockets.

RUDOLPH W. MILLER.