



(12) **EUROPEAN PATENT APPLICATION**
 published in accordance with Art. 153(4) EPC

(43) Date of publication:
04.02.2009 Bulletin 2009/06

(51) Int Cl.:
B66B 5/02 (2006.01) B66B 7/12 (2006.01)

(21) Application number: **06756593.7**

(86) International application number:
PCT/JP2006/310443

(22) Date of filing: **25.05.2006**

(87) International publication number:
WO 2007/138643 (06.12.2007 Gazette 2007/49)

(84) Designated Contracting States:
AT BE BG CH CY CZ DE DK EE ES FI FR GB GR HU IE IS IT LI LT LU LV MC NL PL PT RO SE SI SK TR
 Designated Extension States:
AL BA HR MK YU

(72) Inventor: **HONDA, Takenobu**
Tokyo 100-8310 (JP)

(74) Representative: **HOFFMANN EITL**
Patent- und Rechtsanwälte
Arabellastrasse 4
81925 München (DE)

(71) Applicant: **Mitsubishi Electric Corporation**
Chiyoda-ku
Tokyo 100-8310 (JP)

(54) **ELEVATOR DEVICE**

(57) In an elevator apparatus, a car is suspended by suspension means to be raised/lowered within a hoist-way. The suspension means has a suspension body including a plurality of steel wires, and a resinous coating

body for coating an outer peripheral portion of the suspension body. A coating abnormality detecting device for detecting damage to the coating body is disposed in close proximity to the suspension means.

FIG. 1

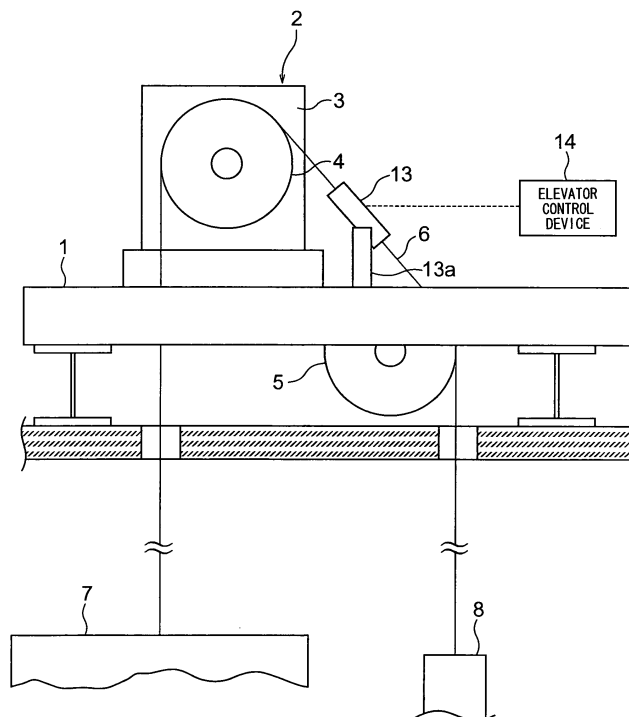

Description

Technical Field

[0001] The present invention relates to an elevator apparatus employing suspension means having a suspension body, which includes a plurality of steel wires, and a resinous coating body for coating an outer peripheral portion of the suspension body.

Background Art

[0002] A conventional magnetic flaw detection apparatus for a rope used for an elevator has a magnetizer for magnetizing the rope, and a detection coil disposed so as to surround the rope to detect a flaw signal. The flaw signal detected by the detection coil is amplified by an amplifier and transmitted to a recorder (e.g., see Patent Document 1).

[0003]

Patent Document 1: JP 54-107037 A

Disclosure of the Invention

Problem to be solved by the Invention

[0004] However, in the case where a resin-coated rope having an outer peripheral portion coated with a resinous coating body is employed, the above-mentioned conventional magnetic flaw detection apparatus cannot detect damage to the coating body such as abrasion or detachment. Besides, a visual inspection is fraught with difficulties in determining how seriously the coating body is damaged.

[0005] The present invention has been made to solve the above-mentioned problem, and it is therefore an object of the present invention to provide an elevator apparatus that makes it possible to detect damage to a coating body with ease.

Means for solving the Problems

[0006] An elevator apparatus according to the present invention includes: a car that is raised/lowered within a hoistway; suspension means having a suspension body including a plurality of steel wires, and a resinous coating body coating an outer peripheral portion of the suspension body, for suspending the car; and a coating abnormality detecting device disposed in close proximity to the suspension means, for detecting damage to the coating body.

Brief Description of the Drawings

[0007]

Fig. 1 is a schematic diagram showing an essential

part of an elevator apparatus according to Embodiment 1 of the present invention.

Fig. 2 is a cross-sectional view of a main rope of Fig. 1.

Fig. 3 is a schematic diagram showing an internal structure of a coating abnormality detecting device of Fig. 1.

Fig. 4 is a schematic diagram showing a coating abnormality detecting device of an elevator apparatus according to Embodiment 2 of the present invention.

Best Modes for carrying out the Invention

[0008] Preferred embodiments of the present invention will be described hereinafter with reference to the drawings.

Embodiment 1

[0009] Fig. 1 is a schematic diagram showing an essential part of an elevator apparatus according to Embodiment 1 of the present invention. Referring to Fig. 1, a machine mount 1 is installed in a machine room in an upper portion of a hoistway. A hoisting machine 2 is installed on the machine mount 1. The hoisting machine 2 has a hoisting machine body 3 including a motor and a brake, and a drive sheave 4 that is rotated by the hoisting machine body 3. The machine mount 1 is provided with a deflector pulley 5 in the vicinity of the hoisting machine 2.

A plurality of main ropes 6 as suspension means are looped around the drive sheave 4 and the deflector pulley 5. A car 7 is suspended at first ends of the main ropes 6. A counterweight 8 is suspended at second ends of the main ropes 6. That is, the car 7 is suspended by the main ropes 6 on one side of the hoisting machine 2, and the counterweight 8 is suspended by the main ropes 6 on the other side of the hoisting machine 2. The car 7 and the counterweight 8 are raised/lowered within the hoistway due to a driving force of the hoisting machine 2.

As shown in Fig. 2, each of the main ropes 6 has a main rope body 11 serving as a suspension body which includes a core strand 9 and a plurality of outer peripheral strands 10 twined around an outer periphery of the core strand 9, and a resinous coating body 12 for coating an outer peripheral portion of the main rope body 11. The core strand 9 is composed of a plurality of twined steel wires. Each of the outer peripheral strands 10 is also composed of a plurality of twined steel wires. The coating body 12 also fills spaces between the core strand 9 and the outer peripheral strands 10, and spaces among the outer peripheral strands 10. The coating body 12 is made of a high-friction resin material with a friction coefficient equal to or larger than 0.2, for example, a polyurethane resin.

A coating abnormality detecting device 13 for detecting damage to the coating body 12 is installed on

the machine mount 1. The coating abnormality detecting device 13 is disposed via a fixture 13a in close proximity to those portions of the main ropes 6 which are located between the drive sheave 4 and the deflector pulley 5. The mounting angle of the coating abnormality detecting device 13 can be adjusted. In addition, the coating abnormality detecting device 13 is connected to an elevator control device 14 for controlling the traveling of the car 7.

[0013] Fig. 3 is a schematic diagram showing an internal structure of the coating abnormality detecting device 13 of Fig. 1. Referring to Fig. 3, a pair of guide pulleys (or rollers) 16a and 16b, which abut on the main ropes 6, are provided within a housing 15. The guide pulleys 16a and 16b are disposed apart from each other in a longitudinal direction of the main ropes 6. A detection portion 17 for detecting damages to the main ropes 6 in a contact-free state is provided between the guide pulleys 16a and 16b within the housing 15. A predetermined gap is secured between each of the main ropes 6 and the detection portion 17 by the guide pulleys 16a and 16b.

[0014] The detection portion 17 has a casing 18, a pair of springs 19a and 19b provided within the casing 18, a magnet 20 fitted between the springs 19a and 19b, a movable-side contact 21 fitted to the magnet 20, and a pair of fixed-side contacts 22a and 22b fixed to the casing 18. The fixed-side contacts 22a and 22b face each other across the movable-side contact 21. A displacement detecting portion for detecting displacement of the magnet 20 has the movable-side contact 21 and the fixed-side contacts 22a and 22b.

[0015] An indicating lamp 23 serving as display means is connected to the detection portion 17. The indicating lamp 23 is lit up when the movable-side contact 21 comes into contact with one of the fixed-side contacts 22a and 22b.

[0016] Next, the operation of the coating abnormality detecting device 13 will be described. When the main ropes 6 are in a normal state, the movable-side contact 21 is open away from the fixed-side contacts 22a and 22b, and the indicating lamp 23 is off. As the coating body 12 is abraded, the suction force acting between the main rope body 11 and the magnet 20 increases, so the magnet 20 is attracted toward each of the main ropes 6 sides. As each of the main ropes 6 is moved, the magnet 20 is also attracted in a moving direction thereof. Then, when the coating body 12 is reduced through abrasion to a predetermined thickness, the movable-side contact 21 comes into contact with one of the fixed-side contacts 22a and 22b.

[0017] Thus, the indicating lamp 23 is lit up, and an abnormality detection signal is transmitted to the elevator control device 14. Upon receiving the abnormality detection signal from the coating abnormality detecting device 13, the elevator control device 14 stops the car 7 immediately as an emergency measure or at a nearest floor, halts the operation of the car 7, and reports the abnormality to an elevator supervising room.

[0018] In the elevator apparatus constructed as de-

scribed above, the main ropes 6 each having the coating body 12 are employed, so a large frictional force acts between the drive sheave 4 and each of the main ropes 6. As a result, a reduction in the weight of the car 7 and a reduction in the size of the hoisting machine 2 can be achieved.

There is an apprehension in that the coating body 12 may be abraded or peeled off due to minor slippage of each of the main ropes 6 with respect to the drive sheave 4. However, the coating abnormality detecting device 13 is disposed in close proximity to each of the main ropes 6, so damage to the coating body 12 can be detected with ease. Consequently, the time and effort required for maintenance and inspection can be lessened.

Further, when the steel wires are broken to protrude outward from the coating body 12, the magnet 20 is mechanically displaced regardless of a magnetic force. Therefore, the coating abnormality detecting device 13 can detect the breaking of the steel wires as well as the abrasion of the coating body 12.

Still further, the coating abnormality detecting device 13 is disposed in close proximity to those portions of the main ropes 6 which are located between the drive sheave 4 and the deflector pulley 5, and is therefore unsusceptible to the influence of the oscillation of each of the main ropes 6. As a result, damage to the coating body 12 can be detected stably.

[0019] In the foregoing example, the combination of the movable-side contact 21 and the fixed-side contacts 22a and 22b is illustrated as a displacement detecting portion. However, the displacement detecting portion is not limited thereto. For example, displacement of the magnet 20 may be monitored with the aid of a proximity sensor or an optical sensor.

Alternatively, displacement of the magnet 20 may be detected in stages with, for example, the use of a slide switch or the arrangement of a plurality of micro switches in a row. Thus, the level of damage to the coating body 12 can be detected, so the operation of the car 7 can be controlled in accordance with the level of the damage to the coating body 12. For instance, it is possible to perform the control of stopping the car 7 immediately as an emergency measure when a high damage level is detected abruptly and stopping the car 7 at a nearest floor when a low damage level is detected.

Embodiment 2

[0020] Reference will be made next to Fig. 4. Fig. 4 is a schematic diagram showing a coating abnormality detecting device of an elevator apparatus according to Embodiment 2 of the present invention. The coating abnormality detecting device 13 of the second embodiment of the present invention has the housing 15, the guide pulleys 16a and 16b, a detection portion 24, and the indicating lamp 23. The detection portion 24 has a casing 25, an eddy current-type coating thickness sensor 26 fitted to the casing 25 and facing the main ropes 6, and a

spring 27 interposed between the casing 25 and the eddy current-type coating thickness sensor 26.

[0021] The eddy current-type coating thickness sensor 26 causes a high-frequency current to flow through a sensor coil within a sensor head to generate a high-frequency magnetic field. Owing to the effect of electromagnetic induction, an eddy current flows through the surfaces of the steel wires residing within the high-frequency magnetic field in a direction perpendicular to the passage of a magnetic flux, so the impedance of the sensor coil changes. The eddy current-type coating thickness sensor 26 detects a distance to each of the steel wires in accordance with a change in oscillation state resulting from the change in impedance, thereby detecting abrasion of the coating body 12. When each of the main ropes 6 comes into contact with the eddy current-type coating thickness sensor 26, the spring 27 is compressed to reduce the pressure of contact of each of the main ropes 6 with the eddy current-type coating thickness sensor 26 equal to or lower than a predetermined value. Embodiment 2 of the present invention is identical to Embodiment 1 of the present invention in other constructional details.

[0022] In the elevator apparatus constructed as described above, the coating abnormality detecting device 13 having the eddy current-type coating thickness sensor 26 is employed, so changes in the thickness of the coating body 12 can be detected continuously. Thus, it is also possible to light up the indicating lamp 23 in different colors or to switch over the method of stopping the car 7 between an emergency stop and a nearest floor stop depending on the thickness of the coating body 12.

[0023] The position of installation of the coating abnormality detecting device 13 is not limited to that of the foregoing examples. The coating abnormality detecting device 13 may be installed at any position on a path of the suspension means as long as the car 7 and the counterweight 8 are not interfered therewith.

The coating abnormality detecting device 13 may be installed either permanently or only in case of necessity (at the time of maintenance and inspection or the like). Further, the display means is not limited to the indicating lamp 23. For example, the display means may be an indicator capable of indicating the level of damage to the coating body 12 or a display for reporting damage to the coating body 12 through the use of characters.

Still further, the display means may be installed apart from the coating abnormality detecting device 13. In addition, two or more display means may be provided, each of which may be installed at a plurality of different positions.

[0024] The cross-sectional construction of the suspension means is not limited to that of Fig. 2, and various types of suspension means can be employed. Moreover, the cross-sectional shape of the suspension means is not limited to that of Fig. 2 either. For example, belt-shaped main ropes may be employed.

Further, although the elevator apparatus illustrated in each of the foregoing examples is designed according

to a 1:1 roping arrangement, namely, such that the car 7 and the counterweight 8 are suspended at both the ends of each of the main ropes 6, the roping arrangement is not limited in particular. For example, the elevator apparatus may be designed according to a 2:1 roping arrangement. In this case, the coating abnormality detecting device 13 can also be mounted on the car 7, for example, in close proximity to the suspension means between a pair of car suspending pulleys.

Still further, although the hoisting machine 2 is installed within the machine room in each of the foregoing examples, the present invention is also applicable to an elevator with no machine room.

Claims

1. An elevator apparatus comprising:
 - a car that is raised/lowered within a hoistway; suspension means having a suspension body including a plurality of steel wires, and a resinous coating body coating an outer peripheral portion of the suspension body, for suspending the car; and
 - a coating abnormality detecting device disposed in close proximity to the suspension means, for detecting damage to the coating body.
2. An elevator apparatus according to Claim 1, wherein the coating abnormality detecting device has a magnet facing the suspension means, and a displacement detecting portion for detecting displacement of the magnet in a longitudinal direction of the suspension means.
3. An elevator apparatus according to Claim 1, wherein the coating abnormality detecting device has an eddy current-type coating thickness sensor for generating an eddy current in each of the steel wires through a high-frequency magnetic field to detect a distance to each of the steel wires in accordance with a change in impedance.
4. An elevator apparatus according to Claim 1, wherein the coating abnormality detecting device has a pair of guide pulleys abutting on the suspension means, and a detection portion disposed between the guide pulleys so that the coating abnormality detecting device faces the coating body to detect the damage to the coating body while remaining out of contact with the suspension means.
5. An elevator apparatus according to Claim 1, wherein the coating abnormality detecting device is provided with display means for displaying detection of the damage to the coating body.

6. An elevator apparatus according to Claim 1, further comprising an elevator control device for controlling traveling of the car, wherein the elevator control device stops the car at a nearest floor when the coating abnormality detecting device 5 detects the damage to the coating body.

10

15

20

25

30

35

40

45

50

55

FIG. 1

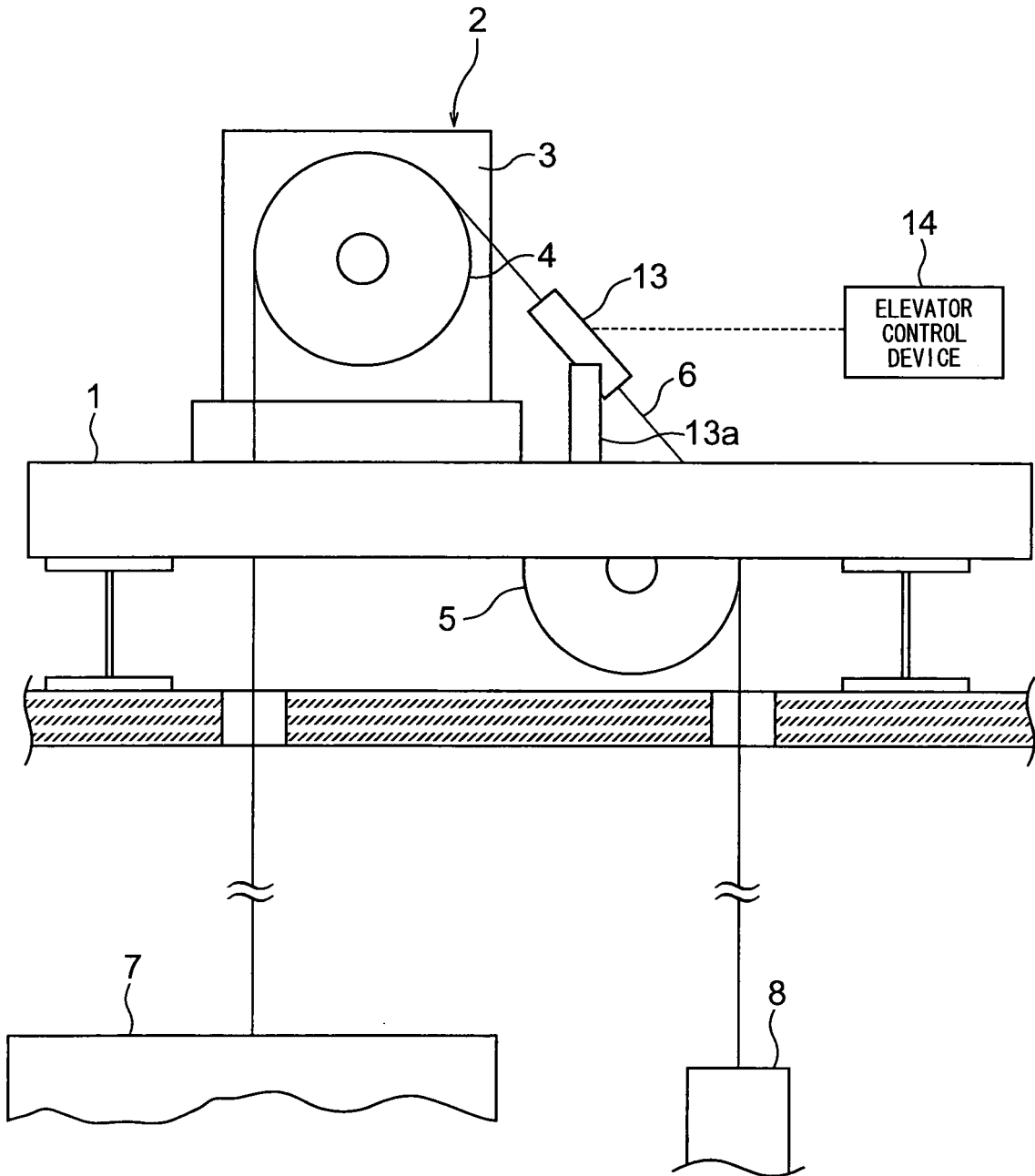

FIG. 2

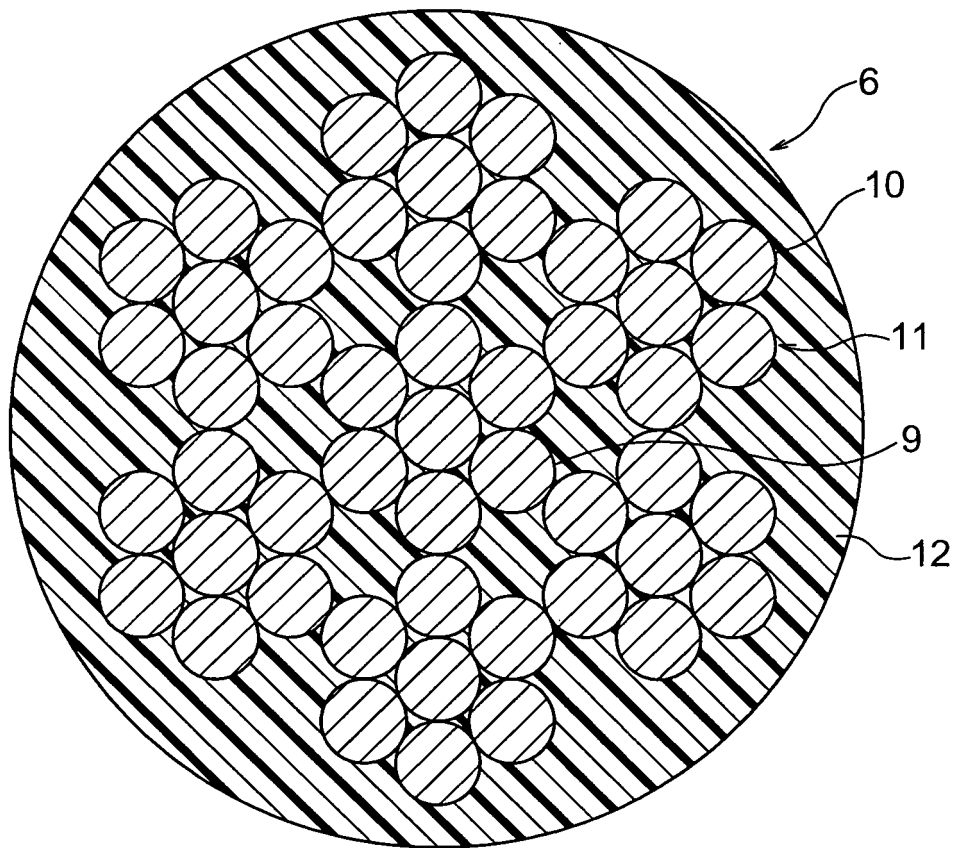
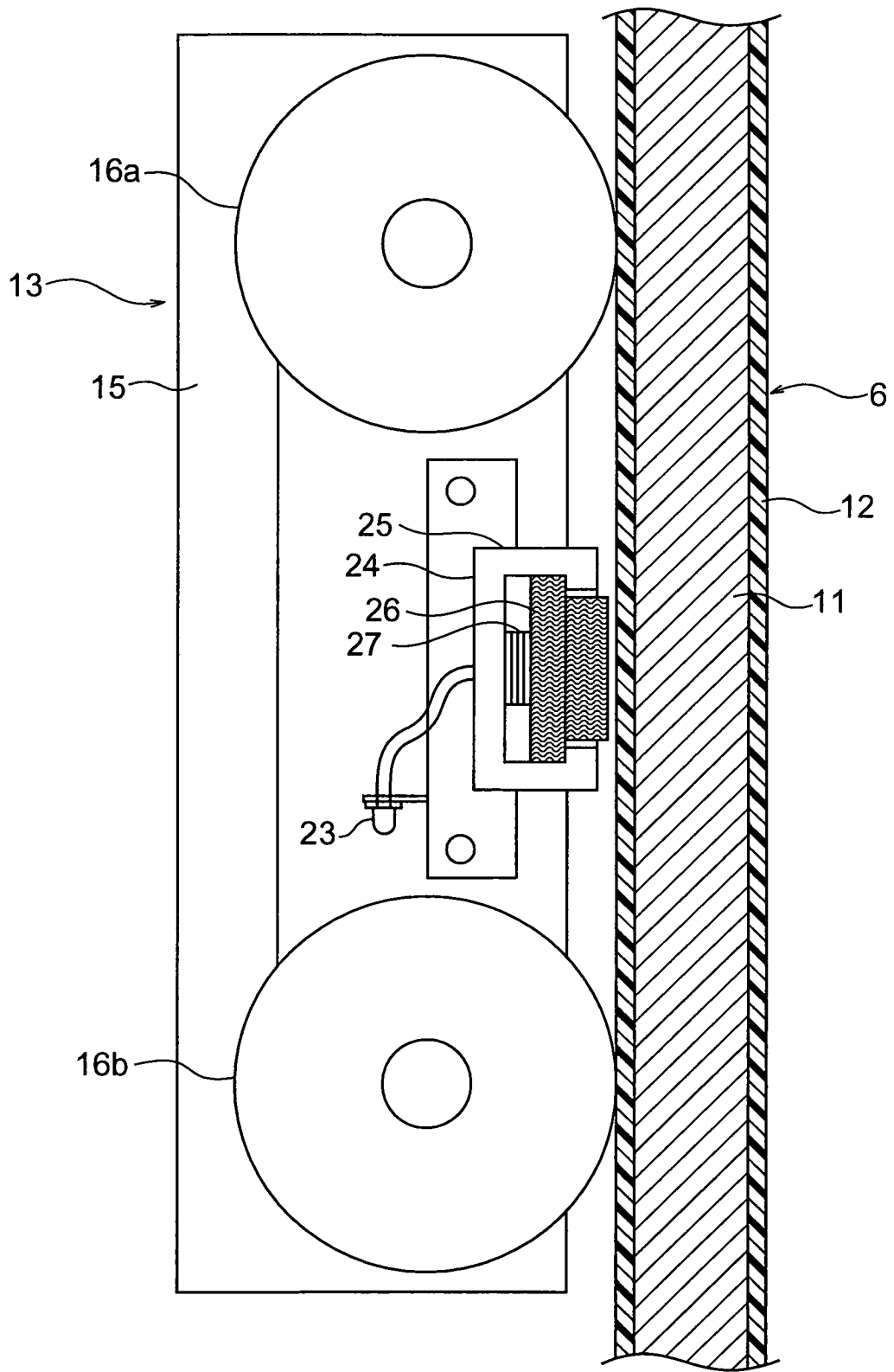

FIG. 4



INTERNATIONAL SEARCH REPORT

International application No.
PCT/JP2006/310443

<p>A. CLASSIFICATION OF SUBJECT MATTER B66B5/02(2006.01) i, B66B7/12(2006.01) i</p> <p>According to International Patent Classification (IPC) or to both national classification and IPC</p>																															
<p>B. FIELDS SEARCHED</p> <p>Minimum documentation searched (classification system followed by classification symbols) B66B5/02, B66B7/12</p> <p>Documentation searched other than minimum documentation to the extent that such documents are included in the fields searched Jitsuyo Shinan Koho 1922-1996 Jitsuyo Shinan Toroku Koho 1996-2007 Kokai Jitsuyo Shinan Koho 1971-2007 Toroku Jitsuyo Shinan Koho 1994-2007</p> <p>Electronic data base consulted during the international search (name of data base and, where practicable, search terms used)</p>																															
<p>C. DOCUMENTS CONSIDERED TO BE RELEVANT</p> <table border="1"> <thead> <tr> <th>Category*</th> <th>Citation of document, with indication, where appropriate, of the relevant passages</th> <th>Relevant to claim No.</th> </tr> </thead> <tbody> <tr> <td>X Y</td> <td>JP 2005-195472 A (Mitsubishi Electric Building Techno-Service Co., Ltd.), 21 July, 2005 (21.07.05), (Family: none)</td> <td>1, 4-5 2-3, 6</td> </tr> <tr> <td>Y</td> <td>CD-ROM of the specification and drawings annexed to the request of Japanese Utility Model Application No. 014516/1993 (Laid-open No. 073072/1994) (Sumitomo Construction Machinery Co., Ltd.), 11 October, 1994 (11.10.94), (Family: none)</td> <td>2</td> </tr> <tr> <td>Y</td> <td>JP 07-218474 A (Hitachi, Ltd.), 18 August, 1995 (18.08.95), (Family: none)</td> <td>3</td> </tr> </tbody> </table> <p><input checked="" type="checkbox"/> Further documents are listed in the continuation of Box C. <input type="checkbox"/> See patent family annex.</p> <table border="1"> <tr> <td>* Special categories of cited documents:</td> <td>"T" later document published after the international filing date or priority date and not in conflict with the application but cited to understand the principle or theory underlying the invention</td> </tr> <tr> <td>"A" document defining the general state of the art which is not considered to be of particular relevance</td> <td>"X" document of particular relevance; the claimed invention cannot be considered novel or cannot be considered to involve an inventive step when the document is taken alone</td> </tr> <tr> <td>"E" earlier application or patent but published on or after the international filing date</td> <td>"Y" document of particular relevance; the claimed invention cannot be considered to involve an inventive step when the document is combined with one or more other such documents, such combination being obvious to a person skilled in the art</td> </tr> <tr> <td>"L" document which may throw doubts on priority claim(s) or which is cited to establish the publication date of another citation or other special reason (as specified)</td> <td>"&" document member of the same patent family</td> </tr> <tr> <td>"O" document referring to an oral disclosure, use, exhibition or other means</td> <td></td> </tr> <tr> <td>"P" document published prior to the international filing date but later than the priority date claimed</td> <td></td> </tr> </table> <table border="1"> <tr> <td>Date of the actual completion of the international search 09 February, 2007 (09.02.07)</td> <td>Date of mailing of the international search report 20 February, 2007 (20.02.07)</td> </tr> <tr> <td>Name and mailing address of the ISA/ Japanese Patent Office</td> <td>Authorized officer</td> </tr> <tr> <td>Facsimile No.</td> <td>Telephone No.</td> </tr> </table>		Category*	Citation of document, with indication, where appropriate, of the relevant passages	Relevant to claim No.	X Y	JP 2005-195472 A (Mitsubishi Electric Building Techno-Service Co., Ltd.), 21 July, 2005 (21.07.05), (Family: none)	1, 4-5 2-3, 6	Y	CD-ROM of the specification and drawings annexed to the request of Japanese Utility Model Application No. 014516/1993 (Laid-open No. 073072/1994) (Sumitomo Construction Machinery Co., Ltd.), 11 October, 1994 (11.10.94), (Family: none)	2	Y	JP 07-218474 A (Hitachi, Ltd.), 18 August, 1995 (18.08.95), (Family: none)	3	* Special categories of cited documents:	"T" later document published after the international filing date or priority date and not in conflict with the application but cited to understand the principle or theory underlying the invention	"A" document defining the general state of the art which is not considered to be of particular relevance	"X" document of particular relevance; the claimed invention cannot be considered novel or cannot be considered to involve an inventive step when the document is taken alone	"E" earlier application or patent but published on or after the international filing date	"Y" document of particular relevance; the claimed invention cannot be considered to involve an inventive step when the document is combined with one or more other such documents, such combination being obvious to a person skilled in the art	"L" document which may throw doubts on priority claim(s) or which is cited to establish the publication date of another citation or other special reason (as specified)	"&" document member of the same patent family	"O" document referring to an oral disclosure, use, exhibition or other means		"P" document published prior to the international filing date but later than the priority date claimed		Date of the actual completion of the international search 09 February, 2007 (09.02.07)	Date of mailing of the international search report 20 February, 2007 (20.02.07)	Name and mailing address of the ISA/ Japanese Patent Office	Authorized officer	Facsimile No.	Telephone No.
Category*	Citation of document, with indication, where appropriate, of the relevant passages	Relevant to claim No.																													
X Y	JP 2005-195472 A (Mitsubishi Electric Building Techno-Service Co., Ltd.), 21 July, 2005 (21.07.05), (Family: none)	1, 4-5 2-3, 6																													
Y	CD-ROM of the specification and drawings annexed to the request of Japanese Utility Model Application No. 014516/1993 (Laid-open No. 073072/1994) (Sumitomo Construction Machinery Co., Ltd.), 11 October, 1994 (11.10.94), (Family: none)	2																													
Y	JP 07-218474 A (Hitachi, Ltd.), 18 August, 1995 (18.08.95), (Family: none)	3																													
* Special categories of cited documents:	"T" later document published after the international filing date or priority date and not in conflict with the application but cited to understand the principle or theory underlying the invention																														
"A" document defining the general state of the art which is not considered to be of particular relevance	"X" document of particular relevance; the claimed invention cannot be considered novel or cannot be considered to involve an inventive step when the document is taken alone																														
"E" earlier application or patent but published on or after the international filing date	"Y" document of particular relevance; the claimed invention cannot be considered to involve an inventive step when the document is combined with one or more other such documents, such combination being obvious to a person skilled in the art																														
"L" document which may throw doubts on priority claim(s) or which is cited to establish the publication date of another citation or other special reason (as specified)	"&" document member of the same patent family																														
"O" document referring to an oral disclosure, use, exhibition or other means																															
"P" document published prior to the international filing date but later than the priority date claimed																															
Date of the actual completion of the international search 09 February, 2007 (09.02.07)	Date of mailing of the international search report 20 February, 2007 (20.02.07)																														
Name and mailing address of the ISA/ Japanese Patent Office	Authorized officer																														
Facsimile No.	Telephone No.																														

INTERNATIONAL SEARCH REPORT

International application No.
PCT/JP2006/310443

C (Continuation). DOCUMENTS CONSIDERED TO BE RELEVANT		
Category*	Citation of document, with indication, where appropriate, of the relevant passages	Relevant to claim No.
Y	JP 2004-232136 A (Mitsubishi Electric Corp.), 19 August, 2004 (19.08.04), (Family: none)	6

Form PCT/ISA/210 (continuation of second sheet) (April 2005)

REFERENCES CITED IN THE DESCRIPTION

This list of references cited by the applicant is for the reader's convenience only. It does not form part of the European patent document. Even though great care has been taken in compiling the references, errors or omissions cannot be excluded and the EPO disclaims all liability in this regard.

Patent documents cited in the description

- JP 54107037 A [0003]