

(19) World Intellectual Property Organization
International Bureau



(43) International Publication Date
11 May 2006 (11.05.2006)

PCT

(10) International Publication Number
WO 2006/048019 A1

- (51) International Patent Classification:
A61F 5/445 (2006.01) A61F 5/441 (2006.01)
- (21) International Application Number:
PCT/DK2005/000703
- (22) International Filing Date:
3 November 2005 (03.11.2005)
- (25) Filing Language: English
- (26) Publication Language: English
- (30) Priority Data:
PA 2004 01689 3 November 2004 (03.11.2004) DK
- (71) Applicant (for all designated States except US): **COLOPLAST A/S** [DK/DK]; Høltedam 1, DK-3050 Humlebæk (DK).
- (72) Inventor; and
- (75) Inventor/Applicant (for US only): **ALBRECHTSEN, Lasse, Skoett** [DK/DK]; Eversvej 1 st. tv., DK-2000 Frederiksberg (DK).
- (74) Common Representative: **COLOPLAST A/S**; Høltedam 1, DK-3050 Humlebæk, Att: Patent Department, Thit Felding (DK).

- (81) Designated States (unless otherwise indicated, for every kind of national protection available): AE, AG, AL, AM, AT, AU, AZ, BA, BB, BG, BR, BW, BY, BZ, CA, CH, CN, CO, CR, CU, CZ, DE, DK, DM, DZ, EC, EE, EG, ES, FI, GB, GD, GE, GH, GM, HR, HU, ID, IL, IN, IS, JP, KE, KG, KM, KN, KP, KR, KZ, LC, LK, LR, LS, LT, LU, LV, LY, MA, MD, MG, MK, MN, MW, MX, MZ, NA, NG, NI, NO, NZ, OM, PG, PH, PL, PT, RO, RU, SC, SD, SE, SG, SK, SL, SM, SY, TJ, TM, TN, TR, TT, TZ, UA, UG, US, UZ, VC, VN, YU, ZA, ZM, ZW.
- (84) Designated States (unless otherwise indicated, for every kind of regional protection available): ARIPO (BW, GH, GM, KE, LS, MW, MZ, NA, SD, SL, SZ, TZ, UG, ZM, ZW), Eurasian (AM, AZ, BY, KG, KZ, MD, RU, TJ, TM), European (AT, BE, BG, CH, CY, CZ, DE, DK, EE, ES, FI, FR, GB, GR, HU, IE, IS, IT, LT, LU, LV, MC, NL, PL, PT, RO, SE, SI, SK, TR), OAPI (BF, BJ, CF, CG, CI, CM, GA, GN, GQ, GW, ML, MR, NE, SN, TD, TG).

Published:
— with international search report

For two-letter codes and other abbreviations, refer to the "Guidance Notes on Codes and Abbreviations" appearing at the beginning of each regular issue of the PCT Gazette.

(54) Title: A CLEANABLE FILTER FOR AN OSTOMY APPLIANCE

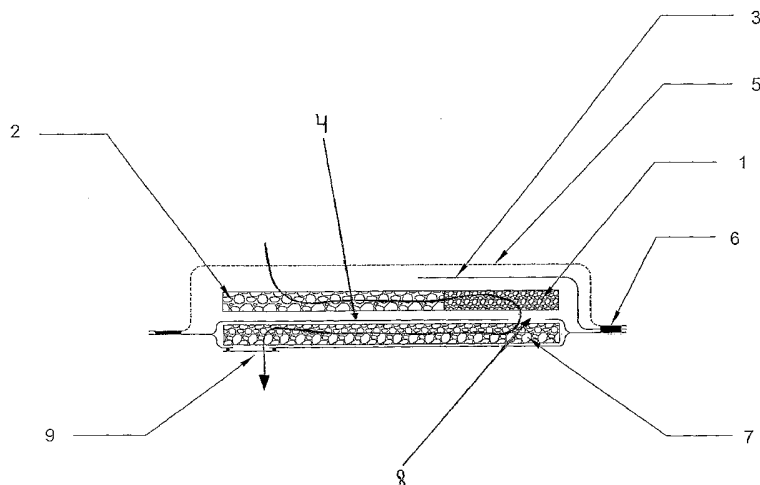

(57) Abstract: The present invention relates to an *in situ* cleanable filter for an ostomy appliance comprising a pathway for leading gases to a vent in an ostomy bag and a protective element contained in said pathway to prevent solid or semi-liquid waste from blocking the pathway where a channel or compartment formed by liquid impermeable layer(s) (3, 4) is defining at least part of the pathway and at least a part of said compartment or channel contain a protective element (1, 2) of an open celled compressible material having a memory and having a pore size of at least 60 PPI, said protective element extending in the same direction as the gas flow within the channel or compartment, said channel or compartment having an opening providing access to the pathway from the interior of the bag, said pathway having another opening (8) being connected to a vent (9) in the ostomy bag, optionally via a deodorizing filter (7). The invention relates to an ostomy appliance comprising a filter as above and a method for emptying and cleaning the filter.

WO 2006/048019 A1

TITLE

A Cleanable Filter for an ostomy Appliance

The present invention relates to an ostomy appliance with a filter which may be
5 cleaned during use, to an ostomy appliance comprising such a filter as well as to
a method for cleaning of the filter.

Background

The invention relates to ostomy appliances for receiving bodily waste from
colostomy or ileostomy patients and in particular to the filters used in connection
10 with ostomy bags for removal of malodour of flatus collected in the bag, before
the gases are released to the environment.

A number of publications describes such filters and the problem with solid or
semi-liquid waste blocking the filter and causing malfunctioning of the filter.
15 Methods for protecting such filters from liquid and solid bodily waste are also
described. Such methods include covering the inlet opening of the filter with a
porous protection film and with a foam.

Thus, EP 607 028 discloses an ostomy bag for holding body waste comprising a
20 bag formed from a flexible plastic sheet material defining a waste collection
chamber. The bag defines a gas outlet proximate a top end portion of the bag. A
deodorising filter is joined to the bag in alignment with the gas outlet means for
deodorizing gaseous waste material before the gaseous waste exits from the bag
through the gas outlet. In the bag, there is provided means for protecting the
25 deodorizing filter from contact with semi-liquid waste material, and for permitting
the flow of gaseous waste, and for obstructing the flow of semi-liquid waste, the
protection means comprises a porous protection film preceding the deodorizing
filter and further comprising an open cell foam material preceding the porous
protection film so that the gaseous waste has to pass through the open cell foam
30 material, and thereafter through the porous protection film before it passes

through the filter. It is thereby sought to provide a multi stage filter system that prevents semi-liquid waste material from contaminating the deodorizing element.

5 US 6,135, 976 discloses an ostomy appliance comprising a front wall and a rear wall of a flexible material. One of the walls has one or more vents through which gas may escape from the bag. The patent discloses a filter covering the vent, which filter comprises an elongated substantially flat filter body of a porous filter material interposed between gas and liquid permeable walls which are sealed to the filter body along its longitudinal edges. Gas inlet and outlet openings are
10 provided in communication with the filter material in adjacent ends of the longitudinal filter. The gas and liquid impermeable walls are sealed to the upper and lower surfaces of the filter body. In use, gas flows longitudinally through the filter from the inlet opening to the outlet opening. The inlet opening is covered with a micro porous hydrophobic and oleophobic membrane, and a foam material
15 is placed so that it precedes said membrane but also covers the inlet opening of the vent.

These filters have improved resistance to wetting and blocking of the deodorizing filter. However, even if improved, it has been found that such filters may
20 eventually become blocked due to faeces being deposited therein, which is inconvenient and unpleasant for the patient.

The filters according to the present invention comprises a protective element in the form of an open celled compressible material having a memory and having a
25 very small pore size, suitably the pore size is above 60 PPI (pores per inch).

It has been found that by the use of the protective element according to the invention, the membrane or the porous or perforated film covering the inlet opening of the deodorizing filters described above has become superfluous.

30

Moreover, it has been found that filters having protective elements extending in the direction of the gas flow and having a very small pore size may be cleaned *in situ*.

- 5 The filters described in the above publications generally describe the use of protective foam elements covered by foils allowing access of gases through a few small openings in the foil which prevents solid or semi-liquid bodily waste from entering the protective foam element. Thus, once bodily waste get into these protective foams and block for the passage of gases, they are difficult to clean
10 due to the limited access to the protective foam elements.

The filters according to the invention are characterised by having a relatively large opening in the channel or compartment containing the protective element, the relatively large opening enabling *in situ* cleaning of the protective element by
15 squeezing solid or semi-liquid waste out and away from the protective element.

None of the above-mentioned publications describes or suggest *in situ* cleaning of the filters for ostomy appliances.

Summary

- 20 The present invention relates to a filter for an ostomy appliance comprising a pathway for leading gases to a vent in an ostomy bag and a protective element contained in said pathway to prevent solid or semi-liquid waste from blocking the pathway where a channel or compartment formed by liquid impermeable layer(s) is defining at least part of the pathway and at least a part of said compartment or
25 channel contain a protective element of an open celled compressible material having a memory and having a pore size of at least 60 PPI, said protective element extending in the same direction as the gas flow within the channel or compartment, said channel or compartment having an opening providing access to the pathway from the interior of the bag, and said pathway having another
30 opening being connected to a vent in the ostomy bag, optionally via a deodorizing filter.

- In another embodiment, the invention relates to a filter for an ostomy appliance comprising a pathway for leading gases to a vent in an ostomy bag and containing a protective element in said pathway to prevent solid or semi-liquid waste from blocking said pathway where a channel or compartment formed by liquid impermeable layer(s) is defining at least part of the pathway and at least a part of said compartment or channel contain a protective element of an open celled compressible material having a memory, said protective element extending in the same direction as the gas flow within the channel or compartment, said channel or compartment having an opening providing access to the pathway from the interior of the bag and said pathway having another opening directly connected to the inlet opening of a deodorizing filter, so that gases which have passed the protective element are lead directly into the deodorizing filter.
- 15 In a final aspect, the invention relates to an ostomy appliance comprising a filter as above and a method for emptying or cleaning the filter.

Detailed Disclosure

Fig. 1 shows a filter according to the invention having a flat, longitudinally extending shape and the same filter in combination with a deodorizing filter to form a layered structure.

Fig. 2 shows a sectional view of a filter according to the invention having a flat, essentially circular or ring formed shape and the combination thereof with a deodorizing filter to form a layered structure.

Fig. 3a shows a bottom view of the filter of Fig. 2.

Fig. 3b shows a top view of the filter of Fig. 2.

Fig. 4 shows a very simple, low cost filter according to the invention and the combination thereof with a deodorizing filter to form a layered structure.

Figs. 5, 6 and 7 show various embodiments of a filter according to the invention.

Fig. 8a shows a top view of another embodiment of a filter according to the invention.

5

Fig. 8b shows a sectional view of the filter of Fig. 8a.

Fig. 9 shows the position of a filter of the invention within an ostomy bag.

10 During use of ostomy bags with filters protected by various foam elements or porous membranes, the filters may become blocked by solid or semi-liquid waste entering the foam material and/or coming into contact with a membrane placed to protect the gas inlet opening of the deodorizing filter. The known filters described above are designed to minimize access to the protecting elements within the
15 pathway and thereby reduce the risk of these elements becoming blocked. The narrow passages, on the other hand, complicate the removal of waste material once it has entered into the protective element and is blocking the filter.

The present invention relates to a filter for an ostomy appliance which may be
20 cleaned *in situ* during use.

According to the invention, filters which may be emptied and cleaned *in situ* are provided by creating a pathway for gaseous waste which is open in one end and connected to the gas inlet opening of the deodorising filter body and/or a vent in
25 an ostomy bag, in the other end. The pathway is filled with a protective element extending in the direction of the gas flow within the pathway. Suitably, the protective element is a foam, enclosed between liquid impermeable layers forming a channel or compartment defining at least part of said pathway. The compartment, channel and pathway have at least one opening in either end and
30 may have many forms or shapes. Preferably, the compartment, channel and pathway have an opening in either end.

The pathway for gases is defined by gas impermeable, or gas and liquid impermeable layers.

5 The material used for the protective element according to the invention is an open celled compressible material with a memory having a particularly small pore size.

10 By open celled compressible material with a memory is meant a material having pores and/or cavities which are connected to each other allowing passage, at least of gases, and which may be compressed, suitably to the extent that the pores and cavities disappear, but the material essentially resumes its original structure with pores and/or cavities once the pressure is removed from the material (the material has a memory).

15 Such open celled compressible material with a memory may be selected from various foam materials, woven and non-woven material of fibres, such as polymer fibres, or metal fibres, a material consisting of numerous elastic bodies, suitable having spherical shape, of a material which may be compressed and has a memory.

20 According to a preferred embodiment of the invention, the open celled compressible material with a memory is a foam. Suitable foams may be selected from polystyrene, polyvinylchloride, polyethylene, polyurethane, polyphenol, polyester and silicone. or polyisocyanate foam, such as polyester- or polyether based polyurethane foam.

25 The use of a material having a low pore size within the pathway provides an effective stopper ensuring the blockade of the pathway does not become permanent.

30 According to a preferred embodiment of the invention, the material used for the protective element is a material having a pore size of at least 80 PPI, suitably a

pore size between 60 and 200 PPI, more preferred a pore size between 60 and 150 PPI and most preferred a pore size between 80 and 100 PPI.

5 PPI means pores per inch and is measured by counting the number of walls between pores, which is passed per inch, when passing linearly over a surface of the material.

10 The protective element having the small pore size may have a uniform pore size throughout the element. Alternatively, the protective element has a gradually decreasing pore size going from one end of the element to the other end of the element within the pathway, the pore size decreasing in the same direction as the intended direction for the gases to be passing through the pathway.

15 The protective element may be preceded in the pathway by additional protective element(s), in particular protective elements having a larger pore size. The additional protective element(s) are suitably placed in continuation of, and in direct contact with the protective element with the small pore size, so that the gases and other waste material passes the element with the largest pore size before it passes the protective element with the small pore size.

20 The additional protective element(s) also consist of an open celled compressible material having a memory and have a PPI below 60.

25 Suitable, the additional protective elements having the larger pore size has a pore size between 20 and 60 PPI (pores per inch), suitably PPI is around 40.

30 Each additional protective element may have a uniform pore size or it has a gradually decreasing pore size going from the one end of the additional protective element(s) to the other end, the pore size decreasing in the same direction as the direction of the gas flow.

According to one embodiment of the invention, the protective element and the additional protective element(s) are made from one single piece of open celled compressible material, for example a material having a gradually decreasing pore size, where the part having a pore size above 80 is the protective element having the small pore size and the part having a PPI below 80 being the "additional protective element". In another embodiment, the protective element consist of two or more pieces of an open celled compressible material with a memory, being placed in continuation of each other and pressed, welded, glued or in any other way held together within the pathway.

10

A protective element with a gradually decreasing pore size may be achieved by squeezing the protective element within the pathway, for example by using the same volume of protective element in the whole length of the channel or compartment, but constructing the channel or compartment containing the protective element so that it becomes narrower in the direction of the gas flow. Alternatively, a larger volume of protective element is used in one end of the channel or compartment compared to the other end.

15

An alternative way of achieving material with different pore sizes would be to coat or fill the protective element or a part of a protective element with a material reducing the pore size, or alternatively enlarging or creating holes in a material or a part of a material. According to these embodiment(s) of the invention, the protective element and any additional protective element(s) may be in the form of one single unit which have been treated to obtain an element with a pore size above 80 PPI in one end and a pore size below 80 PPI in the other end.

20

25

The protective element and the additional protective element(s) need not be made from the same type of material. Thus, one of the elements may be a foam and the other element may be a fiber material. Suitably however, both types of protective elements are of a foam material.

30

The term "shortest pathway" within the channel or compartment means the shortest pathway through the part of the channel or compartment which is filled with the protective element, in a "hypothetical" situation where the protective element is not present in the compartment or channel.

5

According to the invention, the part of the channel or compartment, which is filled with the protective element, defines a shortest pathway which extends longitudinally within the channel or compartment in the same direction as the gas flow. Preferably, the protective element extends longitudinally within a channel.

10

The dimensions of the protective element and thereby also the channel or compartment formed by the liquid impermeable layers is suitably such that the shortest pathway through the protective element is as least as long, preferably more than 50 % longer, or most preferred more than 100 % longer than the most narrow cross-section perpendicular to the shortest pathway defined above.

15

It is important that the protective element and additional protective element(s) fits tightly with the walls of the channel or compartment in order to prevent solid or semi-liquid waste from bypassing the protective elements. This may be achieved by the use of a protective element(s) with a volume which fit into the channel or compartment formed by the liquid impermeable layers, or is a little larger. The protective element(s) may be attached to the liquid impermeable layers forming the channel or compartment by gluing, lamination, welding or by any other suitable methods.

20

Faeces blocking the foam element may be removed from the foam element by providing a pressure, for example a manual pressure using the fingers, on the part of the gaseous pathway defined by the liquid impervious layers and containing the protective element(s) and squeezing or pushing the solid or semi-liquid waste blocking the protective element out and away from the gaseous pathway formed by the liquid impermeable layers, suitably, but not necessarily in the direction opposite the direction of the gas flow. Once faeces have been

25

30

removed from the protective element(s), the protective element(s) essentially, or at least partly, resumes its original volume and pore structure allowing gases to pass through the protective element. According to the invention, the ostomy patient may clean the filter easily and as often as necessary.

5

By "in situ cleaning" is meant that the filter can be cleaned without removing any parts or elements of the filter from its location. The cleaning is typically done by simply adding pressure to relevant filter parts or elements, e.g. the protective element.

10

In one embodiment of the invention the protective element may be displaced in relation to the deodorising element so that the area which the user has to press in order to clean the filter is correspondingly displaced. This displacement provides the advantage of being able to place the area, which the user has to press in order to clean the filter, in a position which is particularly advantageous, e.g. for accommodating ease of use and/or accessibility for the user. The relative placement of the protective element and the deodorising element can be done in numerous ways which will be appreciated by the skilled person.

15

20 It is important that the opening in the channel or compartment accommodating the protective element is sufficiently large to allow particle and semi-liquids which have entered the element to be removed from the protective element by squeezing the element in the direction of the opening providing access to the pathway from the interior of the ostomy bag.

25

In order to achieve efficient removal of material blocking the protective element(s), the area of the opening in the channel or compartment providing access to pathway from the interior of the ostomy bag preferably corresponds to the cross-sectional area of the protective element, in its essentially
30 uncompressed form, in the end closest to said opening in the channel or compartment.

In one particular embodiment of the invention a part of the protective element and/or additional protective element(s) is sticking out of said opening providing access to the pathway from the interior of the ostomy bag.

- 5 According to one embodiment of the invention at least the opening providing access to the pathway from the interior of the ostomy bag is covered by a perforated foil.

10 The perforated foil or a woven or non-woven material, suitably based on polyethylene, polyvinylchloride, polypropylene, PVDC, EVA (ethylene-vinyl acetate), polyester or other polymeric materials.

The pore size in the perforated foil may be between 3 μ m and 2 mm, suitably between 10 μ m and 500 μ m in diameter.

15

Due to the numerous pores in the perforated foil or the non-woven material, solid or semi-liquid waste which have crossed the barrier represented by the perforated foil or non-woven material and entered the protective element(s), may easily be removed.

20

The liquid impermeable layers and the gas and liquid impermeable layers used according to the invention are suitably made from foils of polyethylene, EVA or other suitable polymeric materials.

- 25 The liquid impermeable layers and the gas and liquid impermeable layers are suitably of a kind that may be welded together.

Various ways of constructing a filter according to the invention may be considered.

30

According to one particular embodiment of the invention, the protective element(s) consists of two oblong pieces of foam having different pore size, being

placed in continuation of each other. According to this embodiment of the invention, the foam element is an essentially flat foam layer wherein the two pieces of foam taken together are at least double as long as they are broad and at least as broad as they are thick. Typically, the dimensions of the oblong foam elements having two zones with different pore size is 10-80 mm long, 3-20 mm broad and 1-5 mm thick. Preferably, the dimensions of the oblong foam elements having two zones with different pore size are 3 mm x 8 mm x 40 mm.

According to this embodiment of the invention, the oblong pieces of foam are contained in a channel formed by liquid impermeable layers having an opening in either end of the channel. The opening in the end of the channel closest to the foam element with the smallest pore size may at the same time be the inlet opening to a deodorizing filter or a vent. The deodorizing filter may be placed in continuation of the protective foam elements or it may be placed as a layer below or above the foam element. These different embodiments are illustrated in Fig. 1.

According to this embodiment, the protective element(s) between liquid impermeable layers and the deodorising filter consist of an essentially flat structure, however, the protective element(s) and/or the deodorizing filter could also have the form of a rod in a channel formed by liquid impermeable layers.

According to another more simple embodiment of the invention, the foam element consists of a single oblong foam element having a small pore size, suitably above 60 PPI, which is at least as long as it is broad, and as least as broad as it is high. The foam element is laminated between two liquid impermeable layers, creating a channel having an opening in both ends. The channel may be laminated or welded on top of a deodorizing filter or placed in continuation of a deodorizing filter. This embodiment of the invention is illustrated in Fig. 4.

Of course each oblong protective element need not be a foam element but may be a protective element made from any other open celled compressible material with a memory having the appropriate pore size.

According to another embodiment of the invention, the protective element(s) have the form of two or more essentially flat, concentric rings of protective material having the protective element with the smallest pore size placed closest to the hole in the centre of the circle formed by the rings. According to this embodiment, the circular protective element(s) with or without a hole in the middle have at least a part of the one of its surfaces covered by a liquid impermeable layer, suitable a circular liquid impermeable layer, and the opposite surface of the protective element is covered with a liquid impermeable layer having essentially the same shape and having a hole. These liquid impermeable layers form a compartment in which gases are lead between the to liquid impermeable layers, through the concentric rings of protective element(s) and through the hole in the liquid impermeable layer and thereafter to a deodorizing filter or a vent in the ostomy bag. Fig. 2 illustrates this embodiment of the invention having a deodorizing filter with a flat ring formed structure welded to the pathway containing the protective element(s), thereby forming a flat compact structure.

The flat structure according to this embodiment of the invention, where gases are lead to a hole in the middle of an flat protective element, need not have a circular shape but could have any other convenient shape, such as ellipsoid, rectangular, etc.

The form and shape of the pathway leading the gases from the hole in the middle of the flat structure to the deodorising filter or vent is not particularly important as long as it defines a pathway for the gases. Fig. 2 shows one way of creating a pathway for the gases to a deodorizing filter.

The deodorizing filter used according to the present invention may be any suitable deodorizing filter known in the art. Suitable the deodorising agent is active carbon impregnated onto an open cell foam. These active filters are suitably formed as oblong flat elements being 20-60 mm long, 5-10 mm broad and 2-5 mm high, or as circular discs having a diameter of 20-40 mm and being

2-5 mm thick. In one embodiment, the deodorizing filter has an elongated structure fitting the contours of the upper portion of the ostomy bag.

5 According to one embodiment of the invention, the pathway with the protective element(s) enclosed within liquid impermeable layer(s) and the deodorizing filter form a layered structure comprising the deodorizing filter in the form of one layer and the protective element(s) enclosed within liquid impermeable layer(s) as a second layer and optionally a perforated foil as a third layer, all of the layers, optionally being sealed to each other along the periphery of the layers.

10 According to this embodiment of the invention, all layers suitably have the same area and shape.

The invention also relates to an ostomy appliance comprising a filter as described above.

15

In order to prevent ballooning during cleaning of the filters of the invention, the filters should be placed close to an edge of the ostomy appliance, preferably welded to an edge and/or the walls of the ostomy bag, suitably in the upper part of the ostomy bag.

20

According to this embodiment of the invention, the filter is positioned within the ostomy bag and is welded to the peripheral edge of the bag and/or the wall(s) of the bag, suitable in the upper part of the bag.

25 Suitably, the filter is welded to both walls of the ostomy bag, or placed or welded into a pocket or channel formed by welding both walls of the ostomy bag to each other in a position close to the edge of the ostomy bag.

30 Alternatively, the filter may be placed in a pocket created at the edge of the ostomy bag. Fig. 9 illustrates this embodiment of the invention.

According to the invention, the gas outlet or vent of the ostomy bag may be covered by a perforated film or membrane.

Figures

Fig. 1 shows an essentially flat, oblong filter according to a preferred embodiment of the invention. The filter comprises two oblong pieces of foam (1,2) placed in continuation of each other. The foam element (1) has a small pore size, and the foam element (2) has a large pore size. The foams are placed in a channel formed by the two liquid impermeable layers (3,4), and the liquid and gas impermeable layer (4) has a gas inlet opening (8) into the porous material (7) containing a deodorizing agent (e.g. active carbon). The welding of the liquid impermeable layers is made so that the foils (3,4) fit closely to the two pieces of foam, allowing no by-pass of liquid waste in the channel. Preferably, the foam element is glued or welded to the side walls of the channel formed by the liquid impermeable layers (3,4). A part of the foam element having the largest pore size (2) is extending out of the channel. In this figure, the foam and the liquid impermeable layer (3) is covered by a perforated foil (5) which is sealed (6) to the gas and liquid impermeable layers. In this figure, the outlet opening (9) is covered by a membrane, e.g. a perforated foil.

Fig. 2 shows an alternative embodiment of the invention wherein the filter is a circular essentially flat construction. The filter comprises two concentric foam layers with different pore size (1,2) fitted into a channel formed by liquid impermeable layers (3, 4a) creating a pathway for gases which goes through foam element (2) having a large pore size and thereafter through foam element (1) having a small pore size and via the hole in the middle of the foam element to the gas inlet opening of a deodorizing filter welded (6) on top of the deodorizing filter, which is also circular and has the same centre as the foam layer. The perforated layer (5) is sealed to a liquid impermeable layer layers (4a), suitably by welding along the periphery. In this figure the outlet opening (9) is covered by a membrane, e.g. a perforated foil.

Fig. 3a shows a bottom view of the filter of Fig. 2 showing the position of the deodorising element (7) and the outlet opening (9).

5 Fig. 3b shows a top view of the filter of Fig. 2 showing the position of the two concentric foam layers with different pore size (1,2), the liquid impermeable layer (3), and a welded (6) area.

10 Fig. 4 shows yet another embodiment of the invention where an oblong foam element (1) having a small pore size which is preferably at least twice as long as it is broad and is at least as broad as it is high. The foam element is placed or laminated between two liquid impermeable foils forming a channel with an opening in both ends, one end having connection to the interior of e.g. an ostomy bag and the other end being in connected to the filter body via the inlet opening of the deodorizing filter (7). The channel fits tightly around the foam. In this figure
15 the outlet opening (9) is covered by a membrane, e.g. a perforated foil. The filter is welded to a wall (10) of the ostomy bag.

20 Figs. 5, 6 and 7 show other filters according to the invention, showing the position of foam having a small pore size (1), foam having a large pore size (2) and a deodorizing element (7).

25 Figs. 8a and 8b show an embodiment of the invention where the foam element (1) is displaced in relation to the deodorising element (7) so that the foam element (1) is placed relatively closer to one end of the oblong deodorising element (7) than the other.

30 Fig. 9 shows the position of the filter according to the invention at an upper edge in an ostomy bag. In the figure an oblong and curved filter (1) according to the invention has been welded into a pocket formed by welding (10) the filter to both walls of the ostomy bag and to the edge of the ostomy bag (10). In this figure, the outlet opening (9) is covered by a membrane, e.g. a perforated foil.

Claims

1. A filter for an ostomy appliance comprising a pathway for leading gases to a vent in an ostomy bag and a protective element contained in said pathway to prevent solid or semi-liquid waste from blocking the pathway **characterized in**
- 5 **that** a channel or compartment formed by liquid impermeable layer(s) is defining at least part of the pathway and at least a part of said compartment or channel contain a protective element of an open celled compressible material having a memory and having a pore size of at least 60 PPI, said protective element extending in the same direction as the gas flow within the channel or
- 10 compartment, said channel or compartment having an opening providing access to the pathway from the interior of the bag, and said pathway having another opening being connected to a vent in the ostomy bag, optionally via a deodorizing filter.
- 15 2. A filter for an ostomy appliance comprising a pathway for leading gases to a vent in an ostomy bag and containing a protective element in said pathway to prevent solid or semi-liquid waste from blocking said pathway **characterized in**
- that** a channel or compartment formed by liquid impermeable layer(s) is defining at least part of the pathway and at least a part of said compartment or channel
- 20 contain a protective element of an open celled compressible material having a memory, said protective element extending in the same direction as the gas flow within the channel or compartment, said channel or compartment having an opening providing access to the pathway from the interior of the bag and said pathway having an another opening directly connected to the inlet opening of a
- 25 deodorizing filter, so that gases which have passed the protective element are lead directly into the deodorizing filter.
3. The filter according to claim 2 wherein the open celled compressible material has a pore size of at least 60 PPI.

4. The filter according to any of claims 1-3 wherein the part of the channel or compartment containing the protective element defines a shortest pathway through the protective element and said shortest pathway is as least as long, preferably more than 50 % longer, or most preferred more than 100 % longer than the most narrow cross-section of the protective element perpendicular to said shortest pathway.
- 5
5. The filter according to any of claims 1-4 wherein the protective element is extending longitudinally within a channel formed by liquid impermeable layers.
- 10
6. The filter according to any of claims 1-5 wherein the protective element has a uniform pore size throughout the protective element.
7. The filter according to any of claims 1-5 wherein the protective element has a gradually decreasing pore size, the pore size decreasing in the direction towards the vent(s) within the pathway.
- 15
8. The filter according to any of claims 1-8 wherein said protective element is preceded in said pathway by one or more additional protective element(s) of an open celled compressible material having a memory and having a PPI below 60.
- 20
9. The filter according to claim 8 wherein the additional protective element(s) has a uniform pore size.
- 25
10. The filter according to claim 8 wherein the additional protective element(s) has a gradually decreasing pore size, the pore size decreasing in the direction of the vent(s) within the pathway.
- 30
11. The filter according to any of claims 8-9 wherein the protective element and the additional protective element(s) lie in continuation and in contact with each other or the protective element and the additional protective element(s) form a single unit.

12. The filter according to any of claims 1-11 wherein the area of the opening in said channel or compartment providing access to pathway from the interior of the ostomy bag corresponds to the cross-sectional area of the protective element in the end closest to said opening in the channel or compartment.

13. The filter according to claim 12 where a part of the protective element and/or additional protective element(s) is sticking out of said opening providing access to the pathway from the interior of the ostomy bag.

14. The filter according to any of claims 1-13 wherein at least the opening providing access to the pathway from the interior of the ostomy bag is covered by a perforated foil or a non-woven material.

15. The filter according to any of claims 1-14 wherein the protective element is a foam, suitably a foam selected from polyester- or polyether based polyurethane.

16. The filter according to any of claims 2-15 wherein the filter has a layered structure comprising the deodorizing filter in the form of one layer, the protective element enclosed within liquid impermeable layer(s) as a second layer on top of the deodorizing filter and optionally a perforated foil as a third layer, all of the layers, being sealed to each other along the periphery of the layers.

17. The filter according to any of claims 2-15 wherein the protective element(s) enclosed within liquid impermeable layer(s) and the deodorizing filter is placed in continuation of each other in an longitudinally extending structure.

18. An ostomy appliance comprising a filter according to any of claims 1-17 directly or indirectly connected to a vent of the ostomy bag.

30

19. The ostomy appliance according to claim 18 wherein the filter is positioned within the ostomy bag and is welded to the peripheral edge of the bag and/or the wall(s) of the bag, suitable in the upper part of the bag.
- 5 20. The ostomy appliance according to claim 19 wherein the filter is welded to both walls of the ostomy bag, or placed or welded into a pocket or channel formed by welding both walls of the ostomy bag to each other in a position close to the edge of the ostomy bag.
- 10 21. A method for cleaning a filter according to any of claims 1-20 comprising providing a pressure on the part of the pathway defined by the liquid impermeable layers containing the protective element(s) and squeezing or pushing solid or semi-liquid waste contained in the protective element(s) or in the vicinity of the protective element(s) out and away from the channel or
- 15 compartment containing the protective element, suitably in the direction opposite the gas flow.

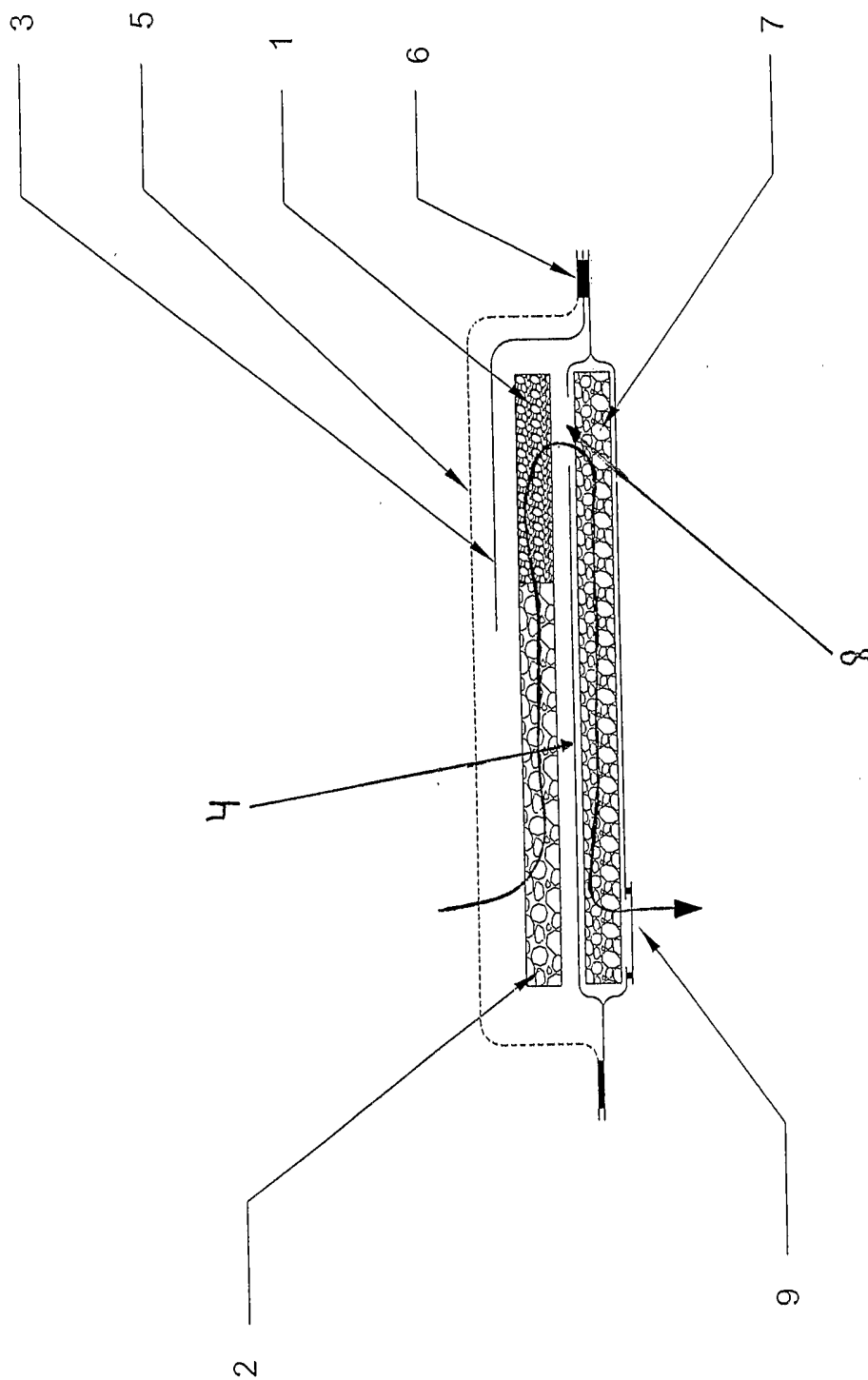

Fig. 1

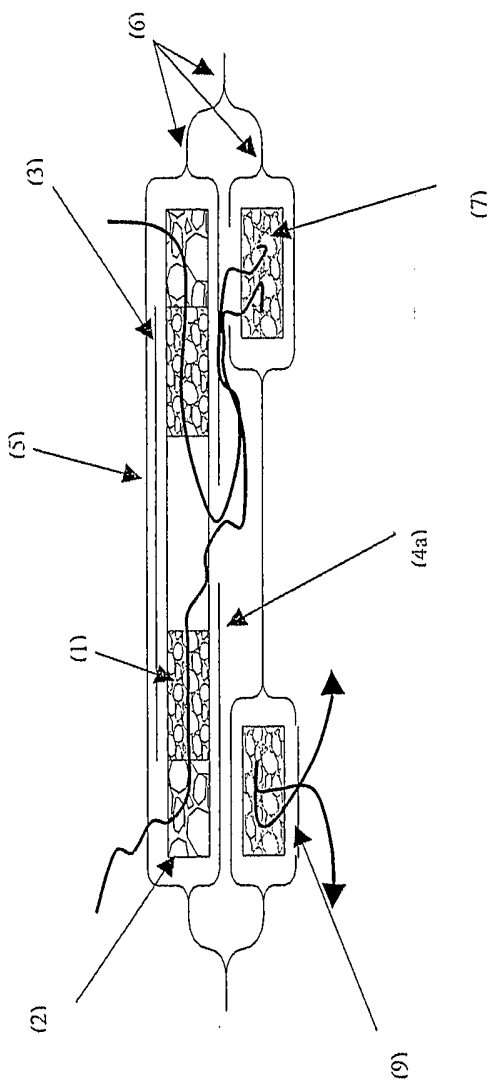

Fig. 2

3/9

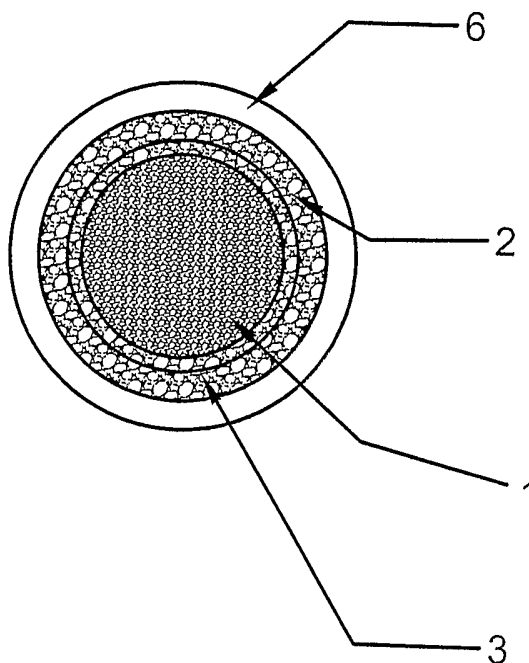

Fig. 3b

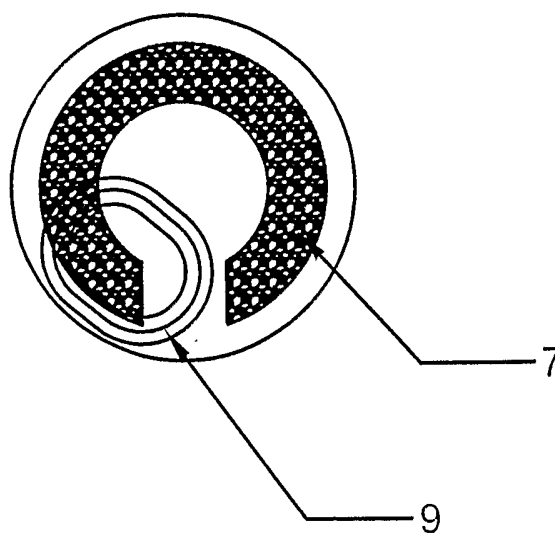

Fig. 3a

4/9

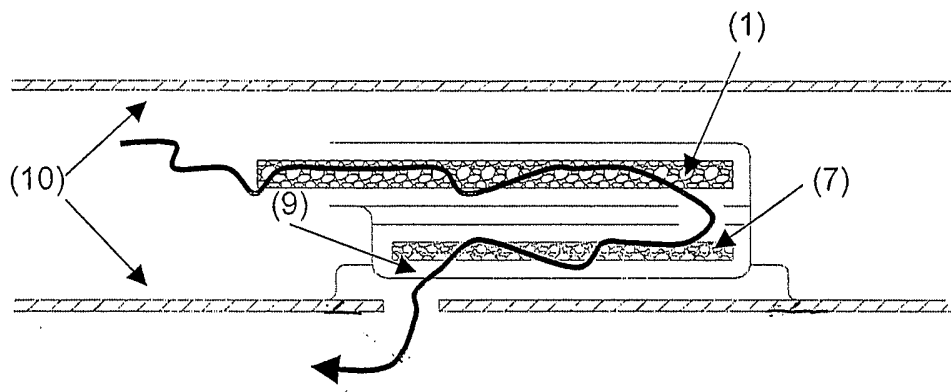

Fig. 4

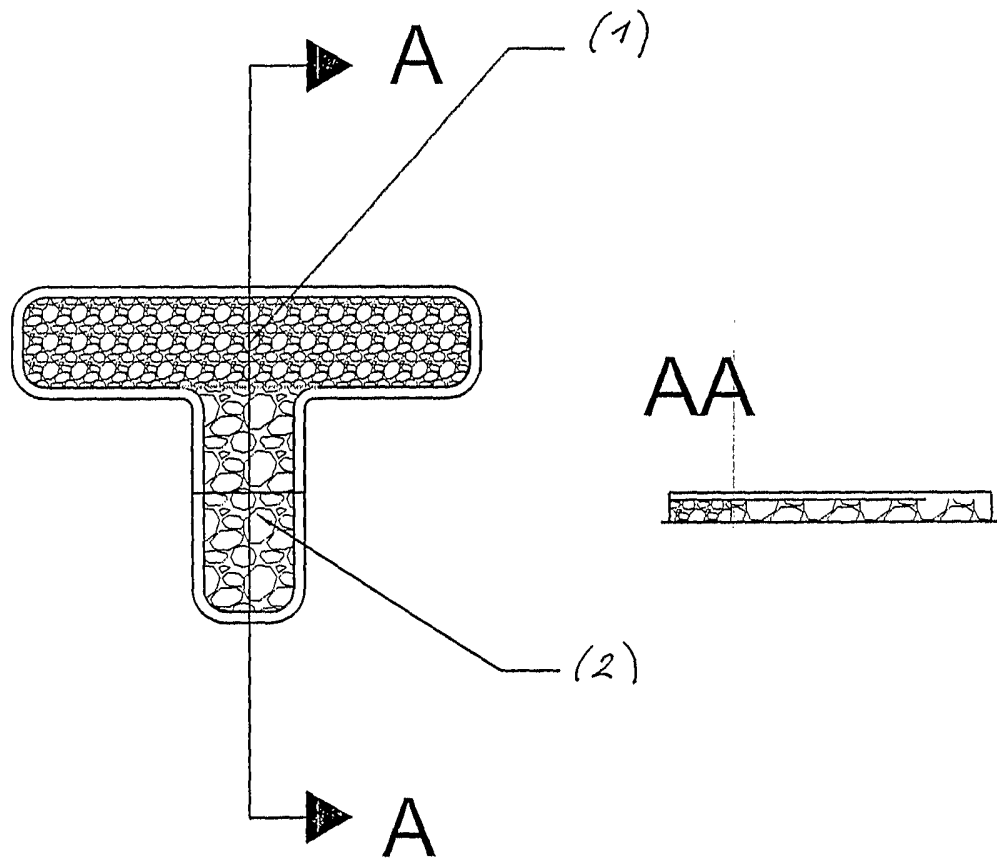

Fig. 5

6/9

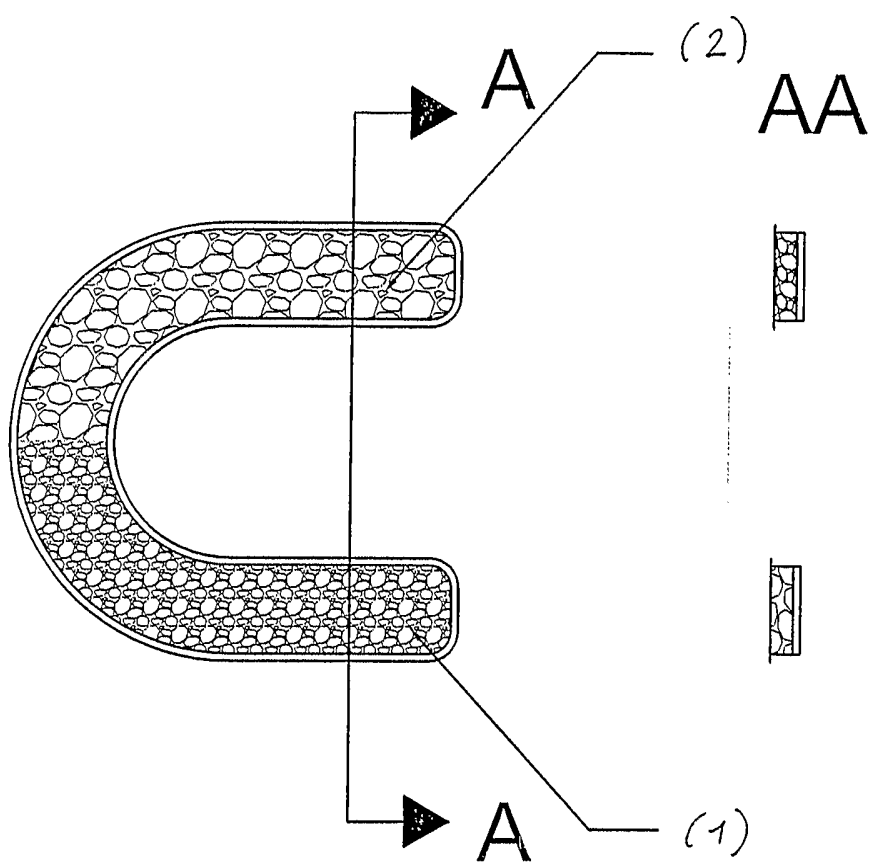

Fig. 6

7/9

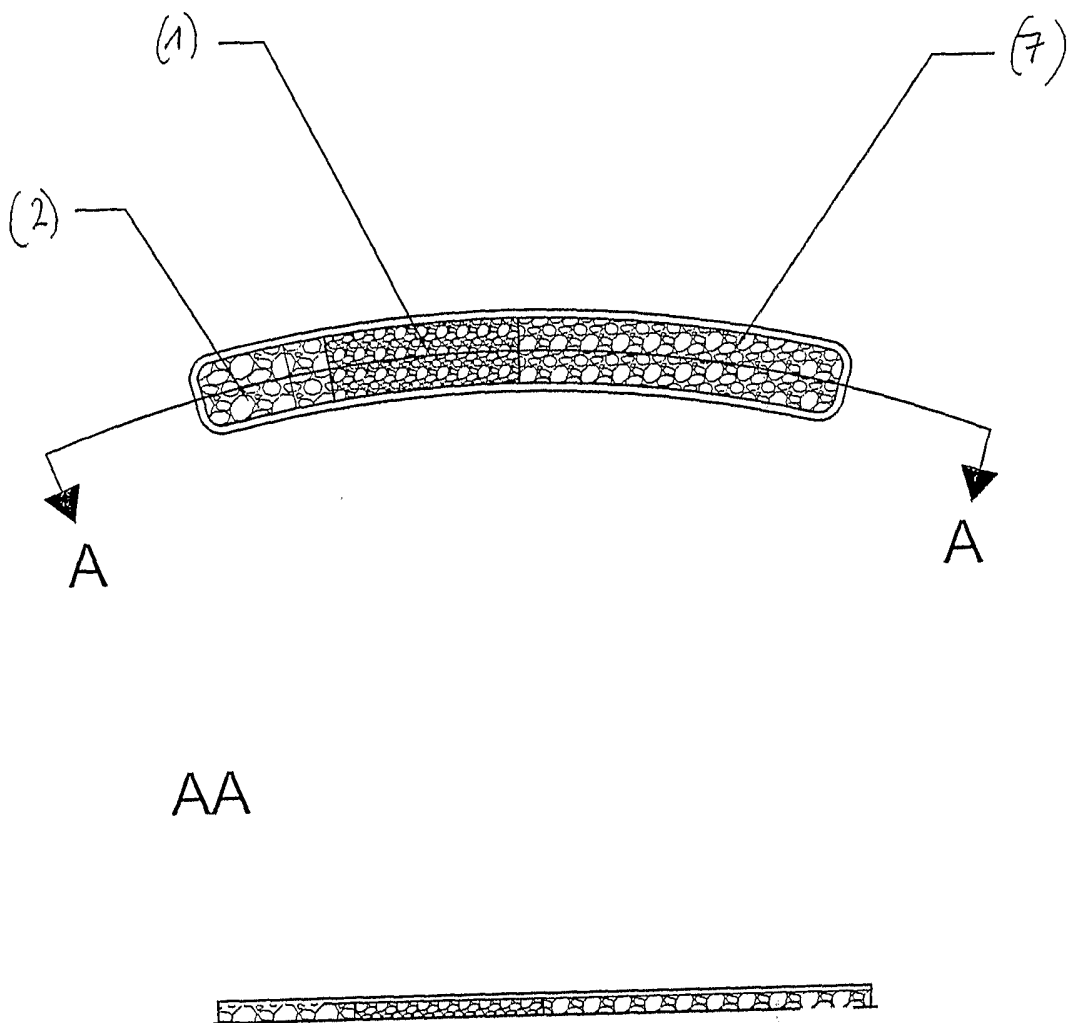

Fig. 7

8/9

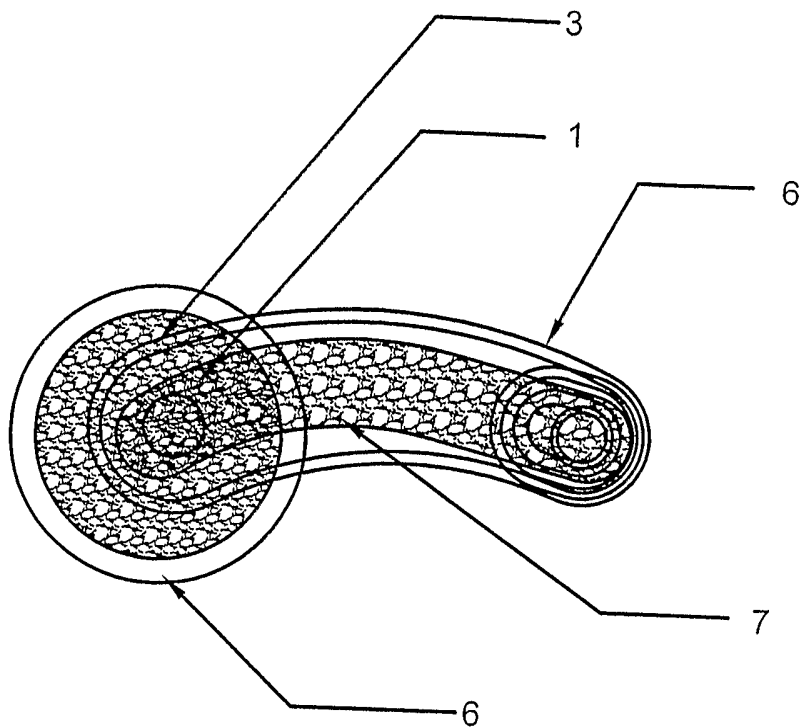

Fig. 8a

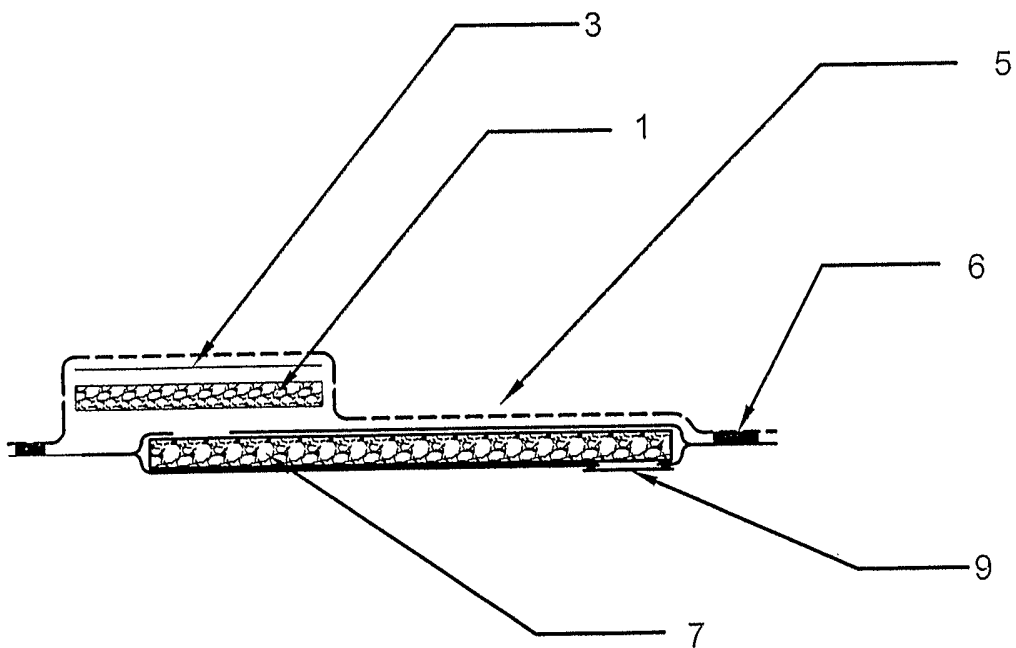

Fig. 8b

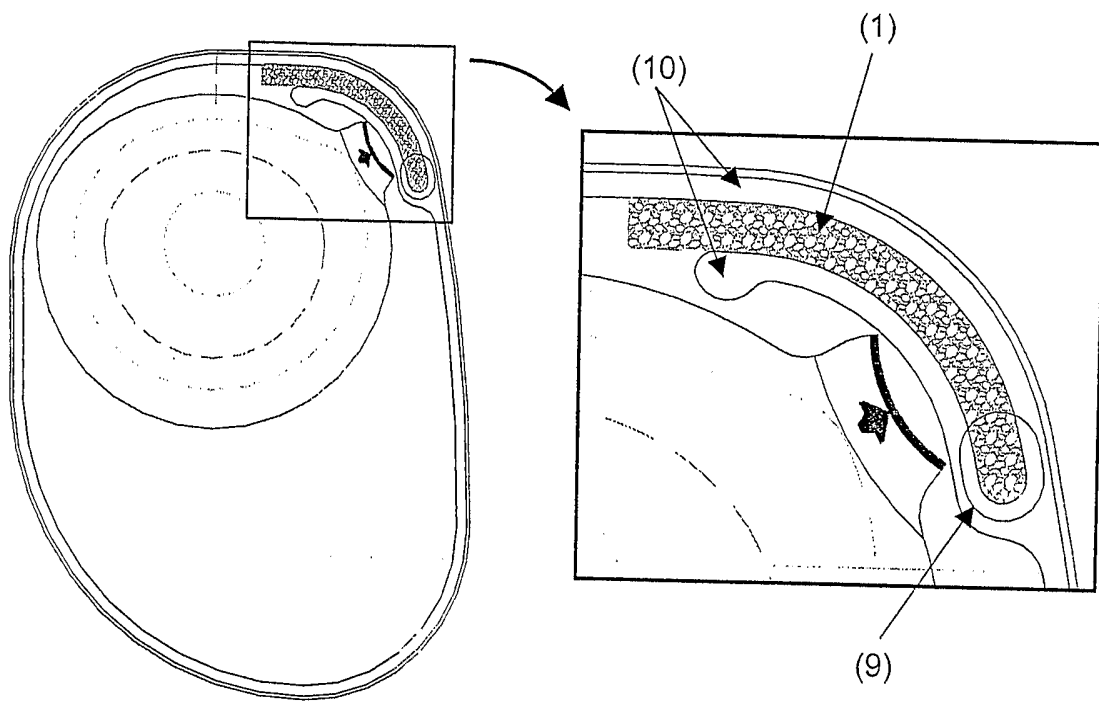

Fig. 9

INTERNATIONAL SEARCH REPORT

International Application No
PCT/DK2005/000703

A. CLASSIFICATION OF SUBJECT MATTER
A61F5/445 A61F5/441

According to International Patent Classification (IPC) or to both national classification and IPC

B. FIELDS SEARCHED
Minimum documentation searched (classification system followed by classification symbols)
A61F

Documentation searched other than minimum documentation to the extent that such documents are included in the fields searched

Electronic data base consulted during the international search (name of data base and, where practical, search terms used)
EP0-Internal

C. DOCUMENTS CONSIDERED TO BE RELEVANT

Category °	Citation of document, with indication, where appropriate, of the relevant passages	Relevant to claim No.
X	US 4 668 258 A (STEER ET AL) 26 May 1987 (1987-05-26) column 2, line 50 - column 3, line 13 column 3, line 52 - column 4, line 9 table A	1,5,6, 15,18
Y	figures	3
X	US 6 135 986 A (LEISNER ET AL) 24 October 2000 (2000-10-24) cited in the application abstract column 9, line 46 - line 51 column 12, line 18 - line 59 claim 8	2,4,5, 14-16,18
Y	figures 10,11	3
	----- -/--	

Further documents are listed in the continuation of box C. Patent family members are listed in annex.

° Special categories of cited documents :

<p>"A" document defining the general state of the art which is not considered to be of particular relevance</p> <p>"E" earlier document but published on or after the international filing date</p> <p>"L" document which may throw doubts on priority claim(s) or which is cited to establish the publication date of another citation or other special reason (as specified)</p> <p>"O" document referring to an oral disclosure, use, exhibition or other means</p> <p>"P" document published prior to the international filing date but later than the priority date claimed</p>	<p>"T" later document published after the international filing date or priority date and not in conflict with the application but cited to understand the principle or theory underlying the invention</p> <p>"X" document of particular relevance; the claimed invention cannot be considered novel or cannot be considered to involve an inventive step when the document is taken alone</p> <p>"Y" document of particular relevance; the claimed invention cannot be considered to involve an inventive step when the document is combined with one or more other such documents, such combination being obvious to a person skilled in the art.</p> <p>"&" document member of the same patent family</p>
--	--

Date of the actual completion of the international search 20 December 2005	Date of mailing of the international search report 29/12/2005
--	---

Name and mailing address of the ISA European Patent Office, P.B. 5818 Patentlaan 2 NL - 2280 HV Rijswijk Tel. (+31-70) 340-2040, Tx. 31 651 epo nl, Fax: (+31-70) 340-3016	Authorized officer Storer, J
--	--

INTERNATIONAL SEARCH REPORT

International Application No
PCT/DK2005/000703

C.(Continuation) DOCUMENTS CONSIDERED TO BE RELEVANT		
Category °	Citation of document, with indication, where appropriate, of the relevant passages	Relevant to claim No.
X	EP 0 607 028 A (E.R. SQUIBB & SONS, INC) 20 July 1994 (1994-07-20) cited in the application abstract column 4, line 2 - column 5, line 1 column 5, line 25 - line 38 column 6, line 8 - column 7, line 10 column 7, line 52 - column 8, line 3 figures 3-6,9,10 <p style="text-align: center;">-----</p>	2,4-6,8, 9,11-20
A	US 4 490 145 A (CAMPBELL ET AL) 25 December 1984 (1984-12-25) abstract <p style="text-align: center;">-----</p>	1
A	US 4 367 742 A (ORNSTEIN ET AL) 11 January 1983 (1983-01-11) abstract figures <p style="text-align: center;">-----</p>	1

INTERNATIONAL SEARCH REPORT

Information on patent family members

International Application No
PCT/DK2005/000703

Patent document cited in search report	A	Publication date	Patent family member(s)	Publication date
US 4668258	A	26-05-1987	GB 2171052 A ZA 8600486 A	20-08-1986 24-09-1986
US 6135986	A	24-10-2000	AT 272991 T AU 742004 B2 AU 6918798 A BR 9809081 A CA 2286217 A1 CN 1251980 A DE 69825585 D1 DE 69825585 T2 WO 9844880 A1 EP 0981311 A1 ES 2224372 T3 JP 2001519696 T NO 994883 A	15-08-2004 13-12-2001 30-10-1998 01-08-2000 15-10-1998 03-05-2000 16-09-2004 11-08-2005 15-10-1998 01-03-2000 01-03-2005 23-10-2001 08-12-1999
EP 0607028	A	20-07-1994	AT 226807 T AU 673557 B2 AU 5314994 A CA 2113131 A1 DE 69431608 D1 DE 69431608 T2 DK 607028 T3 ES 2185642 T3 JP 3590084 B2 JP 6277245 A US 5306264 A ZA 9400165 A	15-11-2002 14-11-1996 21-07-1994 15-07-1994 05-12-2002 26-06-2003 24-02-2003 01-05-2003 17-11-2004 04-10-1994 26-04-1994 11-07-1994
US 4490145	A	25-12-1984	AU 571537 B2 AU 2946284 A CA 1233383 A1 DE 3483027 D1 DK 311184 A EP 0130019 A2 ES 8605973 A1 IE 56290 B1 IL 72164 A JP 6002484 A NO 842585 A NZ 208565 A ZA 8404602 A	21-04-1988 03-01-1985 01-03-1988 27-09-1990 28-12-1984 02-01-1985 01-10-1986 05-06-1991 31-07-1988 07-02-1985 28-12-1984 27-11-1987 25-09-1985
US 4367742	A	11-01-1983	NONE	